

510-520 = 12.22
 521-528 = 13.22
 529-535 = 14.10
 536-546 = 15.47

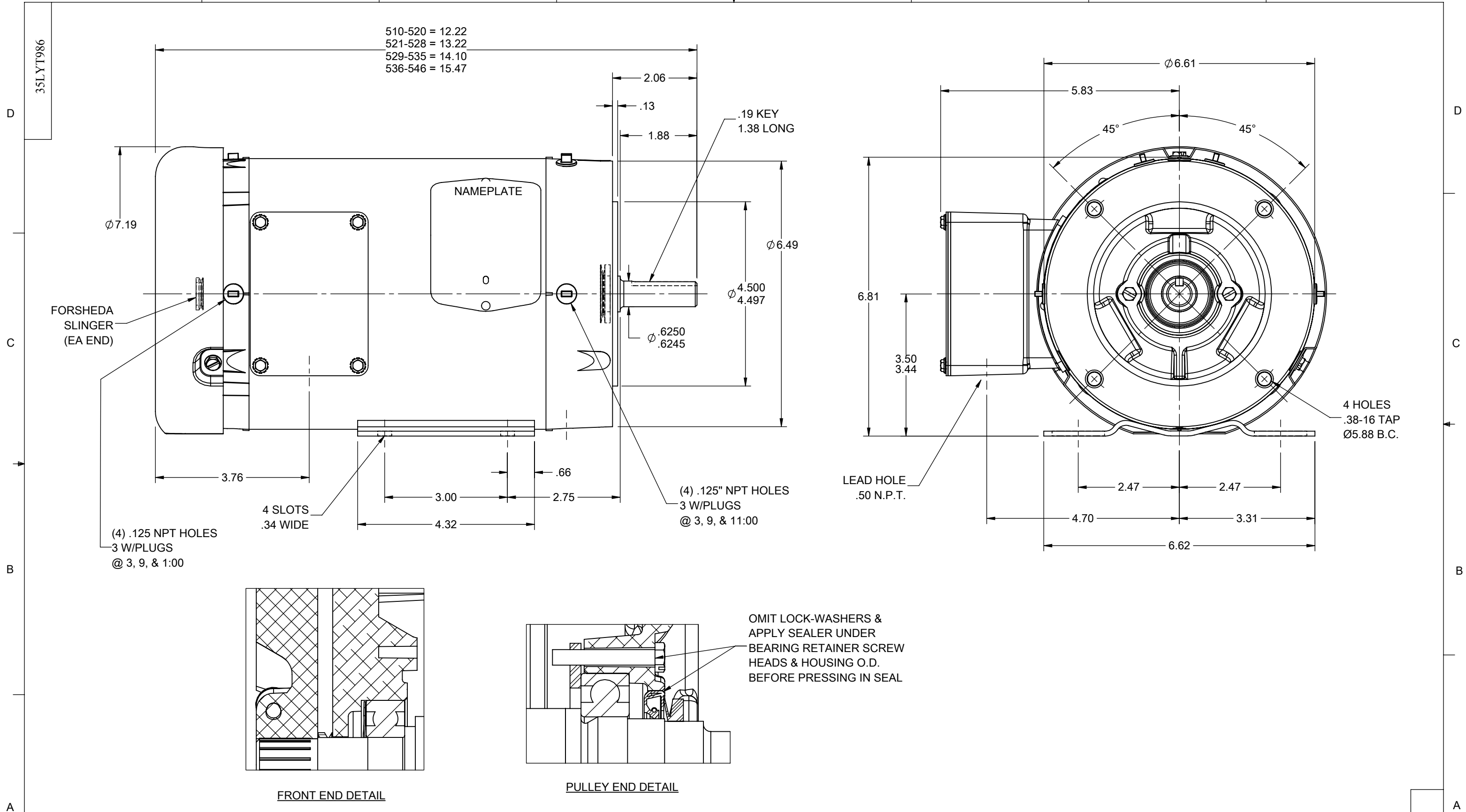

CUSTOMER IS RESPONSIBLE FOR DETERMINING THAT THE PRODUCT WILL PERFORM SUITABLY IN THE INTENDED APPLICATION

REV. DESC: CHG SEAL TO HAVE LIP OUT			
REV: H	VERSION: 08	REVISED: 09:25:35 02/14/2019	TDR: 000001099543
MODEL NO. 35LYT986		REF: -	
BY: ENWINB0			

BALDOR - RELIANCE®

HOR 56C TEFC 35M WD (S/P #9) 2P
SH 1 of 1

35LYT986