

8 7 6 5 4 3 2 1

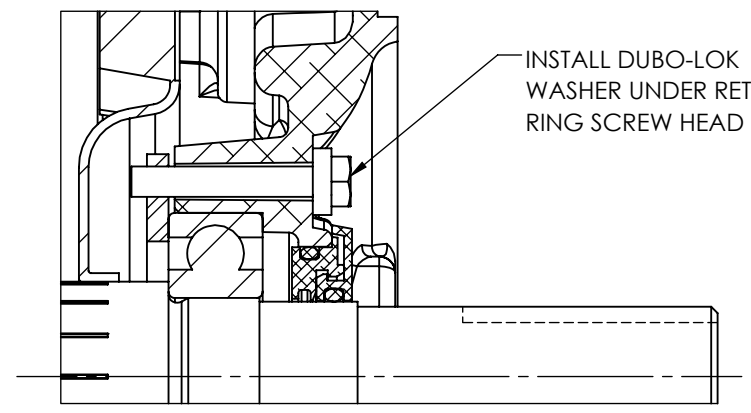
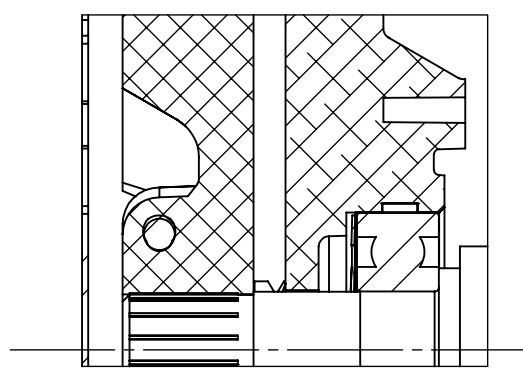
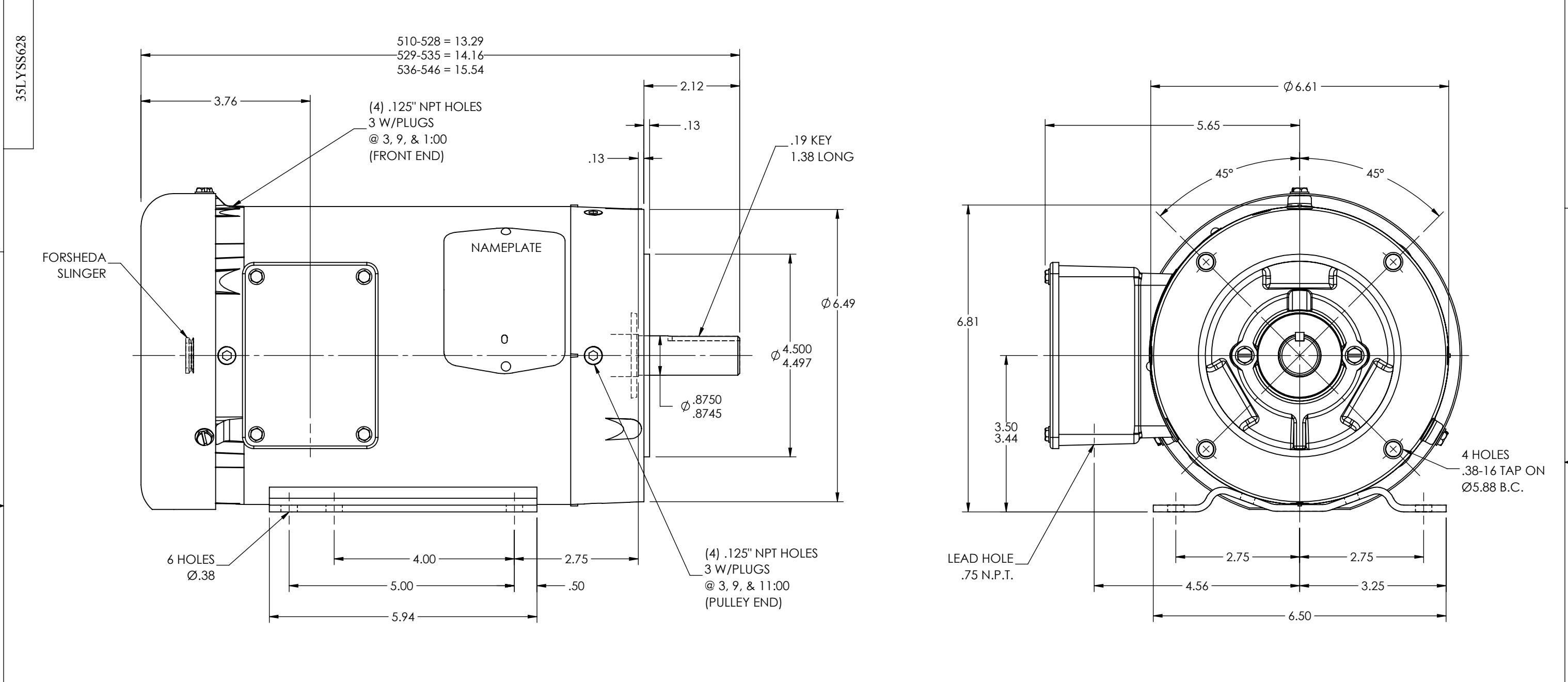

CUSTOMER IS RESPONSIBLE FOR DETERMINING THAT THE PRODUCT WILL PERFORM SUITABLY IN THE INTENDED APPLICATION

REV. DESC: LOADING OF SWD DWG FOR 2D TO 3D CONVERSION PKG 15			
REV: D	VERSION: 04	REVISED: 01:35:38 01/21/2019	TDR: 000001096905
MODEL NO. 35LYSS628			REF: -
BY: ENALEM0			<b>B</b>

**BALDOR - RELIANCE®**

STD HORZ 143-5TC TEFC 35M WD2 (PAINT FREE) W/.75 NPT LEAD HO  
SH 1 of 1

35LYSS628

8 7 6 5 4 3 2 1