

DUTY MASTER ALTERNATING CURRENT MOTORS

SQUIREL-CAGE INDUCTION

ENCLOSURE: TOTALLY ENCLOSED
 MOUNTING: FOOT, NEMA "C" FACE
 FRAMES 250TC THRU 440TC

COOLING: FAN COOLED
 CAST IRON CONSTRUCTION

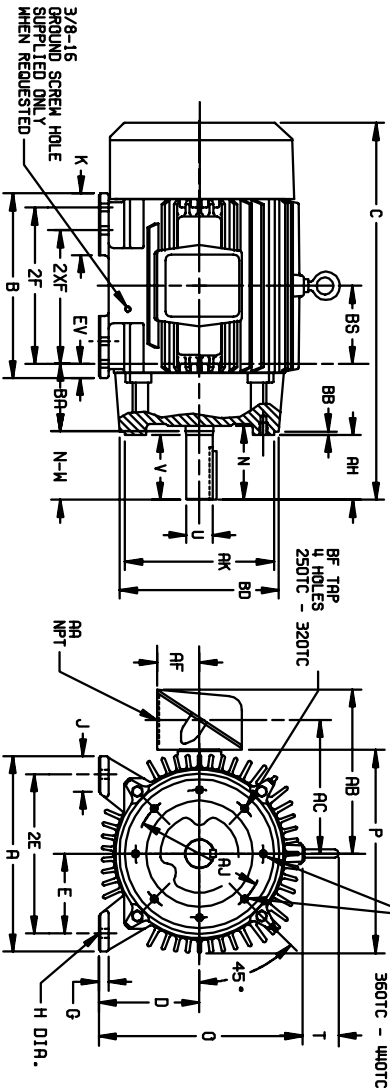

DIMENSIONS ARE IN INCHES, SEE SHEET 2 FOR DIMENSIONS IN MILLIMETERS

FRAME	A	D(2)	E	G	H	J	K	EV	O	P	T	CAST IRON TERMINAL BOX										MIN. TAP DEPTH	AJ	AK
												AA	AB	AC	AF	BA	BB	BD	BF	BF	BF			
254TC-256TC	12.50	6.25	5.00	.75	.56	2.50	---	1.00	13.25	13.25	2.44	1-1/2	4.10	8.1	8.1	2.50	4.75	2.5	9.00	1.72	1.3	.75	7.25	8.500
284TC-296TSC	13.75	7.00	5.50	.75	.56	2.50	---	1.00	14.75	14.88	2.44	1-1/2	212.62	10.19	3.00	4.75	2.5	11.25	1.2	1.3	.75	9.00	10.500	
324TC-326TSC	15.50	8.00	6.25	.88	.69	2.75	4.50	1.38	16.69	17.00	2.44	2	15.44	11.69	3.62	5.25	2.5	13.12	1.5	1.8	1.1	.94	11.00	12.500
364TC-365TSC	17.00	9.00	7.00	.98	.69	2.75	3.88	1.38	18.50	19.50	2.94	3	18.00	13.81	4.12	5.88	2.5	13.00	1.5	1.8	1.1	.94	11.00	12.500
404TC-405TSC	19.00	10.00	8.00	1.12	.81	3.25	4.62	1.13	21.31	22.50	2.94	3	19.25	15.06	4.12	6.82	2.5	13.12	1.5	1.8	1.1	.94	11.00	12.500
444TC-445TSC	21.00	11.00	9.00	1.12	.81	3.25	5.25	1.25	23.38	25.25	3.25	3	22.19	17.44	6.00	7.50	2.5	16.75	1.5	1.8	1.1	.94	14.00	16.000

FRAME SIZE	C	BS	B	2F	2VF	N	AH	SHAFT AND KEY					WEIGHT LBS. (5)
								N-W(7)	U(3)	V	SQ.	LGTH	
254TC	25.06	5.00	12.00	---	8.25	4.06	3.75	4.00	1.625	3.75	.375	2.88	3.45
256TC	25.06	5.00	12.00	10.00	---	4.06	3.75	4.00	1.625	3.75	.375	2.88	3.55
284TC	27.44	5.50	13.00	---	9.50	5.00	4.38	4.62	1.875	4.38	.500	3.25	4.85
284TSC	26.06	5.50	13.00	---	9.50	3.62	3.00	3.25	1.625	3.00	.375	1.88	4.85
286TC	27.44	5.50	13.00	11.00	---	5.00	4.38	4.62	1.875	4.38	.500	3.25	5.00
296TSC	26.06	5.50	13.00	11.00	---	3.62	3.00	3.25	1.625	3.00	.375	1.88	5.00
324TC	30.44	6.00	14.75	---	10.50	5.62	5.00	5.25	2.125	5.00	.500	3.88	6.05
324TSC	28.94	6.00	14.75	---	10.50	4.12	3.50	3.75	1.875	3.50	.500	2.00	6.05
326TC	30.44	6.00	14.75	12.00	---	5.62	5.00	5.25	2.125	5.00	.500	3.88	6.45
326TSC	28.94	6.00	14.75	12.00	---	4.12	3.50	3.75	1.875	3.50	.500	2.00	6.45
364TC	33.44	6.12	15.00	---	11.25	6.25	5.62	5.88	2.375	5.62	.625	4.25	8.80
364TSC	31.31	6.12	15.00	---	11.25	4.12	3.50	3.75	1.875	3.50	.500	2.00	8.74
365TSC	33.44	6.12	15.00	12.25	---	6.25	5.62	5.88	2.375	5.62	.625	4.25	9.05
365TSC	31.31	6.12	15.00	12.25	---	4.12	3.50	3.75	1.875	3.50	.500	2.00	8.89
404TC	38.31	6.88	16.00	---	12.25	7.50	7.00	7.25	2.875	7.00	.750	5.62	12.85
404TSC	35.31	6.88	16.00	---	12.25	4.00	4.25	4.25	2.125	4.00	.500	2.75	12.85
405TSC	38.31	6.88	16.00	13.75	---	7.50	7.00	7.25	2.875	7.00	.750	5.62	13.05
405TSC	35.31	6.88	16.00	13.75	---	4.25	2.125	4.00	2.125	4.00	.500	2.75	12.86
444TSC	44.82	8.25	19.00	---	14.50	8.94	8.25	8.50	3.375	8.25	.875	6.88	17.98
445TSC	40.88	8.25	19.00	---	14.50	5.19	4.50	4.75	2.375	4.50	.625	3.00	17.22
445TSC	44.82	8.25	19.00	16.50	---	8.94	8.25	8.50	3.375	8.25	.875	6.88	19.28
445TSC	40.88	8.25	19.00	16.50	---	5.19	4.50	4.75	2.375	4.50	.625	3.00	19.12

- (1) SPECIAL DIMENSIONS APPLYING TO THIS ORDER ON THIS LINE.
 - (2) "D" VARIES - 250TC - 320TC +.00, -.03
 360TC - 440TC +.00, -.06
 - (3) "U" VARIES - HP TO 1.625 DIA. +.000, -.0005
 1.625 AND LARGER +.000, -.001.
 - (4) ALL FRAMES HAVE EIGHT MOUNTING HOLES FOR DUAL MOUNTING.
 - (5) MOTOR WEIGHTS MAY VARY BY 15% DEPENDING UPON RATING.
 - (6) "AK" VARIES - 250TC - 280TC +.000, -.003
 320TC - 440TC +.000, -.005
 - (7) "N-W" VARIES +.00, -.25.
- CONDUIT BOX LOCATED ON OPPOSITE SIDE WHEN F-2, W-1, W-4, W-5, W-7, OR C-1 MOUNTING IS SPECIFIED.
- IF MOUNTING CLEARANCE DETAILS ARE REQUIRED, CONSULT FACTORY.
- MAXIMUM PERMISSIBLE SHAFT RUNOUT WHEN MEASURED AT END OF STD. SHAFT EXTENSION IS .002 T.I.R. UP TO AND INCLUDING 1.625 DIA. AND .003 T.I.R. 1.625 DIA. TO 5 INCH DIA.
- FACE RUNOUT AND - 250TC - 280TC INCL. .004 MAX. T.I.R. ECCENTRICITY - 320TC - 440TC INCL. .007 MAX. T.I.R.

CUSTOMER IS RESPONSIBLE FOR DETERMINING THAT MOTOR PERFORMANCE IS SUITABLE IN THE APPLICATION.

REV. DESC: REMOVING TITLEBLOCK		
REV. LTR: A	VERSION: 01	TDR: 000000448517
FILE: \RAG\00004\530	REVISED: 14:21:04 11/07/2007	BY: CONBPM
MTL: -		

BALDOR • DODGE • RELIANCE

DIM SHT 250TC-440TC TEFC FT MTG C FACE T & TS SGL EXT XT

FRAME - _____ TYPE - _____ CERTIFIED FOR - _____ RPM - _____ PH - _____ HZ _____ VOLTS _____

ORDER - _____ ITEM - _____ HP - _____ APPROVED BY - _____ DATE _____

SALES ORDER - _____

IHS-505-047119