

DUTY MASTER ALTERNATING CURRENT MOTORS

SQUIRREL-CAGE INDUCTION

617428-693

ENCLOSURE: UNDERWRITER MOTOR

MOUNTING: FOOT, F-1

E365TS/E364TS FRAME MOUNTING HOLES

COOLING: FAN COOLED

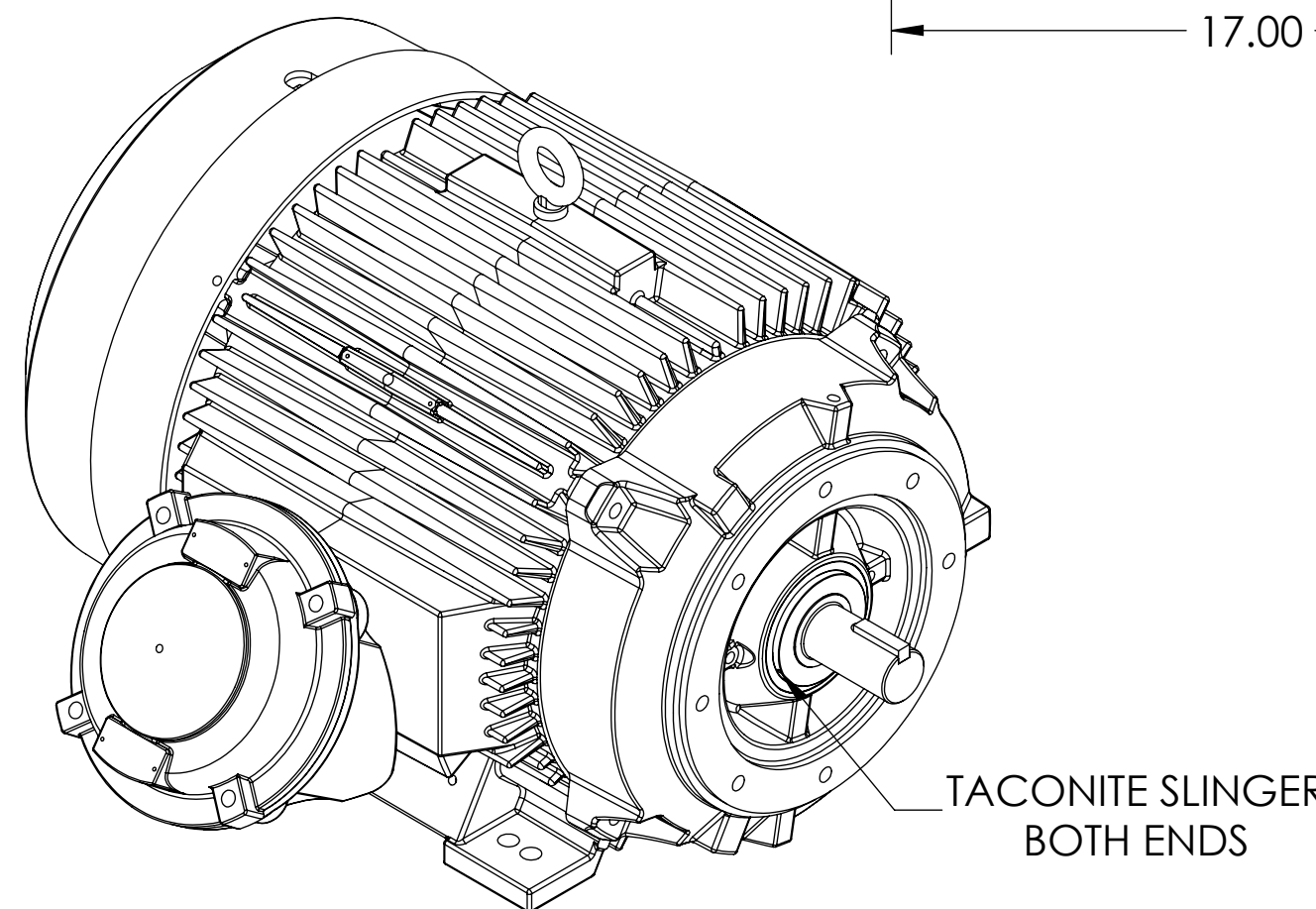
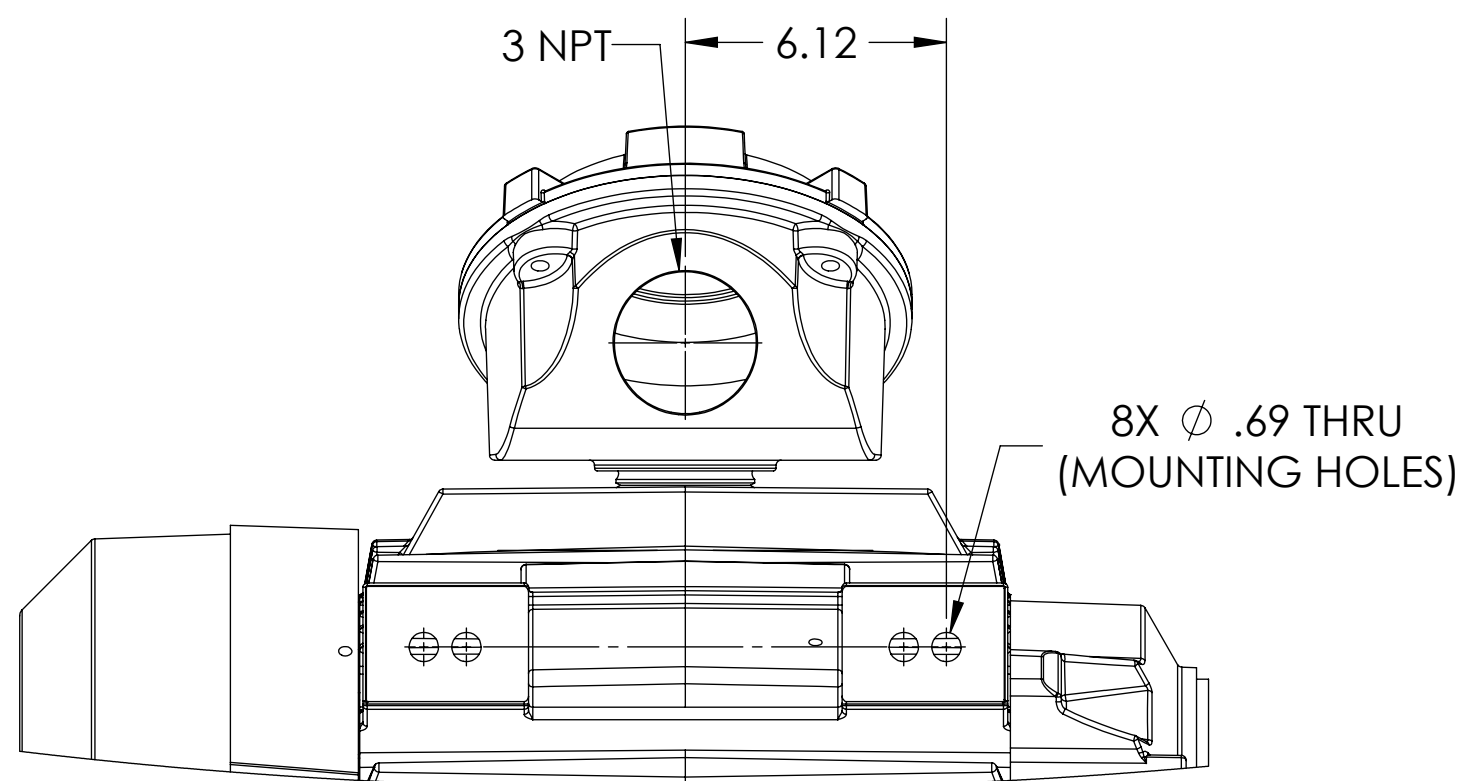
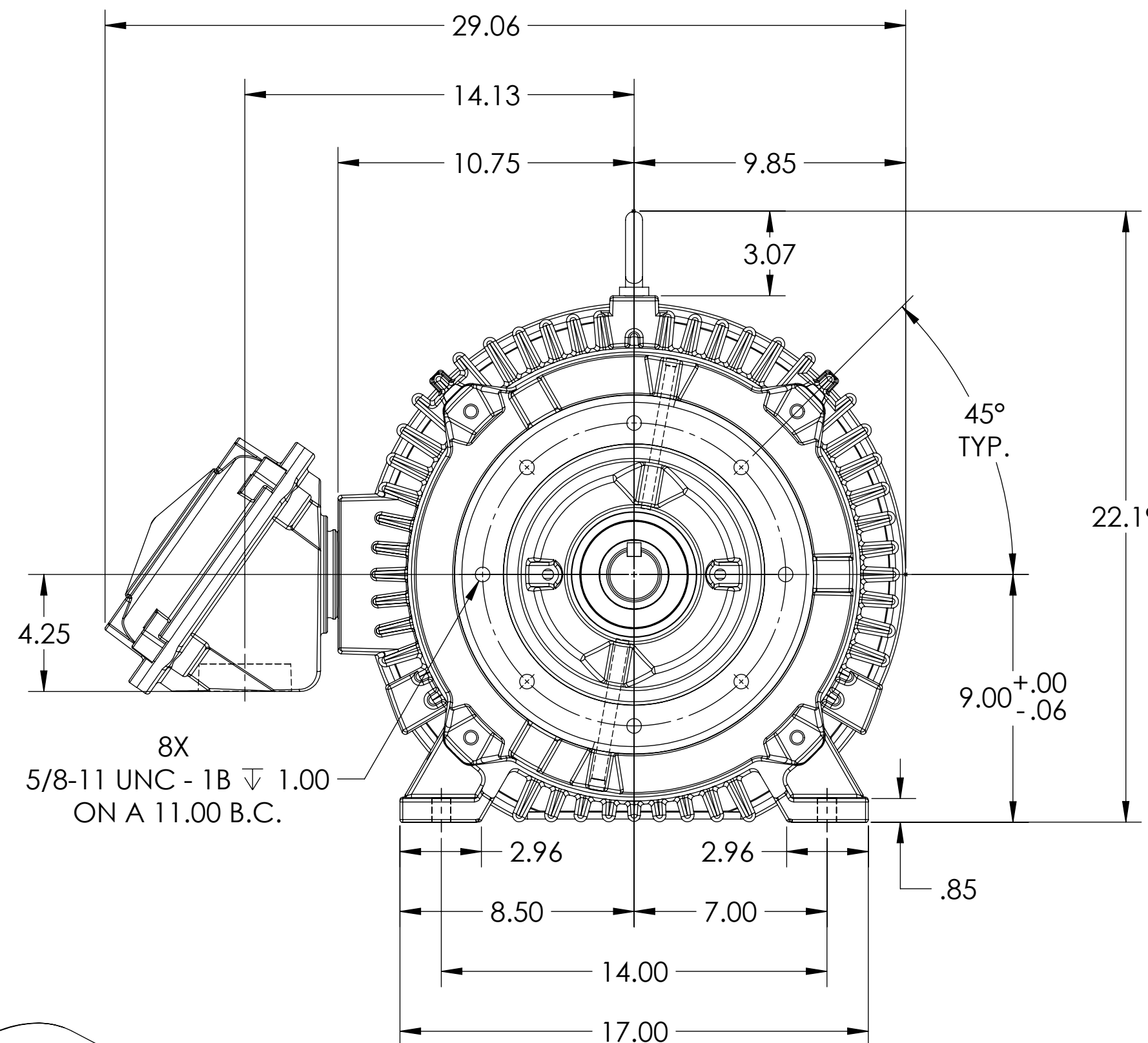
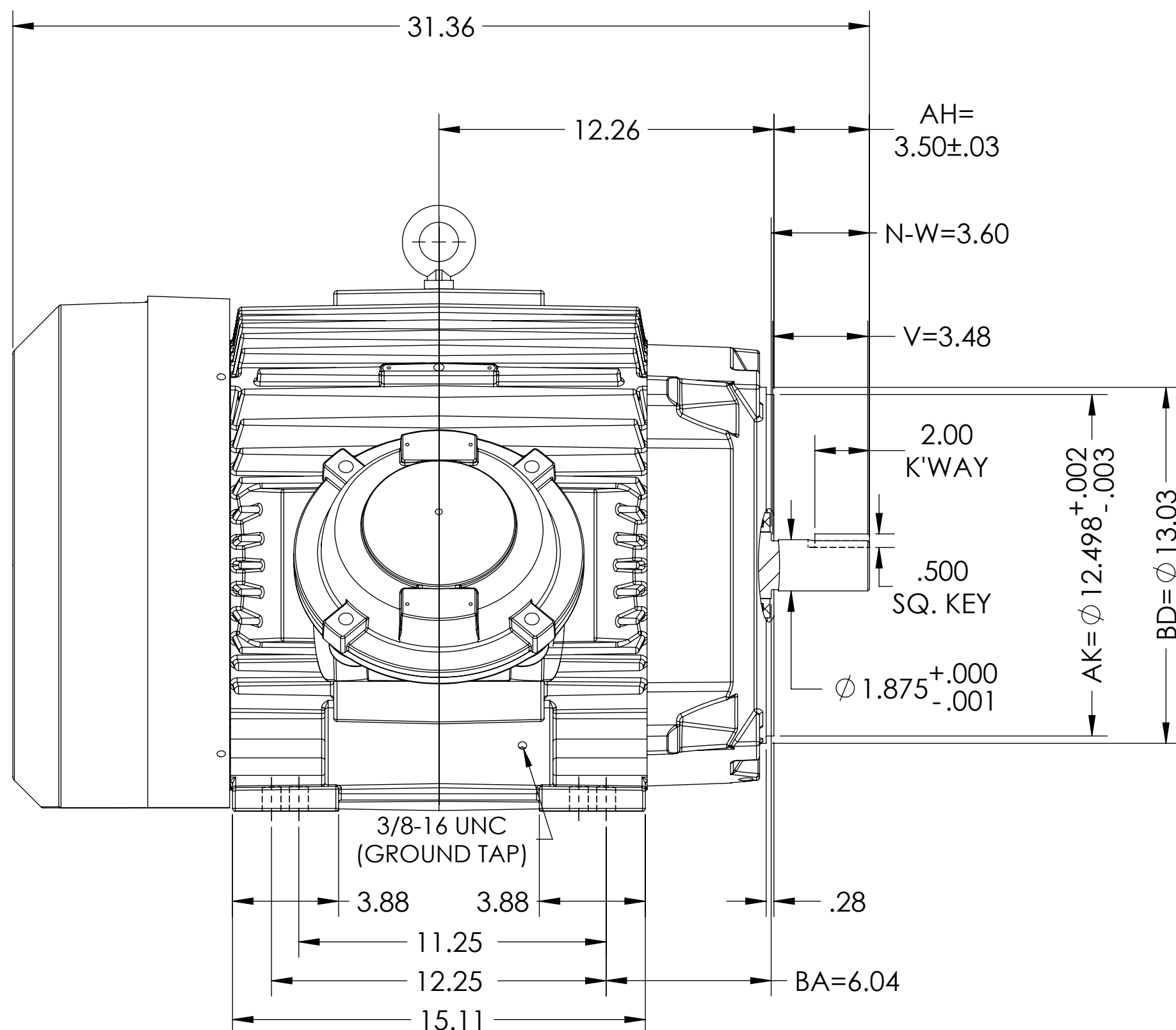

DIMENSIONS ARE IN INCHES.
CUSTOMER IS RESPONSIBLE FOR DETERMINING THAT MOTOR PERFORMANCE IS SUITABLE IN THE APPLICATION.

REV. DESC: NEW DRAWING			
REV: -	VERSION: 00	REVISED: 11:14:45 04/16/2019	TDR: 000001105245
MODEL NO. 617428-693			
BY: USJEDIL			

BALDOR

E365/364TSC FCXP F1 FOOT CI BOX/TACONITE SLINGERS/GROUND TAP

FACE RUNOUT AND ECCENTRICITY .007 MAX T.I.R.
IF MOUNTING CLEARANCE DETAILS ARE REQUIRED, CONSULT FACTORY.
MAX PERMISSIBLE SHAFT RUNOUT WHEN MEASURED AT END OF STANDARD SHAFT EXTENSION IS .003" T.I.R.

617428-693

617428-693