

# DUTY MASTER ALTERNATING CURRENT MOTORS

## SQUIRREL-CAGE INDUCTION

617428-245

ENCLOSURE: UNDERWRITER MOTOR

MOUNTING: FOOT, F-1

E365TS/E364TS FRAME MOUNTING HOLES

COOLING: FAN COOLED

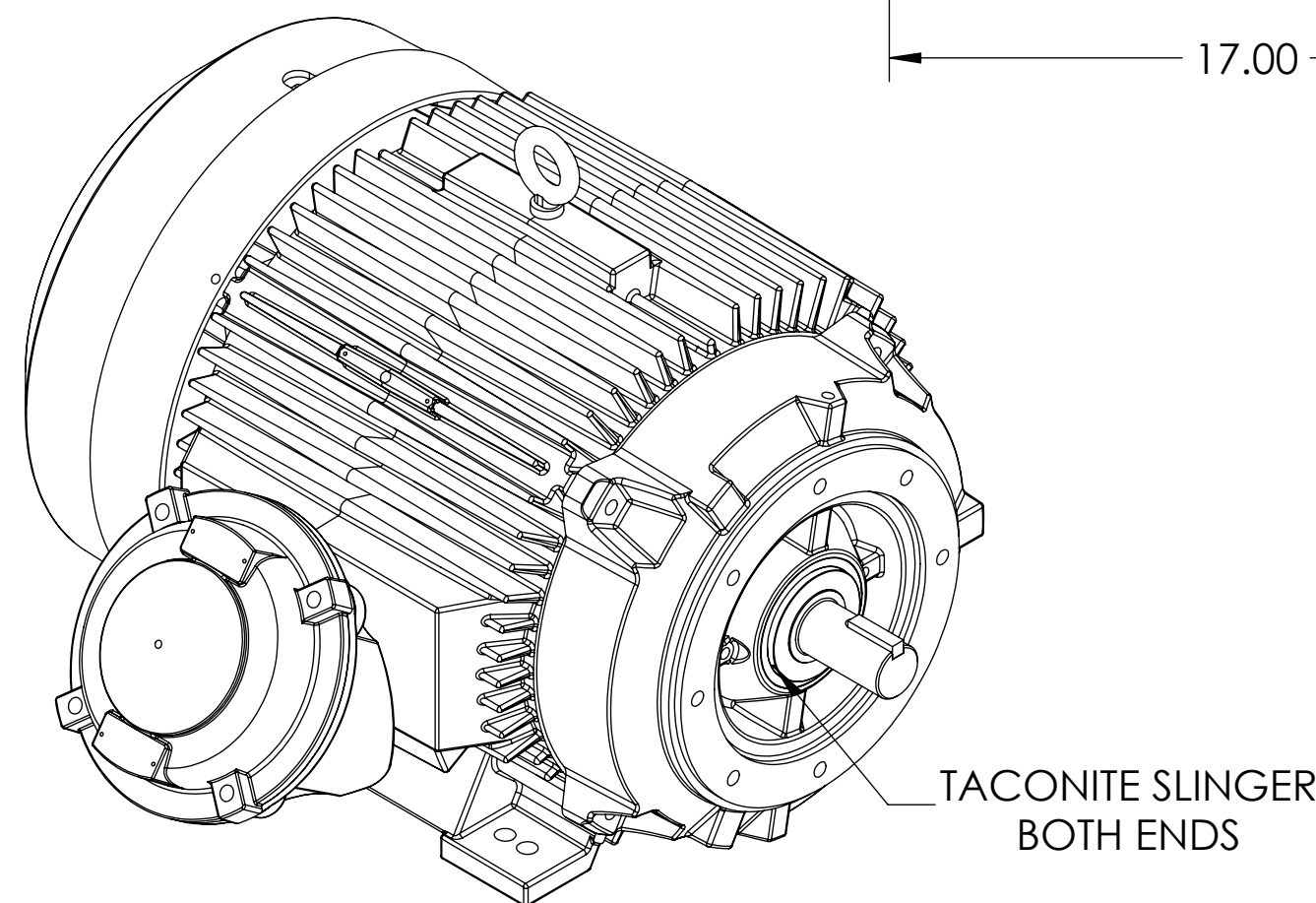
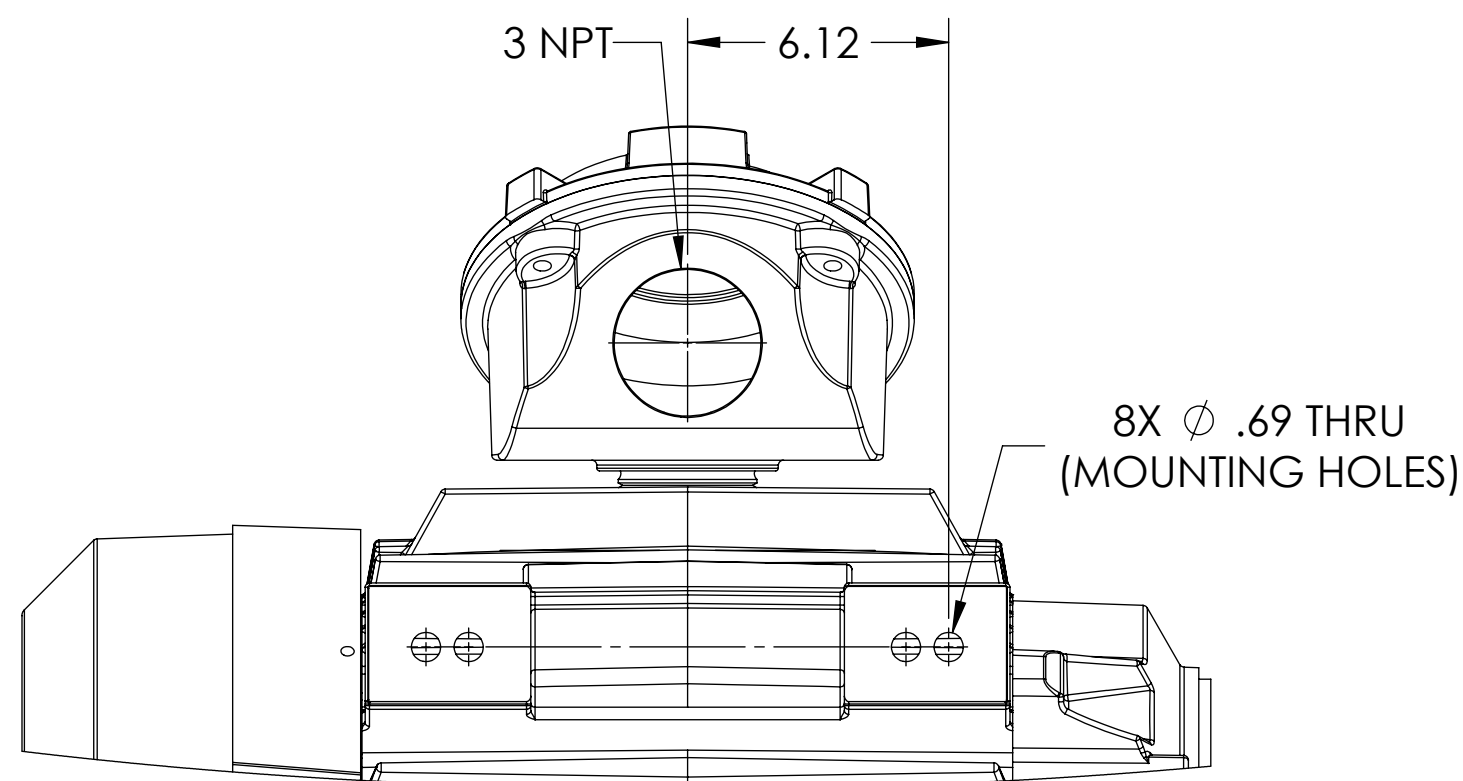
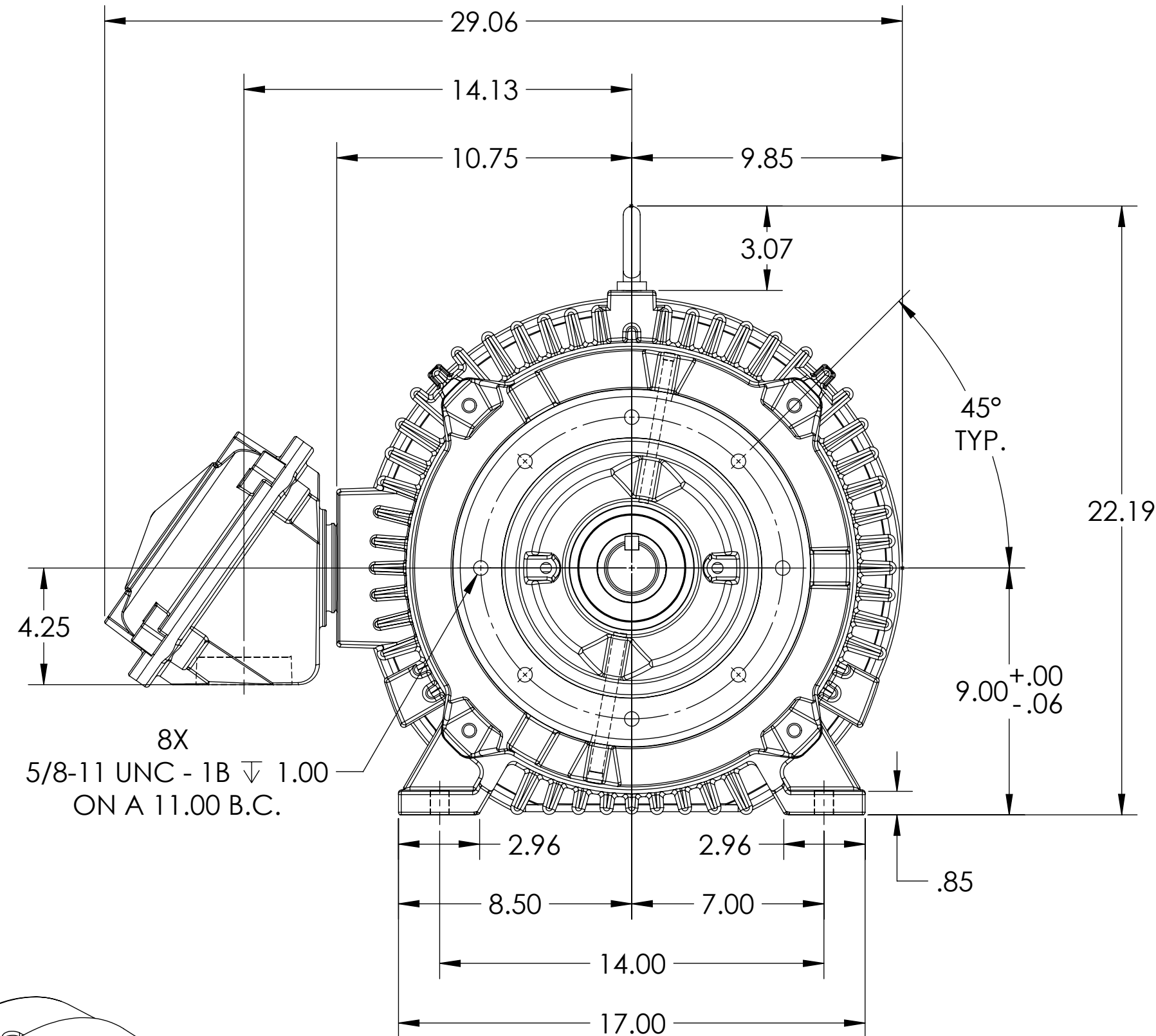
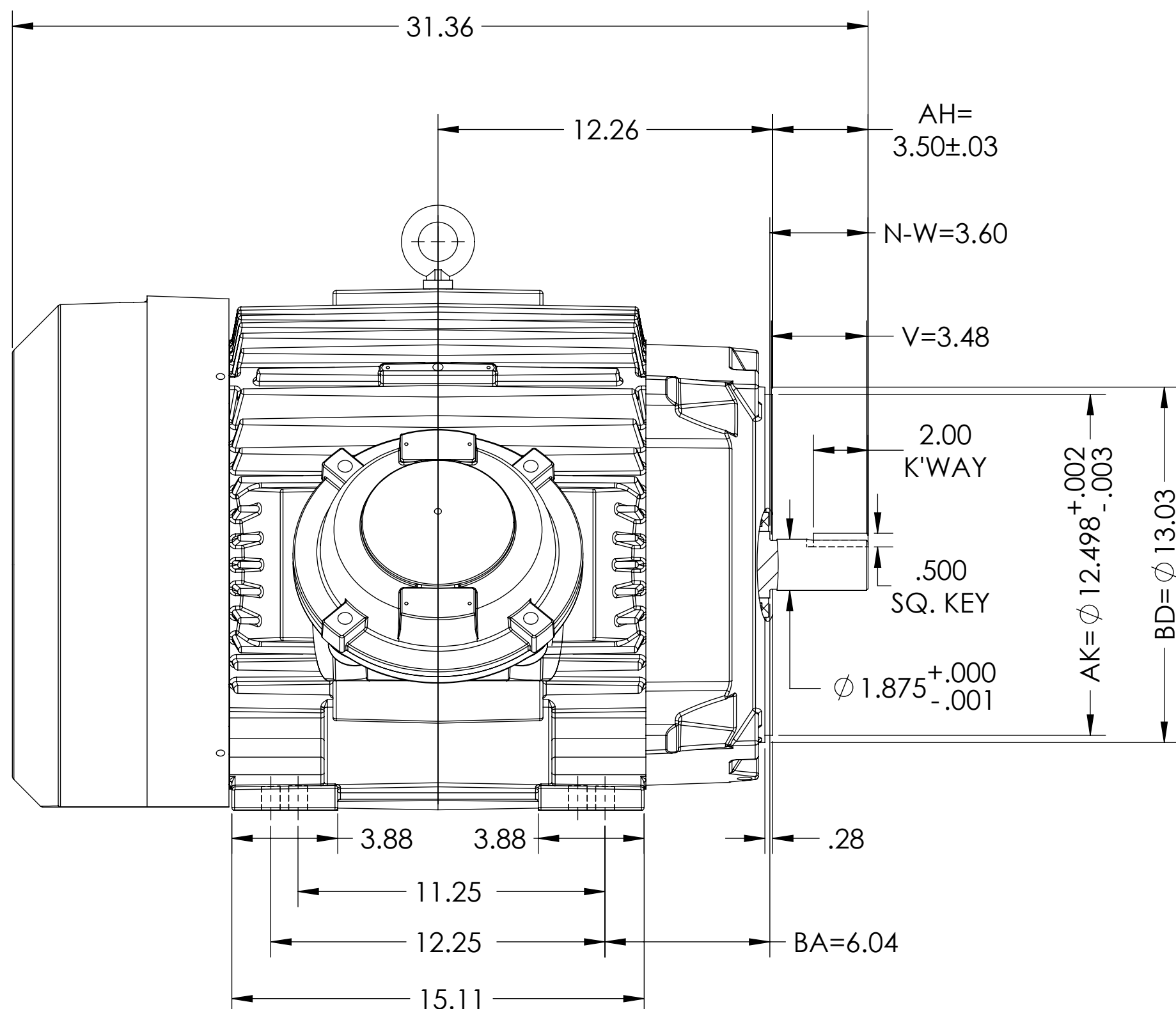

DIMENSIONS ARE IN INCHES.  
CUSTOMER IS RESPONSIBLE FOR DETERMINING THAT MOTOR PERFORMANCE IS SUITABLE IN THE APPLICATION.

REV. DESC: NEW DRAWING	VERSION: 00	REVISED: 09:17:35 08/21/2017	TDR: 000001038646
MODEL NO. 617428-245	BY: USJEDIL		

**BALDOR**

E365/364TSC FCXP F1 FOOT CAST IRON BOX/TACONITE SLINGERS

FACE RUNOUT AND ECCENTRICITY .007 MAX T.I.R.  
IF MOUNTING CLEARANCE DETAILS ARE REQUIRED, CONSULT FACTORY.  
MAX PERMISSIBLE SHAFT RUNOUT WHEN MEASURED AT END OF STANDARD SHAFT EXTENSION IS .003" T.I.R.

617428-245

617428-245