



A - MILLING

A - 08 | Milling tool selection

A - 10 | Coupling types

A - 11 | Milling tools codification

A - 12 | Milling tools overview

A - 36 | New Grades



MILLING



A - 38 | Inserts Overview
A - 56 | FACE MILLING
A - 88 | HIFEED MILLING
A - 124 | SHOULDER MILLING
A - 196 | PROFILE MILLING
A - 228 | HARDMILL

A - 230 | CENTER & CHAMFER
A - 232 | SPOT FACE
A - 234 | Spare Parts
A - 240 | Technical Data
A - 256 | PCD TIPPED END MILLS
A - 262 | SOLID CARBIDE END MILLS

MILLING TOOL SELECTION

1 - Define your operation type:

- Face milling
- Highfeed milling
- Shoulder milling
- Profile milling
- Hardmill

Select your tool:

See page A - 18

MILLING TOOLS OVERVIEW

HSA-MILLING COATED					HSA-MILLING COATED				
Series	PLUS 2008H	PLUS 9020H	PLUS 9045H	PLUS 9045H	Series	PLUS 9245H	LINEPRO 0064H	LINEPRO 0064H	LINEPRO 0055H
Image					Image				
Material	Al, Ti, In	Al, Ti, In	Al, Ti, In	Al, Ti, In	Image	Al, Ti, In	Al, Ti, In	Al, Ti, In	Al, Ti, In
Application	Face milling	Face milling	Face milling	Face milling	Image	Face milling	Face milling	Face milling	Face milling
Notes	For high speed cutting with high feed rates. Suitable for high speed cutting of Al, Ti, In.	For high speed cutting with high feed rates. Suitable for high speed cutting of Al, Ti, In.	For high speed cutting with high feed rates. Suitable for high speed cutting of Al, Ti, In.	For high speed cutting with high feed rates. Suitable for high speed cutting of Al, Ti, In.	Image	For high speed cutting with high feed rates. Suitable for high speed cutting of Al, Ti, In.	For high speed cutting with high feed rates. Suitable for high speed cutting of Al, Ti, In.	For high speed cutting with high feed rates. Suitable for high speed cutting of Al, Ti, In.	For high speed cutting with high feed rates. Suitable for high speed cutting of Al, Ti, In.

2 - Define your material according to ISO:

- P** Steel
- M** Stainless Steel
- K** Cast Iron
- N** Aluminium & Non Ferrous Materials
- S** Heat Resistant and Titanium Alloy
- H** Hardened Material

See the chapter General Technical Data on the last pages for Palbit Selection Materials - PSM

WORKPIECE MATERIALS - PALBIT SELECTION MATERIALS, PSM

ISO	Material	Application	Tool Type	Notes
P	C45	Medium carbon steel	Standard	Standard tooling
	304	Austenitic stainless steel	Special	High speed cutting
	420	Martensitic stainless steel	Special	High speed cutting
M	316	Austenitic stainless steel	Special	High speed cutting
	17-4PH	PH stainless steel	Special	High speed cutting
K	HT 200	Cast iron	Standard	Standard tooling
	HT 300	Cast iron	Standard	Standard tooling
	HT 400	Cast iron	Standard	Standard tooling
N	Al 6061	Aluminum	Standard	Standard tooling
	Al 7075	Aluminum	Special	High speed cutting
	Ti 6Al-4V	Titanium	Special	High speed cutting

3 - Select your milling cutter.

Choose the cutter pitch and mounting:

- Use a close pitch cutter as first choice
- Use a coarse pitch cutter for long overhang and unstable conditions
- Choose a mounting type
- The cutter marked as “stock available under request” has a minimum order quantity according to the following table:

Qty	* ØDc Size
10	≤ 100 mm
5	> 100 mm

TETRAFEED 16320

Technical drawing showing tool geometry and dimensions. Includes a table with columns for tool type, material, and application.

4 - Select your insert.

Choose the chip-breaker for your operation:

- Chip-breaker L= Light (for light cuts when low forces/power are required)
- Chip-breaker M = Medium (first choice for mixed production)
- Chip-breaker H = Heavy (for rough operations, forging, cast skin and vibration)
- Select insert grade for optimum productivity
- The insert marked as "stock available under request" has a minimum order quantity according to the following table:

Qty	*IC Size
300	≤ IC 25 mm
150	> IC 25 mm

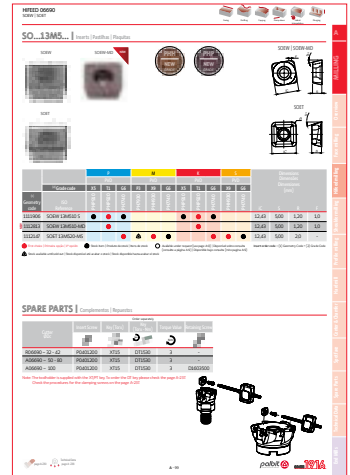

5 - Define your starting cutting parameters.

Cutting speeds and feeds for different materials are given on the insert boxes and in the tables for each solution.

The values should be optimized according to the machine and conditions.

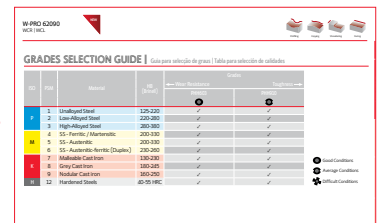

INSERTS CODIFICATION FOR MILLING HOLDERS

Codificação de pastilhas para fresas | Codificación de insertos para herramientas de fresado

Code	Inserts Description	Page	Code	Inserts Description	Page	Code	Inserts description	Page
000	PD...W 1204	82	202	XPET 1706	153	450	WNHU 060410	196
060	SE...T/W 1204	76	245	RDHW 0702	217	490	WNHU 04T3...	125 196
062	SP...X 1204	178	250	RD...T/W 1003 MO	217	495	WNXT 0806...	121
063	POKT 0403	89	251	RD...T/W 12T3MO	217	500	WNMW 1207	113
064	SOEW SOET 0803...	93	252	RD...T/W 1604MO	217	505	WDET WDMW 1204...	109
065	SPKT/W 08T308	117	253	RD...T/W 2006MO	217	620	WCL(R)...	191 192
066	SOEW SOET 13M...	99	280	SN...U 1206	57	630	XPGT 3206...	194
068	SOEW SOET 1605...	104	335	RD...0802	203	720	XNHW 1205...	229
083	VCGX 220530	176	336	RP...10T3	203	760	XDGX 15M5	169
099	SE...T/W 13T3	79	337	RP...1204	203	770	XDGX 22M7	173
163	XNKU 06T3	85	338	RP...1605	203	900	LNXT 0904	158
170	AP...T 1003	181	339	RP...2006	203	901	LNXT 1306	161
171	ANHX 1004	126	341	RPHT 10T3-LS(4)	205	902	PN...X 1105	61
175	ANHX 1204	132	342	RPHT 1204-LS(4)	205	903	LNXT 1506	165
180	AP... 1604	187	351	RN...1204	211	908	SN...X 1206 & ON...X 0505	65
181	ANHX 1607	135	400	XDHW 060210	223	909	SN...X 1206	69
200	XP... 0602	139	405	XDHW 10T310	223	912	SN...X 1606 & ON...X 0606	73
201	XP... 1003	147	410	XDHW 040110	223			

COUPLING TYPES

A Tipo de acoplamento | Tipo de acoplamiento

Symbol Símbolo Símblo	Coupling type Tipo de acoplamento Tipo de acoplamiento	Inserts fixation type Fixação de pastilhas Fijación de plaquitas	Standard Norma Norma
A	Arbor mounting Montagem tipo árvore Montaje tipo husillo	Insert screw Parafuso pastilha Tornillo de la plaquita	ISO 6462
B		Wedge Cunha Cuña	ISO 6462
C		Insert screw and washer, Screw clamp or clamp Parafuso para pastilha e anilha, parafuso e grampo ou grampo Tornillo de la plaquita y arandela, tornillo y brida o brida	ISO 6462
D		Washer Anilha Arandela	ISO 6462
E	Cylindrical shank Haste cilíndrica Mango recto	Any type Qualquer tipo Cualquier tipo	DIN 1835 - A
R	Threaded coupling Acoplamento roscado Acoplamiento tipo tornillo	Any type Qualquer tipo Cualquier tipo	Palbit internal standard Norma interna Palbit
W	Weldon shank Haste weldon tipo mango	Any type Qualquer tipo Cualquier tipo	DIN 1835 - B
X	Special coupling Acoplamento especial Acoplamiento especial	Any type Qualquer tipo Cualquier tipo	

ISO ARBOR MOUNTING TYPES | Estilos de montagem ISO tipo árvore | Estilos de montaje ISO tipo husillo

Arbor type A

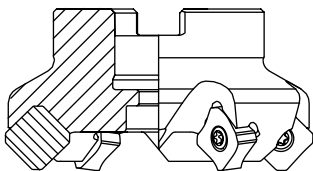

Arbor type B

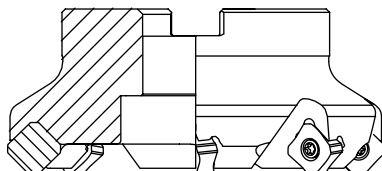

Arbor type C

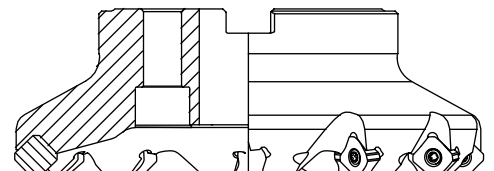

NOTE: For each type of arbor mounting (see previous table of coupling type on symbols A, B, C, D), we can have a different arbor types (see images above).

MILLING TOOLS CODIFICATION

Codificação das ferramentas de fresagem | Codificación de heramientas de fresado

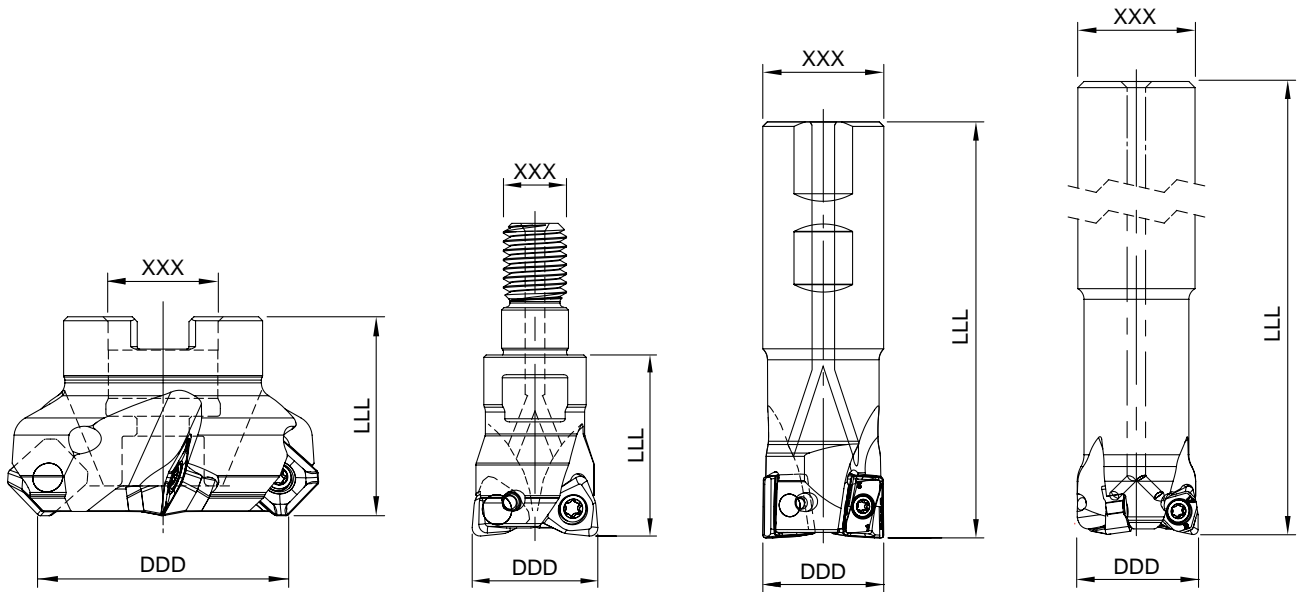

DDD Y ZZZ TT-NN-LL U XXX LLL-L-AAA # #

Diameter
Diâmetro
Diámetro

Coupling Type (A-10)
Tipo de acoplamento (A-10)
Tipo de acoplamiento (A-10)

Insert Type (A-9)
Pastilha aplicável (A-9)
Inserto aplicable (A-9)

Lead angle
Ângulo de posicionamento da pastilha
Ángulo de posicion del inserto

Number of teeth
Número de dentes
Numero de dientes

Axial angle (angle of the tool construction)
Ângulo Axial (ângulo de construção da ferramenta)
Ángulo Axial (ángulo de la construcción de herramienta)

Cooling system
Refrigeração
Refrigeración
U - Without cooling system
U - Sem refrigeração
U - Sin refrigeración

Coupling diameter
Diâmetro de acoplamento
Diámetro de acoplamiento

Total length
Comprimento total
Longitud total

Rotation (R/L)
Rotação (R/L)
Rotación (R/L)
*In case of right rotation the "R" is suppressed.

Depth of cut
Profundidade de corte
Profundidad del corte
*In case it is a helical cutter

Number of inserts
Número de pastilhas
Número de insertos
*In case it is a helical cutter

A

MILLING

Overview

Face milling

Hi-feed milling

Shoulder milling

Profile milling

Hardmill

Center & Chamfer







































































Spot face

Spare Parts

Technical Data

End Mills

MILLING TOOLS OVERVIEW

A	MILLING	LINEPRO	LINEPRO	LINEPRO ^{NEW}	P. HIFEED	HIFEED	HIFEED	HIFEED	HIFEED	ALUPRO	LINEPRO	TETRAFEED ^{NEW}	LINEPRO
		00036	06045	06290	06320	06410	06590	06690	06815	08390	09945	16320	17090
Overview	Page	82	76	178	88	92	116	98	104	176	78	84	180
Face milling	Insert	PD... 1204...	SE... 1204...	SP... 1204...	POKT 0403...	SO... 0803...	SP... 08T3...	SO... 13M5...	SO... 1605...	VCGX 2205...	SE... 13T3...	XNKU... 06...	AP... 1003...
Hifeed milling	Arbor mouting	Ø 66-160	Ø 50-160	Ø 40-160	Ø 40-66	-	-	Ø 50-100	Ø 63-160	-	Ø 50-250	Ø 40-63	Ø 40-63
Shoulder milling	Weldon Shank	-	-	-	-	Ø 20-32	Ø 20-32	-	-	-	-	Ø 16-32	Ø 16-25
Profile milling	Cylindrical Shank	-	-	-	Ø 20-40	-	-	-	-	-	-	-	-
Hardmill	Threaded Coupling	-	-	-	Ø 16-42	Ø 20-42	Ø 20-42	Ø 32-42	-	Ø 32	-	Ø 16-42	Ø 16-25
Center & Chamfer	 Facing												
Spot face	 Shouldering												
End Mills	 Slanted Shoulder & Chamfer												
	 Ramp down												
	 Helical Interpolation												
	 Plunging												
	 Side milling												
	 Slotting												
	 Profiling												
	 Copying												
	 Plunging & Recessing												

 Main Operation

 Other Operations

	PLUS 17190	PLUS 17590	LINEPRO 18090	PLUS 18190	LINEPRO 20090	LINEPRO 20190	LINEPRO 20290	TOROMILL 24590	TOROMILL 25090	TOROMILL 25190	TOROMILL 25290	TOROMILL 25390	PLUS 28088
	126	130	186	134	138	144	152	214	214	214	216	216	56
	ANHX 1004...	ANHX 1206...	AP... 1604...	ANHX 1607...	XPET 0602...	XPET 1003...	XPET 1706...	RD... 0702...	RD... 1003...	RD... 12T3...	RD... 1604...	RD... 2006..	SN...U 1206...
	Ø 40-100	Ø 40-125	Ø 40-125	Ø 50-160	-	Ø 40-63	Ø 40-125	-	Ø 42-52	Ø 50-80	Ø 52-160	Ø 80-160	Ø 50-200
	Ø 14-40	Ø 25-40	Ø 25-40	Ø 32-40	-	Ø 16-27	Ø 32-40	Ø 15	Ø 20	Ø 25	-	-	-
	-	Ø 26-33	-	-	Ø 10-21	-	-	-	-	-	-	-	-
	-	Ø 25-42	-	Ø 32-40	Ø 10-32	Ø 16-40	-	Ø 15-20	Ø 20-42	Ø 24-42	Ø 32-35	-	-
					 (only with XPET-HF)	 (only with XPET-HF)							

A

MILLING

Overview

Face milling

Hifed milling

Shoulder milling

Profile milling

Hardmill

Center & Chamfer

Spot face

Spare Parts

Technical Data

End Mills

MILLING TOOLS OVERVIEW

		TOROMILL 33590	TOROMILL 33690	TOROMILL 33890	TOROMILL 33990	TURBOMILL ^{NEW} 34190	TURBOMILL ^{NEW} 34290	TOROMILL X2 35190	LINEPRO 40095	LINEPRO 40595	LINEPRO 41095	PLUS 45095
MILLING	Page	200	200	202	202	204	204	210	222	222	222	198
	Insert	RDHT 0802...	RPHT 10T3...	RPHT 1605...	RPHT 2006...	RPHT 10T3...LS(4)	RPHT 1204...LS(4)	RNHX 1204...	XD... 0602...	XD... 10T3...	XD... 0401...	WNHU 0604...
Overview	Arbor mouting	-	-	Ø 50-125	Ø 80-125	Ø 42-52	Ø 40-80	Ø 40-80	-	Ø 52-80	-	-
	Weldon Shank	-	-	-	-	-	-	Ø 32	-	-	-	-
Face milling	Cylindrical Shank	Ø 16-25	Ø 20-32	-	-	-	-	-	-	-	-	-
	Threaded Coupling	Ø 16-32	Ø 20-35	-	-	-	-	Ø 32-42	Ø 16-25	Ø 25-42	Ø 10-12	Ø 25-42
Hifeed milling	 Facing											
Shoulder milling	 Shouldering											
Profile milling	 Slanted Shoulder & Chamfer											
	 Ramp down											
Hardmill	 Helical Interpolation											
Center & Chamfer	 Plunging											
	 Side milling											
Spotface	 Slotting											
Spare Parts	 Profiling											
Technical Data	 Copying											
	 Plunging & Recessing											

 Main Operation

 Other Operations

	PLUS 49090	PLUS 49095	NEW HEXAPLUS 49590	HIFEED 50060	HIFEED 50560	NEW W-PRO 62090	NEW BALLPRO 63090	HARDMILL 72090	ALUPRO 76090	ALUPRO 77090	TGPLUS 90090	TGPLUS 90190
	124	196	120	112	108	190	194	226	168	172	156	160
	WNHU 04T308-LP	WNHU 04T3...	WNXT 0806...	WN... 1207...	WD... 1204...	WC... 08...	XPXT 3206...	XNHW 1205...	XDGX 15M5...	XDGX 22M7...	LNXT 0904...	LNXT 1306...
	-	-	Ø 40-125	Ø 52-80	Ø 52-80	-	-	Ø 40-160	Ø 40-100	Ø 50-125	Ø 40-63	Ø 40-125
	-	-	Ø 32-50	-	-	-	-	-	-	-	Ø 16-32	Ø 25-40
	Ø 16-25	-	-	-	-	Ø 8-20	-	-	Ø 20-40	Ø 32-40	Ø 25-32	Ø 25-40
	Ø 16-32	Ø 16-35	-	Ø 35	-	-	Ø 32	-	-	-	Ø 25-32	-

A

MILLING

Overview

Face milling

Hifeed milling

Shoulder milling

Profile milling

Hardmill

Center & Chamfer

Spot face

Spare Parts

Technical Data

End Mills

MILLING TOOLS OVERVIEW

	PLUS 90260	TGPLUS 90390	PLUS 90845	PLUS 90945	PLUS 91245
Page	60	164	64	68	72
Insert	PN... 1105...	LNXT 1506...	SN... 1206... ON... 0505...	SN...1206...	SN... 1606... ON... 0606...
Arbor mouting	Ø 50-160	Ø 50-160	Ø 50-250	Ø 50-250	Ø 63-250
Weldon Shank	-	-	Ø 32-40	-	-
Cylindrical Shank	-	-	-	-	-
Threaded Coupling	-	-	-	-	-
 Facing					
 Shouldering					
 Slanted Shoulder & Chamfer					
 Ramp down					
 Helical Interpolation					
 Plunging					
 Side milling					
 Slotting					
 Profiling					
 Copying					
 Plunging & Recessing					

 Main Operation

 Other Operations

NEW W-PRO 62090 = NEW GRADE PHH

Nova linha W-PRO 62090 - Novo grau PHH | Nueva línea W-PRO 62090 - Nueva calidad PHH

The new W-PRO is the combination of the most refined inserts and the most stable shanks. When looking for a finishing solution for Steels, Stainless Steels, Cast Irons, HRSA or Hardened Steels that can work for a long time while delivering a flawless machined surface, this is the best solution.

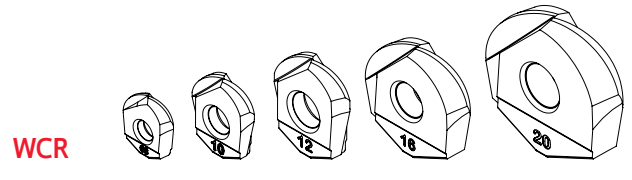
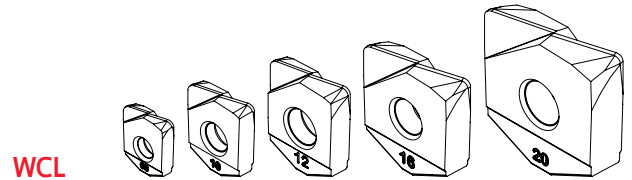
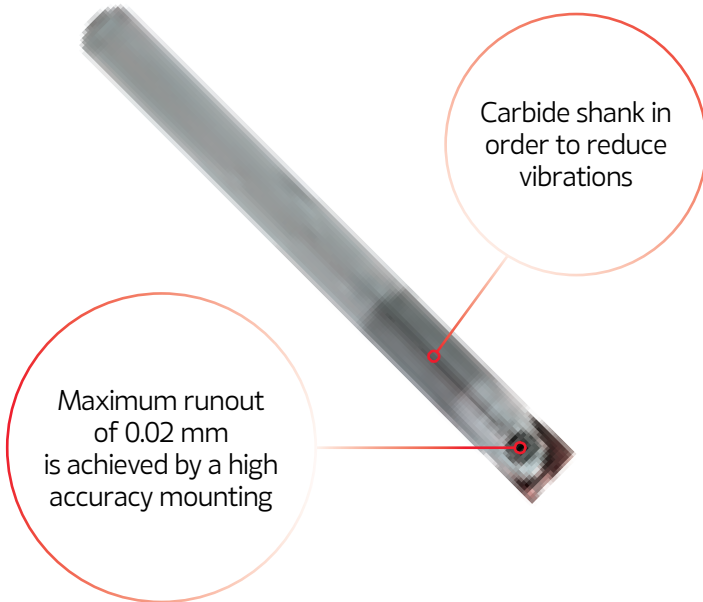

One toolholder for two types of inserts

PHH GRADE = PVD grade

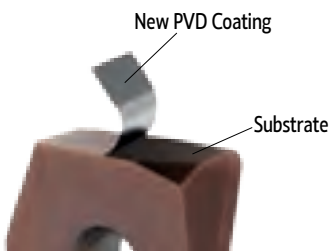

This new coating has a very high thermal stability and provides long tool life. For applications in machining of hardened steels, stainless steels and titanium alloys. This new coating achieves an unmatched balance between high hardness and thermal stability. It is the perfect coating for machining hardened material.

PHH603 NEW
H05-H15
P01-P05

Recommended for finishing operations in steels and hardened steels. First choice in mold and die finishing applications.









PHH910 NEW
P05-P10
H15-H30

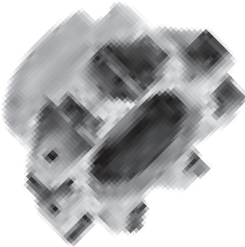
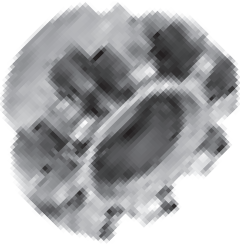
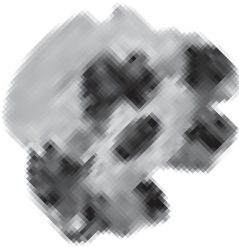

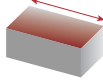
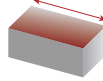
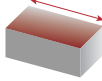
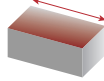

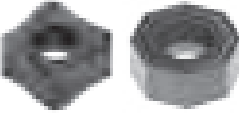



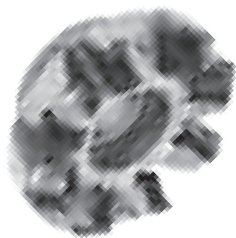
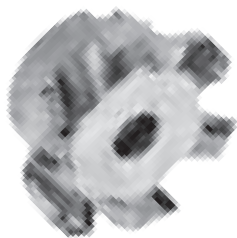

Recommended for finishing operations in steels and hardened steels in unstable conditions.

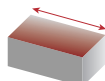
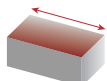
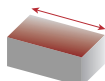
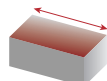
MILLING TOOLS OVERVIEW

A
 MILLING
 Overview
 Face milling
 Hi-feed milling
 Shoulder milling
 Profile milling
 Hardmill
 Center & Chamfer
 Spot face
 Spare Parts
 Technical Data
 End Mills

FACE MILLING CUTTERS

Program	PLUS 28088	PLUS 90260	PLUS 90845	PLUS 90945
	Proprietary milling line	Proprietary milling line	Proprietary milling line	Proprietary milling line
				
Material	P M K	P K	P M K N S	P M K N S
Main Operation	 Facing	 Facing	 Facing	 Facing
Kr°	88°	60°	45°	45°
Range (ØDc - mm)	50 - 200	50 - 160	32 - 250	50 - 250
	SN...1206...	PN...1105...	SN...1206... & ON...0505...	SN...1206...
Insert				
Couplings	Arbor mounting	Arbor mounting	Arbor mounting Weldon shank	Arbor mounting
Other Operations	 Shouldering		 Slanted Shoulder & Chamfer	 Slanted Shoulder & Chamfer
Page	56	60	64	68
Features	Indexable face mills with 8 helical cutting edges For rough to semi-finish with high-efficiency face milling Cutting edge angle enables performing face milling very close to the sidewall	Economical because double sided inserts applied 10 coners available improved insert design for distribution of cutting forces Excellent solution for cast iron	New line for Heavy and Soft face milling Two different geometries for same pocket Insert geometries available for all applications materials Excellent surface finishing	Economical because double sided inserts applied Variety of insert geometries is available for all applications materials Excellent surface finishing Available in regular and fine pitch cutters

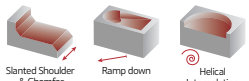
FACE MILLING CUTTERS				
Program	PLUS 91245	LINEPRO 06045	LINEPRO 09945	LINEPRO 00036
	Proprietary milling line 			
Material	P M K S	P M K N	P M K N	P K
Main Operation	 Facing	 Facing	 Facing	 Facing
Kr°	45°	45°	45°	36°
Range (ØDc - mm)	63 - 250	50 - 160	50 - 250	66 - 160
Insert	SN...1606... & ON...0606... 	SE...1204... 	SE...13T3... 	PD...1204... 
Couplings	Arbor mounting	Arbor mounting	Arbor mounting	Arbor mounting
Other Operations	 Slanted Shoulder & Chamfer	 Slanted Shoulder & Chamfer	 Slanted Shoulder & Chamfer	 Slanted Shoulder & Chamfer Ramp down Helical Interpolation
Page	72	76	78	82
Features	Two different geometries for same pocket Excellent surface finishing Available in regular and fine pitch cutters	Low cutting forces Good chip flow	Low cutting forces Suitable for high-speed machining Excellent chip flow High rigidity due to carbide shim	High rake angle and low cutting forces

A

MILLING

Overview

Face milling

Hi-feed milling

Shoulder milling

Profile milling

Hardmill

Center & Chamfer

Spot face





Spare Parts





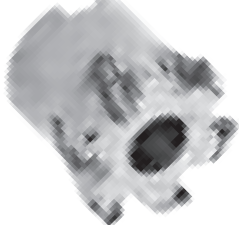
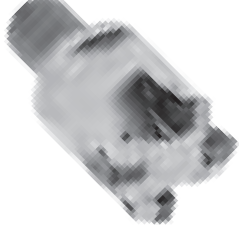
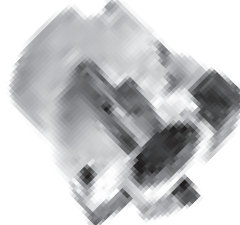
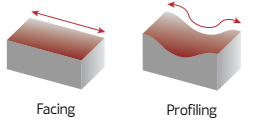
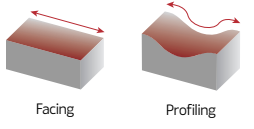
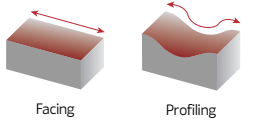
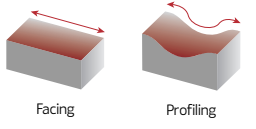

Technical Data

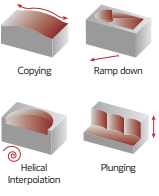
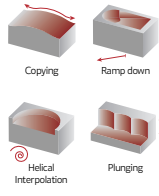
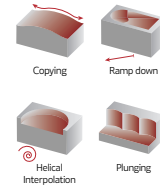
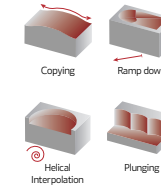
End Mills

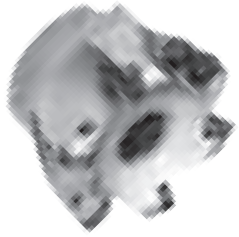
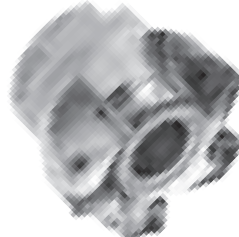
MILLING TOOLS OVERVIEW

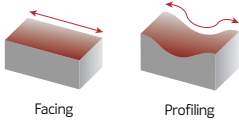
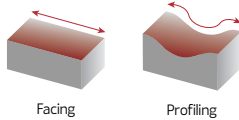
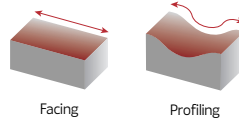
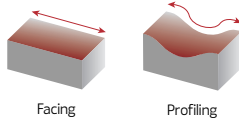



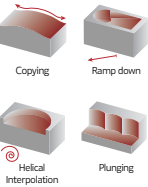
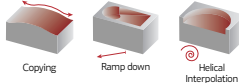
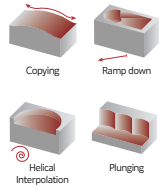
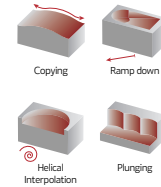



- A
- MILLING
- Overview
- Face milling
- Hifeed milling
- Shoulder milling
- Profile milling
- Hardmill
- Center & Chamfer
- Spot face
- Spare Parts
- Technical Data
- End Mills



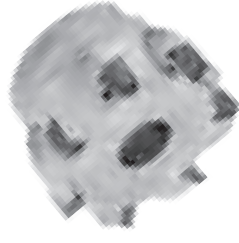
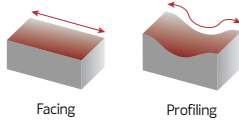
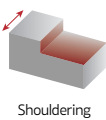
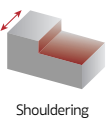
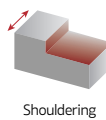
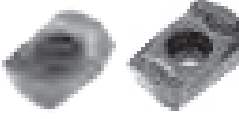

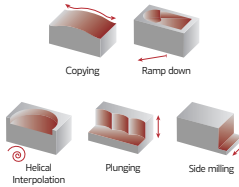
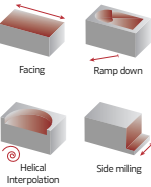

HIFEED MILLING CUTTERS				
Program	TETRAFEED 16320 <small>NEW</small>	PENTA HIFEED 06320	HIFEED 06410	HIFEED 06690
	Proprietary milling line 	Proprietary milling line 	Proprietary milling line 	Proprietary milling line 
Material	P M K S	P K	P M K S	P M K S
Main Operation	 Facing Profiling	 Facing Profiling	 Facing Profiling	 Facing Profiling
Kr°	20°	20°	10°	10°
Range (ØDc - mm)	16 - 63	20 - 66	20 - 42	32 - 100
	XNKU 06T3...	POKT 0403...	SO...0803...	SO...13M5...
Insert				
Couplings	Arbor mounting Weldon shank Threaded coupling	Arbor mounting Cylindrical shank Threaded coupling	Weldon shank Threaded coupling	Arbor mounting Threaded coupling
Other Operations	 Copying Ramp down Helical Interpolation Plunging	 Copying Ramp down Helical Interpolation Plunging	 Copying Ramp down Helical Interpolation Plunging	 Copying Ramp down Helical Interpolation Plunging
Page	84	88	92	98
Features	Double-sided insert with 4 cutting edges Optimized design for better chip evacuation High productivity	High feed cutting with low cutting load High productivity	High feed cutting with low cutting load High productivity	

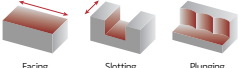
HIFEED MILLING CUTTERS				
Program	HIFEED 06815	HIFEED 50560	HIFEED 50060	HIFEED 06590
	Proprietary milling line			
				
Material	P M K S	P M K S	P K	P M K
Main Operation	 Facing Profiling	 Facing Profiling	 Facing Profiling	 Facing Profiling
Kr°	15°	-	-	10°
Range	63 - 160	52 - 80	35 - 80	20 - 42
Insert	SO...1605...	WD...1204...	WN...1207...	SP...08T3...
				
Couplings	Arbor mounting	Arbor mounting	Arbor mounting Threaded coupling	Weldon shank Threaded coupling
Other Operations				
Page	104	108	112	116
Features	High feed cutting with low cutting load High productivity	High feed cutting with low cutting load	High feed cutting with low cutting load Excellent in high overhang	High feed cutting with low cutting load

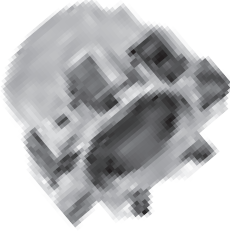
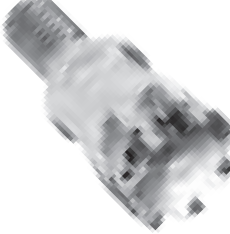
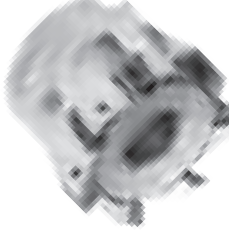
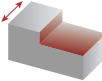
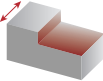
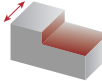
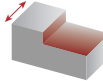
MILLING TOOLS OVERVIEW



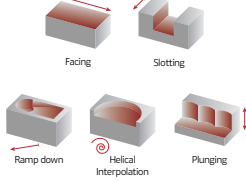
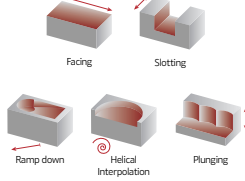

- A
- MILLING
- Overview
- Face milling
- Hifeed milling
- Shoulder milling
- Profile milling
- Hardmill
- Center & Chamfer
- Spot face
- Spare Parts
- Technical Data
- End Mills





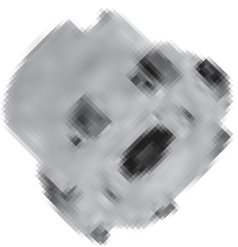
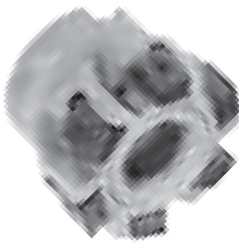
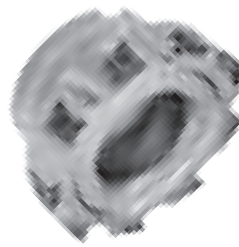
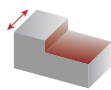
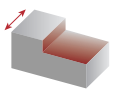
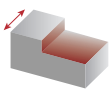
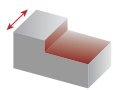

	HIFFED MILLING CUTTERS	SHOULDER MILLING CUTTERS		
Program	PRO 20090 20190	HEXAPLUS 49590 ^{NEW}	PLUS 49090	PLUS 17190
	Proprietary milling line 	Proprietary milling line 	Proprietary milling line 	Proprietary milling line 
Material	P M K S	P K	P K	P M K N S
Main Operation	 Facing Profiling	 Shouldering	 Shouldering	 Shouldering
Kr°	90°	90°	90°	90°
Range (ØDc - mm)	10 - 63	32 - 125	16 - 32	14 - 100
	XPET 0602... - HF XPET 1003... - HF	WNXT 0806...	WNHU 04T308-LP	ANHX 1004...
Insert				
Couplings	Arbor mounting Cylindrical shank Threaded coupling	Arbor mounting Weldon shank	Cylindrical shank Threaded coupling	Arbor mounting Weldon shank
Other Operations				
Page	138 144	120	124	126
Features	Chipbreaker HF for Hifeed machining	6 High rake cutting edges Excellent surface finish Strong insert seat	Economical because double sided inserts applied	4 corners insert with positive cutting edge Variety of insert geometries is available for all applications Helical cutting edge Available in regular and fine pitch cutters

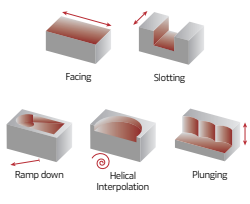
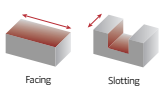
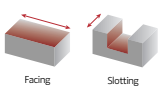
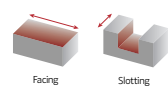
SHOULDER MILLING CUTTERS				
Program	PLUS 17590	PLUS 18190	LINEPRO 20090	LINEPRO 20190
	Proprietary milling line	Proprietary milling line	Proprietary milling line	Proprietary milling line
				
Material	P M K S	P K N	P M K N S H	P M K N S H
Main Operation	 Shouldering	 Shouldering	 Shouldering	 Shouldering
Kr°	90°	90°	90°	90°
Range (ØDc - mm)	25 - 125	32 - 160	10 - 32	16 - 63
	ANHX 1206...	ANHX 1607...	XP..0602...	XP...1003...
Insert				
Couplings	Arbor mounting Weldon shank Cylindrical shank Threaded coupling	Arbor mounting Weldon shank Threaded coupling	Cylindrical shank Threaded coupling	Arbor mounting Weldon shank Threaded coupling
Other Operations				
Page	130	134	138	144
Features	4 corners insert with positive cutting edge Variety of insert geometries is available for all applications Helical cutting edge Available in regular and fine pitch cutters	4 corners insert with positive cutting edge Variety of insert geometries is available for all applications Helical cutting edge Available in regular and fine pitch cutters	Excellent solution for square shoulder milling Offers longer tool life, better tolerances and better productivity parameters Low power requirement & smooth cutting possible due to positive helical angle Very flexible and suitable for most milling operations High positive cutting rake geometry	

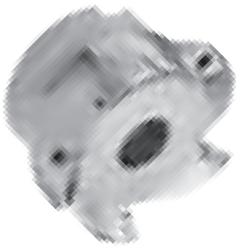
MILLING TOOLS OVERVIEW

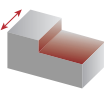
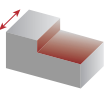
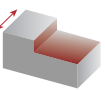

- A
- MILLING
- Overview
- Face milling
- Hi-feed milling
- Shoulder milling
- Profile milling
- Hardmill
- Center & Chamfer
- Spot face
- Spare Parts
- Technical Data
- End Mills

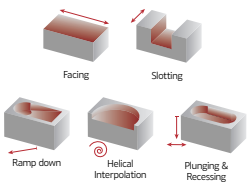
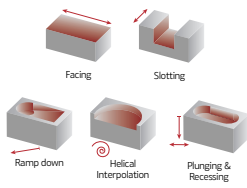
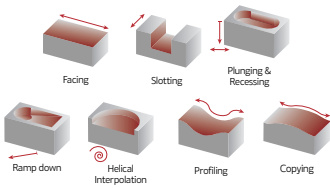

SHOULDER MILLING CUTTERS				
Program	LINEPRO 20290	TGPLUS 90090	TGPLUS 90190	TGPLUS 90390
	Proprietary milling line	Proprietary milling line	Proprietary milling line	Proprietary milling line
				
Material	P M K N S	P M K	P M K	P K
Main Operation	 Shouldering	 Shouldering	 Shouldering	 Shouldering
Kr°	90°	90°	90°	90°
Range (ØDc - mm)	32 - 125	16 - 63	25 - 125	50 - 160
	XP...1706...	LNXT 0904...	LNXT 1306...	LNXT 1506...
Insert				
Couplings	Arbor mounting Weldon shank	Arbor mounting Weldon shank Cylindrical shank Threaded coupling	Arbor mounting Cylindrical shank Weldon shank	Arbor mounting
Other Operations				
Page	152	156	160	164
Features	<p>Excellent solution for square shoulder milling</p> <p>Offers longer tool life, better tolerances and better productivity parameters</p> <p>Low power requirement & smooth cutting possible due to positive helical angle</p>	<p>Tangential inserts with 4 corners available</p> <p>High rake angle insert reduces cutting force</p> <p>Excellent insert rigidity and excellent machining stability</p> <p>Improved pocket configuration</p> <p>Available in regular and fine pitch cutters</p>		

SHOULDER MILLING CUTTERS			
Program	ALUPRO 76090	ALUPRO 77090	ALUPRO 08390
	<p>Proprietary milling line</p> 	<p>Proprietary milling line</p> 	
Material	N	N	N
Main Operation	 <p>Shouldering</p>	 <p>Shouldering</p>	 <p>Shouldering</p>
Kr°	90°	90°	90°
Range (ØDc - mm)	20 - 100	32 - 125	32
Insert	XDGX 15M5...	XDGX 22M7...	VCGX 2205...
			
Couplings	Arbor mounting Cylindrical shank	Arbor mounting Cylindrical shank	Threaded coupling
Other Operations			
Page	168	172	176
Features	<p>Solution for multi functional milling operations on aluminium alloys</p> <p>High speed conditions with high metal remove rate</p> <p>Stable clamping conditions (Anti-fly)</p> <p>High rake angle geometry that provides a good surface finish and low cutting forces</p>		<p>Excellent chip flow</p>

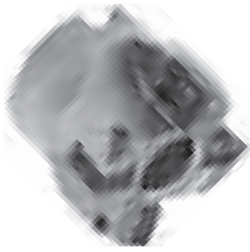
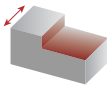
MILLING TOOLS OVERVIEW

- A
- MILLING
- Overview
- Face milling
- Hi-feed milling
- Shoulder milling
- Profile milling
- Hardmill
- Center & Chamfer
- Spot face
- Spare Parts
- Technical Data
- End Mills

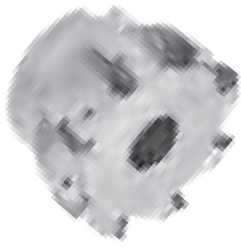
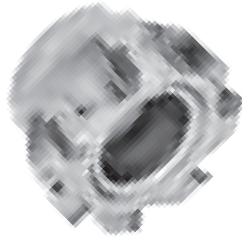
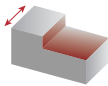
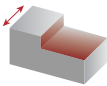
SHOULDER MILLING CUTTERS	
Program	LINEPRO 06290 NEW
	
Material	P M K S
Main Operation	 <p>Shouldering</p>
Kr°	90°
Range (ØDc - mm)	40 - 160
	SP...1204...
Insert	
Couplings	Arbor mounting
Other Operations	 <p>Facing</p>
Page	178
Features	<p>Positive inserts with 4 cutting edges</p> <p>Recommended for conventional milling machines and machining centers</p>

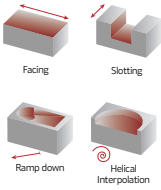
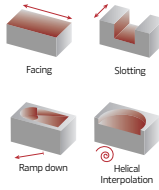
SHOULDER MILLING CUTTERS		
Program	LINEPRO 17090	LINEPRO 18090
		
Material	P M K N	P M K N
Main Operation	 Shouldering	 Shouldering
Kr°	90°	90°
Range (ØDc - mm)	16 - 63	25 - 125
Insert	AP...1003...	AP...1604...
		
Couplings	Arbor mounting Weldon shank Threaded coupling	Arbor mounting Weldon shank
Other Operations		
Page	180	186
Features	<p>Strong insert and low cutting force</p> <p>Helical cutting edge</p> <p>Good chip evacuation</p>	

A

MILLING

Overview

Face milling

Highfeed milling

Shoulder milling

Profile milling

Hardmill

Center & Chamfer

Spot face









Spare Parts

Technical Data

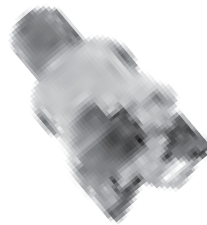
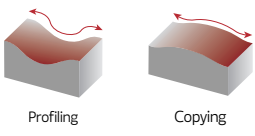
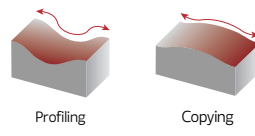
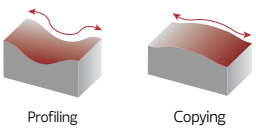
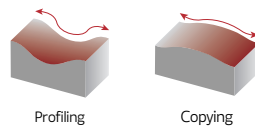
End Mills

MILLING TOOLS OVERVIEW

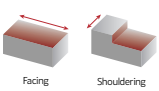
- A
- MILLING
- Overview
- Face milling
- Hi-feed milling
- Shoulder milling
- Profile milling
- Hardmill
- Center & Chamfer
- Spot face
- Spare Parts
- Technical Data
- End Mills







PROFILE MILLING CUTTERS						
Program	NEW	W-PRO 62090	NEW	BALLPRO 63090	PLUS 49095	PLUS 45095
		Proprietary milling line		Proprietary milling line	Proprietary milling line	Proprietary milling line
						
Material		P M K S H		P K	P K H	P K H
Main Operation						
Kr°		90°		-	95°	95°
Range (ØDc - mm)		8 - 20		32	16 - 35	25 - 42
		WCL... WCR...		XPGT 3206... DCMW 11T3...	WNHU 04T3...	WNHU 0604...
Insert						
Couplings		Cylindrical shank Threaded coupling		Threaded coupling	Threaded coupling	Threaded coupling
Other Operations				-		
Page		190		194	124	198
Features		Helical profile for smooth cutting Tight Insert tolerances Carbide shank to reduce vibrations		Designed for finishing and semi-finishing Strong insert design Stable cutting performance	Economical because double sided inserts applied Designed for finishing and profile milling Robust geometry	

PROFILE MILLING CUTTERS				
Program	TOROMILL 33590	TOROMILL 33690	TOROMILL 33790	TOROMILL 33890
	Proprietary milling line 	Proprietary milling line 	Proprietary milling line 	Proprietary milling line 
Material	P M S	P M S	P M S	P M S
Main Operation	 Profiling Copying	 Profiling Copying	 Profiling Copying	 Profiling Copying
Kr°	-	-	-	-
Range (ØDc - mm)	16 - 32	20 - 52	40 - 80	50 - 125
Insert	RDHT 0802... 	RPHT 10T3... 	RPHT 1204... 	RPHT 1605... 
Couplings	Cylindrical shank Threaded coupling	Arbor mounting Cylindrical shank Threaded coupling	Arbor mounting	Arbor mounting
Other Operations	 Facing Slotting Ramp down Helical Interpolation	 Facing Slotting Ramp down Helical Interpolation	 Facing Slotting Ramp down Helical Interpolation	 Facing Slotting Ramp down Helical Interpolation
Page	200	200	200	202
Features	<p>Excellent solution for Profile milling</p> <p>Low power requirement & smooth cutting possible due to positive helical angle</p> <p>First choice for problematic materials (M and S material classes)</p> <p>High positive cutting rake geometry</p>			

MILLING TOOLS OVERVIEW

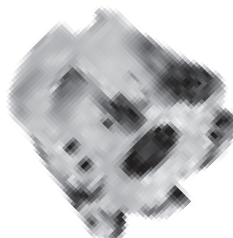
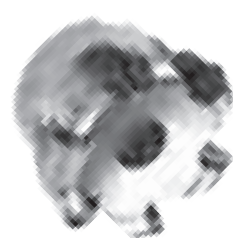
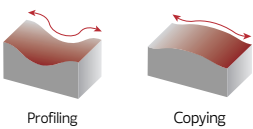
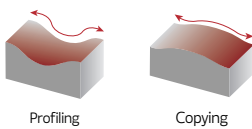
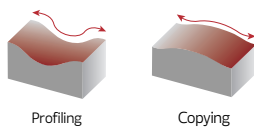
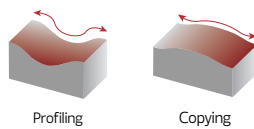
- A
- MILLING
- Overview
- Face milling
- Hi-feed milling
- Shoulder milling
- Profile milling
- Hardmill
- Center & Chamfer
- Spot face
- Spare Parts
- Technical Data
- End Mills

PROFILE MILLING CUTTERS				
Program	TOROMILL 33990	TURBOMILL 34190 <small>NEW</small>	TURBOMILL 34290 <small>NEW</small>	TOROMILL X2 35190
	Proprietary milling line 	Proprietary milling line 	Proprietary milling line 	Proprietary milling line 
Material	P M S	P M S	P M S	P M K S
Main Operation	 Profiling Copying	 Profiling Copying	 Profiling Copying	 Profiling Copying
Kr°	-	-	-	-
Range (ØDc - mm)	80 - 125	42 - 52	40 - 80	32 - 80
Insert	RPHT 2066... 	RPHT 10T3...-LS(4) 	RPHT 1204...-LS(4) 	RNHX 1204... 
Couplings	Arbor mounting	Arbor mounting	Arbor mounting	Arbor mounting Weldon shank Threaded coupling
Other Operations	 Facing Slotting Ramp down Helical Interpolation	 Facing Slotting Ramp down Helical Interpolation	 Facing Slotting Ramp down Helical Interpolation	 Facing Slotting Ramp down Helical Interpolation
Page	202	204	204	210
Features	Excellent solution for Profile milling Low power requirement & smooth cutting possible due to positive helical angle First choice for problematic materials (M and S material classes) High positive cutting rake geometry	Excellent solution for Profile milling First choice for problematic materials (M and S material classes) Improved insert seat	Excellent solution for Profile milling First choice for problematic materials (M and S material classes) Improved insert seat	Excellent solution for Profile milling "First choice for problematic materials (M and S material classes) High positive cutting rake geometry

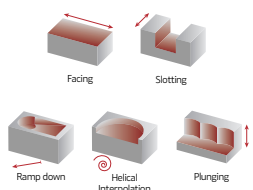
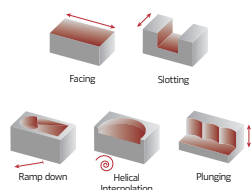
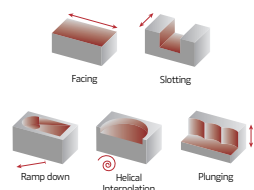



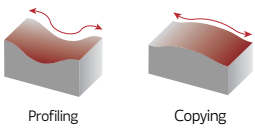
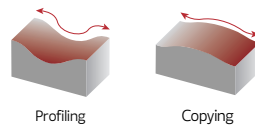
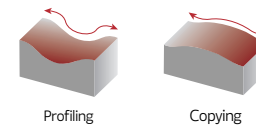
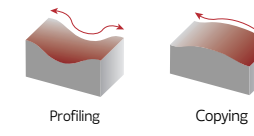
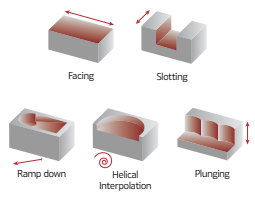
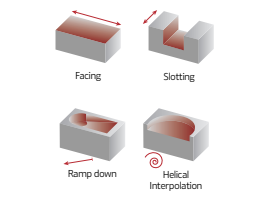
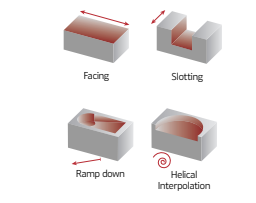
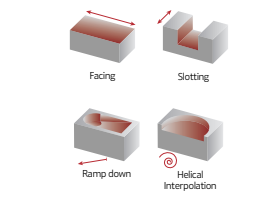

PROFILE MILLING CUTTERS				
Program	TOROMILL 24590	TOROMILL 25090	TOROMILL 25190	TOROMILL 25290
				
Material	P K H	P K H	P K H	P K H
Main Operation	 Profiling Copying	 Profiling Copying	 Profiling Copying	 Profiling Copying
Kr°	-	-	-	-
Range (ØDc - mm)	15 - 20	20 - 52	24 - 80	32 - 160
Insert	RD...0702...	RD...1003...	RD...12T3...	RD...1604...
				
Couplings	Weldon shank Threaded coupling	Arbor mounting Weldon shank Threaded coupling	Arbor mounting Weldon shank Threaded coupling	Arbor mounting Threaded coupling
Other Operations	 Facing Slotting Ramp down Helical Interpolation Plunging	 Facing Slotting Ramp down Helical Interpolation Plunging	 Facing Slotting Ramp down Helical Interpolation Plunging	 Facing Slotting Ramp down Helical Interpolation Plunging
Page	214	214	214	216
Features	<p>Offers longer tool life, better tolerances and better productivity parameters</p> <p>Low power requirement & smooth cutting possible due to positive helical angle</p> <p>Very flexible and suitable for most milling operations</p> <p>High positive cutting rake geometry</p>			

MILLING TOOLS OVERVIEW

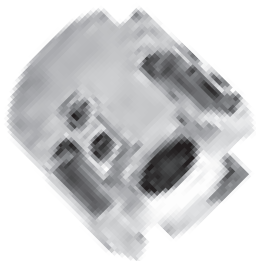
A
 MILLING
 Overview
 Face milling
 Hi-feed milling
 Shoulder milling
 Profile milling
 Hardmill
 Center & Chamfer
 Spot face
 Spare Parts
 Technical Data
 End Mills

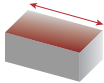
PROFILE MILLING CUTTERS

Program	TOROMILL 25390	LINEPRO 40095	LINEPRO 40595	LINEPRO 41095
Material	P K H	P K N H	P K N H	P K N H
Main Operation				
Kr°	-	95°	95°	95°
Range (ØDc - mm)	80 - 160	16 - 25	25 - 80	10 - 12
Insert	RD...2006...	XD...0602...	XD...10T3...	XD...0401...
Couplings	Arbor mounting	Threaded coupling	Arbor mounting Threaded coupling	Threaded coupling
Other Operations				
Page	216	222	222	222
Features	<p>Offers longer tool life, better tolerances and better productivity parameters</p> <p>Low power requirement & smooth cutting possible due to positive helical angle</p> <p>Very flexible and suitable for most milling operations</p> <p>High positive cutting rake geometry</p>	<p>Designed for finishing and profile milling</p> <p>Low power consumption</p>		

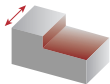
	HARDMILL	CENTER & CHAMFER	SPOT FACE
Program	HARDMILL 72090	CENTER & CHAMFER	SPOT FACE
			
Material	K N	P M K	P M K
	 Facing		
	90°		
Range (ØDc - mm)	40 - 160	13	10 - 21
	XNHW 1205...	SOMT SOGT 11T3...	SPKX 05... 06... 07... 09...
Insert			
Couplings	Arbor mounting	Weldon Shank	Weldon Shank Cylindrical shank
	 Shouldering	Spotting Chamfering Engraving Grooving Spot Drilling	Spot face
Page	226	230	232
Features	Excellent solution for aluminium PCD tip	Milling tool for a wide range of center & chamfer operations	Economical solution Smooth cutting

A

MILLING

Overview

Face milling

Hi-feed milling

Shoulder milling

Profile milling

Hardmill

Center & Chamfer

Spot face

Spare Parts

Technical Data

End Mills

MILLING INSERTS ISO IDENTIFICATION SYSTEM

A

MILLING

Overview

Face milling

Hifeed milling

Shoulder milling

Profile milling

Hardmill

Center & Chamfer

Spot face

Spare Parts

Technical Data

End Mills

H		M	
O		V	
P		W	
S		L	
T		A	
C		B	
D		K	
E		R	
F		X	Special

1- Insert shape symbol

Symbol	m (mm)	d (mm)	s (mm)
A	±0.005	±0.025	±0.025
F	±0.005	±0.013	±0.025
C	±0.013	±0.025	±0.025
H	±0.013	±0.013	±0.025
E	±0.025	±0.025	±0.025
G	±0.025	±0.025	±0.13
J	±0.005	±0.05~±0.13	±0.025
K*	±0.013	±0.05~±0.13	±0.025
L*	±0.025	±0.05~±0.13	±0.025
M*	±0.08~±0.20	±0.05~±0.13	±0.13
N*	±0.08~±0.20	±0.05~±0.13	±0.025
U*	±0.13~±0.38	±0.08~±0.25	±0.13

*As a rule, the sides of these inserts are as sintered. Tolerance differs with insert size, for the accuracy of class M, refer to the table on the right.

Triangular inserts with a facet (secondary cutting edge)

Detailed dimension of M class insert Insert height Tolerances (mm)					
Inscribed circle					
6.35	±0.08	-	-	-	-
9.525	±0.08	±0.08	±0.11	±0.10	±0.13
12.70	±0.13	±0.13	±0.13	±0.15	-
15.875	±0.15	±0.15	±0.15	±0.18	-
19.05	±0.15	±0.15	±0.15	±0.18	-
25.40	-	±0.18	-	-	-
31.75	-	±0.25	-	-	-

Inscribed circle Tolerances (mm)					
Inscribed circle					
6.35	±0.05	-	-	-	-
9.525	±0.05	±0.05	±0.05	±0.05	±0.05
12.70	±0.08	±0.08	±0.08	±0.08	±0.08
15.875	±0.10	±0.10	±0.10	±0.10	±0.10
19.05	-	-	-	-	±0.10
25.40	-	±0.13	-	-	±0.10
31.75	-	±0.20	-	-	±0.12

3 - Tolerances symbol

A	B	C	D	E
				Other clearance angle

2 - Normal clearance symbol

ISO | ANSI



4 - Insert symbol														
symbol	Type	Hole type	Chipbreaker	Shape	symbol	Type	Hole type	Chipbreaker	Shape	symbol	Type	Hole type	Chipbreaker	Shape
W	with hole	Round hole / one countersink (40°-60°)	Without chipbreaker		H	with hole	Round hole / one countersink (70°-90°)	Chipbreaker on one side		G	without hole	Round hole	Chipbreaker on both sides	
T			Chipbreaker on one side		C			Without chipbreaker		N			Without chipbreaker	
Q	with hole	Round hole / double countersink (40°-60°)	Without chipbreaker		J	with hole	Round hole / double countersink (70°-90°)	Chipbreaker on both sides		R	without hole	-	Chipbreaker on one side	
U			Chipbreaker on both sides		A			Without chipbreaker		F			Chipbreaker on both sides	
B	without hole	Round hole / one countersink (70°-90°)	Without chipbreaker		M	without hole	Round hole	Chipbreaker on one side		X	-	-	-	On request

R's	35° V's	55° D's	80° C's	90° S's	60° T's	80° W's	Ø CI		ANSI
							mm	inch	Symbol
-	06	04	-	03	06	02	3,97	5/32	1,20
-	08	05	04	04	08	L3	4,76	3/16	1,50
-	09	06	05	05	09	03	5,56	7/32	1,80
06**	-	-	-	-	-	-	6,00	0,236	
06*	11	07	06	06	11	04	6,35	1/4	2,00
07*	13	09	08	07	13	05	7,94	5/16	2,50
08*	-	-	-	-	-	-	8,00	0,315	
09*	16	11	09	09	16	06	9,525	3/8	3,00
10**	-	-	-	-	-	-	10,00	0,394	
12**	-	-	-	-	-	-	12,00	0,472	
12*	22	15	12	12	22	08	12,70	1/2	4,00
15*	27	19	16	15	27	10	15,875	5/8	5,00
16**	-	-	-	-	-	-	16,00	0,63	
19*	33	23	19	19	33	13	19,05	3/4	6,00
20**	-	-	-	-	-	-	20,00	0,787	
25**	-	-	-	-	-	-	25,00	0,984	
25*	44	31	25	25	44	17	25,40	1,00	8,00
31*	54	38	32	31	54	21	31,75	1 1/4	10,00
32**	-	-	-	-	-	-	32,00	1,26	

* ANSI designation only (Radius Designation is R00)
 ** Metric designation only (Radius Designation is M0)
 According to International Standard ISO 1832 - 2012(E)
 "Indexable inserts for cutting tools - Designation"

ISO	mm	ANSI	inch
01	1.59	1	0.062
T1	1.98	1.2	0.078
02	2.38	1.5	0.094
03	3.18	2	0.125
T3	3.97	2.5	0.156
04	4.76	3	0.188
05	5.56	3.5	0.219
06	6.35	4	0.250
07	7.94	5	0.312
09	9.52	6	0.375
12	12.70	8	0.500



10* - Chipbreaker geometries	
Cutting Condition	Main Application
1st letter	2nd letter
L - Light	P - Steel
M - Medium	M - Stainless Steel
H - Heavy	K - Cast Iron
W - Wiper	N - Aluminium
*only when required.	S - HRSA Titanium Alloys
	H - Hardened Materials

Ex.: ANHX160708PNER - MP

7* - Insert corner symbol			
ISO	mm	inch	ANSI
00	Sharp nose		0
01	0.10	.004	0.2
02	0.20	.008	0.5
04	0.40	.015	1
08	0.80	.032	2
12	1.2	.047	3
16	1.6	.062	4
20	2.0	.078	5
24	2.4	.094	6
28	2.8	.109	7
32	3.2	.125	8
00 (inch or M0/metric)	Round insert		0

*only when required.

7.1* - Insert edges symbol			
For inserts having secondary edges two digits are used:			
1st digit is secondary edge		2nd digit is secondary edges relief angle	
A	45°	A	3°
D	60°	B	5°
E	75°	C	7°
F	85°	D	15°
P	90°	E	20°
Z	special	F	25°
*only when required.		G	30°
		N	0°
		P	11°
		Z	special

8* - Cutting edge information		
Shape	Honing	Symbol
	No honing	F
	With honing	E
	Chamfered No honing	T
	Chamfered with honing	S

*only when required.

9 - Cutting direction		
Shape	Hand	Symbol
	Right	R
	Left	L
	None	N

A new step on coating innovation!

NEW



PHH603 NEW
H05-H15
P01-P05

Recommended for finishing operations in steels and hardened steels. First choice in mold and die finishing applications.

PHH910 NEW
P05-P10
H15-H30

Recommended for finishing operations in steels and hardened steels in unstable conditions.

PHH930 NEW
M20-M40
S20-S30

Recommended for general purpose milling of stainless steels and HRSA.

PHH530 NEW
M25-M40
S25-S35

Extremely heat resistant grade. First choice in hot-section turbine blade milling.

PHH808 NEW
M30-M40
S30-S40

High heat resistance grade. Economic choice in hot-section turbine blade milling.

A new step on coating innovation!

NEW



PHP910 NEW
P05-P10
K05-K10

Recommended for light operations in steels.

PHP920 NEW
P10-P35
K10-K30

Recommended for General Steel & Cast Iron Milling.

PHP930 NEW
P20-P40
K20-K40

Recommended for medium to roughing operations in steels and cast irons.

PHP530 NEW
P25-P40
M25-M40

Extremely heat resistant grade. First choice in cold-section turbine blade milling.

PHP808 NEW
P30-P40

High heat resistance grade. Economic choice for cold-section turbine blade milling.

PH

PH - Palbit Hardmetal
 PD - Palbit diamond
 PB - Palbit PCBN

X

Coating
 PCD | PCBN Grade

X

1 - Steel
 2 - Stainless steel
 3 - Cast Iron
 4 - Non Ferrous
 5 - Super Alloys
 6 - Hardened Materials
 7 - Wearparts
 9 - Universal Range

XX

01 - ISO Field
 (...)
 50 - ISO Field

A

MILLING

Overview

Face milling

Hi-feed milling

Shoulder milling

Profile milling

Hardmill

Center & Chamfer

Spot face

Spare Parts







Technical Data

End Mills





MILLING INSERTS OVERVIEW

A
 MILLING
 Overview
 Face milling
 Hifeed milling
 Shoulder milling
 Profile milling
 Hardmill
 Center & Chamfer
 Spot face
 Spare Parts
 Technical Data
 End Mills





FACE MILLING INSERTS

Reference	SNHU	SNKU	PNHX	PNKX	SNHX	SNKX
	Proprietary milling insert	Proprietary milling insert	Proprietary milling insert	Proprietary milling insert	Proprietary milling insert	Proprietary milling insert
						
Size	12	12	11	11	12 16	12 16
Material	P M K	P M K	P K	P K	P M K N S	P K
Page	56	56	61	61	65 69 73	65 69 73



HIFEED MILLING INSERTS

Reference	XNKU NEW	POKT	SOEW	SOET	WDET
	Proprietary milling insert	Proprietary milling insert	Proprietary milling insert		
					
Size	06	04	08 13 16	08 13 16	12
Material	P M K S	P K	P K	P M S	P M S
Page	85	89	93 99 104	93 99 104	109

SHOULDER MILLING INSERTS

Reference	WNXT NEW	WNHU	ANHX	XPET	XPHW
	Proprietary milling insert	Proprietary milling insert	Proprietary milling insert	Proprietary milling insert	Proprietary milling insert
					
Size	08	04	10 12 16	06 10 17	06 10
Material	P K	P K	P M K N S	P M K N S	P H
Page	121	196	126 132 135	139 147 153	139 147

SHOULDER MILLING INSERTS

Reference	APKT	APHT
		
Size	10 16	16
Material	P M K N	N
Page	181 187	187

FACE MILLING INSERTS						
Reference	ONHX	ONKX	SEHW	SEHT	PDMW	PDHW
	Proprietary milling insert 	Proprietary milling insert 				
Size	05 06	05 06	12 13	12 13	12	12
Material	P M K S	P M K S	P M K	P M K N	P	P K
Page	65 73	45 73	76 79	76 79	82	82

HIFED MILLING INSERTS					
Reference	WDMW	WNMW	SPKW	SPKT	XPET...HF
					Proprietary milling insert 
Size	12	12	08	08	06 10
Material	P K	P K	P K	P M K	P M K S
Page	109	113	117	117	139 147

SHOULDER MILLING INSERTS						
Reference	LNXT	XDGX	VCGX	SPGX ^{NEW}	SPMX ^{NEW}	APET
	Proprietary milling insert 					
Size	09 13 15	15 22	22	12	12	10
Material	P M K	N	N	P M K S	P M K S	N
Page	158 161 165	169 173	176	178	178	181

A

MILLING

Overview

Face milling

Hifed milling

Shoulder milling

Profile milling

Hardmill

Center & Chamfer

Spot face

Spare Parts

Technical Data

End Mills

MILLING INSERTS OVERVIEW

A

MILLING

Overview

Face milling

Hifeed milling

Shoulder milling

Profile milling

Hardmill

Center & Chamfer





Spot face

Spare Parts







Technical Data

End Mills

PROFILE MILLING INSERTS

Reference	WCR ^{NEW} Proprietary milling insert	WCL ^{NEW} Proprietary milling insert	WNHU Proprietary milling insert	RDHT Proprietary milling insert	RPHT Proprietary milling insert	RNHX Proprietary milling insert
						
Size	08 10 12 16 20	08 10 12 16 20	04 06	08	10 12 16 20	12
Material	P M K N S H	P M K N S H	P K H	P M S	P M S	P M K S
Page	191 192	191 192	125 196	203	203	211





PROFILE MILLING INSERTS

Reference	RDHT	RDHW	RDMT	RDMW	XDHW	XPGT ^{NEW} Proprietary milling insert
						
Size	10 12 16 20	07 10 12 16 20	10 12 20	10 12 16 20	04 06 10	32
Material	P K	P K H	P	P K	P K N H	P K
Page	217	217	217	217	223	194

HARDMILL MILLING INSERTS

CENTER & CHAMFER INSERTS

SPOT FACE

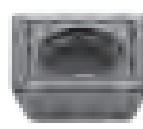
Reference	XNHW	XDHW	SOMT	SOGT ^{NEW}	SPKX
					
Size	12	04 06 10	11	11	05 06 07 09 11
Material	K N	N H	P M K	P M K	P M K S
Page	229	223	230	230	232

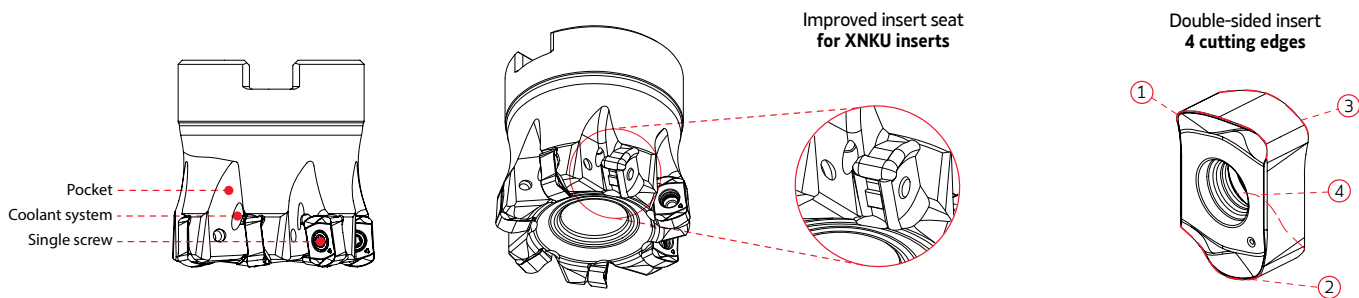

MILLING CUTTER

Design

- Optimized design for better chip evacuation;

Pocket

- Strong pocket design for better cutter body durability;
- Improved insert seat;

INSERT

Insert Width

- Large cross section;

Cutting edge

- Improved cutting edge;
- Improved wear resistance;

Double-sided insert

- Double-sided insert with 4 cutting edges;

XNKU 06T3

XNKU-MP

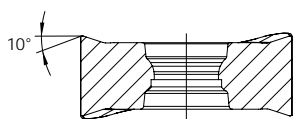











GEOMETRY FEATURES | Características geométricas | Características geométricas

Geometry	Features Características Características
Geometry MP General machining	Geometry with a reinforced cutting edge for general applications on different materials.

All information: Page - 84

MILLING INSERTS OVERVIEW

A	MILLING	Inserts Pastilhas Plaquitas	(1) Geometry code	(2) Grade code	P								M			K						N	
					PVD								PVD			CVD		PVD				UNC	UNC
					M6	54	68	66	78	86	15	68	66	15	L5	L9	D2	54	68	67	15	17	10
PH6103	PH6910	PH6920	PH6930	PH6125	PH6135	PH6740	PH6920	PH6930	PH6740	PH5705	PH5740	PH6705	PH6910	PH6920	PH6325	PH6740	PH0325	PH0910					
Overview		1111423	ACET 150612 TR																				
Face milling		1110014	APFT 1604 PDFR																				
		1110015	APFT 1604 PDSR																				
		1110557	APFT 1604 PDTR																				
Hi-feed milling		1110006	ADKT 1505 PDR																				
		1111218	ADKT 1505 PDSR																				
		1111209	ADKT 1505 PDTR																				
Shoulder milling		1112192	BOMT 130408R																				
Profile milling		1110038	BCKT 1304 PDR																				
Hardmill		1110922	HNGF 090520 - V																				
Center & Chamfer		1110957	HNGF 090520 - W																				

 First choice | Primeira opção | 1ª opção
  Stock item | Produto de stock | Itens de stock
  Available under request (see page A-9) | Disponível sobre consulta (consulte a página A-9) | Disponible bajo consulta (mire página A-9)
 Insert order code = (1) Geometry Code + (2) Grade Code

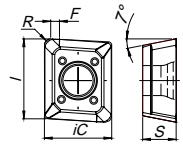
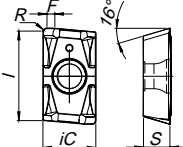
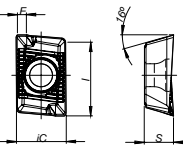
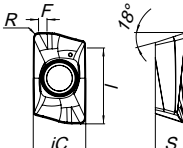
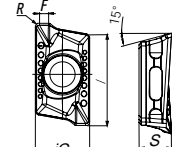
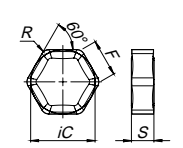
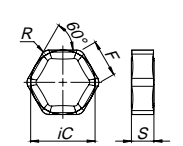
Dimensions (mm) Dimensões (mm) Dimensiones (mm)						Drawing
ic	S	I	R	a	F	
12,7	6,35	15,00	1,20	-	1,70	
9,53	4,76	16,00	0,80	-	2,00	
9,53	4,76	16,00	0,80	-	2,00	
9,53	4,76	16,00	0,80	-	2,00	
9,54	5,63	15,70	-	-	1,60	
9,54	5,63	15,70	-	-	1,60	
9,54	5,63	15,70	-	-	1,60	
8,13	4,85	11,50	1,20	-	1,40	
8,41	4,90	12,80	0,61	-	1,40	
16,20	5,56	9,16	2,00	-	-	
16,20	5,56	9,16	2,00	-	-	

MILLING INSERTS OVERVIEW

MILLING	A	Inserts Pastilhas Plaquetas	(1) Geometry code	(2) Grade code	P								M			K						N	
					PVD								PVD			CVD		PVD				UNC	UNC
					M6	54	68	66	78	86	15	68	66	15	L5	L9	D2	54	68	67	15	17	10
					PH6103	PH6910	PH6920	PH6930	PH6125	PH6135	PH6740	PH6920	PH6930	PH6740	PH5705	PH5740	PH6705	PH6910	PH6920	PH6325	PH6740	PH0325	PH0910
Overview		1111876	LNE 323-02													○							
		1111877	LNE 323-10														○						
Face milling		1110952	LNE 323-02 SP													○							
Hi-feed milling		1111420	LNE 434-02													○							
Shoulder milling		1111416	LN205 DDSR-A1													○							
Profile milling		1111518	OFEN 070405 TN		⊗	⊗					⊗				⊗	⊗		⊗					
Hardmill		1111569	OFKR 070408 FN-LN																⊗				
Center & Chamfer		1111568	OFKR 070408 SN-MP		⊗	⊗		⊗		⊗		⊗		⊗	⊗		⊗						
Spot face		1112133	RPEW 1204 M0			○					○					○							
Spare Parts		1121742	RPMT 1003 M0T			○										○							
		1120448	RPMT 1204 M0T			○										○							

First choice | Primeira opção | 1ª opción
 Stock item | Produto de stock | Itens de stock
 Available under request (see page A-9) | Disponível sobre consulta (consulte a página A-9) | Disponible bajo consulta (mire pagina A-9)
 Insert order code = (1) Geometry Code + (2) Grade Code

Dimensions (mm) Dimensões (mm) Dimensiones (mm)						Drawing
ic	S	L	R	a	F	
9,53	4,76	15,88	-	-	0,40	
9,53	4,76	15,88	1,27	-	-	
9,53	4,76	15,88	0,80	-	1,20	
14,28	6,35	19,05	-	-	0,80	
14,00	5,00	22,00	-	2,00	-	
18,00	4,76	7,40	0,60	-	2,20	
18,00	4,76	7,40	0,60	-	2,20	
18,00	4,76	7,40	0,60	-	1,60	
12,00	4,76	-	-	-	-	
10,00	3,18	-	-	-	-	
12,00	4,76	-	-	-	-	

A

MILLING

Overview

Face milling

Hi-feed milling

Shoulder milling

Profile milling

Hardmill

Center & Chamfer

Spot face

Spare Parts

Technical Data

End Mills

MILLING INSERTS OVERVIEW

A	MILLING	Inserts Pastilhas Plaquetas	(1) Geometry code	(2) Grade code	P								M			K					N	
					PVD								PVD			CVD	PVD					UNC
					M6	54	68	66	78	86	I5	68	66	I5	L9	D2	54	68	67	I5	17	10
PH6103	PH6910	PH6920	PH6930	PH6125	PH6135	PH6740	PH6920	PH6930	PH6740	PH5740	PH6705	PH6910	PH6920	PH6325	PH6740	PH0325	PH0910					
	1110200	SDHT 1204 AEEN																				
	1110693	SDHT 1204 AFFN																				
	1110201	SDHT 1204 AESN-PL																				
	1110818	SDHW 09T3 AEEN																				
	1110743	SDHW 09T3 AEFN																				
	1110781	SDHW 1204 AEEN																				
	1110782	SDHW 1204 AETN																				
	1112339	SDHW 150412																				
	1110206	SEAN 1203 AFEN																				
	1110207	SEAN 1203 AFFN																				
	1110208	SEAN 1203 AFSN																				
	1110209	SEAN 1203 AFTN																				
	1110211	SEAN 1504 AFFN																				
	1110212	SEAN 1504 AFTN																				
	1110224	SEHW 1504 AFSN																				
	1110225	SEHW 1504 AFTN																				
	1110226	SEKN 1203 AFEN																				
	1110227	SEKN 1203 AFFN																				
	1110228	SEKN 1203 AFSN																				
	1110230	SEKN 1203 AFTN																				
	1110794	SEKN 1204 AFFN																				
	1110232	SEKN 1204 AFSN																				
	1110233	SEKN 1204 AFTN																				
	1110235	SEKN 1504 AFEN																				
	1110238	SEKN 1504 AFTN																				
	1110239	SEKR 1203 AFEN																				
	1110240	SEKR 1203 AFSN																				
	1110241	SEKR 1204 AFSN																				
	1110759	SEKR 1504 AFSN																				
	1111921	SEXT 14M4 AGSN-M																				

First choice | Primeira opção | 1ª opción
 Stock item | Produto de stock | Itens de stock
 Available under request (see page A-9) | Disponível sobre consulta (consulte a página A-9) | Disponible bajo consulta (mire página A-9)
 Insert order code = (1) Geometry Code + (2) Grade Code

Dimensions (mm) Dimensões (mm) Dimensiones (mm)						Drawing
ic	S	I	R	a	F	
12,70	4,76	10,00	-	-	1,80	
12,70	4,76	10,00	-	-	1,80	
12,70	4,76	10,00	-	-	1,80	
9,53	3,97	7,30	0,30	-	1,50	
9,53	3,97	7,30	0,30	-	1,50	
12,70	4,76	9,00	-	-	2,50	
12,70	4,76	9,00	-	-	2,50	
15,88	4,76	-	1,20	-	-	
12,70	3,18	9,20	0,80	-	2,40	
12,70	3,18	9,20	0,80	-	2,40	
12,70	3,18	9,20	1,20	-	2,40	
12,70	3,18	9,20	1,20	-	2,40	
15,88	4,76	11,60	1,00	-	2,40	
15,88	4,76	11,60	1,00	-	2,40	
15,88	4,76	11,60	0,20	-	2,80	
15,88	4,76	11,60	0,20	-	2,80	
12,70	3,18	9,20	1,20	-	2,40	
12,70	3,18	9,20	1,20	-	2,40	
12,70	3,18	9,20	1,20	-	2,40	
12,70	3,18	9,20	1,20	-	2,40	
12,70	4,76	9,20	1,20	-	2,40	
12,70	4,76	9,20	1,20	-	2,40	
12,70	4,76	9,20	1,20	-	2,40	
15,88	4,76	12,30	1,00	-	2,40	
15,88	4,76	12,30	1,00	-	2,40	
12,70	3,18	9,20	1,20	-	2,40	
12,70	3,18	9,20	1,20	-	2,40	
12,70	4,76	9,20	1,20	-	2,40	
15,88	4,76	12,30	1,00	-	2,40	
14,00	4,00	9,20	1,00	-	2,80	

A

MILLING

Overview

Face milling

Hi-feed milling

Shoulder milling

Profile milling

Hardmill

Center & Chamfer

Spot face

Spare Parts

Technical Data

End Mills

MILLING INSERTS OVERVIEW

A
 MILLING
 Overview
 Face milling
 Hi-feed milling
 Shoulder milling
 Profile milling
 Hardmill
 Center & Chamfer
 Spot face
 Spare Parts
 Technical Data
 End Mills

Inserts Pastilhas Plaquitas	(1) Geometry code	(2) Grade code ISO Reference	P						M			K					N		
			PVD						PVD			CVD	PVD					UNC	UNC
			M6	54	68	66	78	86	I5	68	66	I5	L9	D2	54	68	67	I5	17
PH6103	PH6910	PH6920	PH6930	PH6125	PH6135	PH6740	PH6920	PH6930	PH6740	PH5740	PH6705	PH6910	PH6920	PH6325	PH6740	PH0325	PH0910		
	1110266	SNGN 120408			○														
	1110267	SNGN 120412			○														
	1110597	SNGN 190412			○														
	1110598	SNGN 190416			○														
	1110271	SNKN 1204 ENEN			⊗														
	1110273	SNKN 1204 ENSN			⊗														
	1120541	SNUN 120404			○														
	1120542	SNUN 120408			○														
	1120544	SNUN 120412			○														
	1121880	SNUN 190612T				○													
	1110765	SPGN 090312			○														
	1111173	SPGN 090316			○														
	1110300	SPGN 120308			○														
	1110301	SPGN 120312			○														
	1110303	SPGN 120408			○														
	1110588	SPGN 120412			○														
	1110590	SPGN 150408			○														
	1110304	SPGN 150412			○														
	1110326	SPKN 1203 EDFR																	
	1110328	SPKN 1203 EDSR			○		⊗	⊗											
	1110330	SPKN 1203 EDTR			⊗		⊗	⊗											
	1110331	SPKN 1204 EDER			⊗														
	1110332	SPKN 1204 EDSR			⊗				⊗										
	1110333	SPKN 1204 EDTR			○														
	1110336	SPKN 1504 EDER			⊗		⊗												
	1110337	SPKN 1504 EDFR			○														
	1110339	SPKN 1504 EDSR			⊗				⊗										
	1110340	SPKN 1504 EDTR			⊗		⊗		⊗										
	1110335	SPKN 1504 EDEL			○														
	1110338	SPKN 1504 EDSL			○														

Continue next page | Continua na próxima página | Sigue en la página siguiente

⊗ First choice | Primeira opção | 1ª opción
⊗ Stock item | Produto de stock | Itens de stock
○ Available under request (see page A-9) | Disponível sobre consulta (consulte a página A-9) | Disponible bajo consulta (mire página A-9)
Insert order code = (1) Geometry Code + (2) Grade Code

Dimensions (mm) Dimensões (mm) Dimensiones (mm)						Drawing
ic	S	l	R	a	F	
12,70	4,76	-	0,80	-	-	
12,70	4,76	-	1,20	-	-	
19,05	4,76	-	1,20	-	-	
19,05	4,76	-	1,60	-	-	
12,70	4,76	-	-	1,50	0,80	
12,70	4,76	-	-	1,50	0,80	
12,70	4,76	11,10	0,40	-	-	
12,70	4,76	11,10	0,80	-	-	
12,70	4,76	11,10	1,20	-	-	
19,05	6,35	-	1,20	-	-	
9,53	3,18	-	1,20	-	-	
9,53	3,18	-	1,60	-	-	
12,70	3,18	-	0,80	-	-	
12,70	3,18	-	1,20	-	-	
12,70	4,76	-	0,80	-	-	
12,70	4,76	-	1,20	-	-	
15,88	4,76	-	0,80	-	-	
15,88	4,76	-	1,20	-	-	
12,70	3,18	12,70	-	1,00	1,50	
12,70	3,18	12,70	-	1,00	1,50	
12,70	3,18	12,70	-	1,00	1,50	
12,70	4,76	12,70	-	1,00	1,50	
12,70	4,76	12,70	-	1,00	1,50	
12,70	4,76	12,70	-	1,00	1,50	
15,88	4,76	15,88	-	1,00	1,50	
15,88	4,76	15,88	-	1,00	1,50	
15,88	4,76	15,88	-	1,00	1,50	
15,88	4,76	15,88	-	1,00	1,50	
15,88	4,76	15,88	-	1,00	1,50	
15,88	4,76	15,88	-	1,00	1,50	

A

MILLING

Overview

Face milling

Hi-feed milling

Shoulder milling

Profile milling

Hardmill

Center & Chamfer

Spot face

Spare Parts

Technical Data

End Mills

MILLING INSERTS OVERVIEW

A MILLING			P					M			K					S					
	Inserts Pastilhas Plaquetas	(1) Geometry code	(2) Grade code ISO Reference	PVD					PVD			CVD		PVD			UNC	PVD			
				M6	54	68	66	86	15	68	66	15	L5	L9	D2	54	68	67	15	17	15
				PH6103	PH6910	PH6920	PH6930	PH6135	PH6740	PH6920	PH6930	PH6740	PH5705	PH5740	PH6705	PH6910	PH6920	PH6325	PH6740	PH0325	PH6740
	1111976	SPKR 1203 EDTR			○												○				
	1110564	SPKR 1504 EDFR			○												○				
	1111449	SPKR 1504 EDSR			○												○				
	1111107	SPKR 1906			○												○				
	1111195	SPKT 130510-E			⊗												⊗				
	1111153	SPKW 130510 F		○	○											○	○				
	1111355	SPKW 130510-E			⊗												⊗				
	1110888	SPKW 130510-S			⊗												⊗				
	1111609	SPMT 120408-MP			⊗						⊗						⊗	⊗	⊗		
	1120572	SPMW 120408			○						⊗						○	⊗			
	1191186	SPXN 1906			○		○	○							○		○				
	1112384	SPXN 1906-W			○												○				
	1112134	SPXR 1203 EDSR-MP			⊗												⊗	⊗			
	1110393	TNHF 1204 AN-CA										⊗	⊗	⊗	⊗	○					
	1111333	TNHF 1204 AN-K										⊗	⊗			⊗					

⊗ First choice | Primeira opção | 1ª opção
 ⊗ Stock item | Produto de stock | Itens de stock
 ○ Available under request (see page A-9) | Disponível sobre consulta (consulte a página A-9) | Disponible bajo consulta (mire página A-9)

Insert order code = (1) Geometry Code + (2) Grade Code

Dimensions (mm) Dimensões (mm) Dimensiones (mm)						Drawing
ic	S	I	R	a	F	
12,70	3,18	12,70	-	1,00	1,40	
15,88	4,76	15,88	-	1,00	1,40	
15,88	4,76	15,88	-	1,00	1,40	
19,05	6,35	19,05	-	1,00	1,40	
13,00	5,56	-	1,00	-	-	
13,00	5,56	-	1,00	-	-	
13,00	5,56	-	1,00	-	-	
13,00	5,56	-	1,00	-	-	
12,70	4,76	-	0,8	-	-	
12,70	4,76	-	0,8	-	-	
19,05	6,35	19,05	-	1,00	1,40	
19,05	6,35	-	-	-	12,00	
12,70	3,18	12,70	1,00	1,00	1,37	
12,70	4,76	12,00	2,00	-	1,70	
12,70	4,76	12,00	3,00	-	1,30	

A

MILLING

Overview

Face milling

Hi-feed milling

Shoulder milling

Profile milling

Hardmill

Center & Chamfer

Spot face

Spare Parts

Technical Data

End Mills

MILLING INSERTS OVERVIEW

A	MILLING	Inserts Pastilhas Plaquetas	(1) Geometry code	(2) Grade code	P						M			K							
					PVD						CVD		PVD			CVD		PVD			UNC
					54	68	G4	66	I5	G6	L8	L9	68	66	I5	L5	L9	54	68	67	I5
PH6910	PH6920	PH7920	PH6930	PH6740	PH7740	PH5125	PH5740	PH6920	PH6930	PH6740	PH5705	PH5740	PH6910	PH6920	PH6325	PH6740	PH0325				
Overview		1111911	TNUN 1204 ANEN		○																
Face milling		1110422	TPGN 110304		○																
		1110423	TPGN 110308		○																
		1110425	TPGN 160304		⊗																
		1110426	TPGN 160308		⊗																
Hi-feed milling		1110450	TPKN 1603 PDEL		○																
		1110451	TPKN 1603 PDER		⊗			⊗													
		1110671	TPKN 1603 PDSR		○																
		1110455	TPKN 1603 PDTR		⊗			⊗													
		1110459	TPKN 1603 PPFN		○																
		1110463	TPKN 1603 PPTR		○																
		1110465	TPKN 2204 PDER		⊗			⊗													
		1110466	TPKN 2204 PDFR		○																
		1110609	TPKN 2204 PDSR		⊗			⊗													
Shoulder milling		1110465	TPKN 2204 PDER		⊗			⊗													
		1110466	TPKN 2204 PDFR		○																
		1110609	TPKN 2204 PDSR		⊗			⊗													
		1110471	TPKN 2204 PPSR		○																
Profile milling		1110468	TPKN 2204 PDTR		○																
Hardmill		1110476	TPKR 1603 PDSR		⊗			⊗													
		1110477	TPKR 2204 PDSR		⊗			⊗													
Center & Chamfer		1120761	TPUN 110304		○																
		1120762	TPUN 110308		○																
		1120765	TPUN 160304			⊗			○	⊗	⊗										
		1120766	TPUN 160308			⊗			⊗	⊗	⊗										
		1120770	TPUN 160312		○				○	⊗	⊗										
		1120777	TPUN 220404		○				○	⊗	⊗										
		1120779	TPUN 220408		○				⊗	⊗	⊗										
		1120783	TPUN 220412		○				⊗	⊗	⊗										
		1120791	TPUN 270616						○												
Spotface																					
Spare Parts		1112135	TPXR 2204 PDSR-MP		⊗			⊗													

⊗ First choice | Primeira opção | 1ª opción
 ⊗ Stock item | Produto de stock | Itens de stock
 ○ Available under request (see page A-9) | Disponível sobre consulta (consulte a página A-9) | Disponible bajo consulta (mire página A-9)
 Insert order code = (1) Geometry Code + (2) Grade Code

Dimensions (mm) Dimensões (mm) Dimensiones (mm)						Drawing
ic	S	I	R	a	F	
12,70	4,76	12,00	-	-	2,50	
6,35	3,18	-	0,40	-	-	
6,35	3,18	-	0,40	-	-	
9,53	3,18	-	0,40	-	-	
9,53	3,18	-	0,80	-	-	
9,53	3,18	16,50	0,70	-	1,20	
9,53	3,18	16,50	0,70	-	1,40	
9,53	3,18	16,50	0,70	-	1,20	
9,53	3,18	16,50	0,70	-	1,40	
9,53	3,18	16,50	-	-	1,10	
9,53	3,18	16,50	-	-	1,10	
12,70	4,76	22,00	0,50	-	1,70	
12,70	4,76	22,00	0,50	-	1,70	
12,70	4,76	22,00	0,50	-	1,70	
12,70	4,76	22,00	-	-	1,40	
12,70	4,76	22,00	-	-	1,40	
9,53	3,18	16,50	0,60	-	1,20	
12,70	4,76	22,00	0,50	-	1,70	
6,35	3,18	11,00	0,40	-	-	
6,35	3,18	11,00	0,80	-	-	
9,53	3,18	16,50	0,40	-	-	
9,53	3,18	16,50	0,80	-	-	
9,53	3,18	16,50	1,20	-	-	
12,70	4,76	22,00	0,40	-	-	
12,70	4,76	22,00	0,80	-	-	
12,70	4,76	22,00	1,20	-	-	
15,88	6,35	27,00	1,60	-	-	
12,70	4,76	22,00	1,00	-	1,70	

A

MILLING

Overview

Face milling

Hi-feed milling

Shoulder milling

Profile milling

Hardmill

Center & Chamfer







Spot face

Spare Parts

Technical Data

End Mills

MILLING INSERTS OVERVIEW

A			P						M			K									
	Inserts Pastilhas Plaquetas	(1) Geometry code	(2) Grade code	PVD						PVD			CVD		PVD				UNC		
				M6	54	68	66	78	86	I5	68	66	I5	L5	L9	D2	54	68	67	I5	17
		ISO Reference	PH6103	PH6910	PH6920	PH6930	PH6125	PH6135	PH6740	PH6920	PH6930	PH6740	PH5705	PH5740	PH6705	PH6910	PH6920	PH6325	PH6740	PH0325	
Overview		1110851	WPB 08	○	○	○										○	○				
		1110852	WPB 10	○	○	○											○	○			
		1110853	WPB 12	○	○	○											○	○			
		1110923	WPB 16	○	○	○											○	○			
		1111019	WPB 20	○	○	○											○	○			
Face milling		1111554	WPRX-2 08		○	○										○	○				
		1111331	WPRX-2 10		⊗	⊗											⊗	⊗			
		1111555	WPRX-2 12		⊗	⊗											⊗	⊗			
		1111329	WPRX-2 16		⊗	⊗											⊗	⊗			
		1111330	WPRX-2 20		⊗	⊗											⊗	⊗			
		1111556	WPRX-2 25		⊗	⊗											⊗	⊗			
		1111557	WPRX-2 32		⊗	⊗											⊗	⊗			
Shoulder milling		1110820	WPV 08	○	○	○										○	○				
		1110821	WPV 10	○	○	○											○	○			
		1110822	WPV 12	○	○	○											○	○			
		1110948	WPV 16	○	○	○											○	○			
		1111020	WPV 20	○	○	○											○	○			
Profile milling		1110543	WPZ 08	⊗	○	○										○	○				
		1110551	WPZ 10	⊗	○	○											○	○			
		1110552	WPZ 12	⊗	○	○											○	○			
		1110544	WPZ 16	⊗	⊗	○											○	○			
		1110553	WPZ 20	⊗	⊗	○											○	○			
		1110661	WPZ 25	⊗	⊗	○											○	○			
		1110662	WPZ 32	⊗	⊗	○											○	○			
Center & Chamfer		1110910	XPHT 1604 PDTR			○												○			
		1111206	XPHT 160420 PPTR			○													○		
		1110926	XPHT 160432 PDSR			○													○		
Spotface		1110958	XPHT 160412-MR			○												○			

⊗ First choice | Primeira opção | 1ª opción
 ⊗ Stock item | Produto de stock | Itens de stock
 ○ Available under request (see page A-9) | Disponível sobre consulta (consulte a página A-9) | Disponible bajo consulta (mire página A-9)
 Insert order code = (1) Geometry Code + (2) Grade Code

Dimensions (mm) Dimensões (mm) Dimensiones (mm)						Drawing
ic	S	l	R	a	F	
8,00	2,00	9,50	0,60	4,00	-	
10,00	2,50	11,50	0,80	5,00	-	
12,00	2,50	14,00	1,00	6,00	-	
16,00	3,00	16,00	1,30	6,00	-	
20,00	3,00	20,00	1,60	6,00	-	
8,00	2,00	9,50	-	2,50	-	
10,00	2,50	11,50	-	5,00	-	
12,00	2,50	11,90	-	6,00	-	
16,00	3,00	13,90	-	6,00	-	
20,00	3,00	15,90	-	6,00	-	
25,00	4,00	21,30	-	9,00	-	
32,00	5,00	25,80	-	10,00	-	
8,00	2,00	9,50	0,60	4,00	-	
10,00	2,50	11,50	0,80	5,00	-	
12,00	2,50	14,00	1,00	6,00	-	
16,00	3,00	16,00	1,30	6,00	-	
20,00	3,00	20,00	1,60	6,00	-	
8,00	2,40	7,00	-	3,00	-	
10,00	2,60	8,50	-	3,50	-	
12,00	3,00	10,00	-	4,00	-	
16,00	4,00	12,00	-	4,00	-	
20,00	5,00	15,00	-	5,00	-	
25,00	6,00	18,50	-	6,00	-	
32,00	7,00	23,50	-	7,50	-	
9,53	4,75	16,00	1,20	-	1,70	
9,53	4,75	16,00	2,00	-	0,70	
9,53	4,75	16,00	3,20	-	-	
9,53	4,75	16,00	1,20	-	1,70	

A

MILLING

Overview

Face milling

Highfeed milling

Shoulder milling

Profile milling

Hardmill

Center & Chamfer

Spot face

Spare Parts

Technical Data

End Mills

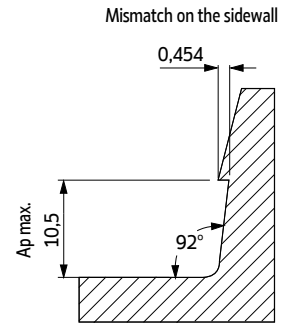
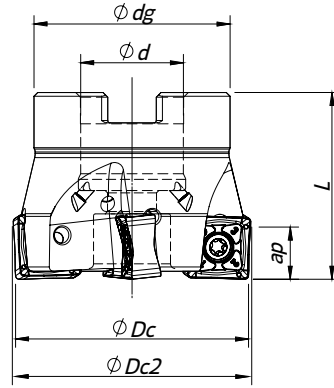
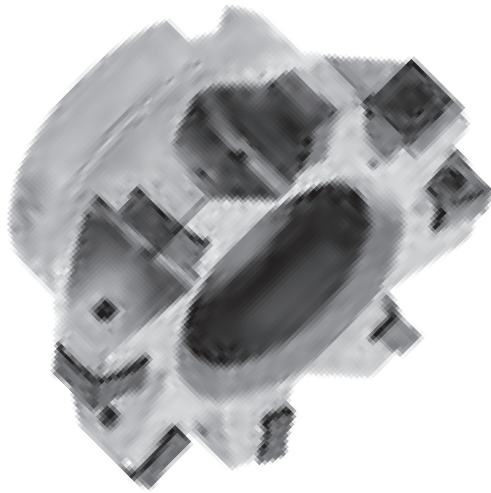

Arbor Mounting
 $K_r=88^\circ$ | $\gamma_p=-6^\circ$

Order code Código	Reference Referência Referencia		Dimensions Dimensões Dimensiones (mm)					Kg	Specifications		Insert Pastilha Inserto	Stock
			ϕDc	$\phi Dc2$	ϕd	ϕdg	L		Arbor Type	$Ap\ max$ (mm)		
181084300	050A28088-05-06-022040	5	50	50,9	22	42	40	0,4	A	10,5	SN... 1206...	
181091600	063A28088-06-06-022040	6	63	63,9	22	48	40	0,5	A	10,5	SN... 1206...	
181091700	080A28088-07-06-027050	7	80	80,9	27	60	50	1,0	A	10,5	SN... 1206...	
181091800	080A28088-09-06-027050	9	80	80,9	27	60	50	0,9	A	10,5	SN... 1206...	
181091900	100A28088-08-06-032050	8	100	100,9	32	73	50	1,6	B	10,5	SN... 1206...	
181092000	100A28088-11-06-032050	11	100	100,9	32	73	50	1,5	B	10,5	SN... 1206...	
181092100	125A28088-10-06-040063	10	125	125,9	40	90	63	3,1	B	10,5	SN... 1206...	
181092200	125A28088-14-06-040063	14	125	125,9	40	90	63	3,0	B	10,5	SN... 1206...	
181092300	160A28088-12-06-U040063	12	160	160,9	40	110	63	3,7	C	10,5	SN... 1206...	
181092700	160A28088-18-06-U040063	18	160	160,9	40	110	63	3,5	C	10,5	SN... 1206...	
181092800	200A28088-14-06-U060063	14	200	200,9	60	172	63	6,3	C	10,5	SN... 1206...	
181092900	200A28088-22-06-U060063	22	200	200,9	60	172	63	6,1	C	10,5	SN... 1206...	

Stock item | Produto de stock | Itens de stock

Available under request (see page A-9) | Disponível sobre consulta (consulte a página A-9) | Disponible bajo consulta (mire página A-9)

SPARE PARTS | Complementos | Repuestos

Cutter ϕDc	Insert Screw	Key (Torx)	Order separately		Order separately	
			Key (Torx - Nm)	Torque Value	Screw	DIN 6368 Wrench
A28088 - 50 - 80	P0401200	XT15	DT1530	3,0	-	-
A28088 - 100	P0401200	PT15	DT1530	3,0	J0164110	SD6368-16
A28088 - 125	P0401200	PT15	DT1530	3,0	J0204610	SD6368-20
A28088 - 160 - 200	P0401200	PT15	DT1530	3,0	-	-

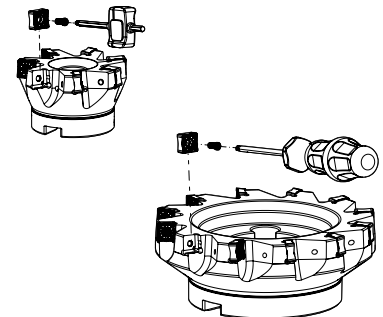

Note: The toolholder is supplied with the XT/PT key. To order the DT key please check the page A-241.
 Check the procedures for the clamping screws on the page A-241.

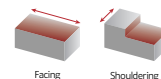

SNH(K)U 1206 | Inserts | Pastilhas | Plaquetas

SNHU-LP
(PHP grade)

SNKU-LP
(PHP grade)

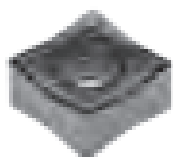
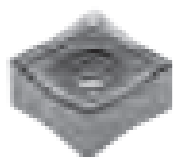

SNH(K)U-LP

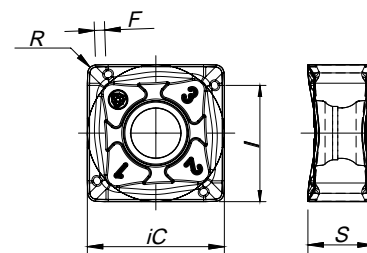

		P					M	K									Dimensions Dimensões Dimensiones (mm)				
		CVD		PVD			PVD		CVD			PVD									
(1) Geometry code	(2) Grade code	T9	G4	T1	P3	G6	G3	G6	L5	L6	L9	T9	G4	T1	P3	G6	iC	S	I	R	F
1112020	SNHU 120608 ZNER-LP	⊗	⊗	⊗	⊗	⊗	⊗	⊗	⊗	⊗	⊗	⊗	⊗	⊗	⊗	⊗	13,30	6,35	11,60	0,80	1,00
1112278	SNKU 120608 ZNER-LP	⊗	⊗	⊗	⊗	⊗	⊗	⊗	⊗	⊗	⊗	⊗	⊗	⊗	⊗	⊗	13,30	6,35	11,60	0,80	1,00

⊗ First choice | Primeira opção | 1ª opción ⊗ Stock item | Produto de stock | Itens de stock ○ Available under request (see page A-9) | Disponível sobre consulta (consulte a página A-9) | Disponible bajo consulta (mire página A-9) Insert order code = (1) Geometry Code + (2) Grade Code

GRADES SELECTION GUIDE | Guia para selecção de graus | Tabla para selección de calidades

ISO	PSM	Material	HB (Brinell)	Grades								
				← Wear Resistance				Toughness →				
				PH5705	PH5320	PHP920	PH7920	PH7930	PH5740	PH5740	PH7740	
P	1	Unalloyed Steel	125-220	⊗	⊗	⊗	⊗	⊗	⊗	⊗	⊗	⊗
	2	Low-Alloyed Steel	220-280	⊗	⊗	⊗	⊗	⊗	⊗	⊗	⊗	⊗
	3	High-Alloyed Steel	280-380	⊗	⊗	⊗	⊗	⊗	⊗	⊗	⊗	⊗
M	4	SS - Ferritic / Martensitic	200-330	⊗	⊗	⊗	⊗	⊗	⊗	⊗	⊗	⊗
	5	SS - Austenitic	200-330	⊗	⊗	⊗	⊗	⊗	⊗	⊗	⊗	⊗
	6	SS - Austenitic-ferritic (Duplex)	230-260	⊗	⊗	⊗	⊗	⊗	⊗	⊗	⊗	⊗
K	7	Malleable Cast Iron	130-230	⊗	⊗	⊗	⊗	⊗	⊗	⊗	⊗	⊗
	8	Grey Cast Iron	180-245	⊗	⊗	⊗	⊗	⊗	⊗	⊗	⊗	⊗
	9	Nodular Cast iron	160-250	⊗	⊗	⊗	⊗	⊗	⊗	⊗	⊗	⊗

⊗ Good Conditions
⊗ Average Conditions
⊗ Difficult Conditions

A
MILLING
Overview
Face milling
Hifed milling
Shoulder milling
Profile milling
Hardmill
Center & Chamfer
Spot face
Spare Parts
Technical Data
End Mills

PLUS 28088

RECOMMENDED CUTTING CONDITIONS | Condições de corte recomendadas | Condiciones de corte recomendables

ISO	PSM	Material	HB (Brinell)	V _c (m/min)			
				← Wear Resistance			
				PH5705	PH5320	PHP920	PH7920
P	1	Unalloyed Steel	125-220	-	-	180-250	180-240
	2	Low-Alloyed Steel	220-280	-	-	160-230	160-220
	3	High-Alloyed Steel	280-380	-	-	140-220	140-210
M	4	SS - Ferritic / Martensitic	200-330	-	-	-	-
	5	SS - Austenitic	200-330	-	-	-	-
	6	SS - Austenitic-ferritic (Duplex)	230-260	-	-	-	-
K	7	Malleable Cast Iron	130-230	160-290	150-280	160-270	160-260
	8	Grey Cast Iron	180-245	170-320	160-320	140-250	140-240
	9	Nodular Cast iron	160-250	140-200	100-190	120-210	120-200

(Note 1) The above table indicates the cutting conditions of 70% of the tool engagement.
 (Note 2) With low workspace clamping rigidity or long overhang of the tool, adjust cutting speed and feed to 70 or 80% of the recommended conditions above.
 (Note 3) Surface finishing is determined by speed/feed used.
 (Note 4) PH5... and PHS... can be used wet or dry. PH7... use only air.

Selection Example:

ISO	PSM	Material	HB (brinell)	V _c (m/min)		Feed f _z (mm/t)
				← Wear Resistance	Toughness →	
				PH5705	PH5740	SNHU 1206... SNKU 1206...
K	7	Malleable cast iron	130-230	160 (180) 290	160 (1900) 260	0,10 (0,25) 0,35
	8	Grey cast iron	180-245	170 (270) 320	140 (180) 240	0,10 (0,25) 0,35
	9	Nodular cast iron	160-250	140 (150) 200	120 (150) 200	0,10 (0,25) 0,35

This example shows the recommended starting cutting conditions, indicated in **Bold type**.

Vc (m/min)				Feed fz (mm/t)
PH7930	PH5740	PHS740	Toughness → PH7740	SNH(K)U 1206
160-220	-	140-220	140-200	0,10 (0,25) 0,35
140-200	-	120-200	130-180	0,10 (0,25) 0,35
120-190	-	100-190	100-170	0,10 (0,25) 0,35
140-200	-	-	130-180	0,10 (0,25) 0,35
120-160	-	-	110-160	0,10 (0,25) 0,35
100-140	-	-	90-150	0,10 (0,25) 0,35
150-240	160-260	-	140-220	0,10 (0,25) 0,35
140-230	140-240	-	120-210	0,10 (0,25) 0,35
100-190	120-200	-	100-190	0,10 (0,25) 0,35



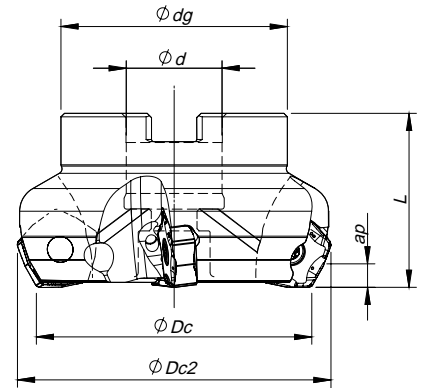
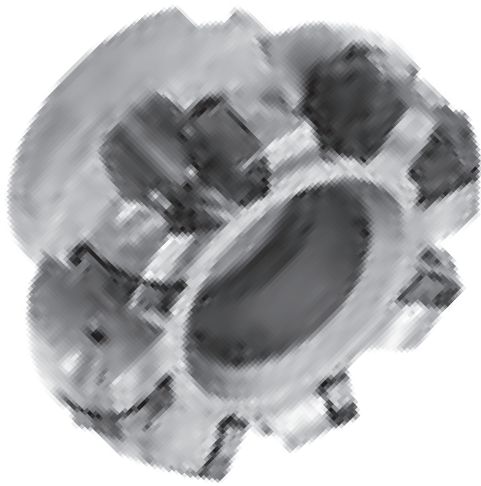

Arbor Mounting
 $K_r=60^\circ$ | $\gamma_p=7^\circ$

Order code Código	Reference Referência Referencia		Dimensions Dimensões Dimensiones (mm)					Kg	Specifications		Insert Pastilha Inserto	Stock
			ϕDc	$\phi Dc2$	ϕd	ϕdg	L		Arbor Type	Ap max (mm)		
181050200	050A90260-05-07-022040		50	59,05	22	48	40	0,388	A	5,0	PN... 1105...	
181050300	063A90260-06-07-022040		63	72,05	22	52	40	0,597	A	5,0	PN... 1105...	
181050400	080A90260-08-07-027050		80	89,05	27	60	50	1,072	B	5,0	PN... 1105...	
181045900	100A90260-10-07-032050		100	109,05	32	80	50	1,745	B	5,0	PN... 1105...	
181050500	125A90260-12-07-040063		125	134,05	40	90	63	3,047	B	5,0	PN... 1105...	
181050600	160A90260-14-07-U040063		160	169,05	40	110	63	4,397	C	5,0	PN... 1105...	

Stock item | Produto de stock | Itens de stock

Available under request (see page A-9) | Disponível sobre consulta (consulte a página A-9) | Disponible bajo consulta (mire pagina A-9)

SPARE PARTS | Complementos | Repuestos

Cutter ϕDc	Order separately				Order separately	
	Insert Screw	Key (Torx)	Key (Torx - Nm)	Torque Value	Screw	DIN 6368 Wrench
A90260 - 50 - 63				3,0	-	-
A90260 - 80				3,0	J0123510	SD6368-12
A90260 - 100				3,0	J0164110	SD6368-16
A90260 - 125				3,0	J0204610	SD6368-20
A90260 - 160				3,0	-	-

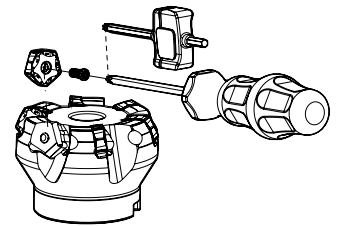

Note: The toolholder is supplied with the XT/PT key. To order the DT key please check the page A-241.
 Check the procedures for the clamping screws on the page A-241.



PNH(K)X 1105 | Inserts | Pastilhas | Plaquetas

PNHX-MK

PNHX-HK

PNKX-MK

PNH(K)X-MK | HK

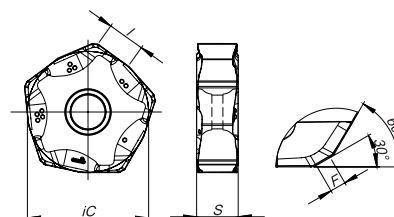

(1) Geometry code	(2) Grade code ISO Reference	P		K				Dimensions Dimensões Dimensiones (mm)				
		PVD		CVD		PVD		iC	S	I	R	F
		G1	G4	L5	L9	G1	G4					
		PH7910	PH7920	PH5705	PH5740	PH7910	PH7920					
1111374	PNHX 1105 ZNER-MK	☉	☉	☹	☉	☉	☉	16,50	5,66	5,70	-	1,30
1111998	PNHX 1105 ZNER-HK			☹	○			16,50	5,66	5,70	-	1,30
1112294	PNKX 1105 ZNER-MK	☉	☉	☹	○	☉	☉	16,50	5,66	5,70	-	1,30

☉ First choice | Primeira opção | 1ª opción ☉ Stock item | Produto de stock | Itens de stock ○ Available under request (see page A-9) | Disponível sobre consulta (consulte a página A-9) | Disponible bajo consulta (mire página A-9) Insert order code = (1) Geometry Code + (2) Grade Code

GRADES SELECTION GUIDE | Guia para selecção de graus | Tabla para selección de calidades

ISO	PSM	Material	HB (brinell)	Grades				
				← Wear Resistance			Toughness →	
				PH5705	PH7910	PH7920	PH5740	PH7740
P	1	Unalloyed Steel	125-220	●	●	●	●	●
	2	Low-Alloyed Steel	220-280		●	●		●
	3	High-Alloyed Steel	280-380		●	●		●
K	7	Malleable Cast Iron	130-230	●	●	●	●	
	8	Grey Cast Iron	180-245	●	●	●	●	
	9	Nodular Cast iron	160-250	●	●	●	●	

● Good Conditions
 ● Average Conditions
 ● Difficult Conditions

PLUS 90260

RECOMMENDED CUTTING CONDITIONS | Condições de corte recomendadas | Condiciones de corte recomendables

ISO	PSM	Material	HB (Brinell)	Vc (m/min)		
				← Wear Resistance		
				PH5705	PH7910	PH7920
P	1	Unalloyed Steel	125-220	-	180-250	180-240
	2	Low-Alloyed Steel	220-280	-	160-230	160-220
	3	High-Alloyed Steel	280-380	-	140-220	140-210
K	7	Malleable Cast Iron	130-230	160-290	180-300	160-260
	8	Grey Cast Iron	180-245	170-320	160-250	140-240
	9	Nodular Cast iron	160-250	140-200	150-200	120-200

(Note 1) Cutting conditions $a_e/DC=70\%$.

(Note 2) Cutting conditions should be adjusted according to the machine and work rigidity.

(Note 3) If chattering occurs, reduce a_p and V_c by 30% and keep the same f_z per tooth.

CHIP-BREAKER SELECTION GUIDE | Guia para aplicações do quebra- aparas | Guía para aplicación del rompevirutas

ISO	PSM	Material	HB (Brinell)	Chip-Breaker Application	
				1st choice	Difficult Operations
				P	1
2	Low-Alloyed Steel	220-280	PNH(K)X 11... MK		-
3	High-Alloyed Steel	280-380	PNH(K)X 11... MK		-
K	7	Malleable Cast Iron	130-230	PNH(K)X 11... MK	PNH(K)X 11... HK
	8	Grey Cast Iron	180-245	PNH(K)X 11... MK	PNH(K)X 11... HK
	9	Nodular Cast iron	160-250	PNH(K)X 11... MK	PNH(K)X 11... HK

Vc (m/min)	Toughness →	Feed fz (mm/t)
PH5740		PNH(K)X 1105...
-		0,15-0,30
-		0,15-0,30
-		0,15-0,25
160-260		0,12-0,35
140-240		0,12-0,35
120-200		0,12-0,30



A

MILLING

Overview

Face milling

Hifeed milling

Shoulder milling

Profile milling

Hardmill

Center & Chamfer

Spotface

Spare Parts

Technical Data

End Mills

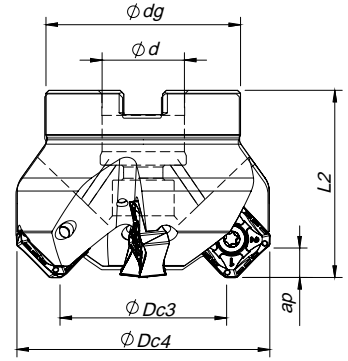
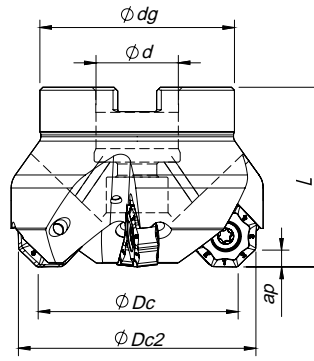
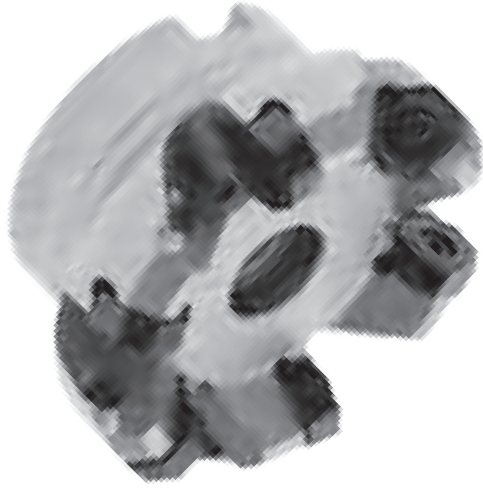

Arbor Mounting

$K_r=45^\circ$ | $\gamma_p=-6^\circ$

Order code Código	Reference Referência Referencia		Dimensions Dimensões Dimensiones (mm)							Kg	Specifications		Insert Pastilha Inserto	Stock	
			ϕDc	$\phi Dc2$	$\phi Dc3$	$\phi Dc4$	ϕd	ϕdg	L		L2	Arbor Type			Ap (mm)
181111400	050A90845-04-06-022040	4	50	57,6	47,1	62	22	48	40	41,5	0,383	A	3,5 6,0	ON...05 SN...12	
181117400	050A90845-06-06-022040	6	50	57,6	47,1	62	22	48	40	41,5	0,374	A	3,5 6,0	ON...05 SN...12	
181117500	063A90845-06-06-022040	6	63	70,6	60,1	75	22	52	40	41,5	0,525	A	3,5 6,0	ON...05 SN...12	
181117600	063A90845-08-06-022040	8	63	70,6	60,1	75	22	52	40	41,5	0,517	A	3,5 6,0	ON...05 SN...12	
181117700	080A90845-07-06-027050	7	80	87,6	77,1	92	27	60	50	51,5	0,846	B	3,5 6,0	ON...05 SN...12	
181117800	080A90845-10-06-027050	10	80	87,6	77,1	92	27	60	50	51,5	0,842	B	3,5 6,0	ON...05 SN...12	
181117900	100A90845-08-06-032050	8	100	107,6	97,1	112	32	80	50	51,5	1,559	B	3,5 6,0	ON...05 SN...12	
181120900	100A90845-12-06-032050	12	100	107,6	97,1	112	32	80	50	51,5	1,540	B	3,5 6,0	ON...05 SN...12	
181121000	125A90845-10-06-040063	10	125	132,6	122,1	137	40	90	63	64,5	2,890	B	3,5 6,0	ON...05 SN...12	
181121100	160A90845-12-06-U040063	12	160	167,6	157,1	172	40	110	63	64,5	4,360	C	3,5 6,0	ON...05 SN...12	
181121200	200A90845-14-06-U060063	14	200	207,6	197,1	212	60	172	63	64,5	8,890	C	3,5 6,0	ON...05 SN...12	
181121300	250A90845-16-06-U060063	16	250	257,6	247,1	262	60	172	63	64,5	11,490	C	3,5 6,0	ON...05 SN...12	

Stock item | Produto de stock | Itens de stock

Available under request (see page A-9) | Disponível sobre consulta (consulte a página A-9) | Disponible bajo consulta (mire página A-9)

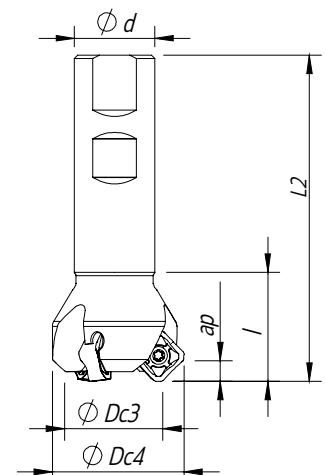
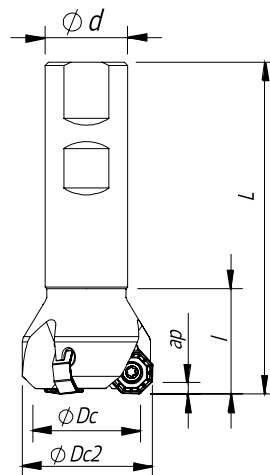

Weldon Shank

$K_r=45^\circ$ | $\gamma_p=-6^\circ$

Order code Código	Reference Referência Referencia		Dimensions Dimensões Dimensiones (mm)							Kg	Specifications		Insert Pastilha Inserto	Stock
			ϕDc	$\phi Dc2$	$\phi Dc3$	$\phi Dc4$	ϕd	L	L2		Ap (mm)			
181118000	032W90845-03-06-025100	3	32	39,6	29,1	44	25	100	101,5	0,375	3,5 6,0	ON...05 SN...12		
181118100	040W90845-04-06-032110	4	40	47,6	37,1	52	32	110	111,5	0,653	3,5 6,0	ON...05 SN...12		

Stock item | Produto de stock | Itens de stock

Available under request (see page A-9) | Disponível sobre consulta (consulte a página A-9) | Disponible bajo consulta (mire página A-9)

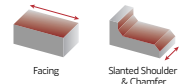

ONH(K)X 05 | SNH(K)X 12 | Inserts | Pastilhas | Plaquetas

A
MILLING
Overview
Face milling
Hifed milling
Shoulder milling
Profile milling
Hardmill
Center & Chamfer
Spot face
Spare Parts
Technical Data
End Mills

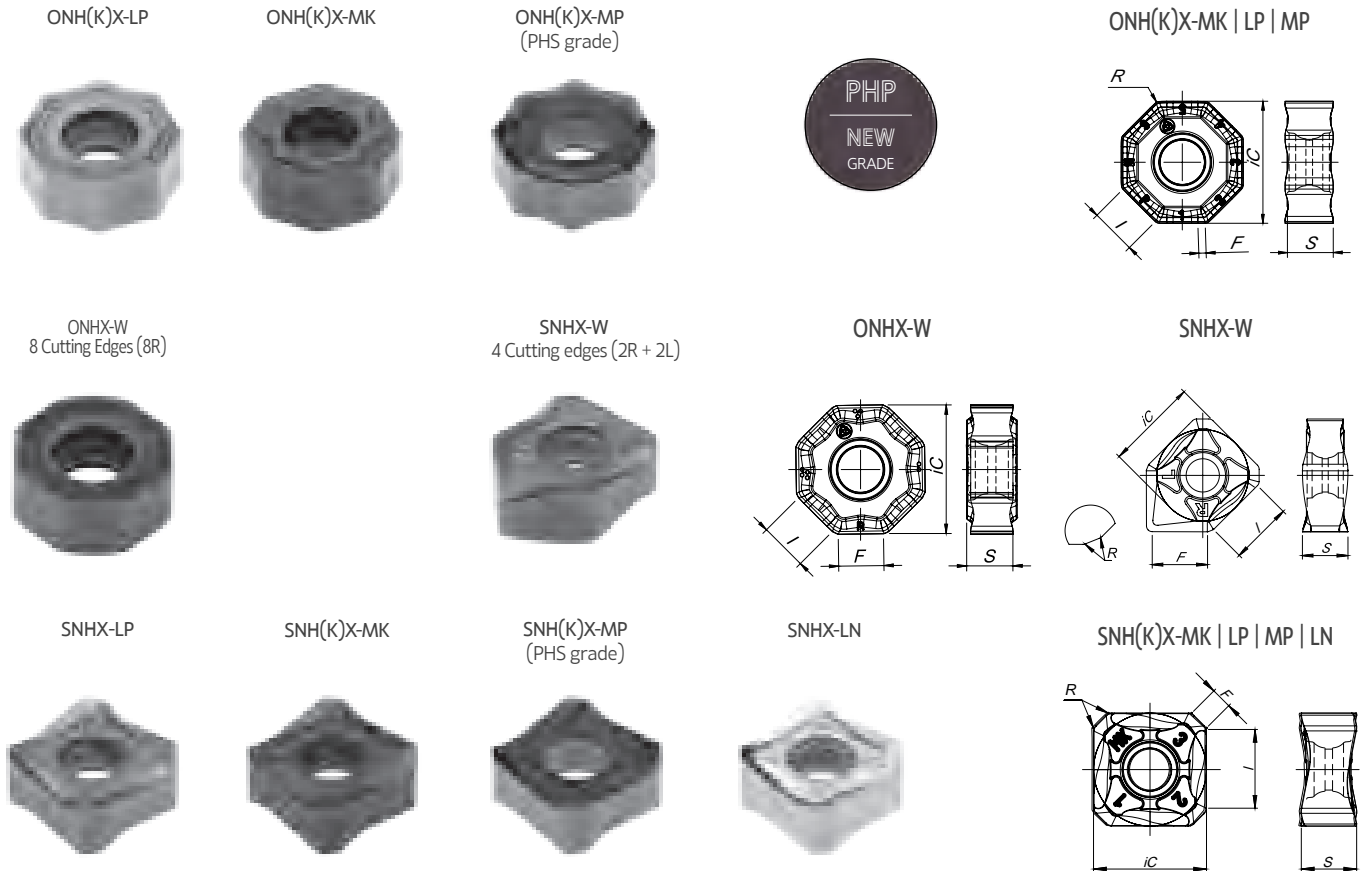

Geometry code	ISO Reference	P																		M		K						N		S		Dimensions Dimensões Dimensiones (mm)				
		CVD																		PVD		CVD			PVD			UNC		PVD		iC	S	I	R	F
		T9	X5	G4	T1	P3	P4	G6	X9	G6	L5	L6	L9	X5	G4	T1	P3	P4	G6	G6	10	X9	G6													
1112302	ONHX 050505 ANEN-LP				⊗		⊗	⊗		⊗					⊗		⊗	⊗				⊗	12,70	5,20	5,30	0,50	-									
1112304	ONHX 050505 ANSN-MP				⊗		⊗								⊗		⊗						12,70	5,20	5,30	0,50	-									
1112301	ONKX 050505 ANEN-LP			⊗	⊗	⊗	⊗		⊗						⊗	⊗	⊗	⊗			⊗		12,70	5,20	5,30	0,50	-									
1112303	ONKX 050505 ANSN-MP	⊗		⊗	⊗	⊗	⊗								⊗	⊗	⊗	⊗					12,70	5,20	5,30	0,50	-									
1112305	ONKX 050500 ANEN-MK														⊗	⊗							12,70	5,20	5,30	-	-									
1112307	ONHX 050500 ANER-W			⊗											⊗								12,70	5,20	5,30	-	4,30									
1111452	SNHX 1206 ANEN-LP				⊗		⊗		⊗							⊗		⊗			⊗		12,70	6,35	9,30	0,80	2,00									
1111502	SNHX 1206 ANSN-MP	⊗	⊗	⊗	⊗		⊗								⊗	⊗	⊗					12,70	6,35	9,30	0,80	2,00										
1111503	SNHX 1206 ANEN-MK														⊗	⊗	⊗	⊗					12,70	6,35	9,30	0,80	2,00									
1111504	SNHX 1206 ANFN-LN																				⊗		12,70	6,35	9,30	0,80	2,00									
1111899	SNHX 1206 ANFN-W*		⊗		⊗										⊗	⊗							12,70	6,30	9,30	0,40	7,60									
1112293	SNKX 1206 ANSN-MP	⊗		⊗	⊗		⊗								⊗	⊗				⊗			12,70	6,35	9,30	0,80	2,00									
1112249	SNKX 1206 ANEN-MK														⊗	⊗	⊗						12,70	6,35	9,30	0,80	2,00									

⊗ First choice | Primeira opção | 1ª opción ⊗ Stock item | Produto de stock | Itens de stock ○ Available under request (see page A-9) | Disponível sobre consulta (consulte a página A-9) | Disponible bajo consulta (mire página A-9) Insert order code = (1) Geometry Code + (2) Grade Code

* Wiper insert with 2 rights and 2 left-hand cutting edges.

PLUS 90845

SPARE PARTS | Complementos | Repuestos

Cutter ØDc	Insert Screw	Order separately			Order separately	
		Key (Torx)	Key (Torx - Nm)	Torque Value	Screw	DIN 6368 Wrench
A90845 - 50 - 63	P0401200	XT15	DT1530	3,0	-	-
A90845 - 80	P0401200	XT15	DT1530	3,0	J0123510	SD6368-12
A90845 - 100	P0401200	PT15	DT1530	3,0	J0164110	SD6368-16
A90845 - 125	P0401200	PT15	DT1530	3,0	J0204610	SD6368-20
A90845 - 160 - 250	P0401200	PT15	DT1530	3,0	-	-
W90845 - 32 - 40	P0401200	XT15	DT1530	3,0	-	-

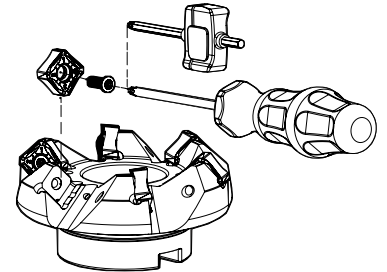

Note: The toolholder is supplied with the XT/PT key. To order the DT key please check the page A-241.
Check the procedures for the clamping screws on the page A-241.

GRADES SELECTION GUIDE | Guia para selecção de graus | Tabla para selección de calidades

ISO	PSM	Material	HB (Brinell)	Grades											
				← Wear Resistance								Toughness →			
				PH0910	PH5705	PH5320	PHP910	PHP920	PH7920	PHP930	PHH930	PH7930	PH5740	PHS740	PH7740
P	1	Unalloyed Steel	125-220				✓	✓	✓	✓		✓	✓		
	2	Low-Alloyed Steel	220-280				✓	✓	✓	✓		✓	✓		
	3	High-Alloyed Steel	280-380				✓	✓	✓	✓		✓	✓		
M	4	SS - Ferritic / Martensitic	200-330								✓	✓	✓		
	5	SS - Austenitic	200-330								✓	✓	✓		
	6	SS - Austenitic-ferritic (Duplex)	230-260								✓	✓	✓		
K	7	Malleable Cast Iron	130-230		✓	✓	✓	✓	✓	✓		✓	✓		
	8	Grey Cast Iron	180-245		✓	✓	✓	✓	✓	✓		✓	✓		
	9	Nodular Cast iron	160-250		✓	✓	✓	✓	✓	✓		✓	✓		
N	10	Aluminium and Non Ferrous	30-130	✓											
S	11	Heat Resistant Super Alloys	200-320								✓	✓	✓		

● Good Conditions

● Average Conditions

● Difficult Conditions

RECOMMENDED CUTTING CONDITIONS | Condições de corte recomendadas | Condiciones de corte recomendables

ISO	PSM	Material	HB (Brinell)	Vc (m/min)						
				← Wear Resistance				Toughness →		
				PH0910	PH5705	PH5320	PHP910	PHP920	PH7920	PHP930
P	1	Unalloyed Steel	125-220	-	-	-	180-250	180-250	180-240	160-220
	2	Low-Alloyed Steel	220-280	-	-	-	160-240	160-230	160-220	140-200
	3	High-Alloyed Steel	280-380	-	-	-	140-230	140-220	140-210	120-190
M	4	SS - Ferritic / Martensitic	200-330	-	-	-	-	-	140-220	140-200
	5	SS - Austenitic	200-330	-	-	-	-	-	130-180	120-160
	6	SS - Austenitic-ferritic (Duplex)	230-260	-	-	-	-	-	120-160	100-140
K	7	Malleable Cast Iron	130-230	-	160-290	150-280	180-300	160-270	160-260	150-240
	8	Grey Cast Iron	180-245	-	170-320	160-320	160-250	140-250	140-240	140-230
	9	Nodular Cast iron	160-250	-	140-200	100-190	150-210	120-210	120-200	100-190
N	10	Aluminium and Non Ferrous	30-130	100-2000	-	-	-	-	-	-
S	11	Heat Resistant Super Alloys	200-320	-	-	-	-	-	-	30-100

ISO	PSM	Material	HB (Brinell)	Vc (m/min)					Feed fz (mm/t)	
				← Wear Resistance			Toughness →		SNH(K)X 12...	ONH(K)X 05...
				PHH930	PH7930	PH5740	PH5740	PH7740		
P	1	Unalloyed Steel	125-220	-	160-220	-	140-220	140-200	0,10-0,35	0,10-0,35
	2	Low-Alloyed Steel	220-280	-	140-200	-	120-200	130-180	0,10-0,35	0,10-0,35
	3	High-Alloyed Steel	280-380	-	120-190	-	100-190	100-170	0,10-0,30	0,10-0,30
M	4	SS - Ferritic / Martensitic	200-330	140-210	140-200	-	-	130-180	0,10-0,30	0,10-0,30
	5	SS - Austenitic	200-330	120-170	120-160	-	-	110-160	0,10-0,30	0,10-0,30
	6	SS - Austenitic-ferritic (Duplex)	230-260	100-150	100-140	-	-	90-150	0,10-0,25	0,10-0,25
K	7	Malleable Cast Iron	130-230	-	150-240	160-260	-	140-220	0,10-0,35	0,10-0,35
	8	Grey Cast Iron	180-245	-	140-230	140-240	-	120-210	0,10-0,35	0,10-0,35
	9	Nodular Cast iron	160-250	-	100-190	120-200	-	100-190	0,10-0,30	0,10-0,30
N	10	Aluminium and Non Ferrous	30-130	-	-	-	-	0,10-0,35	-	
S	11	Heat Resistant Super Alloys	200-320	30-110	30-100	-	-	30-100	0,07-0,20	0,07-0,18

(Note 1) Cutting conditions $a_e/D_c=70\%$.

(Note 2) It's possible to occur vibrations in certain cases. Please reduce depth of cut and / or reduce cutting conditions in following cases:

- When using long shank;
- When using long tool overhang with arbor type;
- When application has poor clamping rigidity or when using a low rigidity machine.

(Note 3) PH5... and PHS... can be used wet or dry. PH7... use only air.

CHIP-BREAKER SELECTION GUIDE | Guia para aplicações do quebra- aparas | Guía para aplicación del rompevirutas

ISO	PSM	Material	HB (Brinell)	Chip-Breaker Application	
				1st choice	Difficult Operations
P	1	Unalloyed Steel	125-220	LP	MP
	2	Low-Alloyed Steel	220-280	LP	MP
	3	High-Alloyed Steel	280-380	MP	-
M	4	SS - Ferritic / Martensitic	200-330	LP	MP
	5	SS - Austenitic	200-330	LP	-
	6	SS - Austenitic-ferritic (Duplex)	230-260	LP	-
K	7	Malleable Cast Iron	130-230	MK	-
	8	Grey Cast Iron	180-245	MK	-
	9	Nodular Cast iron	160-250	MK	-
N	10	Aluminium and Non Ferrous	30-130	LN	-
S	11	Heat Resistant Super Alloys	200-320	LP	-



A

MILLING

Overview

Face milling

Hi-feed milling

Shoulder milling

Profile milling

Hardmill

Center & Chamfer

Spotface

Spare Parts

Technical Data

End Mills

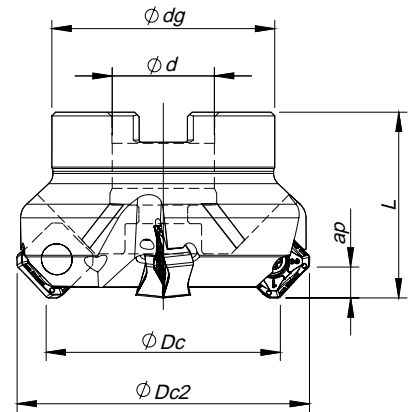

Arbor Mounting

$K_r=45^\circ$ | $\gamma_p=-6^\circ$

Order code Código	Reference Referência Referencia		Dimensions Dimensões Dimensiones (mm)					Kg	Specifications		Insert Pastilha Inserto	Stock
			ϕDc	$\phi Dc2$	ϕd	ϕdg	L		Arbor Type	A_p max (mm)		
181048200	050A90945-04-06-022040	4	50	63	22	48	40	0,424	A	6,0	SN... 1206	
181067000	050A90945-06-06-022040	6	50	63	22	48	40	0,415	A	6,0	SN... 1206	
181048300	063A90945-06-06-022040	6	63	76	22	52	40	0,575	A	6,0	SN... 1206	
181067100	063A90945-08-06-022040	8	63	76	22	52	40	0,577	A	6,0	SN... 1206	
181048400	080A90945-07-06-027050	7	80	93	27	60	50	0,966	B	6,0	SN... 1206	
181067200	080A90945-10-06-027050	10	80	93	27	60	50	0,950	B	6,0	SN... 1206	
181048500	100A90945-08-06-032050	8	100	113	32	80	50	1,667	B	6,0	SN... 1206	
181067300	100A90945-12-06-032050	12	100	113	32	80	50	1,650	B	6,0	SN... 1206	
181048600	125A90945-10-06-040063	10	125	138	40	90	63	2,890	B	6,0	SN... 1206	
181048700	160A90945-12-06-U040063	12	160	173	40	110	63	4,360	C	6,0	SN... 1206	
181052800	200A90945-14-06-U060063	14	200	213	60	172	63	8,890	C	6,0	SN... 1206	
181064700	250A90945-16-06-U060063	16	250	263	60	172	63	11,490	C	6,0	SN... 1206	

Stock item | Produto de stock | Itens de stock

Available under request (see page A-9) | Disponível sobre consulta (consulte a página A-9) | Disponible bajo consulta (mire página A-9)

SPARE PARTS | Complementos | Repuestos

Cutter ϕDc	Insert Screw	Key (Torx)	Order separately		Order separately	
			Key (Torx - Nm)	Torque Value	Screw	DIN 6368 Wrench
A90945 - 50 - 63	P0401200	XT15	DT1530	3,0	-	-
A90945 - 80	P0401200	XT15	DT1530	3,0	J0123510	SD6368-12
A90945 - 100	P0401200	PT15	DT1530	3,0	J0164110	SD6368-16
A90945 - 125	P0401200	PT15	DT1530	3,0	J0204610	SD6368-20
A90945 - 160 - 250	P0401200	PT15	DT1530	3,0	-	-

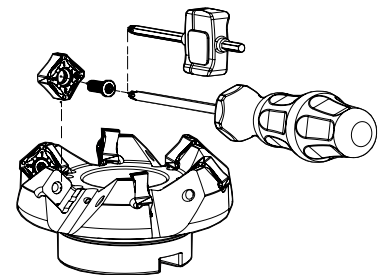

Note: The toolholder is supplied with the XT/PT key. To order the DT key please check the page A-241.
Check the procedures for the clamping screws on the page A-241.

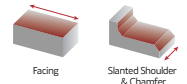

SNH(K)X 1206 | Inserts | Pastilhas | Plaquetas

SNHX-LP

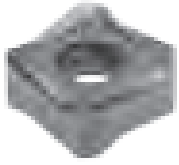

SNH(K)X-MP



SNH(K)X-MK | LP | MP | LN

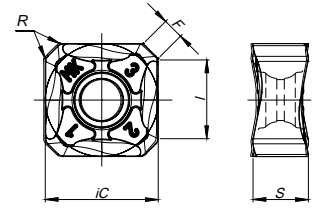

SNH(K)X-MK



SNHX-LN



SNHX-W

4 Cutting edges (2R + 2L)



SNHX-W

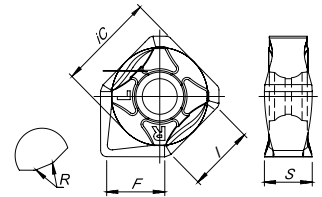

Geometry code	ISO Reference	P						M	K						N	S	Dimensions Dimensões Dimensiones (mm)						
		CVD		PVD				PVD	CVD			PVD			UNC	PVD							
		T9	X5	G4	T1	P4	G6	X9	L5	L6	L9	X5	G4	T1	P4	G6						10	X9
1112293	SNKX 1206 ANSN-MP	⊗		⊗	⊗		⊗						⊗	⊗		⊗			iC	S	I	R	F
1112249	SNKX 1206 ANEN-MK								⊗	⊗	⊗								12,70	6,35	9,30	0,80	2,00
1111452	SNHX 1206 ANEN-LP				⊗	⊗		⊗						⊗	⊗		⊗		12,70	6,35	9,30	0,80	2,00
1111502	SNHX 1206 ANSN-MP	⊗	⊗	⊗	⊗	⊗					⊗	⊗	⊗	⊗					12,70	6,35	9,30	0,80	2,00
1111503	SNHX 1206 ANEN-MK		⊗	⊗	⊗				⊗		⊗	⊗	⊗						12,70	6,35	9,30	0,80	2,00
1111504	SNHX 1206 ANFN-LN																⊗		12,70	6,35	9,30	0,80	2,00
1111899	SNHX 1206 ANFN-W*		⊗		⊗							⊗		⊗					12,70	6,30	9,30	0,40	7,60

⊗ First choice | Primeira opção | 1ª opción ⊗ Stock item | Produto de stock | Itens de stock ○ Available under request (see page A-9) | Disponível sobre consulta (consulte a página A-9) | Disponible bajo consulta (mire página A-9) Insert order code = (1) Geometry Code + (2) Grade Code

* Wiper insert with 2 rights and 2 left-hand cutting edges.

A
MILLING
Overview
Face milling
Hifeed milling
Shoulder milling
Profile milling
Hardmill
Center & Chamfer
Spot face
Spare Parts
Technical Data
End Mills

PLUS 90945

RECOMMENDED CUTTING CONDITIONS | Condições de corte recomendadas | Condiciones de corte recomendables

ISO	PSM	Material	HB (Brinell)	Vc (m/min)						
				← Wear Resistance						
				PH0910	PH5705	PH5320	PHP910	PHP920	PH7920	PHP930
P	1	Unalloyed Steel	125-220	-	-	-	180-250	180-250	180-240	160-220
	2	Low-Alloyed Steel	220-280	-	-	-	160-240	160-230	160-220	140-200
	3	High-Alloyed Steel	280-380	-	-	-	140-230	140-220	140-210	120-190
M	4	SS - Ferritic / Martensitic	200-330	-	-	-	-	-	140-220	140-200
	5	SS - Austenitic	200-330	-	-	-	-	-	130-180	120-160
	6	SS - Austenitic-ferritic (Duplex)	230-260	-	-	-	-	-	120-160	100-140
K	7	Malleable Cast Iron	130-230	-	160-290	150-280	180-300	160-270	160-260	150-240
	8	Grey Cast Iron	180-245	-	170-320	160-320	160-250	140-250	140-240	140-230
	9	Nodular Cast iron	160-250	-	140-200	100-190	150-210	120-210	120-200	100-190
N	10	Aluminium and Non Ferrous	30-130	100-2000	-	-	-	-	-	-
S	11	Heat Resistant Super Alloys	200-320	-	-	-	-	-	-	30-100

(Note 1) Cutting conditions $a_e/D_c=70\%$.

(Note 2) It's possible to occur vibrations in certain cases. Please reduce depth of cut and / or reduce cutting conditions in following cases:

- When using long shank;
- When using long tool overhang with arbor type;
- When application has poor clamping rigidity or when using a low rigidity machine.

(Note 3) PH5... and PHS... can be used wet or dry. PH7... use only air.

GRADES SELECTION GUIDE | Guia para selecção de graus | Tabla para selección de calidades

ISO	PSM	Material	HB (Brinell)	Grades											
				← Wear Resistance							Toughness →				
				PH0910	PH5705	PH5320	PHP910	PHP920	PH7920	PHP930	PHH930	PH7930	PH5740	PH5740	PH7740
P	1	Unalloyed Steel	125-220				✓	✓	✓	✓		✓		✓	✓
	2	Low-Alloyed Steel	220-280				✓	✓	✓	✓		✓		✓	✓
	3	High-Alloyed Steel	280-380				✓	✓	✓	✓		✓		✓	✓
M	4	SS - Ferritic / Martensitic	200-330								✓	✓			✓
	5	SS - Austenitic	200-330								✓	✓			✓
	6	SS - Austenitic-ferritic (Duplex)	230-260								✓	✓			✓
K	7	Malleable Cast Iron	130-230		✓	✓	✓	✓	✓	✓		✓	✓		✓
	8	Grey Cast Iron	180-245		✓	✓	✓	✓	✓	✓		✓	✓		✓
	9	Nodular Cast iron	160-250		✓	✓	✓	✓	✓	✓		✓	✓		✓
N	10	Aluminium and Non Ferrous	30-130	✓											
S	11	Heat Resistant Super Alloys	200-320								✓	✓			✓

● Good Conditions

● Average Conditions

● Difficult Conditions

CHIP-BREAKER SELECTION GUIDE | Guia para aplicações do quebra- aparas | Guía para aplicación del rompevirutas

ISO	PSM	Material	HB (Brinell)	Chip-Breaker Application	
				1st choice	Difficult Operations
P	1	Unalloyed Steel	125-220	SNHX 12... LP	SNH(K)X 12... MP
	2	Low-Alloyed Steel	220-280	SNHX 12... LP	SNH(K)X 12... MP
	3	High-Alloyed Steel	280-380	SNH(K)X 12... MP	-
M	4	SS - Ferritic / Martensitic	200-330	SNHX 12... LP	-
	5	SS - Austenitic	200-330	SNHX 12... LP	-
	6	SS - Austenitic-ferritic (Duplex)	230-260	SNHX 12... LP	-
K	7	Malleable Cast Iron	130-230	SNH(K)X 12... MK	-
	8	Grey Cast Iron	180-245	SNH(K)X 12... MK	-
	9	Nodular Cast iron	160-250	SNH(K)X 12... MK	-
N	10	Aluminium and Non Ferrous	30-130	SNHX 12... LN	-
S	11	Heat Resistant Super Alloys	200-320	SNHX 12... LP	-



PDF

Vc (m/min)					Feed fz (mm/t)				
Toughness →									
PHH930	PH7930	PH5740	PHS740	PH7740	SNHX 12... LP	SNH(K)X 12... MP	SNH(K)X 12... MK	SNHX 12... LN	SNHX 12... W
-	160-220	-	140-220	140-200	0,10-0,35	0,10-0,35	-	-	0,10-0,35
-	140-200	-	120-200	130-180	0,10-0,35	0,10-0,35	-	-	0,10-0,35
-	120-190	-	100-190	100-170	0,10-0,30	0,10-0,30	-	-	0,10-0,30
140-210	140-200	-	-	130-180	0,10-0,30	-	-	-	-
120-170	120-160	-	-	110-160	0,10-0,30	-	-	-	-
100-150	100-140	-	-	90-150	0,10-0,25	-	-	-	-
-	150-240	160-260	-	140-220	0,10-0,35	-	0,10-0,35	-	0,10-0,40
-	140-230	140-240	-	120-210	0,10-0,35	-	0,10-0,35	-	0,10-0,40
-	100-190	120-200	-	100-190	0,10-0,30	-	0,10-0,30	-	0,10-0,40
-	-	-	-	-	-	-	-	0,10-0,35	-
30-110	30-100	-	-	30-100	0,07-0,20	-	-	-	-

WIPER INSERTS

Recommended Cutting Conditions:

- f_z should be equal to $0,8 \times F_w / Z$
- Axial depth of cut is 0,5 to 0,8mm.

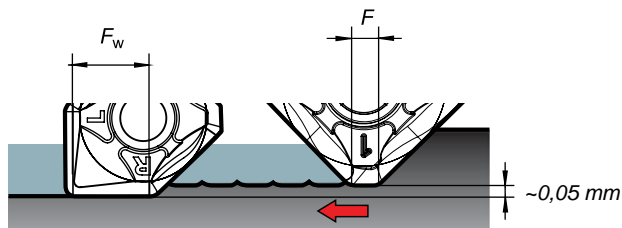

Example:

- The width of the parallel land (F) of the insert is 2mm.
- To obtain a good surface finishing, the feed per revolution should be a maximum of 80% of 2mm = 1,6mm.
- The wiper insert will have a parallel land (F_w) with a width of 7,6mm.
- Result: Feed per revolution (f_r) could be increased from 1,6mm to 6,1mm (80% of 7,6mm).

Note: Other limitations, such as machine power, must be taken into consideration.

How to use a wiper insert:

- Since wiper is one corner use to standard cutters, please attach the insert with the parallel land down to the workspace cutting surface.

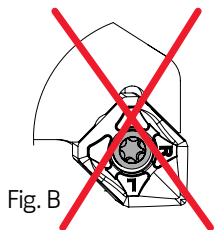
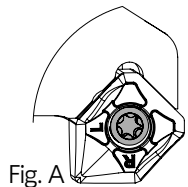

When using wiper insert, install the insert as shown on Fig. A if the insert is installed as shown on Fig. B breakage of the insert is inevitable and normal surface finish can not be obtained.

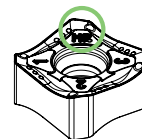

This point shows the SNKX insert difference to SNHX

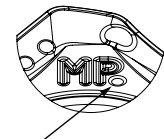

Put the same side of insert in each pocket for best radial and axial runout when using SNKX.

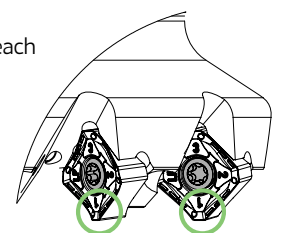

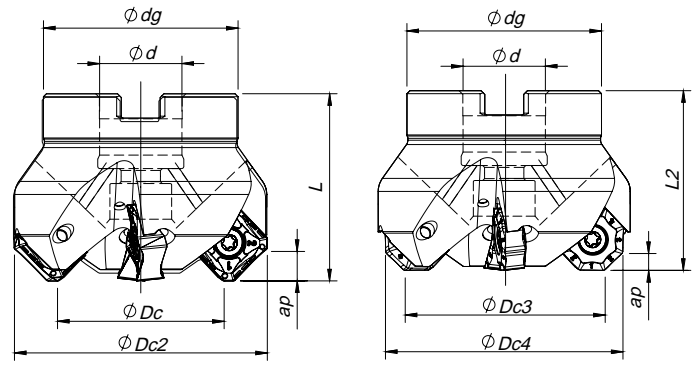
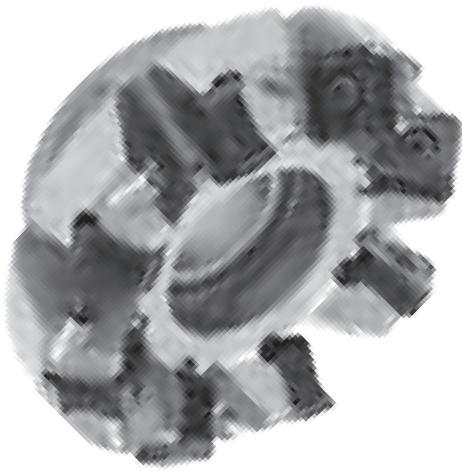

Arbor Mounting
 $K_r = 45^\circ$ | $\gamma_p = -6^\circ$

Order code Código	Reference Referência Referencia		Dimensions Dimensões Dimensiones (mm)								Kg	Specifications		Insert Pastilha Inserto	Stock
			ϕDc	$\phi Dc2$	$\phi Dc3$	$\phi Dc4$	ϕd	ϕdg	L	L2		Arbor Type	Ap (mm)		
181088900	063A91245-05-06-022050	5	63	80,1	66,6	76,0	22	52	50	48	0,81	A	3,8 8,5	ON...06 SN...16	
181089000	080A91245-06-06-027050	6	80	97,1	83,6	93,0	27	60	50	48	1,06	B	3,8 8,5	ON...06 SN...16	
181089100	080A91245-08-06-027050	8	80	97,1	83,6	93,0	27	60	50	48	1,09	B	3,8 8,5	ON...06 SN...16	
181089200	100A91245-07-06-032063	7	100	117,1	103,6	113,0	32	80	63	61	2,24	B	3,8 8,5	ON...06 SN...16	
181089300	100A91245-10-06-032063	10	100	117,1	103,6	113,0	32	80	63	61	2,28	B	3,8 8,5	ON...06 SN...16	
181089400	125A91245-08-06-040063	8	125	142,1	128,6	138,0	40	90	63	61	3,04	B	3,8 8,5	ON...06 SN...16	
181089500	160A91245-10-06-U040063	10	160	177,1	163,6	173,0	40	110	63	61	4,40	C	3,8 8,5	ON...06 SN...16	
181089600	200A91245-12-06-U060063	12	200	217,1	203,6	213,0	60	172	63	61	9,12	C	3,8 8,5	ON...06 SN...16	
181089700	250A91245-14-06-U060063	14	250	267,1	253,6	263,0	60	172	63	61	11,93	C	3,8 8,5	ON...06 SN...16	

Stock item | Produto de stock | Itens de stock

Available under request (see page A-9) | Disponível sobre consulta (consulte a página A-9) | Disponible bajo consulta (mire pagina A-9)

SPARE PARTS | Complementos | Repuestos

Cutter ϕDc	Order separately				Order separately	
	Insert Screw	Key (Torx)	Key (Torx - Nm)	Torque Value	Screw	DIN 6368 Wrench
A91245 - 63	P0451400	XT20	DT2050	5,0	-	-
A91245 - 80	P0451400	XT20	DT2050	5,0	J0123510	SD6368-12
A91245 -100	P0451400	PT20	DT2050	5,0	J0164110	SD6368-16
A91245 -125	P0451400	PT20	DT2050	5,0	J0204610	SD6368-20
A91245 - 160-250	P0451400	PT20	DT2050	5,0	-	-

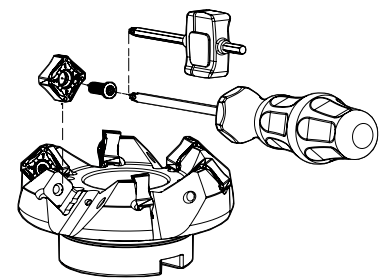

Note: The toolholder is supplied with the XT/PT key. To order the DT key please check the page A-241.
 Check the procedures for the clamping screws on the page A-241.

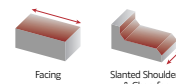

ONH(K)X 0606 | SNH(K)X 1606 | Inserts | Pastilhas | Plaquetas

A

MILLING

Overview

Face milling

Hifeed milling

Shoulder milling

Profile milling

Hardmill

Center & Chamfer

Spotface

Spare Parts

Technical Data

End Mills

ONH(K)X-LP



ONH(K)X-MP
(PHP grade)



ONH(K)X-MK



ONH(K)X-LP | MP | MK

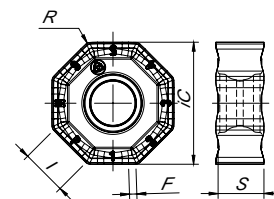

ONHX-W
(8 Cutting edges (4R + 4L))



ONHX-LS
(PHH grade) **NEW**



ONHX-W

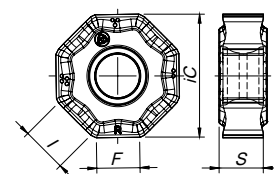

SNHX-LP

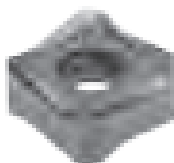

SNH(K)X-MP
(PHS grade)

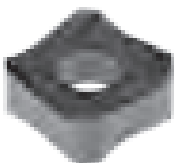

SNH(K)X-MK



SNH(K)X-MK | LP | MP

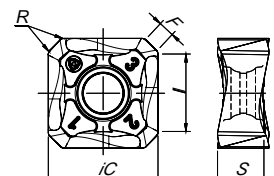

(1) Geometry code	(2) Grade code ISO Reference	P						M			K						S			Dimensions Dimensões Dimensiones (mm)						
		CVD		PVD				PVD			CVD		PVD				PVD			iC	S	I	R	F		
		T9	G4	T1	P3	P4	G6	P3	X9	G6	L5	L6	L9	G4	T1	P3	P4	G6	P3						X9	G6
1111954	ONHX 0606 ANEN-LP			⊗		⊗	⊗															16,50	6,35	6,20	0,80	1,00
1112696	ONHX 0606 ANEN-LS								⊗											⊗		16,50	6,35	6,20	0,80	1,00
1111955	ONHX 0606 ANEN-MP			⊗			⊗								⊗					⊗		16,50	6,35	6,20	0,80	1,00
1111956	ONHX 0606 ANEN-MK										⊗		⊗									16,50	6,35	6,20	0,80	1,00
1112053	ONHX 0606 ANEN-W*		⊗								⊗			⊗								16,50	6,35	6,20	-	6,00
1112284	ONKX 0606 ANEN-LP		⊗	⊗	⊗		⊗	⊗				⊗	⊗	⊗	⊗				⊗	⊗		16,50	6,35	6,20	0,80	1,00
1112287	ONKX 0606 ANEN-MP	⊗	⊗	⊗			⊗						⊗	⊗						⊗		16,50	6,35	6,20	0,80	1,00
1112291	ONKX 0606 ANEN-MK										⊗		⊗									16,50	6,35	6,20	0,80	1,00
1111951	SNHX 1606 ANER-LP		⊗	⊗		⊗	⊗			⊗				⊗	⊗					⊗		16,50	6,35	12,50	0,80	2,20
1111952	SNHX 1606 ANER-MP	⊗		⊗			⊗								⊗					⊗		16,50	6,35	12,50	0,80	2,20
1111953	SNHX 1606 ANER-MK												⊗									16,50	6,35	12,50	0,80	2,20
1112281	SNKX 1606 ANER-MP	⊗	⊗	⊗			⊗							⊗	⊗					⊗		16,50	6,35	12,50	0,80	2,20
1112282	SNKX 1606 ANER-MK												⊗	⊗								16,50	6,35	12,50	0,80	2,20

⊗ First choice | Primeira opção | 1ª opción ⊗ Stock item | Produto de stock | Itens de stock ○ Available under request (see page A-9) | Disponível sobre consulta (consulte a página A-9) | Disponible bajo consulta (mire página A-9) Insert order code = (1) Geometry Code + (2) Grade Code

* Wiper insert with 4 rights and 4 left-hand cutting edges.

GRADES SELECTION GUIDE | Guia para selecção de graus | Tabla para selección de calidades

ISO	PSM	Material	HB (Brinell)	Grades									
				← Wear Resistance				Toughness →					
				PH5705	PH5320	PHP920	PH7920	PHP930	PHH930	PH7930	PH5740	PHS740	PH7740
P	1	Unalloyed Steel	125-220	●	●	●	●	●	●	●	●	●	●
	2	Low-Alloyed Steel	220-280			●	●	●		●		●	●
	3	High-Alloyed Steel	280-380			●	●	●		●		●	●
M	4	SS - Ferritic / Martensitic	200-330							●	●		●
	5	SS - Austenitic	200-330							●	●		●
	6	SS - Austenitic-ferritic (Duplex)	230-260							●	●		●
K	7	Malleable Cast Iron	130-230	●	●	●	●	●		●	●		●
	8	Grey Cast Iron	180-245	●	●	●	●	●		●	●		●
	9	Nodular Cast iron	160-250	●	●	●	●	●		●	●		●
S	11	Heat Resistant Super Alloys	200-320							●	●		●

● Good Conditions

● Average Conditions

● Difficult Conditions

RECOMMENDED CUTTING CONDITIONS | Condições de corte recomendadas | Condiciones de corte recomendables

ISO	PSM	Material	HB (Brinell)	Vc (m/min)					
				← Wear Resistance			Toughness →		
				PH5705	PH5320	PHP920	PH7920	PHP930	PHH930
P	1	Unalloyed Steel	125-220	-	-	180-250	180-240	160-230	-
	2	Low-Alloyed Steel	220-280	-	-	160-230	160-220	140-210	-
	3	High-Alloyed Steel	280-380	-	-	140-220	140-210	120-200	-
M	4	SS - Ferritic / Martensitic	200-330	-	-	-	-	-	140-210
	5	SS - Austenitic	200-330	-	-	-	-	-	120-170
	6	SS - Austenitic-ferritic (Duplex)	230-260	-	-	-	-	-	100-150
K	7	Malleable Cast Iron	130-230	160-290	150-280	160-270	160-260	150-250	-
	8	Grey Cast Iron	180-245	170-320	160-320	140-250	140-240	140-230	-
	9	Nodular Cast iron	160-250	140-200	100-190	120-210	120-200	100-200	-
S	11	Heat Resistant Super Alloys	200-320	-	-	-	-	-	30-110

ISO	PSM	Material	HB (Brinell)	Vc (m/min)				Feed fz (mm/t)
				← Wear Resistance		Toughness →		
				PH7930	PH5740	PHS740	PH7740	SNH(K)X/ONH(K)X
P	1	Unalloyed Steel	125-220	160-220	-	140-220	140-200	0,15 (0,25) 0,4
	2	Low-Alloyed Steel	220-280	140-200	-	120-200	130-180	0,15 (0,25) 0,4
	3	High-Alloyed Steel	280-380	120-190	-	100-190	100-170	0,15 (0,25) 0,4
M	4	SS - Ferritic / Martensitic	200-330	140-200	-	-	130-180	0,1 (0,20) 0,3
	5	SS - Austenitic	200-330	120-160	-	-	110-160	0,1 (0,20) 0,3
	6	SS - Austenitic-ferritic (Duplex)	230-260	100-140	-	-	90-150	0,1 (0,20) 0,3
K	7	Malleable Cast Iron	130-230	150-240	160-260	-	140-220	0,15 (0,25) 0,4
	8	Grey Cast Iron	180-245	140-230	140-240	-	120-210	0,14 (0,25) 0,4
	9	Nodular Cast iron	160-250	100-190	120-200	-	100-190	0,14 (0,25) 0,4
S	11	Heat Resistant Super Alloys	200-320	30-100	-	-	30-100	0,1 (0,15) 0,17

(Note 1) Cutting conditions $a_e/D_c=70\%$.

(Note 2) It's possible to occur vibrations in certain cases. Please reduce depth of cut and / or reduce cutting conditions in following cases:

- When using long shank;
- When using long tool overhang with arbor type;
- When application has poor clamping rigidity or when using a low rigidity machine.

(Note 3) PH5... and PHS... can be used wet or dry. PH7... use only air.



PDF

CHIP-BREAKER SELECTION GUIDE | Guia para aplicações do quebra- aparas | Guía para aplicación del rompevirutas

Selection Example:

ISO	PSM	Material	HB (Brinell)	Vc (m/min)		Feed fz (mm/t)		
				← Wear Resistance			Toughness →	
				PH5705	PH5740		SNHX/ONHX	
K	7	Malleable cast iron	130-230	170 (190) 305	150 (170) 260	0,15 (0,25) 0,40		
	8	Grey cast iron	180-245	180 (240) 350	155 (190) 290	0,14 (0,25) 0,40		
	9	Nodular cast iron	160-250	130 (160) 210	115 (140) 180	0,14 (0,25) 0,40		

This example shows the recommended starting cutting conditions, indicated in **Bold type**.

ISO	PSM	Material	HB (Brinell)	Chip-Breaker Application	
				1 st choice	Alternative
P	1	Unalloyed Steel	125-220	LP	MP
	2	Low-Alloyed Steel	220-280	LP	MP
	3	High-Alloyed Steel	280-380	MP	-
M	4	SS - Ferritic / Martensitic	200-330	LS	LP
	5	SS - Austenitic	200-330	LS	LP
	6	SS - Austenitic-ferritic (Duplex)	230-260	LS	LP
K	7	Malleable Cast Iron	130-230	MK	-
	8	Grey Cast Iron	180-245	MK	-
	9	Nodular Cast iron	160-250	MK	LP
S	11	Heat Resistant Super Alloys	200-320	LS	LP

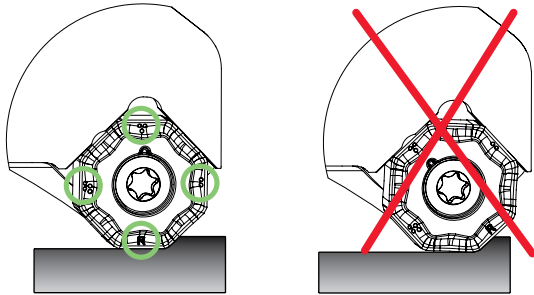

The points and letter (R or L) on the insert indicates the side that should be parallel to the workspace material.

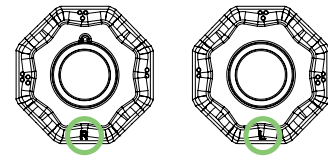

Wiper insert with 4 Right and 4 Left-hand cutting edges. The side work of the insert it's indicated by the letter R (Right) & L (Left).

WIPER INSERTS

Recommended Cutting Conditions:

- f_z should be equal to $0,8 \times F_w / Z$
- Axial depth of cut is 0,5 to 0,8mm.

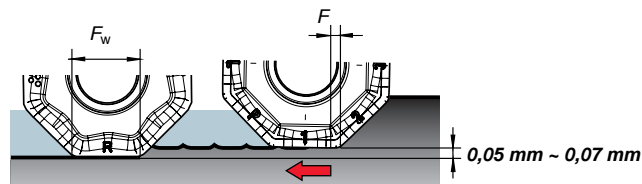

Example:

- The width of the parallel land (F) of the insert is 1mm.
- To obtain a good surface finishing, the feed per revolution should be a maximum of 80% of 1mm = 0,8mm.
- The wiper insert will have a parallel land (F_w) with a width of 6,0mm.
- Result: Feed per revolution (f_n) could be increased from 0,8mm to 4,8mm (80% of 6,0mm).

Note: Other limitations, such as machine power, must be taken into consideration.

How to use a wiper insert:

- Since wiper is one corner use to standard cutters, please attach the insert with the parallel land down to the workspace cutting surface.
- The points and the letter (R or L) on the insert indicates the side that should be parallel to the workspace material.
- The side work of the insert it's indicated by the letter (R - Right & L - Left).

LINEPRO 06045



Arbor Mounting

$K_r=45^\circ$ | $\gamma_p=+19^\circ$

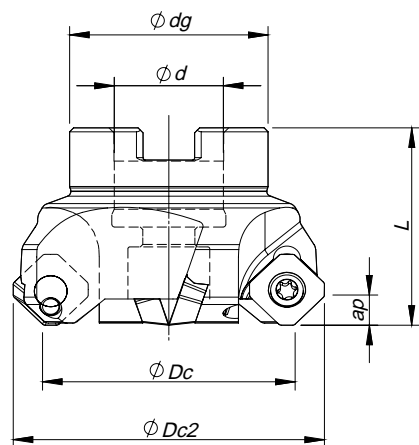

Order code Código	Reference Referência Referencia		Dimensions Dimensões Dimensiones (mm)					Kg	Specifications		Insert Pastilha Inserto	Stock
			ϕDc	$\phi Dc2$	ϕd	ϕdg	L		Arbor Type	A_p max (mm)		
181163200	050A06045-04-19-022040	4	50	62	22	42	40	0,350	A	6,0	SE...T/W 1204	○
181148800	063A06045-05-19-022050	5	63	75	22	42	50	0,800	A	6,0	SE...T/W 1204	○
181148900	080A06045-06-19-027050	6	80	92	27	50	50	1,150	A	6,0	SE...T/W 1204	○
181149000	100A06045-06-19-032050	6	100	112	32	64	50	1,700	A	6,0	SE...T/W 1204	○
181163300	125A06045-07-19-040063	7	125	132	40	85	63	2,750	B	6,0	SE...T/W 1204	○
181040300	160A06045-08-19-U040063	8	160	172	40	100	63	4,600	C	6,0	SE...T/W 1204	○

⊗ Stock item | Produto de stock | Itens de stock

○ Available under request (see page A-9) | Disponível sobre consulta (consulte a página A-9) | Disponible bajo consulta (mire pagina A-9)

SEH... 1204 || Inserts | Pastilhas | Plaquetas

SEHW



SEHT

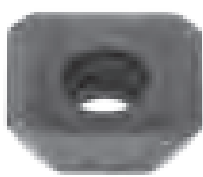

SEHT-LN



SEHW | SEHT | SEHT-LN

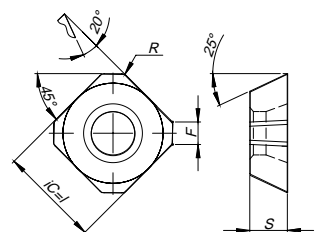

Geometry code	ISO Reference	P		M	K		N	Dimensions Dimensões Dimensiones (mm)			
		PVD			PVD		UNC	iC	S	I	F
		68	I5	I5	68	I5	10				
1110216	SEHT 1204 AFEN	⊗	⊗	⊗	⊗	⊗		12,70	4,76	12,70	2,80
1110218	SEHT 1204 AFTN	⊗	⊗	⊗	⊗	⊗		12,70	4,76	12,70	2,80
1112283	SEHT 1204 AFFN-LN						⊗	12,70	4,76	12,70	2,00
1110219	SEHW 1204 AFEN	⊗	⊗	⊗	⊗	⊗		12,70	4,76	12,70	2,80
1110222	SEHW 1204 AFTN	⊗	⊗	⊗	⊗	⊗		12,70	4,76	12,70	2,80

⊗ First choice | Primeira opção | 1ª opción

⊗ Stock item | Produto de stock | Itens de stock

○ Available under request (see page A-9) | Disponível sobre consulta (consulte a página A-9) | Disponible bajo consulta (mire pagina A-9)

Insert order code = (1) Geometry Code + (2) Grade Code

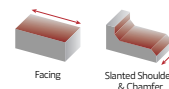

SPARE PARTS || Complementos | Repuestos

Cutter ØDc	Insert Screw	Key (Torx)	Order separately	
			Key (Torx - Nm)	Torque Value
A06045 - 50 - 160	P0501100	PT20	DT2050	5,0

Note: The toolholder is supplied with the XT/PT key. To order the DT key please check the page A-241.
Check the procedures for the clamping screws on the page A-241.

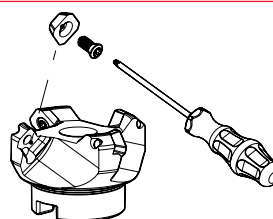

GRADES SELECTION GUIDE || Guia para seleção de graus | Tabla para selección de calidades

ISO	PSM	Material	HB (Brinell)	Grades		
				← Wear Resistance		Toughness →
				PH0910	PH6920	PH6740
P	1	Unalloyed steel	125-220	●	✓	✓
	2	Low-alloyed steel	220-280		✓	✓
	3	High-alloy steel	280-380		✓	✓
M	4	SS - Ferritic / Martensitic	200-330			✓
	5	SS - Austenitic	200-330			✓
	6	SS - Austenitic-ferritic (Duplex)	230-260			✓
K	7	Malleable cast iron	130-230		✓	✓
	8	Grey cast iron	180-245		✓	✓
	9	Nodular cast iron	160-250		✓	✓
N	10	Aluminium and Non Ferrous	30-130	✓		

● Good Conditions
 ● Average Conditions
 ● Difficult Conditions

RECOMMENDED CUTTING CONDITIONS || Condições de corte recomendadas | Condiciones de corte recomendables

ISO	PSM	Material	HB (Brinell)	Vc (m/min)			Feed fz (mm/t)		
				← Wear Resistance		Toughness →			
				PH0910	PH6920	PH6740	SEHT 1204...	SEHT 1204 LN	SEHW 1204...
P	1	Unalloyed Steel	125-220	-	150-230	130-160	0,10-0,20	-	0,10-0,20
	2	Low-Alloyed Steel	220-280	-	140-220	120-150	0,10-0,20	-	0,10-0,20
	3	High-Alloyed Steel	280-380	-	130-180	100-130	0,10-0,20	-	0,10-0,20
M	4	SS - Ferritic / Martensitic	200-330	-	-	100-120	0,10-0,15	-	0,10-0,20
	5	SS - Austenitic	200-330	-	-	80-110	0,10-0,15	-	0,10-0,20
	6	SS - Austenitic-ferritic (Duplex)	230-260	-	-	70-100	0,10-0,15	-	0,10-0,20
K	7	Malleable Cast Iron	130-230	-	-	130-250	0,10-0,25	-	0,10-0,25
	8	Grey Cast Iron	180-245	-	-	110-220	0,10-0,25	-	0,10-0,25
	9	Nodular Cast iron	160-250	-	-	80-170	0,10-0,25	-	0,10-0,25
N	10	Aluminium and Non Ferrous	30-130	350-1400	-	-	0,10-0,25	-	-

(Note 1) Cutting conditions ae/DC=70%

(Note 2) Cutting conditions should be adjusted according to the machine and work rigidity.

(Note 3) If chattering occurs, reduce ap and Vc by 30% and keep the same fz per tooth.

CHIP-BREAKER SELECTION GUIDE || Guia para aplicações do quebra- aparas | Guía para aplicación del rompevirutas

ISO	PSM	Material	HB (Brinell)	Chip-Breaker Application	
				1st choice	Difficult Operations
P	1	Unalloyed Steel	125-220	SEHT 12... AFEN	SEHW 12... AFEN
	2	Low-Alloyed Steel	220-280	SEHT 12... AFTN	SEHW 12... AFTN
	3	High-Alloyed Steel	280-380	SEHT 12... AFTN	SEHW 12... AFTN
M	4	SS - Ferritic / Martensitic	200-330	SEHT 12... AFEN	SEHW 12... AFEN
	5	SS - Austenitic	200-330	SEHT 12... AFEN	SEHW 12... AFEN
	6	SS - Austenitic-ferritic (Duplex)	230-260	SEHW 12... AFEN	-
K	7	Malleable Cast Iron	130-230	SEHT 12... AFEN	SEHW 12... AFEN
	8	Grey Cast Iron	180-245	SEHT 12... AFEN	SEHW 12... AFEN
	9	Nodular Cast iron	160-250	SEHW 12... AFEN	SEHW 12... AFTN
N	10	Aluminium and Non Ferrous	30-130	SEHT 12... AFFN-LN	-

LINEPRO 09945

A

MILLING

Overview

Face milling

Hi-feed milling

Shoulder milling

Profile milling

Hardmill

Center & Chamfer

Spotface

Spare Parts

Technical Data

End Mills

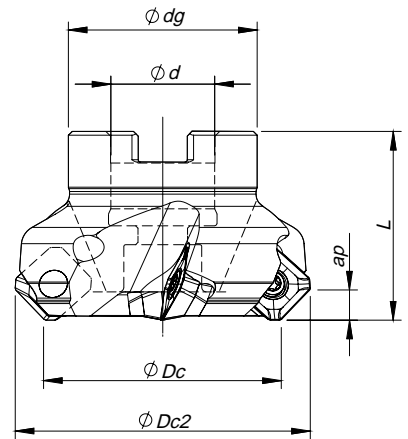

Arbor Mounting

$$K_r=45^\circ \mid \gamma_p=+20^\circ \sim +21^\circ$$

Order code Código	Reference Referência Referencia		Dimensions Dimensões Dimensiones (mm)					Kg	Specifications		Insert Pastilha Inserto	Stock
			ϕDc	$\phi Dc2$	ϕd	ϕdg	L		Arbor Type	A_p max (mm)		
181034700	050A09945-04-20-U022040	4	50	63	22	40	40	0,36	A	6,0	SE...13T3	
181024200	063A09945-05-21-U022040	5	63	76	22	48	40	0,59	A	6,0	SE...13T3	
181024300	080A09945-06-21-U027050	6	80	93	27	60	50	1,02	B	6,0	SE...13T3	
181024400	100A09945-07-21-U032050	7	100	113	32	70	50	1,52	B	6,0	SE...13T3	
181024500	125A09945-08-21-U040063	8	125	138	40	90	63	3,16	B	6,0	SE...13T3	
181024600	160A09945-10-21-U040063	10	160	173	40	110	63	4,61	C	6,0	SE...13T3	
181051400	250A09945-24-21-U060063L	24	250	263	60	172	63	13,89	C	6,0	SE...13T3	
181024800	250A09945-24-21-U060063	24	250	263	60	172	63	13,89	C	6,0	SE...13T3	

Stock item | Produto de stock | Itens de stock

Available under request (see page A-9) | Disponível sobre consulta (consulte a página A-9) | Disponible bajo consulta (mire pagina A-9)

SPARE PARTS | Complementos | Repuestos

Cutter ϕDc	Order separately				Order separately	
	Insert Screw	Key (Torx)	Key (Torx - Nm)	Torque Value	Shim	Shim Screw
A09945 - 50 - 80	P0351200	XT15	DT1530	3,0	CS130300	T0503509
A09945 - 100-250	P0351200	PT15	DT1530	3,0	CS130300	T0503509

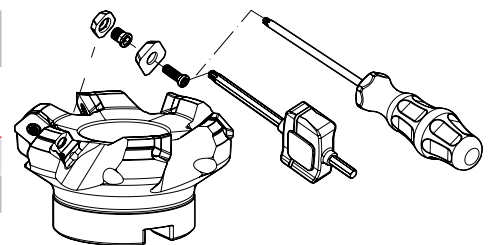

Note: The toolholder is supplied with the XT/PT key. To order the DT key please check the page A-241.
Check the procedures for the clamping screws on the page A-241.

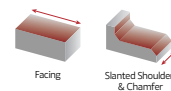

SE... 13T3 | Inserts | Pastilhas | Plaquetas

SEHT



SEHW

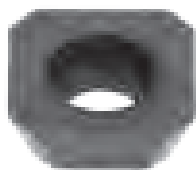

SEHT-LN



SEHT | SEHW | SEHT-LN

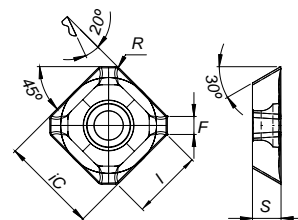

SEHT-W



SEHT-W

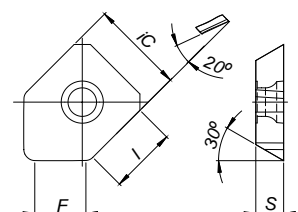

	(2) Grade code	P		M	K		N	Dimensions Dimensões Dimensiones (mm)			
		PVD		PVD			UNC	ic	S	I	F
		68	I5	I5	68	I5	10				
(1) Geometry code	ISO Reference	PH6920	PH6740	PH6740	PH6920	PH6740	PH0910				
1110559	SEHT 13T3 AGSN	⊗	⊗	⊗	⊗	⊗		13,35	3,97	10,0	2,0
1111586	SEHT 13T3 AGFN-LN						⊗	13,35	3,97	10,0	2,3
1110627	SEHT 13T3 AGSN-W	⊗			⊗			13,35	3,97	10,0	8,2
1111146	SEHW 13T3 AGFN	⊗			⊗			13,35	3,97	10,0	2,0

⊗ First choice | Primeira opção | 1ª opción ⊗ Stock item | Produto de stock | Itens de stock ○ Available under request (see page A-9) | Disponível sobre consulta (consulte a página A-9) | Disponible bajo consulta (mire página A-9) Insert order code = (1) Geometry Code + (2) Grade Code

GRADES SELECTION GUIDE | Guia para selecção de graus | Tabla para selección de calidades

ISO	Material	HB (Brinell)	Grades		
			← Wear Resistance		Toughness →
			PH0910	PH6920	PH6740
P	Unalloyed steel	125-220	●	●	●
	Low-alloyed steel	220-280		✓	✓
	High-alloy steel	280-380		✓	✓
M	SS - Ferritic / Martensitic	200-330			✓
	SS - Austenitic	200-330			✓
	SS - Austenitic-ferritic (Duplex)	230-260			✓
K	Malleable cast iron	130-230		✓	✓
	Grey cast iron	180-245		✓	✓
	Nodular cast iron	160-250		✓	✓
N	Aluminium and Non Ferrous	30-130	✓		

● Good Conditions
● Average Conditions
● Difficult Conditions

RECOMMENDED CUTTING CONDITIONS | Condições de corte recomendadas | Condiciones de corte recomendables

ISO	PSM	Material	HB (Brinell)	Vc (m/min)			Feed fz (mm/t)			
				← Wear Resistance		Toughness →	SEHT 13T3 AGSN	SEHW 13T3 AGFN	SEHT 13T3 AGFN-LN	SEHT 13T3 AGSN-W
				PH0910	PH6920	PH6740				
P	1	Unalloyed Steel	125-220	-	180-340	180-240	0,10-0,25	-	-	0,10-0,30
	2	Low-Alloyed Steel	220-280	-	180-340	160-220	0,10-0,20	-	-	0,10-0,30
	3	High-Alloyed Steel	280-380	-	180-330	140-210	0,10-0,20	-	-	0,10-0,30
M	4	SS - Ferritic / Martensitic	200-330	-	-	140-220	0,10-0,20	-	-	-
	5	SS - Austenitic	200-330	-	-	130-180	0,10-0,20	-	-	-
	6	SS - Austenitic-ferritic (Duplex)	230-260	-	-	120-160	0,10-0,20	-	-	-
K	7	Malleable Cast Iron	130-230	-	-	160-260	0,10-0,25	0,10-0,25	-	0,10-0,30
	8	Grey Cast Iron	180-245	-	-	140-240	0,10-0,25	0,10-0,25	-	0,10-0,30
	9	Nodular Cast iron	160-250	-	-	120-200	0,10-0,20	0,10-0,20	-	0,10-0,30
N	10	Aluminium and Non Ferrous	30-130	350-1400	-	-	0,10-0,20	-	0,10-0,20	-

(Note 1) Cutting conditions ae/DC=70%

(Note 2) Cutting conditions should be adjusted according to the machine and work rigidity.

(Note 3) If chattering occurs, reduce ap and Vc by 30% and keep the same fz per tooth.

CHIP-BREAKER SELECTION GUIDE | Guia para aplicações do quebra- aparas | Guía para aplicación del rompevirutas

ISO	PSM	Material	HB (Brinell)	Chip-Breaker Application	
				1st choice	Difficult Operations
P	1	Unalloyed Steel	125-220	SEHT... AGSN	-
	2	Low-Alloyed Steel	220-280	SEHT... AGSN	-
	3	High-Alloyed Steel	280-380	SEHT... AGSN	-
M	4	SS - Ferritic / Martensitic	200-330	SEHT... AGSN	SEHW... AGFN
	5	SS - Austenitic	200-330	SEHT... AGSN	SEHW... AGFN
	6	SS - Austenitic-ferritic (Duplex)	230-260	SEHT... AGSN	SEHW... AGFN
K	7	Malleable Cast Iron	130-230	SEHW... AGFN	-
	8	Grey Cast Iron	180-245	SEHW... AGFN	-
	9	Nodular Cast iron	160-250	SEHW... AGFN	-
N	10	Aluminium and Non Ferrous	30-130	SEHT... AGFN-LN	-

WIPER INSERTS

Rec. Cutting Conditions

- F_w at least 40% larger than f_n ($f_n = f_z \times Z$);
- Axial depth of cut is 0,5 - 0,8 mm;

Example:

- The width of parallel land (F) of the SEHT insert is 2,0 mm.
 - With a cutter of 10 inserts and using a feed per tooth (f_z) of 0,3 mm, the feed per revolution (f_n) will be 3 mm, i.e. 66% bigger than the parallel land.
 - To obtain a good surface finishing, the feed per revolution should be a maximum 80% of 2,0 mm = 1,6 mm.
 - The wiper insert will have a parallel land (F_w) with a width of approximately 8,2 mm.
 - Result: Feed per revolution (f_n) could be increased from 1,6 mm to 60% of 6,0 mm = 4,9 mm.
- Note: Other limitations, such as machine power, must be taken into consideration.

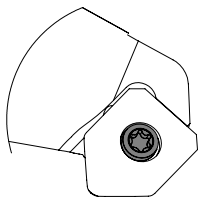

Fig. A

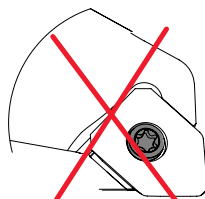

Fig. B

When using wiper insert, install the insert as shown on Fig. A.
If the insert is installed as shown on Fig. B breakage of the insert
is inevitable and normal surface finish can not be obtained.

LINEPRO 00036

A

MILLING

Overview

Face milling

Hi-feed milling

Shoulder milling

Profile milling

Hardmill

Center & Chamfer

Spot face

Spare Parts

Technical Data

End Mills

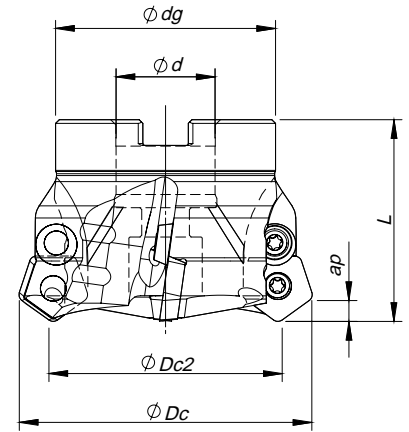
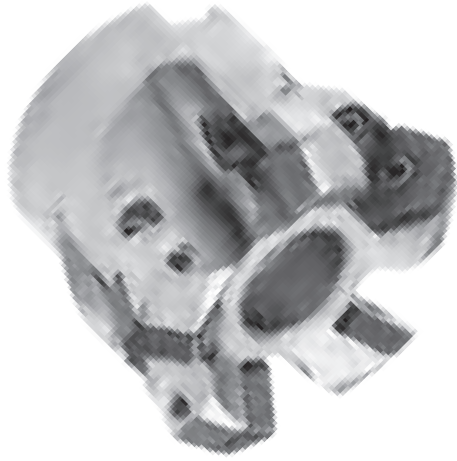

Arbor Mounting

$K_r=36^\circ$ | $\gamma_p=+9^\circ$ | $R_p=7,0$

Order code Código	Reference Referência Referencia		Dimensions Dimensões Dimensiones (mm)					Kg	Specifications		Insert Pastilha Inserto	Stock
			ϕDc	$\phi Dc2$	ϕd	ϕdg	L		Arbor Type	A_p max (mm)		
181009800	066C00036-05-09-027055	5	66	47,5	27	48	55	0,520	A	5,5	PD...1204	
181010400	080C00036-06-09-027055	6	80	61,5	27	60	55	0,940	A	5,5	PD...1204	
181018100	100C00036-07-09-U032055	7	100	81,5	32	70	55	1,400	B	5,5	PD...1204	
181001100	125C00036-08-09-U040055	8	125	106,5	40	90	55	2,420	B	5,5	PD...1204	
181002700	160C00036-09-09-U040055	9	160	141,5	40	120	55	4,590	B	5,5	PD...1204	

Stock item | Produto de stock | Itens de stock

Available under request (see page A-9) | Disponível sobre consulta (consulte a página A-9) | Disponible bajo consulta (mire pagina A-9)

PD... 1204... || Inserts | Pastilhas | Plaquetas

PDMW



PDHW



PDM(H)W

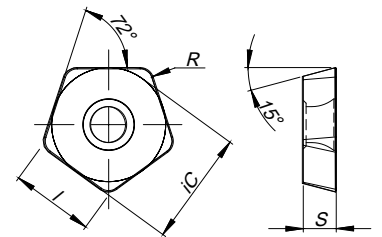

		P			K	Dimensions Dimensões Dimensiones (mm)			
		PVD				PVD	iC	S	I
⁽²⁾ Grade code	68	78	86	68					
⁽¹⁾ Geometry code	ISO Reference	PH6920	PH6125	PH6135	PH6920				
1110555	PDMW 120420 T					16,52	4,76	12,0	2,0
1110554	PDHW 120420 T					16,52	4,76	12,0	2,0

First choice | Primeira opção | 1ª opción

Stock item | Produto de stock | Itens de stock

Available under request (see page A-9) | Disponível sobre consulta (consulte a página A-9) | Disponible bajo consulta (mire pagina A-9)

Insert order code = (1) Geometry Code + (2) Grade Code

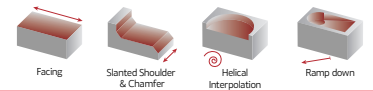

SPARE PARTS | Complementos | Repuestos

ScrewCutter ØDc	Insert Screw	Key (Torx)	Order separately		Order separately	
			Key (Torx - Nm)	Torque Value	Washer	Washer Screw
C00036 – 66-80	P0451001	XT20	DT2050	5,0	HC01200	P0451001
C00036 – 100-160	P0451001	PT20	DT2050	5,0	HC01200	P0451001

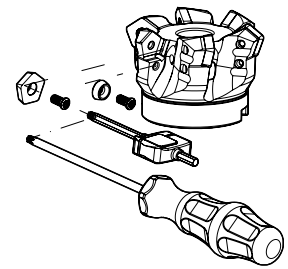

Note: The toolholder is supplied with the XT/PT key. To order the DT key please check the page A-241.
Check the procedures for the clamping screws on the page A-241.

RECOMMENDED CUTTING CONDITIONS | Condições de corte recomendadas | Condiciones de corte recomendables

ISO	PSM	Material	HB (Brinell)	Vc (m/min)			Feed fz (mm/t)
				← Wear Resistance	Toughness →		
				PH6920	PH6125	PH6135	PDHW / PDMW
P	1	Unalloyed Steel	125-220	150-230	160-190	150-180	0,25-0,50
	2	Low-Alloyed Steel	220-280	140-220	140-180	140-170	0,25-0,50
	3	High-Alloyed Steel	280-380	130-180	130-160	120-150	0,25-0,40
K	7	Malleable Cast Iron	130-230	150-280	-	-	0,25-0,60
	8	Grey Cast Iron	180-245	130-230	-	-	0,25-0,60
	9	Nodular Cast iron	160-250	80-190	-	-	0,25-0,60

(Note 1) Cutting conditions ae/DC=70%

(Note 2) Cutting conditions should be adjusted according to the machine and work rigidity.

(Note 3) If chattering occurs, reduce ap and Vc by 30% and keep the same fz per tooth.

RAMPING AND HELICAL INTERPOLATION

Descida em rampa e interpolação helicoidal | Bajada en rampa e interpolación circular

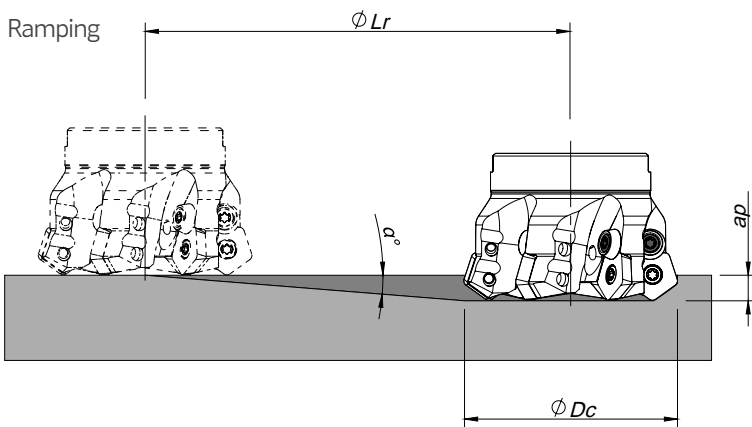

Helical Interpolation

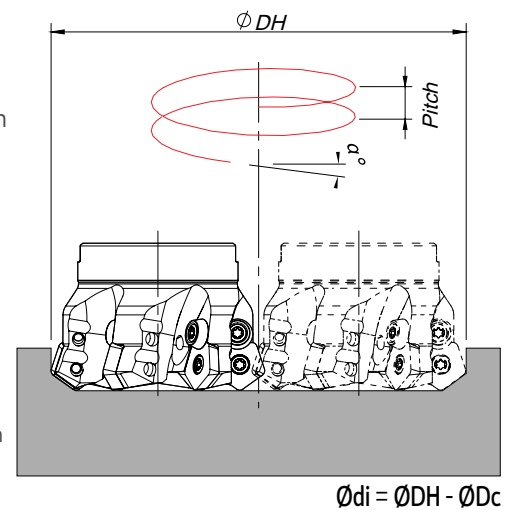

ØDc	Ramping			Helical Interpolation		
	Max Ramp a°	Max ap	Min Lr	ØDHmin	ØDHmax	Max Pitch/Rev.
66	8	5,5	39,1	113,3	-	20,9
				-	130,4	28,4
80	6	5,5	52,3	141,3	-	20,2
				-	158,4	25,9
100	4,3	5,5	73,1	181,3	-	19,2
				-	198,4	23,2
125	3,2	5,5	98,4	231,3	-	18,7
				-	248,4	21,7
160	2,4	5,5	131,2	301,3	-	18,6
				-	318,4	20,8

Note: During helical interpolation do not exceed max Pitch.

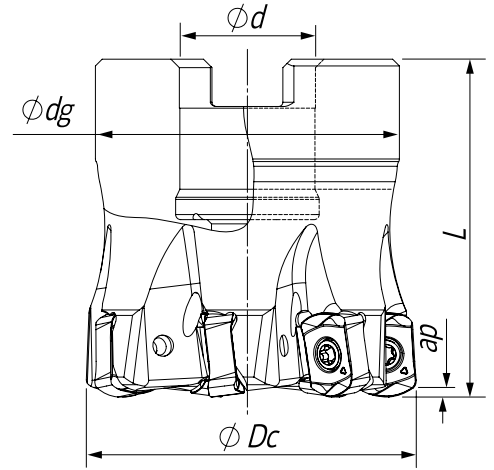
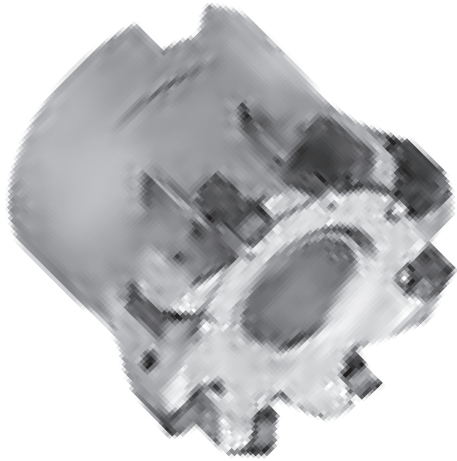

Arbor Mounting
 $K_r=20^\circ$ | $\gamma_p=-7^\circ$ | $Rp=1,8$

Order code Código	Reference Referência Referencia		Dimensions Dimensões Dimensiones (mm)				Kg	Specifications		Insert	Stock
			ϕDc	ϕd	ϕdg	L		Ap max (mm)	Arbor Type		
181152300	040A16320-07-07-016040	7	40	16	36	40	0,20	1,00	A	XNKU 06...	
181157500	050A16320-06-07-022040	6	50	22	42	40	0,25	1,00	A	XNKU 06...	
181152400	050A16320-08-07-022040	8	50	22	42	40	0,29	1,00	A	XNKU 06...	
181152500	052A16320-08-07-022040	8	52	22	40	40	0,39	1,00	A	XNKU 06...	
181152600	063A16320-09-07-022040	9	63	22	48	40	0,50	1,00	A	XNKU 06...	

Stock item | Produto de stock | Itens de stock

Available under request (see page A-9) | Disponível sobre consulta (consulte a página A-9) | Disponible bajo consulta (mire pagina A-9)

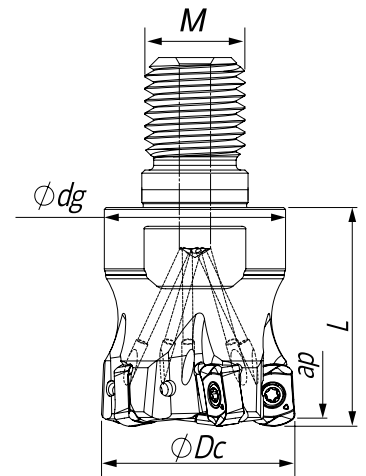

Threaded Coupling
 $K_r=20^\circ$ | $\gamma_p=-7^\circ$ | $Rp=1,8$

Order code Código	Reference Referência Referencia		Dimensions Dimensões Dimensiones (mm)				Kg	Specifications		Insert	Stock
			ϕDc	ϕM	ϕdg	L		Ap max (mm)	Arbor Type		
181151300	016R16320-02-07-M08025	2	16	M08	13	25	0,02	1,00	XNKU 06...		
181151400	020R16320-03-07-M10028	3	20	M10	18	28	0,05	1,00	XNKU 06...		
181151500	025R16320-04-07-M12035	4	25	M12	18	35	0,07	1,00	XNKU 06...		
181148000	032R16320-05-07-M16035	5	32	M16	29	35	0,16	1,00	XNKU 06...		
NEW 181178600	035R16320-05-07-M16035	5	35	M16	29	35	0,16	1,00	XNKU 06...		
181151600	035R16320-06-07-M16035	6	35	M16	29	35	0,17	1,00	XNKU 06...		
181151700	040R16320-05-07-M16045	5	40	M16	29	45	0,24	1,00	XNKU 06...		
NEW 181178500	040R16320-06-07-M16035	6	40	M16	29	35	0,23	1,00	XNKU 06...		
181151800	042R16320-07-07-M16035	7	42	M16	29	35	0,24	1,00	XNKU 06...		

Stock item | Produto de stock | Itens de stock

Available under request (see page A-9) | Disponível sobre consulta (consulte a página A-9) | Disponible bajo consulta (mire pagina A-9)

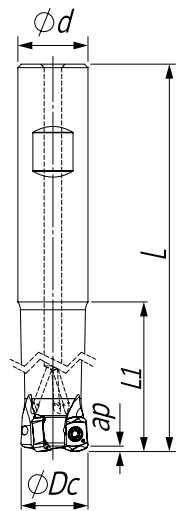
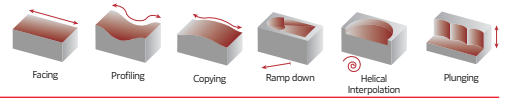

Weldon Shank
 $K_r=20^\circ$ | $\gamma_p=-7^\circ$ | $R_p=1,8$

Order code Código	Reference Referência Referencia		Dimensions Dimensões Dimensiones (mm)				Kg	Specifications		Insert	Stock
			ϕDc	ϕd	L	L1		Ap max (mm)			
181161000	016W16320-02-07-016150	2	16	16	150	50	0,19	1,00	XNKU 06...		
181151900	020W16320-03-07-020160	3	20	20	160	90	0,29	1,00	XNKU 06...		
181152000	025W16320-04-07-025180	4	25	25	180	100	0,40	1,00	XNKU 06...		
181152100	032W16320-05-07-032200	5	32	32	200	120	1,10	1,00	XNKU 06...		

Stock item | Produto de stock | Itens de stock

Available under request (see page A-9) | Disponível sobre consulta (consulte a página A-9) | Disponible bajo consulta (mire pagina A-9)

XNKU 06T3... || Inserts | Pastilhas | Plaquetas

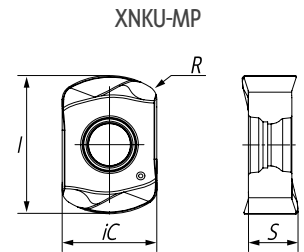

		P				M		K		S		Dimensions Dimensões Dimensiones (mm)			
		CVD	PVD			CVD	PVD	CVD	PVD	CVD	PVD	iC	S	I	R
	⁽²⁾ Grade code	T9	G4	T1	X9	T9	X9	T9	T1	T9	X9				
⁽¹⁾ Geometry code	ISO Reference	PHS740	PHP910	PHP920	PHP930	PHS740	PHH930	PHS740	PHP920	PHS740	PHH930				
NEW 1112802	XNKU 06T310-MP											6,85	3,60	10,00	1,00

First choice | Primeira opção | 1ª opção

Stock item | Produto de stock | Itens de stock

Available under request | Disponível sobre consulta | Disponible bajo consulta

Insert order code = (1) Geometry Code + (2) Grade Code

SPARE PARTS Complementos | Repuestos

Cutter ϕDc	Insert Screw	Key (Torx)	Order separately	
			Key (Torx - Nm)	Torque Value
A16320 - 40-63	P0250704	XT08	DT0812	1,20
R16320 - 20-42	P0250704	XT08	DT0812	1,20
W16320 - 20-32	P0250704	XT08	DT0812	1,20

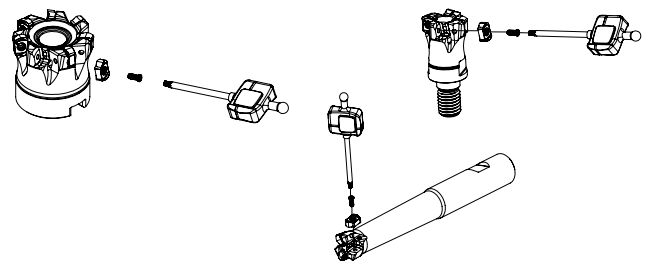

PROGRAMMING DATA | Dados para programação | Datos para la programación

Insert	Programming Data			
	Rp	X	b	ae
XNKU 06T310-MP	1,8	0,4	3,6	3,4

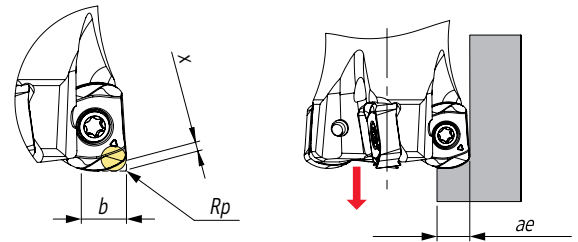

GRADES SELECTION GUIDE | Guia para selecção de graus | Tabla para selección de calidades

ISO	PSM	Material	HB (Brinell)	Grades				
				← Wear Resistance			Toughness →	
				PHP910	PHP920	PHP930	PHH930	PHS740
P	1	Unalloyed Steel	125-220	●	●	●	●	●
	2	Low-Alloyed Steel	220-280	●	●	●	●	●
	3	High-Alloyed Steel	280-380	●	●	●	●	●
M	4	SS - Ferritic / Martensitic	200-330				●	●
	5	SS - Austenitic	200-330				●	●
	6	SS - Austenitic-ferritic (Duplex)	230-260				●	●
K	7	Malleable Cast Iron	130-230	●	●			●
	8	Grey Cast Iron	180-245	●	●			●
	9	Nodular Cast iron	160-250	●	●			●
S	11	Heat Resistant Super Alloys	200-320				●	●

● Good Conditions

● Average Conditions

● Difficult Conditions

RECOMMENDED CUTTING CONDITIONS | Condições de corte recomendadas | Condiciones de corte recomendables

ISO	PSM	Material	HB (Brinell)	Vc (m/min)					Feed fz (mm/t)
				← Wear Resistance			Toughness →		
				PHP910	PHP920	PHP930	PHH930	PHS740	
P	1	Unalloyed Steel	125-220	180-250	180-250	160-230	-	160-230	0,50-1,50
	2	Low-Alloyed Steel	220-280	160-240	170-210	150-190	-	150-190	0,50-1,50
	3	High-Alloyed Steel	280-380	140-230	160-200	140-180	-	140-180	0,50-1,50
M	4	SS - Ferritic / Martensitic	200-330	-	-	-	130-170	120-180	0,50-1,40
	5	SS - Austenitic	200-330	-	-	-	100-160	100-150	0,50-1,40
	6	SS - Austenitic-ferritic (Duplex)	230-260	-	-	-	80-140	70-130	0,50-1,40
K	7	Malleable Cast Iron	130-230	180-300	180-320	-	-	160-300	0,50-1,50
	8	Grey Cast Iron	180-245	160-250	170-280	-	-	150-260	0,50-1,50
	9	Nodular Cast iron	160-250	150-210	100-240	-	-	80-220	0,50-1,50
S	11	Heat Resistant Super Alloys	200-320	-	-	-	30-75	30-70	0,50-1,30

(Note 1) Cutting conditions $a_e/D_c=70\%$.

(Note 2) It's possible to occur vibrations in certain cases. Please reduce depth of cut and / or reduce cutting conditions in following cases:

- When using long shank;
- When using long tool overhang with arbor type;
- When application has poor clamping rigidity or when using a low rigidity machine.

(Note 3) When using $\varnothing D_c=16\text{mm}$ apply 70% or less feed (fz) from the table.



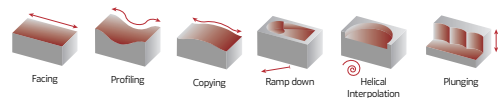

RAMPING AND HELICAL INTERPOLATION

Descida em rampa e interpolação helicoidal | Bajada en rampa e interpolación circular

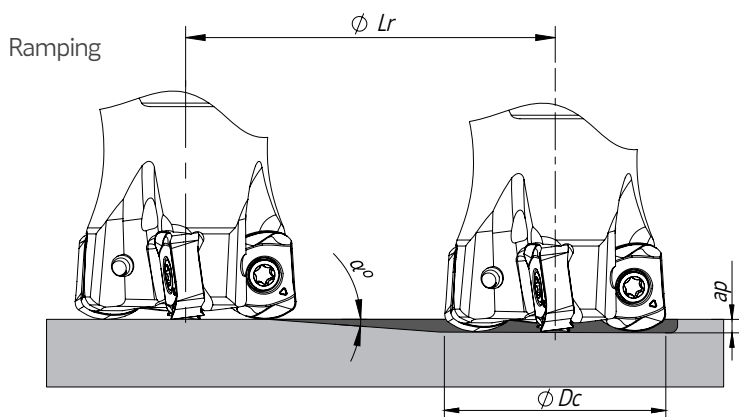

Helical Interpolation

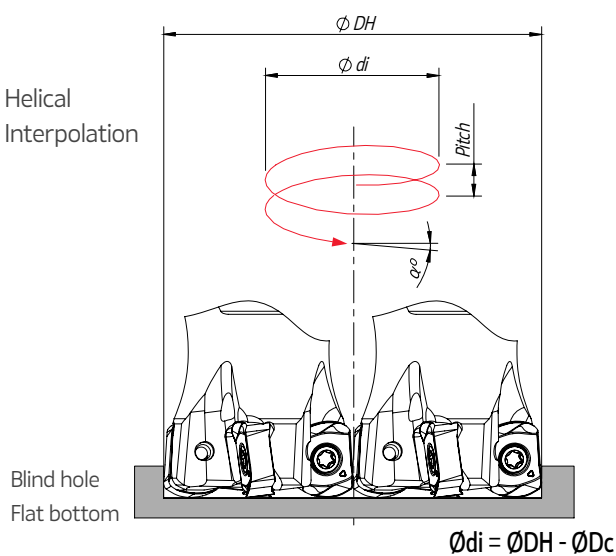

ØDc	Ramping			Helical Interpolation		
	Max Ramp α°	Max a_p	Min Lr	ØDHmin	ØDHmax	Max Pitch/Rev.
16	0,5	1	114,6	24,8	-	0,2
20	0,5	1	114,6	32,8	30,0	0,3
25	0,8	1	71,6	-	38,0	0,4
32	0,8	1	71,6	42,8	-	0,7
35	0,5	1	114,6	-	48,0	1,0
40	0,4	1	143,2	56,8	-	1,0
42	0,4	1	143,2	-	62,0	1,3
50	0,3	1	191,0	62,8	-	0,7
52	0,3	1	191,0	-	68,0	0,9
63	0,25	1	229,2	72,8	-	0,7
				-	78,0	0,8
				76,8	-	0,7
				-	82,0	0,8
				92,8	-	0,7
				-	98,0	0,7
				96,8	-	0,7
				-	102,0	0,8
				118,8	-	0,7
				-	124,0	0,8

Note: During helical interpolation do not exceed max Pitch.
 (*) Down cutting is recommended, tool pass rotation should be counter-clockwise.
 (*) In case of ramping and helical interpolation, apply 70% or less feed (fz) from recommended cutting conditions table.

PLUNGING | Mergulho | Plunge

L ≤ 3Dc	L > 3Dc	S max.
fz (mm/t)		
0,08-0,15	0,05 - 0,10	$S_{max} = \sqrt{DC \cdot Dr - Dr^2}$

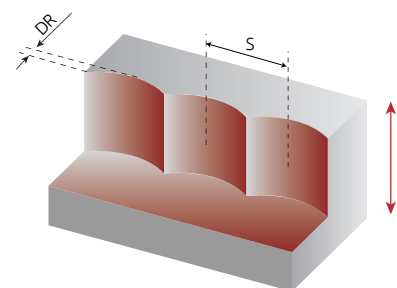

S max and DR corresponding cutting diameter Dc (mm)										
DR (mm)	Dc (mm) XNKU 06...									
	16	20	25	32	35	40	42	50	52	60
1	3,9	4,4	4,9	5,6	5,8	6,2	6,4	7,0	7,1	7,9
2	5,3	6,0	6,8	7,7	8,1	8,7	8,9	9,8	10,0	11,0
3	6,2	7,1	8,1	9,3	9,8	10,5	10,8	11,9	12,1	13,4

Note: Recommended for L ≤ 4 Dc for extra long tool this step and side cut must be reduced.

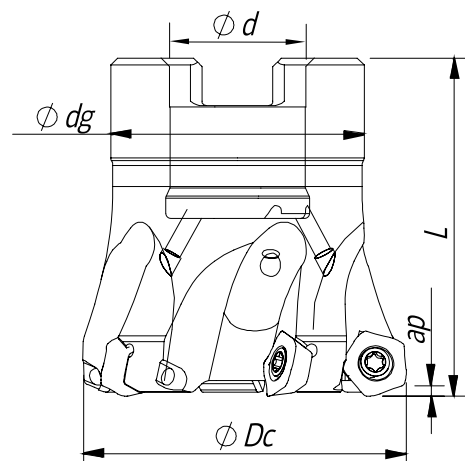
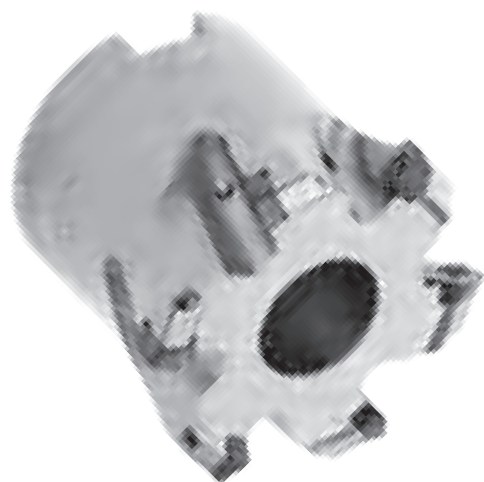

Arbor Mounting
 $K_r=20^\circ$ | $\gamma_p=14^\circ$ | $R_p=2,5$

Order code Código	Reference Referência Referencia		Dimensions Dimensões Dimensiones (mm)				Kg	Specifications		Insert	Stock
			ϕDc	ϕd	ϕdg	L		A_p max (mm)	Arbor Type		
181129300	040A06320-05-14-016040	5	40	16	30	40	0,15	1,0	A	POKT 0403...	
181129400	050A06320-06-14-022045	6	50	22	40	45	0,19	1,0	A	POKT 0403...	
181129500	052A06320-06-14-022045	6	52	22	40	45	0,29	1,0	A	POKT 0403...	
181129600	063A06320-07-14-027050	7	63	27	48	50	0,50	1,0	A	POKT 0403...	
181131300	066A06320-07-14-027050	7	66	27	48	50	0,55	1,0	A	POKT 0403...	

Stock item | Produto de stock | Itens de stock

Available under request (see page A-9) | Disponível sobre consulta (consulte a página A-9) | Disponible bajo consulta (mire pagina A-9)

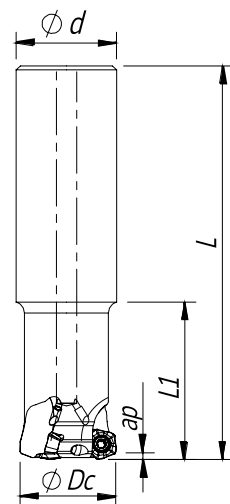

Cylindrical Shank
 $K_r=20^\circ$ | $\gamma_p=14^\circ$ | $R_p=2,5$

Order code Código	Reference Referência Referencia		Dimensions Dimensões Dimensiones (mm)				Kg	Specifications		Insert	Stock
			ϕDc	ϕd	L	L1		A_p max (mm)	Arbor Type		
181147200	020E06320-02-14-020130	2	20	20	130	40	0,38	1,0	A	POKT 0403...	
181131000	025E06320-03-14-025150	3	25	25	150	40	0,41	1,0	A	POKT 0403...	
181131100	032E06320-05-14-032180	5	32	32	180	50	0,56	1,0	A	POKT 0403...	
181131200	040E06320-05-14-032180	5	40	32	180	50	0,70	1,0	A	POKT 0403...	

Stock item | Produto de stock | Itens de stock

Available under request (see page A-9) | Disponível sobre consulta (consulte a página A-9) | Disponible bajo consulta (mire pagina A-9)

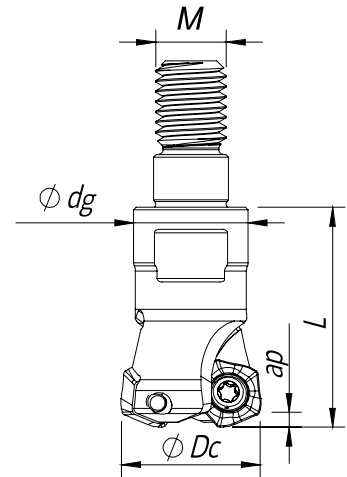
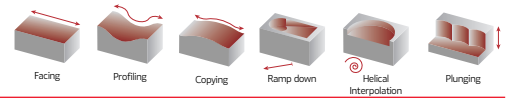

Threaded Coupling
 $K_r=20^\circ$ | $\gamma_p=14^\circ$ | $R_p=2,5$

Order code Código	Reference Referência Referencia		Dimensions Dimensões Dimensiones (mm)				Kg	Specifications		Insert	Stock
			ϕDc	ϕM	ϕdg	L		A_p max (mm)			
181113500	016R06320-02-14-M08025	2	16	M08	13	25	0,02	1,0	POKT 0403...		
181113600	020R06320-02-14-M10025	2	20	M10	18	25	0,05	1,0	POKT 0403...		
181113700	025R06320-03-14-M12028	3	25	M12	21	28	0,07	1,0	POKT 0403...		
181129100	032R06320-05-14-M16035	5	32	M16	29	35	0,17	1,0	POKT 0403...		
181129200	035R06320-05-14-M16035	5	35	M16	29	35	0,19	1,0	POKT 0403...		
181130900	042R06320-05-14-M16035	5	42	M16	29	35	0,23	1,0	POKT 0403...		

Stock item | Produto de stock | Itens de stock

Available under request (see page A-9) | Disponível sobre consulta (consulte a página A-9) | Disponible bajo consulta (mire pagina A-9)

POKT 0403... || Inserts | Pastilhas | Plaquetas

POKT-MP



POKT-MP

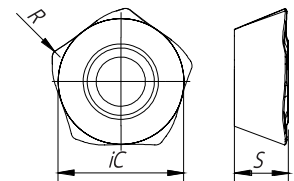

	⁽²⁾ Grade code	P				K		Dimensions Dimensões Dimensiones (mm)		
		PVD				PVD				
		G1	G4	P3	G6	G1	G4	iC	S	R
⁽¹⁾ Geometry code	ISO Reference	PH7910	PH7920	PH7930	PH7740	PH7910	PH7920			
1112365	POKT 040305 ZDSR-MP							7,00	3,00	0,50

First choice | Primeira opção | 1ª opción

Stock item | Produto de stock | Itens de stock

Available under request (see page A-9) | Disponível sobre consulta (consulte a página A-9) | Disponible bajo consulta (mire pagina A-9)

Insert order code = (1) Geometry Code + (2) Grade Code

PENTA HIFEED 06320

SPARE PARTS Complementos | Repuestos

Cutter ØDc	Insert Screw	Key (Torx)	Order separately		Order separately	
			Key (Torx - Nm)	Torque Value	Screw	DIN 6368 Wrench
R06320 - 16-42	P0250503	XT08	DT0812	1,20	-	-
E06320 - 25-40	P0250503	XT08	DT0812	1,20	-	-
A06320 - 40-60	P0250503	XT08	DT0812	1,20	-	-

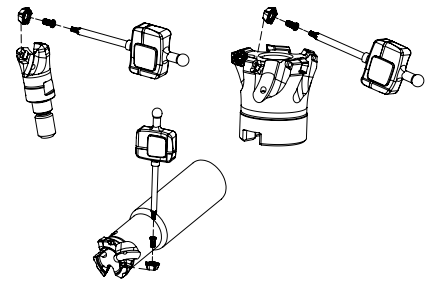

Note: The toolholder is supplied with the XT/PT key. To order the DT key please check the page A-241.
Check the procedures for the clamping screws on the page A-241.

GRADES SELECTION GUIDE | Guia para selecção de graus | Tabla para selección de calidades

ISO	PSM	Material	HB (Brinell)	Grades			
				← Wear Resistance			Toughness →
				PH7910	PH7920	PH7930	PH7740
P	1	Unalloyed Steel	125-220	●	●	●	●
	2	Low-Alloyed Steel	220-280	●	●	●	●
	3	High-Alloyed Steel	280-380	●	●	●	●
K	7	Malleable Cast Iron	130-230	●	●		
	8	Grey Cast Iron	180-245	●	●		
	9	Nodular Cast iron	160-250	●	●		

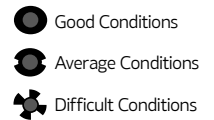

RECOMMENDED CUTTING CONDITIONS | Condições de corte recomendadas | Condiciones de corte recomendables

ISO	PSM	Material	HB (Brinell)	Vc (m/min)				Feed fz (mm/t)
				← Wear Resistance			Toughness →	
				PH7910	PH7920	PH7930	PH7740	
P	1	Unalloyed Steel	125-220	180-250	180-240	160-220	140-200	0,50-1,50
	2	Low-Alloyed Steel	220-280	160-230	160-220	140-200	130-180	0,50-1,51
	3	High-Alloyed Steel	280-380	140-220	140-210	120-190	100-170	0,50-1,52
K	7	Malleable Cast Iron	130-230	180-300	160-260	-	-	0,50-1,53
	8	Grey Cast Iron	180-245	160-250	140-240	-	-	0,50-1,54
	9	Nodular Cast iron	160-250	150-200	120-200	-	-	0,50-1,55

(Note 1) Cutting conditions $a_e/D_c=70\%$.

(Note 2) It's possible to occur vibrations in certain cases. Please reduce depth of cut and / or reduce cutting conditions in following cases:

- When using long shank;
- When using long tool overhang with arbor type;
- When application has poor clamping rigidity or when using a low rigidity machine.

(Note 3) PH5... and PHS... can be used wet or dry. PH7... use only air.

PROGRAMMING DATA | Dados para programação | Datos para la programación

Insert	Programming Data			
	Rp	X	b	a_e
POKT 0403...	2,5	1,2	4,3	4,0

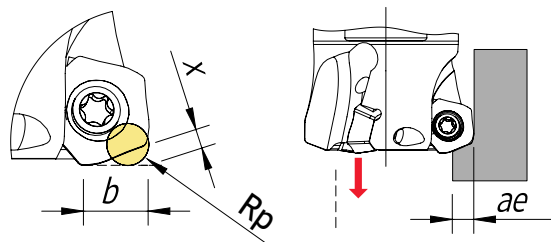

RAMPING AND HELICAL INTERPOLATION

Descida em rampa e interpolação helicoidal | Bajada en rampa e interpolación circular

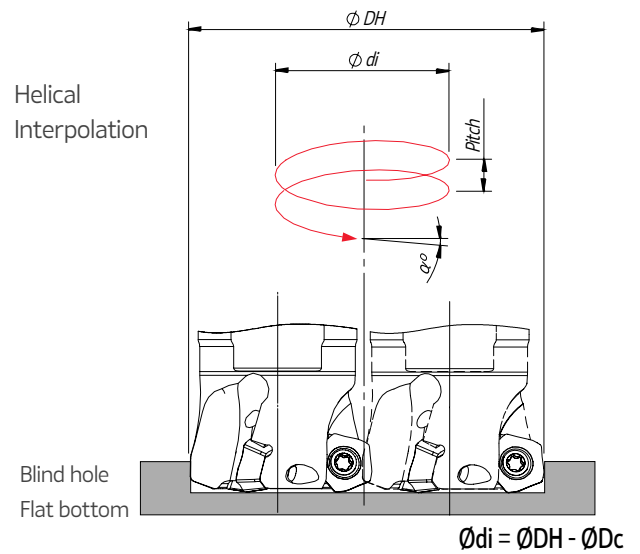
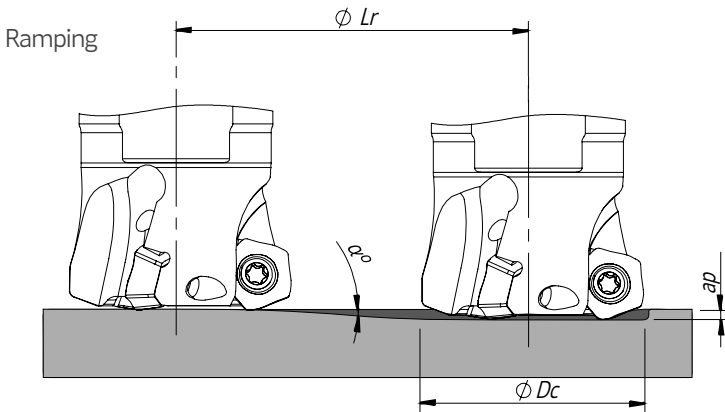

ØDc	Ramping			Helical Interpolation		
	Max Ramp α°	Max ap	Min Lr	ØDHmin	ØDHmax	Max Pitch/Rev.
16	15	1,0	3,7	23,4	-	6
				-	30,0	11
20	9,0	1,0	6,3	31,4	-	5
				-	38,0	8
25	5,0	1,0	11,4	41,4	-	4
				-	48,0	6
32	3,4	1,0	16,8	55,4	-	4
				-	62,0	5
35	3,0	1,0	19,1	61,4	-	4
				-	68,0	5
40	2,0	1,0	28,6	71,4	-	3
				-	78,0	4
42	2,0	1,0	28,6	84,0	-	4
				-	82,0	4
50	2,0	1,0	28,6	91,4	-	4
				-	98,0	5
52	2,0	1,0	28,6	95,4	-	4
				-	102,0	5
63	2,0	1,0	28,6	117,4	-	5
				-	124,0	6
66	1,8	1,0	31,8	123,4	-	5
				-	130,0	6

Note: During helical interpolation do not exceed max Pitch.

PLUNGING | Mergulho | Plunge

L ≤ 3Dc	L > 3Dc	S max.
fz (mm/t)		
0,08-0,15	0,05 - 0,10	$S_{max} = \sqrt{Dc \cdot Dr - Dr^2}$

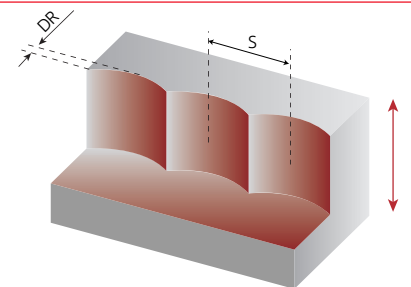

S max and DR corresponding cutting diameter Dc (mm)											
DR (mm)	Dc (mm) POKT 04...										
	16	20	25	32	35	40	42	50	52	63	66
1,0	3,9	4,4	4,9	5,7	5,8	6,2	6,4	7,0	7,1	7,9	8,1
2,0	5,3	6,0	6,8	7,7	8,1	8,7	8,9	9,8	10,0	11,0	11,3
3,0	6,2	7,1	8,1	9,3	9,8	10,5	10,8	11,9	12,1	13,4	13,7
4,0	6,9	8,0	9,2	10,6	11,1	12,0	12,3	13,6	13,9	15,4	15,7

Note: Recommended for L ≤ 4 Dc for extra long tool this step and side cut must be reduced.

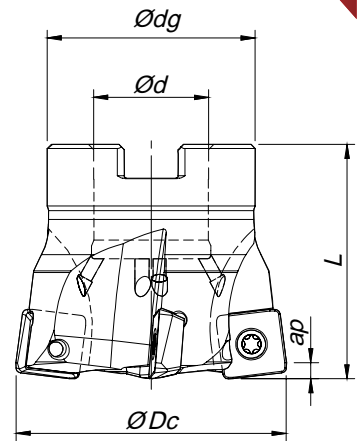
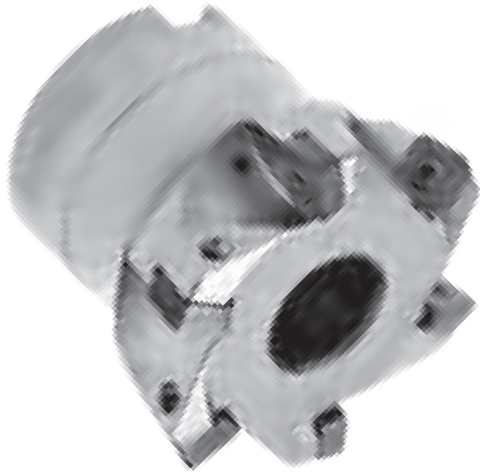

Arbor Mounting

$K_r=10^\circ$ | $\gamma_p=+2^\circ$ | $\gamma_f=+2^\circ$ | $R_p=2,0$

Order code Código	Reference Referência Referencia		Dimensions Dimensões Dimensiones (mm)				Kg	Specifications		Insert Pastilha Inserto	Stock
			$\varnothing Dc$	$\varnothing d$	$\varnothing dg$	L		Ap max (in)	Arbor Type		
181149800	040A06410-05-02-016040		40	16	30	40	0,157	1,00	A	SO...0803...	
181153200	050A06410-06-02-022045		50	22	40	45	0,312	1,00	A	SO...0803...	
181149900	052A06410-06-02-022045		52	22	40	45	0,331	1,00	A	SO...0803...	

Stock item | Produto de stock | Itens de stock

Available under request | Disponível sobre consulta | Disponible bajo consulta

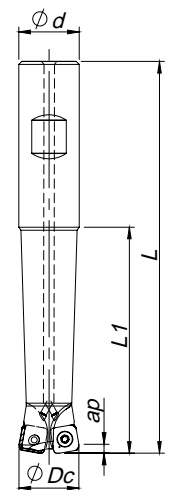

Weldon Shank

$K_r=10^\circ$ | $\gamma_p=+2^\circ$ | $\gamma_f=+2^\circ$ | $R_p=2,0$

Order code Código	Reference Referência Referencia		Dimensions Dimensões Dimensiones (mm)				Kg	Specifications		Insert Pastilha Inserto	Stock
			$\varnothing Dc$	$\varnothing d$	L	L1		Ap max (mm)	Arbor Type		
181076300	020W06410-02-02-020130		20	20	130	75	0,360	1,00	SO...0803...		
181080900	020W06410-02-02-020190		20	20	190	110	0,340	1,00	SO...0803...		
181076400	025W06410-03-02-025140		25	25	140	80	0,410	1,00	SO...0803...		
181081100	025W06410-03-02-025200		25	25	200	130	0,570	1,00	SO...0803...		
181076500	032W06410-04-02-032150		32	32	150	90	0,760	1,00	SO...0803...		
181081300	032W06410-04-02-032200		32	32	200	130	1,010	1,00	SO...0803...		

Stock item | Produto de stock | Itens de stock

Available under request | Disponível sobre consulta | Disponible bajo consulta

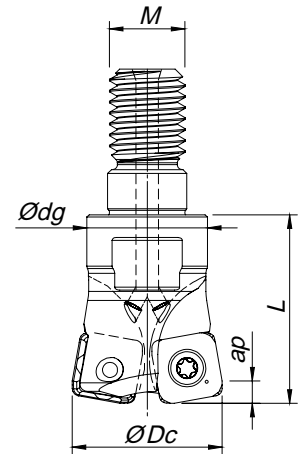
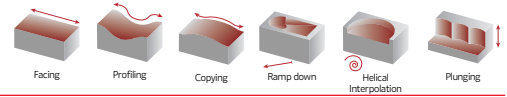

Threaded Coupling

$K_r=10^\circ$ | $\gamma_p=+2^\circ$ | $\gamma_f=+2^\circ$ | $R_p=2,0$

Order code Código	Reference Referência Referencia		Dimensions Dimensões Dimensiones (mm)				Kg	Specifications	Insert Pastilha Inserto	Stock
			ØDc	ØM	Ødg	L		Ap max (mm)		
181071900	020R06410-02-02-M10025		20	M10	16	25	0,040	1,00	SO...0803...	
181076600	025R06410-03-02-M12028		25	M12	21	28	0,070	1,00	SO...0803...	
181076700	032R06410-04-02-M16035		32	M16	29	35	0,160	1,00	SO...0803...	
181076800	035R06410-04-02-M16035		35	M16	29	35	0,180	1,00	SO...0803...	
181076900	042R06410-05-02-M16035		42	M16	29	35	0,220	1,00	SO...0803...	

Stock item | Produto de stock | Itens de stock

Available under request | Disponível sobre consulta | Disponible bajo consulta

SO...0803... || Inserts | Pastilhas | Plaquetas

SOEW



SOET



SOEW

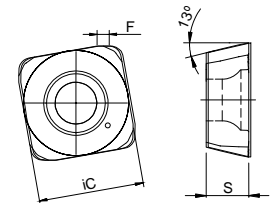

SOET

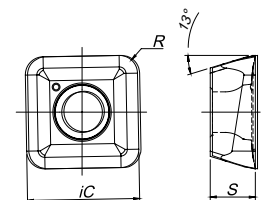

Geometry code	ISO Reference	P			M		K			S		Dimensions Dimensões Dimensiones (mm)			
		PVD			PVD		PVD			PVD		iC	S	R	F
		X5	T1	G6	X9	G6	X5	T1	G6	X9	G6				
⁽¹⁾		PH910	PH920	PH7740	PH930	PH7740	PH910	PH920	PH7740	PH930	PH7740				
1111884	SOEW 080310 S											8,60	3,47	1,0	1,0
1112149	SOET 080315-MS											8,60	3,47	1,5	-

First choice | Primeira opção | 1ª opción

Stock item | Produto de stock | Itens de stock

Available under request | Disponível sobre consulta | Disponible bajo consulta

Insert order code = (1) Geometry Code + (2) Grade Code

HIFEED 06410

A

SPARE PARTS | Complementos | Repuestos

MILLING

Cutter ØDc	Insert Screw	Key (Torx)	Order separately	
			Key (Torx - Nm)	Torque Value
A06410 - 40 - 52	P0300800	XT09	DT0914	1,4
R06410 - 20 - 42	P0300800	XT09	DT0914	1,4
W06410 - 20 - 32	P0300800	XT09	DT0914	1,4

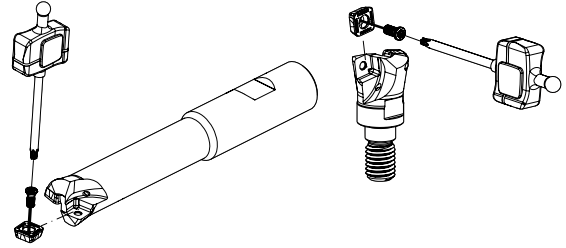

Overview

Face milling

PROGRAMMING DATA | Dados para programação | Datos para la programación

Insert	Programming Data			
	Rp	X	b	ae
SO... 0803..	2,0	0,8	6,8	6,3

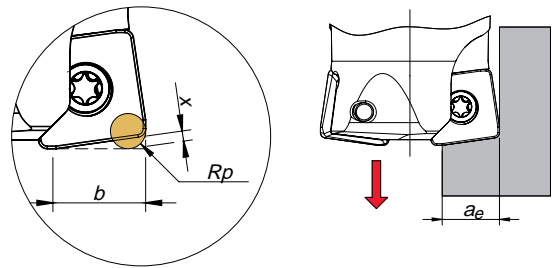

Hifeed milling

Shoulder milling

Profile milling

GRADES SELECTION GUIDE | Guia para selecção de graus | Tabla para selección de calidades

ISO	PSM	Material	HB (Brinell)	Grades			
				← Wear Resistance		Toughness →	
				PHP910	PHP920	PHH930	PH7740
P	1	Unalloyed Steel	125-220	●	●	●	●
	2	Low-Alloyed Steel	220-280	✓	✓		✓
	3	High-Alloyed Steel	280-380	✓	✓		✓
M	4	SS - Ferritic / Martensitic	200-330			✓	✓
	5	SS - Austenitic	200-330			✓	✓
	6	SS - Austenitic-ferritic (Duplex)	230-260			✓	✓
K	7	Malleable Cast Iron	130-230	✓	✓		
	8	Grey Cast Iron	180-245	✓	✓		
	9	Nodular Cast iron	160-250	✓	✓		
S	11	Heat Resistant Super Alloys	200-320			✓	✓

- Good Conditions
- Average Conditions
- Difficult Conditions

Spot face

Spare Parts

Technical Data

End Mills

RECOMMENDED CUTTING CONDITIONS | Condições de corte recomendadas | Condiciones de corte recomendables

ISO	PSM	Material	HB (Brinell)	Vc (m/min)				Feed fz (mm/t)	
				← Wear Resistance		Toughness →		SOEW 08...	SOET 08...
				PHP910	PHP920	PHH930	PH7740		
P	1	Unalloyed Steel	125-220	180-250	180-250	-	140-200	0,40-1,80	0,40-1,80
	2	Low-Alloyed Steel	220-280	160-240	160-230	-	130-180	0,40-1,80	-
	3	High-Alloyed Steel	280-380	140-230	140-220	-	100-170	0,40-1,50	-
M	4	SS - Ferritic / Martensitic	200-330	-	-	140-210	130-180	-	0,40-1,30
	5	SS - Austenitic	200-330	-	-	120-170	110-160	-	0,40-1,30
	6	SS - Austenitic-ferritic (Duplex)	230-260	-	-	100-150	90-150	-	0,10-1,00
K	7	Malleable Cast Iron	130-230	180-300	160-270	-	-	0,40-1,80	0,40-1,80
	8	Grey Cast Iron	180-245	160-250	140-250	-	-	0,40-1,80	-
	9	Nodular Cast iron	160-250	150-210	120-210	-	-	0,40-1,80	-
S	11	Heat Resistant Super Alloys	200-320			30-110	30-100	-	0,40-1,00

(Note 1) Cutting conditions $a_e/D_c=70\%$.

(Note 2) It's possible to occur vibrations in certain cases. Please reduce depth of cut and / or reduce cutting conditions in following cases:

- When using long shank;
- When using long tool overhang with arbor type;
- When application has poor clamping rigidity or when using a low rigidity machine.

(Note 3) PH5... and PH8... can be used wet or dry. PH7... use only air.

(Note 4) It's possible to occur vibrations in certain cases. Please reduce depth of cut and / or reduce cutting conditions in following cases:

- When using long shank;
- When using long tool overhang with arbor type;
- When application has poor clamping rigidity or when using a low rigidity machine.

CHIP-BREAKER SELECTION GUIDE | Guia para aplicações do quebra- aparas | Guía para aplicación del rompevirutas

ISO	PSM	Material	HB (Brinell)	Chip-Breaker Application	
				1st choice	Difficult Operations
P	1	Unalloyed Steel	125-220	SOET 08...	SOEW 08...
	2	Low-Alloyed Steel	220-280	SOEW 08...	-
	3	High-Alloyed Steel	280-380	SOEW 08...	-
M	4	SS - Ferritic / Martensitic	200-330	SOET 08...	-
	5	SS - Austenitic	200-330	SOET 08...	-
	6	SS - Austenitic-ferritic (Duplex)	230-260	SOET 08...	-
K	7	Malleable Cast Iron	130-230	SOET 08...	SOEW 08...
	8	Grey Cast Iron	180-245	SOEW 08...	-
	9	Nodular Cast iron	160-250	SOEW 08...	-
S	11	Heat Resistant Super Alloys	200-320	SOET 08...	-

HIFEED 06410

RAMPING AND HELICAL INTERPOLATION

Descida em rampa e interpolação helicoidal | Bajada en rampa e interpolación circular

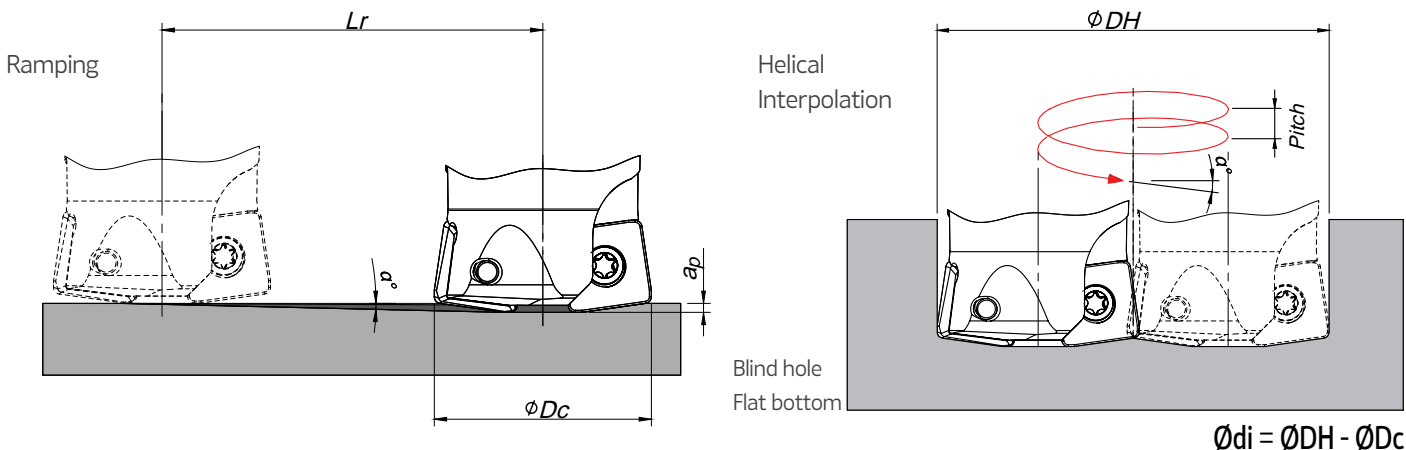

ØDc	Ramping			Helical Interpolation		
	Max Ramp a°	Max ap	Min Lr	ØDHmin	ØDHmax	Max Pitch/Rev.
20	15	1,0	3,2	26,4 -	- 38,0	6 17
25	9,5	1,0	6,0	36,4 -	- 48,0	5 12
32	5,5	1,0	10,4	50,4 -	- 62,0	5 9
35	4,5	1,0	12,7	56,4 -	- 68,0	5 8
40	3,5	1,0	16,3	66,4 -	- 80,0	5 7
42	3,5	1,0	16,3	70,4 -	- 82,0	5 7
50	3,5	1,0	16,3	86,4 -	- 100,0	6 9
52	3,5	1,0	16,3	90,4 -	- 104,0	7 9

Note: During helical interpolation do not exceed max Pitch.

PLUNGING | Mergulho | Plunge

L ≤ 3Dc	L > 3Dc	S max.
f _z (mm/t)		
0,08-0,15	0,05-0,10	$S_{max} = \sqrt{D_c \cdot DR \cdot DR^2}$

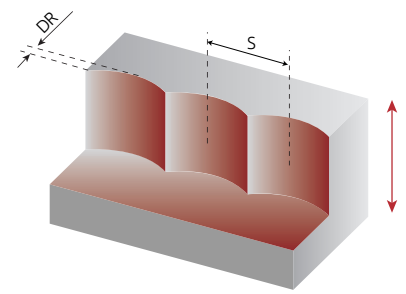

S max and DR corresponding cutting diameter Dc (mm)								
DR (mm)	Dc (mm)							
	20	25	32	35	40	42	50	52
1,0	4,4	4,9	5,6	5,8	6,2	6,4	7,0	7,1
2,0	6,0	6,8	7,7	8,1	8,7	8,9	9,8	10,0
3,0	7,1	8,1	9,3	9,8	10,5	10,8	11,9	12,1
4,0	8,0	9,2	10,6	11,1	12,0	12,3	13,6	13,9
5,0	8,7	10,0	11,6	12,2	13,2	13,6	15,0	15,3
6,0	9,2	10,7	12,5	13,2	14,3	14,7	16,2	16,6

Note: Recommended for L ≤ 4 Dc for extra long tool this step and side cut must be reduced.



A

MILLING

Overview

Face milling

Hifeed milling

Shoulder milling

Profile milling

Hardmill

Center & Chamfer

Spot face

Spare Parts

Technical Data

End Mills

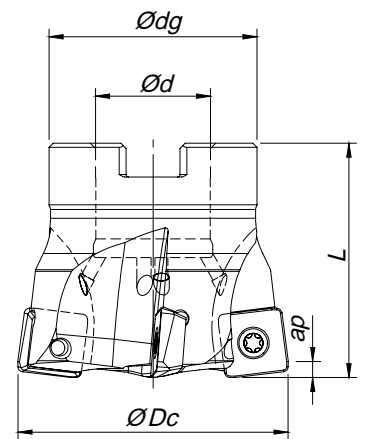
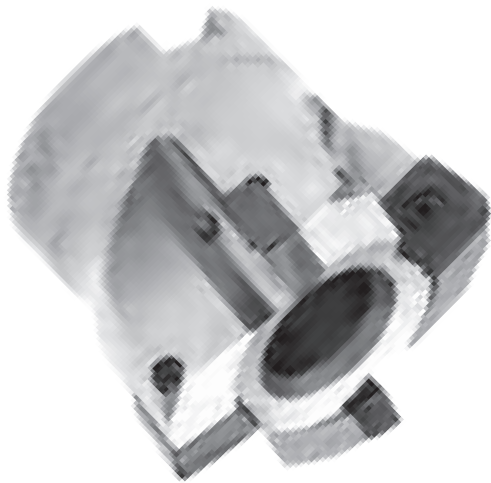

Arbor Mounting

$K_r=10^\circ$ | $\gamma_p=+5^\circ$ | $R_p=2,5$

Order code Código	Reference Referência Referencia		Dimensions Dimensões Dimensiones (mm)				Kg	Specifications		Insert Pastilha Inserto	Stock
			ØDc	Ød	Ødg	L		Ap max (mm)	Arbor Type		
181069100	050A06690-04-05-022045	4	50	22	40	45	0,274	1,50	A	SO...13M5...	
181111100	050A06690-05-05-022045	5	50	22	40	45	0,272	1,50	A	SO...13M5...	
181029800	052A06690-04-05-022045	4	52	22	40	45	0,290	1,50	A	SO...13M5...	
181033500	063A06690-05-05-027050	5	63	27	48	50	0,500	1,50	A	SO...13M5...	
181029900	066A06690-05-05-027050	5	66	27	48	50	0,550	1,50	A	SO...13M5...	
181030000	080A06690-06-05-027050	6	80	27	60	50	0,955	1,50	A	SO...13M5...	
181113100	100A06690-08-05-032050	8	100	32	70	50	1,500	1,50	A	SO...13M5...	

Stock item | Produto de stock | Itens de stock

Available under request (see page A-9) | Disponível sobre consulta (consulte a página A-9) | Disponible bajo consulta (mire pagina A-9)

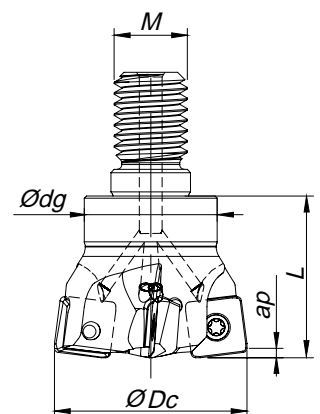

Threaded Coupling

$K_r=10^\circ$ | $\gamma_p=+5^\circ$ | $R_p=2,5$

Order code Código	Reference Referência Referencia		Dimensions Dimensões Dimensiones (mm)				Kg	Specifications		Insert Pastilha Inserto	Stock
			ØDc	ØM	Ødg	L		Ap max (mm)	Arbor Type		
181038700	032R06690-03-05-M16035	3	32	M16	29	35	0,145	1,50	SO...13M5		
181064600	035R06690-03-05-M16035	3	35	M16	29	35	0,163	1,50	SO...13M5		
181038800	042R06690-04-05-M16035	4	42	M16	29	35	0,194	1,50	SO...13M5		

Stock item | Produto de stock | Itens de stock

Available under request (see page A-9) | Disponível sobre consulta (consulte a página A-9) | Disponible bajo consulta (mire pagina A-9)

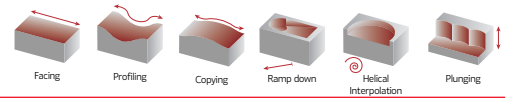

SO...13M5... || Inserts | Pastilhas | Plaquetas

SOEW

SOEW-MD **NEW**



SOEW | SOEW-MD

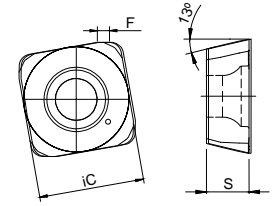

SOET



SOET

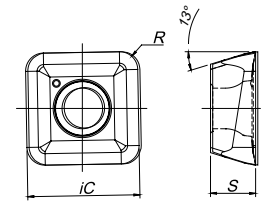

(1) Geometry code	(2) Grade code	P			M			K			S		Dimensions Dimensões Dimensiones (mm)			
		PVD			PVD			PVD			PVD		iC	S	R	F
		X5	T1	G6	P3	X9	G6	X5	T1	G6	X9	G6				
1111906	SOEW 13M510 S	⊗	⊗	⊗				⊗	⊗	⊗			12,43	5,00	1,20	1,0
1112813	SOEW 13M510-MD		⊗						⊗				12,43	5,00	1,20	1,0
1112147	SOET 13M520-MS			⊗	⊗	⊗	⊗			⊗	⊗	⊗	12,43	5,00	2,0	-

⊗ First choice | Primeira opção | 1ª opción ⊗ Stock item | Produto de stock | Itens de stock ○ Available under request (see page A-9) | Disponível sobre consulta (consulte a página A-9) | Disponible bajo consulta (mire página A-9) Insert order code = (1) Geometry Code + (2) Grade Code
 ⊕ Stock available until sold out | Stock disponível até acabar o stock | Stock disponible hasta acabar el stock

SPARE PARTS || Complementos | Repuestos

Cutter ØDc	Order separately				
	Insert Screw	Key (Torx)	Key (Torx - Nm)	Torque Value	Retaining Screw
R06690 - 32 - 42	P0401200	XT15	DT1530	3	-
A06690 - 50 - 80	P0401200	XT15	DT1530	3	-
A06690 - 100	P0401200	XT15	DT1530	3	D1603500

Note: The toolholder is supplied with the XT/PT key. To order the DT key please check the page A-241.
Check the procedures for the clamping screws on the page A-241.

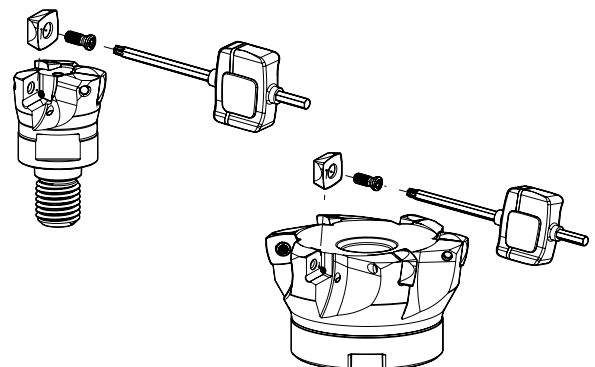

HIFEED 06690

GRADES SELECTION GUIDE | Guia para selecção de graus | Tabla para selección de calidades

ISO	PSM	Material	HB (Brinell)	Grades			
				← Wear Resistance			Toughness →
				PHP910	PHP920	PHH930	PH7740
P	1	Unalloyed Steel	125-220	●	●	●	●
	2	Low-Alloyed Steel	220-280	●	●		●
	3	High-Alloyed Steel	280-380	●	●		●
M	4	SS - Ferritic / Martensitic	200-330			●	●
	5	SS - Austenitic	200-330			●	●
	6	SS - Austenitic-ferritic (Duplex)	230-260			●	●
K	7	Malleable Cast Iron	130-230	●	●		●
	8	Grey Cast Iron	180-245	●	●		●
	9	Nodular Cast iron	160-250	●	●		●
S	11	Heat Resistant Super Alloys	200-320			●	●

- Good Conditions
- Average Conditions
- Difficult Conditions

RECOMMENDED CUTTING CONDITIONS | Condições de corte recomendadas | Condiciones de corte recomendables

ISO	PSM	Material	HB (Brinell)	Vc (m/min)				Feed fz (mm/t)		
				← Wear Resistance			Toughness →			
				PHP910	PHP920	PHH930	PH7740	SOEW S	SOEW MD	SOET MS
P	1	Unalloyed Steel	125-220	180-250	180-250	-	140-200	0,50-2,10	0,50-2,20	0,50-2,10
	2	Low-Alloyed Steel	220-280	160-240	160-230	-	130-180	0,50-2,10	0,50-2,20	-
	3	High-Alloyed Steel	280-380	140-230	140-220	-	100-170	0,50-2,00	0,50-2,10	-
M	4	SS - Ferritic / Martensitic	200-330	-	-	140-210	130-180	-	-	0,50-1,80
	5	SS - Austenitic	200-330	-	-	120-170	110-160	-	-	0,50-1,80
	6	SS - Austenitic-ferritic (Duplex)	230-260	-	-	100-150	90-150	-	-	0,50-1,50
K	7	Malleable Cast Iron	130-230	180-300	160-270	-	140-220	0,50-2,10	0,50-2,20	0,50-2,10
	8	Grey Cast Iron	180-245	160-250	140-250	-	120-210	0,50-2,10	0,50-2,20	-
	9	Nodular Cast iron	160-250	150-210	120-210	-	100-190	0,50-2,10	0,50-2,20	-
S	11	Heat Resistant Super Alloys	200-320	-	-	30-110	30-100	-	-	0,40-1,30

(Note 1) Cutting conditions $a_e/D_c=70\%$.

(Note 2) It's possible to occur vibrations in certain cases. Please reduce depth of cut and / or reduce cutting conditions in following cases:

- When using long shank;
- When using long tool overhang with arbor type;
- When application has poor clamping rigidity or when using a low rigidity machine.

(Note 3) It's possible to occur vibrations in certain cases. Please reduce depth of cut and / or reduce cutting conditions in following cases:

- When using long shank;
- When using long tool overhang with arbor type;
- When application has poor clamping rigidity or when using a low rigidity machine.

CHIP-BREAKER SELECTION GUIDE | Guia para aplicações do quebra- aparas | Guía para aplicación del rompevirutas

ISO	PSM	Material	HB (Brinell)	Chip-Breaker Application	
				1st choice	Difficult Operations
P	1	Unalloyed Steel	125-220	SOEW-MD	SOEW-S
	2	Low-Alloyed Steel	220-280	SOEW-MD	SOEW-S
	3	High-Alloyed Steel	280-380	SOEW-MD	SOEW-S
M	4	SS - Ferritic / Martensitic	200-330	SOET-MS	-
	5	SS - Austenitic	200-330	SOET-MS	-
	6	SS - Austenitic-ferritic (Duplex)	230-260	SOET-MS	-
K	7	Malleable Cast Iron	130-230	SOET-MS	SOEW-S
	8	Grey Cast Iron	180-245	SOEW-MD	SOEW-S
	9	Nodular Cast iron	160-250	SOEW-MD	SOEW-S
S	11	Heat Resistant Super Alloys	200-320	SOET-MS	-

PROGRAMMING DATA | Dados para programação | Datos para la programación

Insert	Programming Data			
	Rp	X	b	ae
SO... 13M5..	2,5	1,1	10,5	10,0

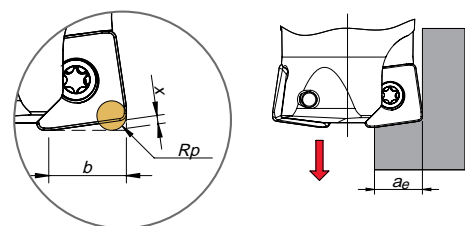

HIFEEED 06690

RAMPING AND HELICAL INTERPOLATION

Descida em rampa e interpolação helicoidal | Bajada en rampa e interpolación circular

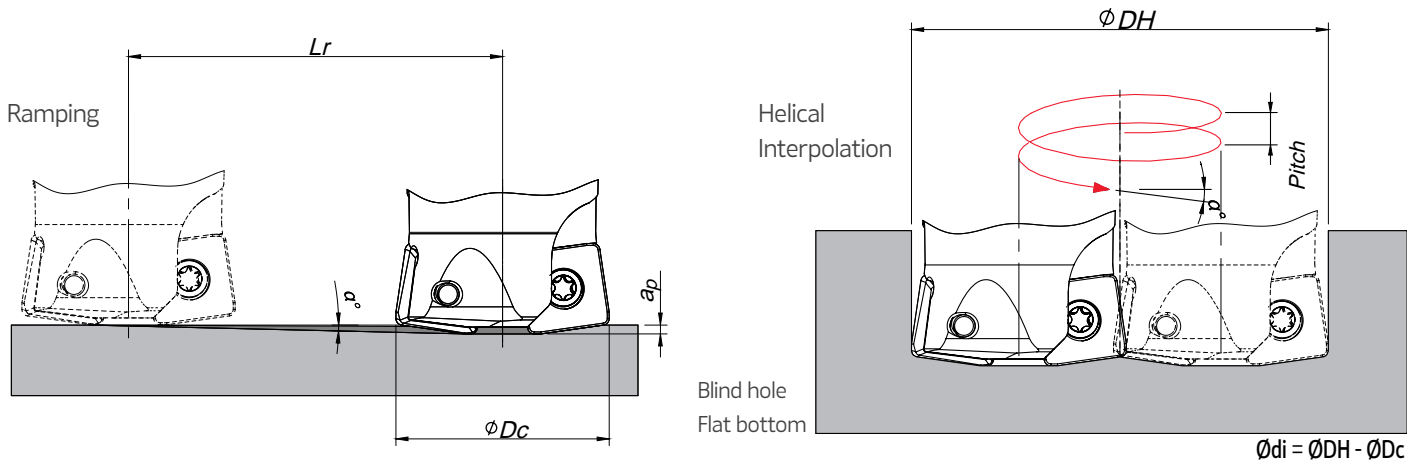

ϕDc	Ramping			Helical Interpolation		
	Max Ramp a°	Max a_p	Min L_r	ϕDH_{min}	ϕDH_{max}	Max Pitch/Rev.
32	10,0	1,5	6,0	43 -	- 62,0	6 16
35	9,0	1,5	9,5	49 -	- 68,0	6 16
42	6,4	1,5	13,4	63 -	- 82,0	7 14
50	4,3	1,5	19,9	79 -	- 98,0	6 11
52	4,0	1,5	21,5	83 -	- 102,0	6 10
63	3,0	1,5	28,6	105 -	- 124,0	6 10
66	2,6	1,5	33,0	111 -	- 130,0	6 9
80	2,0	1,5	43,0	139 -	- 158,0	6 8
100	1,0	1,5	85,9	179 -	- 198,0	4 5

Note: During helical interpolation do not exceed max Pitch.

PLUNGING | Mergulho | Plunge

L ≤ 3Dc	L > 3Dc	S max.
f _z (mm/t)		
0,10-0,20	0,07-0,14	$S_{max} = \sqrt{D_c \cdot DR - DR^2}$

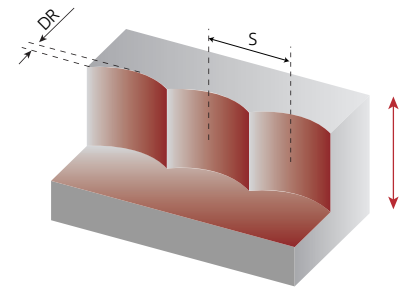

S max and DR corresponding cutting diameter Dc (mm)									
DR (mm)	Dc (mm)								
	32	35	42	50	52	63	66	80	
1,0	5,6	5,8	6,4	7,0	7,1	7,9	8,1	8,9	
2,0	7,7	8,1	8,9	9,8	10,0	11,0	11,3	12,5	
3,0	9,3	9,8	10,8	11,9	12,1	13,4	13,7	15,2	
4,0	10,6	11,1	12,3	13,6	13,9	15,4	15,7	17,4	
5,0	11,6	12,2	13,6	15,0	15,3	17,0	17,5	19,4	
6,0	12,5	13,2	14,7	16,2	16,6	18,5	19,0	21,1	
7,0	13,2	14,0	15,7	17,3	17,7	19,8	20,3	22,6	
8,0	13,9	14,7	16,5	18,3	18,8	21,0	21,5	24,0	
9,0	14,4	15,3	17,2	19,2	19,7	22,0	22,6	25,3	
10,0	14,8	15,8	17,9	20,2	20,5	23,0	23,7	26,5	

Note: Recommended for L ≤ 4 Dc for extra long tool this step and side cut must be reduced.



A

MILLING

Overview

Face milling

Hifeed milling

Shoulder milling

Profile milling

Hardmill

Center & Chamfer

Spot face

Spare Parts

Technical Data

End Mills

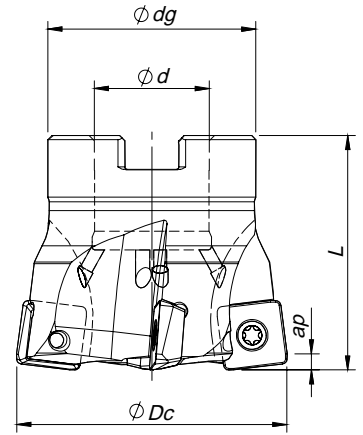
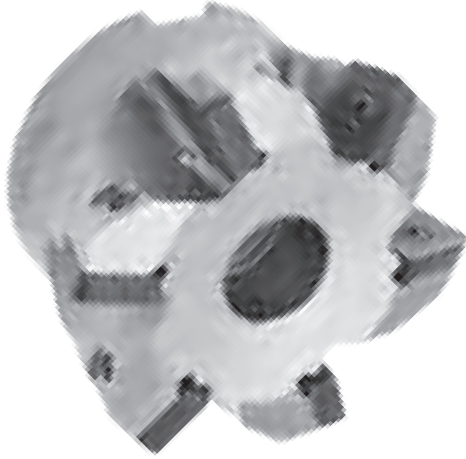

Arbor Mounting

$$\kappa_r = 15^\circ \mid \gamma_p = +2^\circ \mid R_p = 4,5$$

Order code Código	Reference Referência Referencia		Dimensions Dimensões Dimensiones (mm)				Kg	Specifications		Insert Pastilha Inserto	Stock
			ϕDc	ϕd	ϕdg	L		Ap max (mm)	Arbor Type		
181100400	063A06815-05-02-027050		63	27	48	50	0,460	3,50	A	SO...1605...	
181081900	066A06815-05-02-027050		66	27	48	50	0,500	3,50	A	SO...1605...	
181082000	080A06815-06-02-027050		80	27	60	50	0,900	3,50	A	SO...1605...	
181082100	100A06815-08-02-032050		100	32	80	50	1,600	3,50	B	SO...1605...	
181082200	125A06815-10-02-040063		125	40	90	63	2,900	3,50	B	SO...1605...	
181082300	160A06815-12-02-U040063		160	40	110	63	4,400	3,50	C	SO...1605...	

Stock item | Produto de stock | Itens de stock

Available under request (see page A-9) | Disponível sobre consulta (consulte a página A-9) | Disponible bajo consulta (mire pagina A-9)

SO...1605... || Inserts | Pastilhas | Plaquetas

SOEW



SOEW

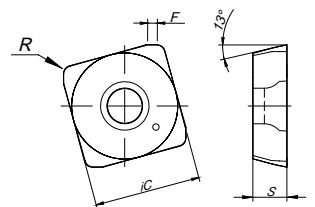

SOET



SOET

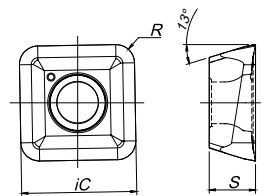

(1) Geometry code	ISO Reference	P					M			K					S		Dimensions Dimensões Dimensiones (mm)			
		PVD					PVD			PVD					PVD					
		(2) Grade code	X5	G1	T1	G4	G6	X9	P3	G6	X5	G1	T1	G4	G6	X9	G6	iC	S	R
1111907	SOEW 160512 S																16,40	5,26	1,20	1,50
1112221	SOET 160520-MS																16,40	5,26	2,00	-

First choice | Primeira opção | 1ª opción

Stock item | Produto de stock | Itens de stock

Available under request (see page A-9) | Disponível sobre consulta (consulte a página A-9) | Disponible bajo consulta (mire pagina A-9)

Insert order code = (1) Geometry Code + (2) Grade Code

Stock available until sold out | Stock disponível até acabar o stock | Stock disponible hasta acabar el stock

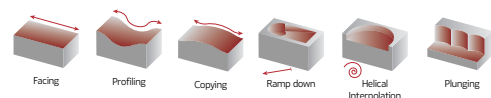

SPARE PARTS | Complementos | Repuestos

Cutter ØDc	Insert Screw	Key (Torx)	Order separately		Order separately	
			Key (Torx - Nm)	Torque Value	Screw	DIN 6368 Wrench
A06815 - 63-80	P0501302	PT20	DT2050	5,0	-	-
A06815 - 100	P0501302	PT20	DT2050	5,0	J0123510	SD6368-12
A06815 - 125	P0501302	PT20	DT2050	5,0	J0164110	SD6368-16
A06815 - 160	P0501302	PT20	DT2050	5,0	-	-

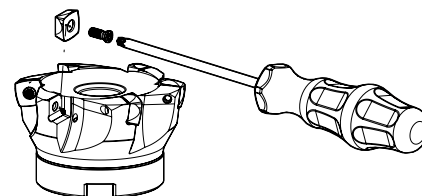

Note: The toolholder is supplied with the XT/PT key. To order the DT key please check the page A-241.
Check the procedures for the clamping screws on the page A-241.

GRADES SELECTION GUIDE | Guia para seleção de graus | Tabla para selección de calidades

ISO	PSM	Material	HB (Brinell)	Grades			
				← Wear Resistance		Toughness →	
				PHP910	PHP920	PHH930	PH7740
P	1	Unalloyed Steel	125-220	●	●		●
	2	Low-Alloyed Steel	220-280	●	●		●
	3	High-Alloyed Steel	280-380	●	●		●
M	4	SS - Ferritic / Martensitic	200-330			●	●
	5	SS - Austenitic	200-330			●	●
	6	SS - Austenitic-ferritic (Duplex)	230-260			●	●
K	7	Malleable Cast Iron	130-230	●	●		●
	8	Grey Cast Iron	180-245	●	●		●
	9	Nodular Cast iron	160-250	●	●		●
S	11	Heat Resistant Super Alloys	200-320			●	●

● Good Conditions
● Average Conditions
● Difficult Conditions

RECOMMENDED CUTTING CONDITIONS | Condições de corte recomendadas | Condiciones de corte recomendables

ISO	PSM	Material	HB (Brinell)	Vc (m/min)				Feed fz (mm/t)	
				← Wear Resistance		Toughness →		SOEW S...	SOET MS...
				PHP910	PHP920	PHH930	PH7740		
P	1	Unalloyed Steel	125-220	180-250	180-250	-	140-200	0,50-2,10	0,50-2,20
	2	Low-Alloyed Steel	220-280	160-240	160-230	-	130-180	0,50-2,10	0,50-2,20
	3	High-Alloyed Steel	280-380	140-230	140-220	-	100-170	0,50-2,00	0,50-1,80
M	4	SS - Ferritic / Martensitic	200-330	-	-	140-210	130-180	-	0,50-1,80
	5	SS - Austenitic	200-330	-	-	120-170	110-160	-	0,50-1,80
	6	SS - Austenitic-ferritic (Duplex)	230-260	-	-	100-150	90-150	-	0,50-1,50
K	7	Malleable Cast Iron	130-230	180-300	160-270	-	140-220	0,50-2,10	0,50-2,00
	8	Grey Cast Iron	180-245	160-250	140-250	-	120-210	0,50-2,10	0,50-2,00
	9	Nodular Cast iron	160-250	150-210	120-210	-	100-190	0,50-2,10	0,50-1,80
S	11	Heat Resistant Super Alloys	200-320	-	-	30-110	30-100	-	0,40-1,30

(Note 1) Cutting conditions $a_e/D_c=70\%$.

(Note 2) It's possible to occur vibrations in certain cases. Please reduce depth of cut and / or reduce cutting conditions in following cases:
- When using long shank;
- When using long tool overhang with arbor type;
- When application has poor clamping rigidity or when using a low rigidity machine.

(Note 3) PH5... and PH8... can be used wet or dry. PH7... use only air.

(Note 4) It's possible to occur vibrations in certain cases. Please reduce depth of cut and / or reduce cutting conditions in following cases:
- When using long shank;
- When using long tool overhang with arbor type;
- When application has poor clamping rigidity or when using a low rigidity machine.

CHIP-BREAKER SELECTION GUIDE | Guia para aplicações do quebra- aparas | Guía para aplicación del rompevirutas

ISO	PSM	Material	HB (Brinell)	Chip-Breaker Application	
				1st choice	Difficult Operations
P	1	Unalloyed Steel	125-220	SOET 16...	SOEW 16...
	2	Low-Alloyed Steel	220-280	SOEW 16...	-
	3	High-Alloyed Steel	280-380	SOEW 16...	-
M	4	SS - Ferritic / Martensitic	200-330	SOET 16...	-
	5	SS - Austenitic	200-330	SOET 16...	-
	6	SS - Austenitic-ferritic (Duplex)	230-260	SOET 16...	-
K	7	Malleable Cast Iron	130-230	SOET 16...	SOEW 16...
	8	Grey Cast Iron	180-245	SOEW 16...	-
	9	Nodular Cast iron	160-250	SOEW 16...	-
S	11	Heat Resistant Super Alloys	200-320	SOET 16...	-

PROGRAMMING DATA | Dados para programação | Datos para la programación

Insert	Programming Data			
	Rp	X	b	ae
SO... 1605..	4,5	2,3	13,5	12,8

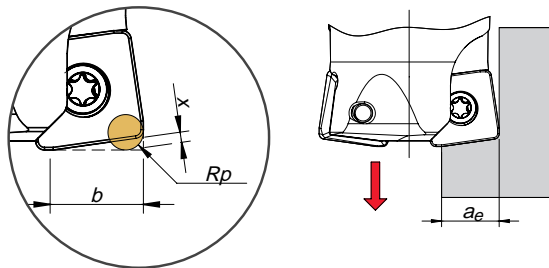

RAMPING AND HELICAL INTERPOLATION

Descida em rampa e interpolação helicoidal | Bajada en rampa e interpolación circular

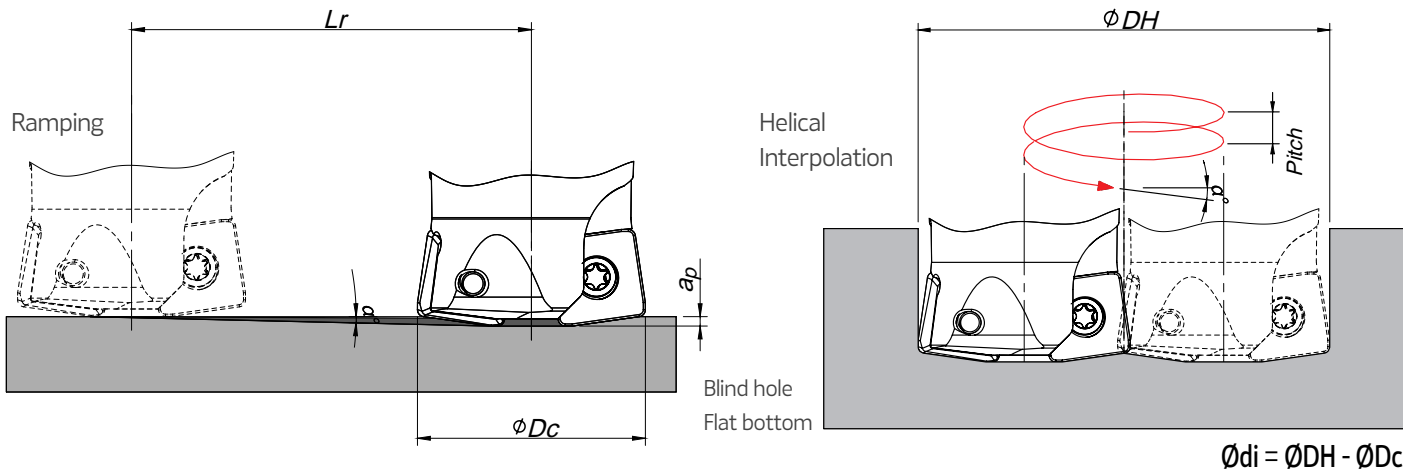

$$\text{Ødi} = \text{ØDH} - \text{ØDc}$$

ØDc	Ramping			Helical Interpolation		
	Max Ramp a°	Max ap	Min Lr	ØDHmin	ØDHmax	Max Pitch/Rev.
63	3,5	3,5	80,2	99,0	-	6
66	3,0	3,5	66,8	105	-	6
				-	123,6	10
80	2,0	3,5	100,2	133	-	5
				-	129,6	8
100	1,5	3,5	133,7	173	-	6
				-	157,5	8
125	1,0	3,5	200,5	223	-	5
				-	197,5	6
160	0,5	3,5	401,1	293	-	3
				-	247,5	4
				-	317,5	

Note: During helical interpolation do not exceed max Pitch.

PLUNGING | Mergulho | Plunge

$L \leq 3D_c$	$L > 3D_c$	S max.
f_z (mm/t)		
0,10-0,20	0,07-0,14	$S_{max} = \sqrt{D_c \cdot DR - DR^2}$

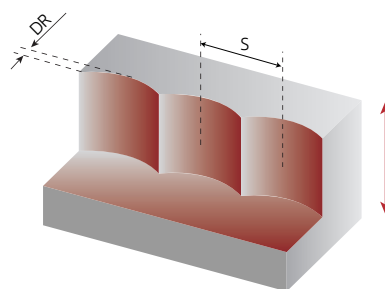

S max and DR corresponding cutting diameter Dc (mm)		
DR (mm)	Dc (mm)	
	66	80
1,0	8,1	8,9
2,0	11,3	12,5
3,0	13,7	15,2
4,0	15,7	17,4
5,0	17,5	19,4
6,0	19,0	21,1
7,0	20,3	22,6
8,0	21,5	24,0
9,0	22,6	25,3
10,0	23,7	26,5
11,0	24,6	27,5
12,0	25,5	28,6

Note: Recommended for $L \leq 4 D_c$ for extra long tool this step and side cut must be reduced.



HIFEED 50560

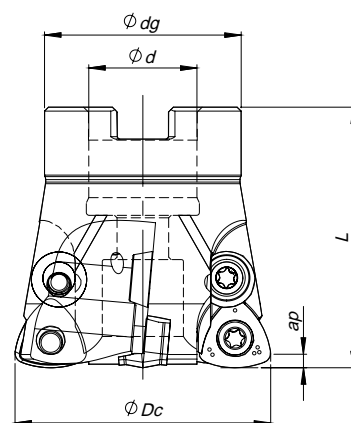

Arbor Mounting

$\gamma_p = +5^\circ$ | $R_p = 3,2$

Order code Código	Reference Referência Referencia		Dimensions Dimensões Dimensiones (mm)				Kg	Specifications		Insert Pastilha Inserto	Stock
			ϕDc	ϕd	ϕdg	L		A_p max (mm)	Arbor Type		
181020800	052C50560-04-05-022053	4	52	22	40	53	0,390	1,5	A	WD... 1204...	
181020200	066C50560-05-05-027053	5	66	27	48	53	0,640	1,5	A	WD... 1204...	
181020300	080C50560-06-05-027053	6	80	27	60	53	1,060	1,5	A	WD... 1204...	
181172400	063C50560-05-05-027053	5	63	27	48	53	0,59	1,5	A	WD... 1204...	

Stock item | Produto de stock | Itens de stock

Available under request (see page A-9) | Disponível sobre consulta (consulte a página A-9) | Disponible bajo consulta (mire pagina A-9)

SPARE PARTS | Complementos | Repuestos

ScrewCutter ϕDc	Insert Screw	Key (Torx)	Order separately		Order separately	
			Key (Torx - Nm)	Torque Value	Washer	Washer Screw
A50560 - 52 - 80						
	P0451001	XT20	DT2050	5,0	HC01200	P0451001

Note: The toolholder is supplied with the XT/PT key. To order the DT key please check the page A-241.
Check the procedures for the clamping screws on the page A-241.

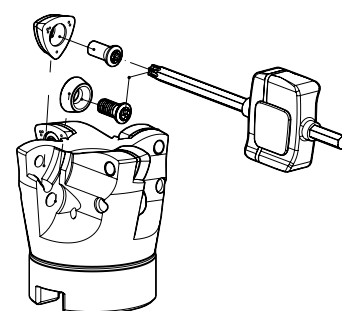

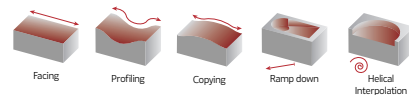

WD... 1204... | Inserts | Pastilhas | Plaquetas

WDET

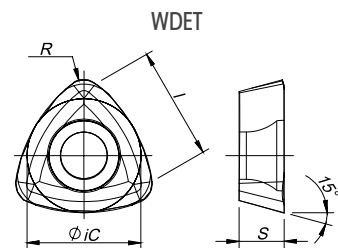

WDMW

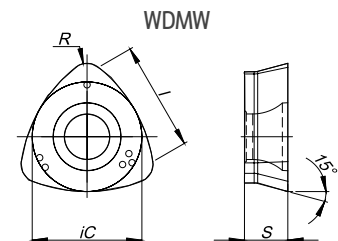

	(2) Grade code	P			M		K		S		Dimensions Dimensões Dimensiones (mm)			
		PVD			PVD		PVD		PVD					
(1) Geometry code	ISO Reference	G4	P3	G6	P3	G6	G4	G6	P3	G6	iC	S	I	R
1112148	WDET 120420-MS		⊗	⊗	⊗	⊗			⊗	⊗	12,00	4,76	11,9	2,00
1111123	WDMW 120420-T	⊗		⊗			⊗	⊗			12,00	4,76	11,9	2,00

⊗ First choice | Primeira opção | 1ª opción ⊗ Stock item | Produto de stock | Itens de stock ○ Available under request (see page A-9) | Disponível sobre consulta (consulte a página A-9) | Disponible bajo consulta (mire página A-9) Insert order code = (1) Geometry Code + (2) Grade Code

GRADES SELECTION GUIDE | Guia para selecção de graus | Tabla para selección de calidades

ISO	PSM	Material	HB (Brinell)	Grades			
				← Wear Resistance		Toughness →	
				PH7910	PH7920	PH7930	PH7740
P	1	Unalloyed Steel	125-220	●	●	●	●
	2	Low-Alloyed Steel	220-280	✓	✓	✓	✓
	3	High-Alloyed Steel	280-380	✓	✓	✓	✓
M	4	SS - Ferritic / Martensitic	200-330			✓	✓
	5	SS - Austenitic	200-330			✓	✓
	6	SS - Austenitic-ferritic (Duplex)	230-260			✓	✓
K	7	Malleable Cast Iron	130-230	✓	✓	✓	✓
	8	Grey Cast Iron	180-245	✓	✓	✓	✓
	9	Nodular Cast iron	160-250	✓	✓	✓	✓
S	11	Heat Resistant Super Alloys	200-320			✓	✓

● Good Conditions
● Average Conditions
● Difficult Conditions

A
MILLING
Overview
Face milling
Hifeed milling
Shoulder milling
Profile milling
Hardmill
Center & Chamfer
Spot face
Spare Parts
Technical Data
End Mills

HIFEED 50560

RECOMMENDED CUTTING CONDITIONS | Condições de corte recomendadas | Condiciones de corte recomendables

ISO	PSM	Material	HB (Brinell)	Vc (m/min)				Feed fz (mm/t)	
				← Wear Resistance		Toughness →		WDMW 12...	WDET 12...
				PH7910	PH7920	PH7930	PH7740		
P	1	Unalloyed Steel	125-220	180-250	180-240	160-220	140-200	0,30-1,50	0,30-1,30
	2	Low-Alloyed Steel	220-280	160-230	160-220	140-200	130-180	0,30-1,50	0,30-1,30
	3	High-Alloyed Steel	280-380	140-220	140-210	120-190	100-170	0,30-1,30	0,30-1,00
M	4	SS - Ferritic / Martensitic	200-330			140-200	130-180	-	0,30-1,30
	5	SS - Austenitic	200-330			120-160	110-160	-	0,30-1,30
	6	SS - Austenitic-ferritic (Duplex)	230-260			100-140	90-150	-	0,30-1,00
K	7	Malleable Cast Iron	130-230	180-300	160-260		140-220	0,30-1,50	-
	8	Grey Cast Iron	180-245	160-250	140-240		120-210	0,30-1,50	-
	9	Nodular Cast iron	160-250	150-200	120-200		100-190	0,30-1,40	-
S	11	Heat Resistant Super Alloys	200-320	-	-	30-100	30-100	-	0,30-1,00

(Note 1) Cutting conditions $a_e/D_c=70\%$.

(Note 2) It's possible to occur vibrations in certain cases. Please reduce depth of cut and / or reduce cutting conditions in following cases:

- When using long shank;
- When using long tool overhang with arbor type;
- When application has poor clamping rigidity or when using a low rigidity machine.

(Note 3) PH5... and PHS... can be used wet or dry. PH7... use only air.

(Note 4) It's possible to occur vibrations in certain cases. Please reduce depth of cut and / or reduce cutting conditions in following cases:

- When using long shank;
- When using long tool overhang with arbor type;
- When application has poor clamping rigidity or when using a low rigidity machine.

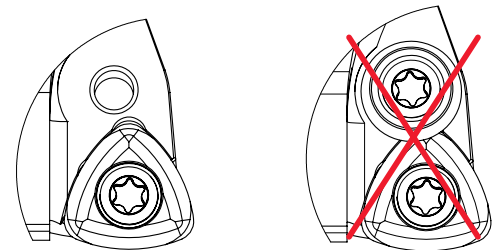

When using WDET insert, please remove the washer and the washer screw, otherwise it will break the insert.

CHIP-BREAKER SELECTION GUIDE | Guia para aplicações do quebra- aparas | Guía para aplicación del rompevirutas

ISO	PSM	Material	HB (Brinell)	Chip-Breaker Application	
				1st choice	Difficult Operations
P	1	Unalloyed Steel	125-220	WDET 12...	WDMW 12...
	2	Low-Alloyed Steel	220-280	WDMW 12...	-
	3	High-Alloyed Steel	280-380	WDMW 12...	-
M	4	SS - Ferritic / Martensitic	200-330	WDET 12...	-
	5	SS - Austenitic	200-330	WDET 12...	-
	6	SS - Austenitic-ferritic (Duplex)	230-260	WDET 12...	-
K	7	Malleable Cast Iron	130-230	WDMW 12...	-
	8	Grey Cast Iron	180-245	WDMW 12...	-
	9	Nodular Cast iron	160-250	WDMW 12...	-
S	11	Heat Resistant Super Alloys	200-320	WDET 12...	-

PROGRAMMING DATA | Dados para programação | Datos para la programación

Insert	Programming Data			
	Rp	x	b	a _e
WD...1204	3,2	0,7	7,2	7,0

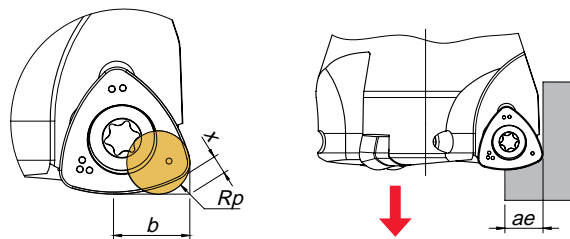

RAMPING AND HELICAL INTERPOLATION

Descida em rampa e interpolação helicoidal | Bajada en rampa e interpolación circular

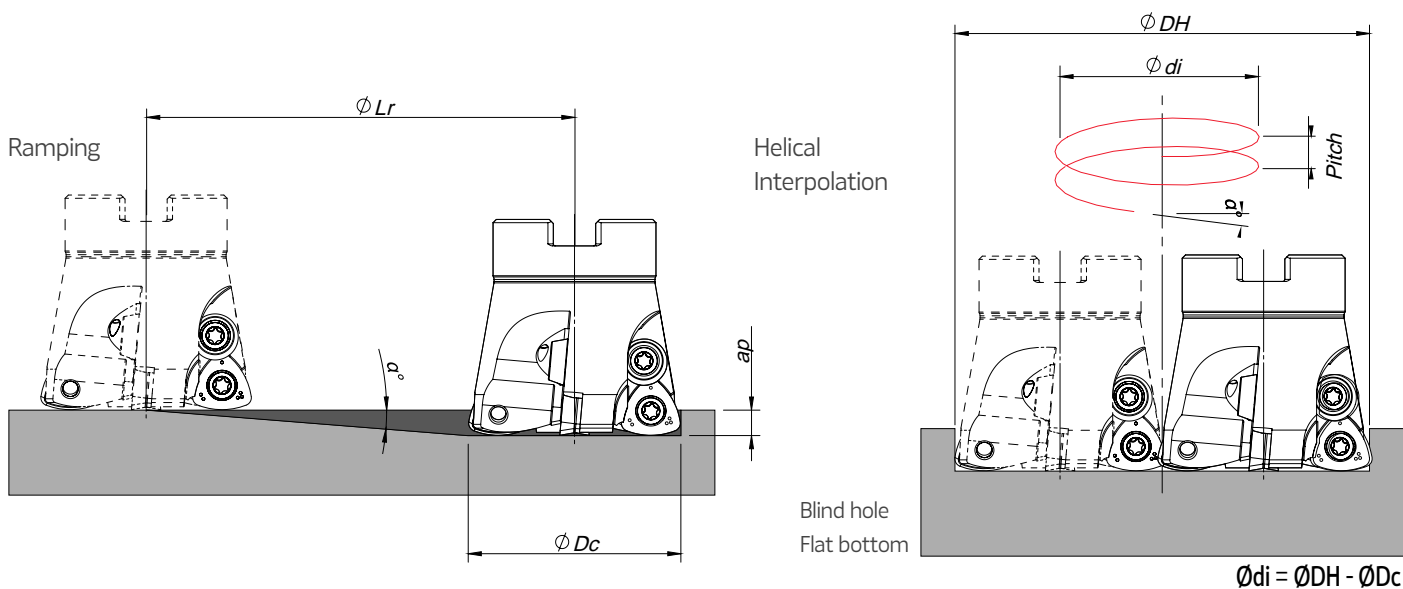

ϕDc	Ramping			Helical Interpolation		
	Max Ramp a°	Max a _p	Min L _r	ϕDH_{min}	ϕDH_{max}	Max Pitch/Rev.
52	0,8	1,5	107,4	89,6	-	1
66	0,4	1,5	214,9	117,6	-	2
				-	102,0	1
80	0,3	1,5	286,5	145,6	-	1
				-	130,0	1
					158,0	1

Note: During helical interpolation do not exceed max Pitch.

HIFEED 50060

A

MILLING

Overview

Face milling

Hifeed milling

Shoulder milling

Profile milling

Hardmill

Center & Chamfer

Spot face

Spare Parts

Technical Data

End Mills

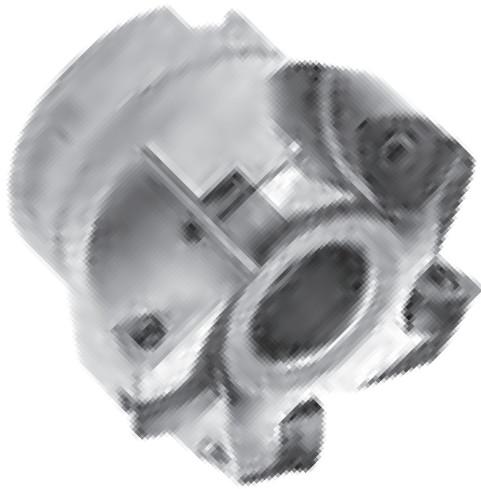

Arbor Mounting

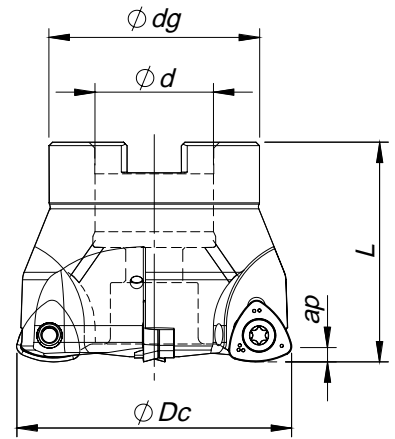
 $\gamma_p=0^\circ$ | $R_p=3,5$

Order code Código	Reference Referência Referencia		Dimensions Dimensões Dimensiones (mm)				Kg	Specifications		Insert Pastilha Inserto	Stock
			ϕDc	ϕd	ϕdg	L		A_p max (mm)	Arbor Type		
181020400	052A50060-03-022045	3	52	22	40	45	0,320	1,8	A	WN... 1207	
181033900	063A50060-04-027050	4	63	27	48	50	0,547	1,8	A	WN... 1207	
181028700	066A50060-04-027050	4	66	27	48	50	0,597	1,8	A	WN... 1207	
181035900	066A50060-05-027050	5	66	27	48	50	0,610	1,8	A	WN... 1207	
181020100	080A50060-05-027050	5	80	27	60	50	1,000	1,8	A	WN... 1207	

Stock item | Produto de stock | Itens de stock

Available under request (see page A-9) | Disponível sobre consulta (consulte a página A-9) | Disponible bajo consulta (mire pagina A-9)

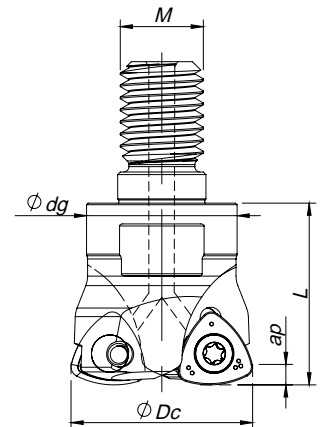

Threaded Coupling

 $\gamma_p=0^\circ$ | $R_p=3,5$

Order code Código	Reference Referência Referencia		Dimensions Dimensões Dimensiones (mm)				Kg	Specifications		Insert Pastilha Inserto	Stock
			ϕDc	ϕM	ϕdg	L		A_p max (mm)			
181039000	035R50060-02-M16035	2	35	M16	29	35	0,166	1,8	WN... 1207		

Stock item | Produto de stock | Itens de stock

Available under request (see page A-9) | Disponível sobre consulta (consulte a página A-9) | Disponible bajo consulta (mire pagina A-9)

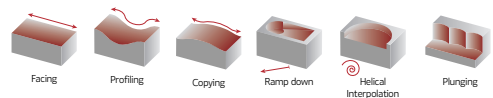

WNMW 1207 | Inserts | Pastilhas | Plaquitas

WNMW

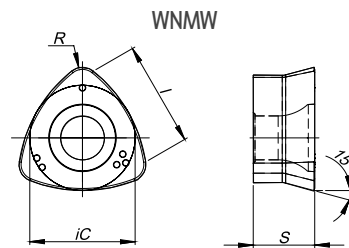

	⁽²⁾ Grade code	P				K		Dimensions Dimensões Dimensiones (mm)			
		PVD				CVD					
⁽¹⁾ Geometry code	ISO Reference	G1	G4	78	86	G1	G4	iC	S	I	R
1121148	WNMW 1207-SP							12,00	7,00	11,90	2,00

First choice | Primeira opção | 1ª opción Stock item | Produto de stock | Itens de stock Available under request (see page A-9) | Disponível sobre consulta (consulte a página A-9) | Disponible bajo consulta (mire página A-9) Insert order code = (1) Geometry Code + (2) Grade Code

SPARE PARTS | Complementos | Repuestos

Cutter ØDc	Insert Screw	Key (Torx)	Order separately	
			Key (Torx - Nm)	Torque Value
R50060 – 35	P0451400	XT20	DT2050	5,0
A50060 – 52 - 80	P0451400	XT20	DT2050	5,0

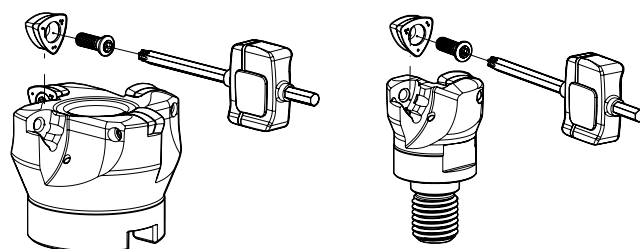

Note: The toolholder is supplied with the XT/PT key. To order the DT key please check the page A-241. Check the procedures for the clamping screws on the page A-241.

GRADES SELECTION GUIDE | Guia para selecção de graus | Tabla para selección de calidades

ISO	PSM	Material	HB (Brinell)	Grades			
				← Wear Resistance		Toughness →	
				PH7910	PH7920	PH6125	PH6135
P	1	Unalloyed Steel	125-220				
	2	Low-Alloyed Steel	220-280				
	3	High-Alloyed Steel	280-380				
K	7	Malleable Cast Iron	130-230				
	8	Grey Cast Iron	180-245				
	9	Nodular Cast iron	160-250				

Good Conditions
 Average Conditions
 Difficult Conditions

HIFEED 50060

RECOMMENDED CUTTING CONDITIONS | Condições de corte recomendadas | Condiciones de corte recomendables

ISO	PSM	Material	HB (Brinell)	Vc (m/min)				Feed fz (mm/t)
				← Wear Resistance			Toughness →	
				PH7910	PH7920	PH6125	PH6135	
P	1	Unalloyed Steel	125-220	180-250	180-240	160-190	150-180	0,30-1,50
	2	Low-Alloyed Steel	220-280	160-230	160-220	140-180	140-170	0,30-1,50
	3	High-Alloyed Steel	280-380	140-220	140-210	130-160	120-150	0,30-1,30
K	7	Malleable Cast Iron	130-230	180-300	160-260	-	-	0,30-1,50
	8	Grey Cast Iron	180-245	160-250	140-240	-	-	0,30-1,50
	9	Nodular Cast iron	160-250	150-200	120-200	-	-	0,30-1,40

(Note 1) Cutting conditions $a_e/D_c=70\%$.

(Note 2) It's possible to occur vibrations in certain cases. Please reduce depth of cut and / or reduce cutting conditions in following cases:

- When using long shank;
- When using long tool overhang with arbor type;
- When application has poor clamping rigidity or when using a low rigidity machine.

(Note 3) PH5... and PHS... can be used wet or dry. PH7... use only air.

PROGRAMMING DATA | Dados para programação | Datos para la programación

Insert	Programming Data			
	Rp	X	b	a _e
WNMW 12	3,5	0,9	8,4	8,0

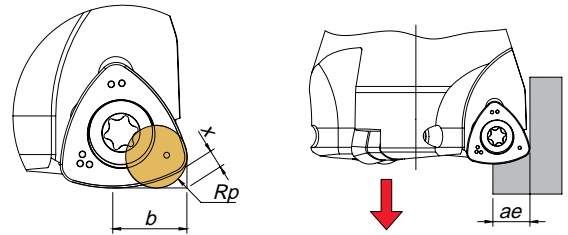

RAMPING AND HELICAL INTERPOLATION

Descida em rampa e interpolação helicoidal | Bajada en rampa e interpolación circular

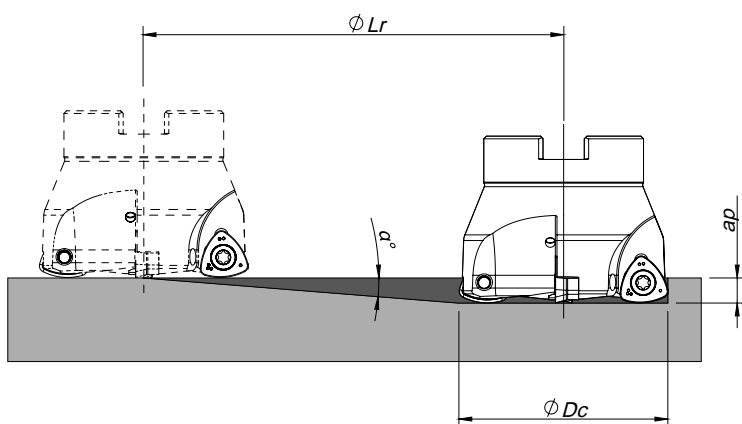

Helical Interpolation

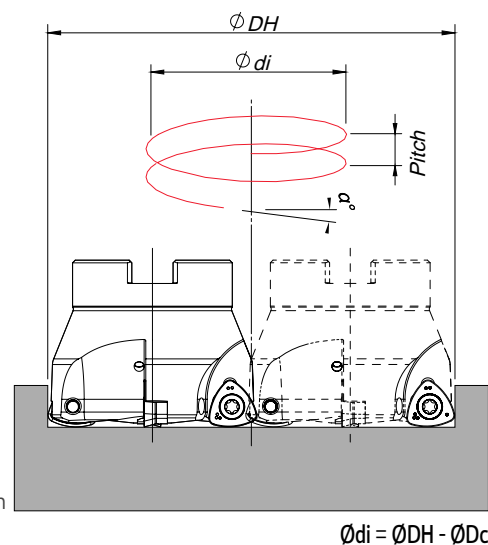

$$\phi di = \phi DH - \phi D_c$$

ϕD_c	Ramping			Helical Interpolation		
	Max Ramp α°	Max a_p	Min L_r	ϕDH_{min}	ϕDH_{max}	Max Pitch/Rev.
35	3,0	1,8	34,3	53,2 -	- 68,0	2 5
52	1,8	1,8	57,3	87,2 -	- 102,0	3 4
63	1,2	1,8	85,9	109,2 -	- 124,0	3 4
66	1,0	1,8	114,6	115,2 -	- 130,0	3 3
80	0,9	1,8	114,6	143,0 -	- 158,0	3 3

Note: During helical interpolation do not exceed max Pitch.

PLUNGING | Mergulho | Plunge

$L \leq 3D_c$	$L > 3D_c$	S_{max}
f_z (mm/t)		
0,10-0,20	0,07-0,14	$S_{max} = \sqrt{D_c \cdot DR - DR^2}$

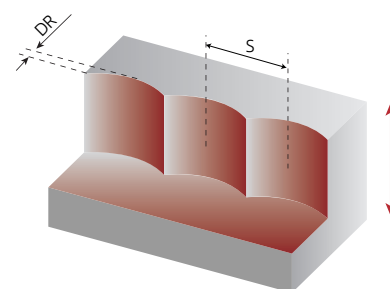

DR (mm)	S max and DR corresponding cutting diameter Dc (mm)				
	Dc (mm)				
	35	52	63	66	80
1,0	5,8	7,1	7,9	8,1	8,9
2,0	8,1	10,0	11,0	11,3	12,5
3,0	9,8	12,1	13,4	13,7	15,2
4,0	11,1	13,9	15,4	15,7	17,4
5,0	12,2	15,3	17,0	17,5	19,4
6,0	13,2	16,6	18,5	19,0	21,1
7,0	14,0	17,7	19,8	20,3	22,6
8,0	14,7	18,8	21,0	21,5	24,0

Note: Recommended for $L \leq 4 D_c$, for $L > 4 D_c$ steps must be reduced to 40%.

HIFEED 06590

A

MILLING

Overview

Face milling

Hifeed milling

Shoulder milling

Profile milling

Hardmill

Center & Chamfer

Spot face

Spare Parts

Technical Data

End Mills

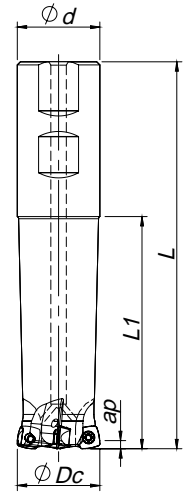

Weldon Shank

$\gamma_p = +5^\circ$ | $R_p = 1,8$

Order code Código	Reference Referência Referencia		Dimensions Dimensões Dimensiones (mm)				Kg	Specifications	Insert Pastilha Inserto	Stock
			ϕDc	ϕd	L	L1		Ap max (mm)		
181047600	020W06590-02-05-020130	2	20	20	130	75	0,250	1,2	SP... 08T3...	
181047900	020W06590-02-05-020190	2	20	20	190	110	0,380	1,2	SP... 08T3...	
181047700	025W06590-03-05-025140	3	25	25	140	80	0,431	1,2	SP... 08T3...	
181048000	025W06590-03-05-025200	3	25	25	200	130	0,611	1,2	SP... 08T3...	
181047800	032W06590-04-05-032150	4	32	32	150	90	0,780	1,2	SP... 08T3...	
181048100	032W06590-04-05-032200	4	32	32	200	130	1,040	1,2	SP... 08T3...	

Stock item | Produto de stock | Itens de stock

Available under request (see page A-9) | Disponível sobre consulta (consulte a página A-9) | Disponible bajo consulta (mire pagina A-9)

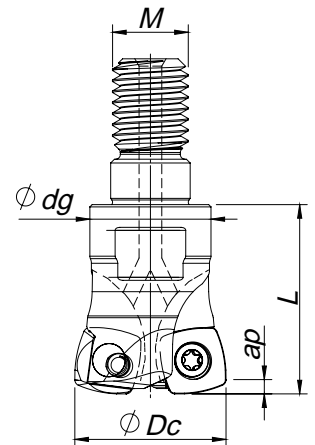

Threaded Coupling

$\gamma = +5^\circ$ | $R_p = 1,8$

Order code Código	Reference Referência Referencia		Dimensions Dimensões Dimensiones (mm)				Kg	Specifications	Insert Pastilha Inserto	Stock
			ϕDc	ϕM	ϕdg	L		Ap max (mm)		
181031100	020R06590-02-05-M10025	2	20	M10	16	25	0,040	1,2	SP... 08T3...	
181029400	025R06590-03-05-M12028	3	25	M12	21	28	0,071	1,2	SP... 08T3...	
181029600	032R06590-04-05-M16035	4	32	M16	29	35	0,162	1,2	SP... 08T3...	
181045800	035R06590-04-05-M16035	4	35	M16	29	35	0,176	1,2	SP... 08T3...	
181031000	042R06590-05-05-M16035	5	42	M16	29	35	0,215	1,2	SP... 08T3...	

Stock item | Produto de stock | Itens de stock

Available under request (see page A-9) | Disponível sobre consulta (consulte a página A-9) | Disponible bajo consulta (mire pagina A-9)

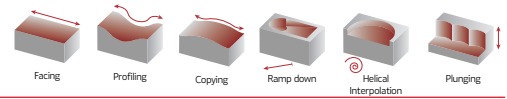

SP..08T3.. || Inserts | Pastilhas | Plaquetas

SPKW

SPKT

SPKW | SPKT

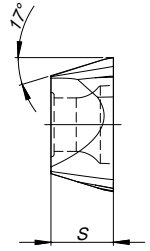
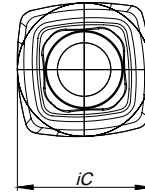

		P	M	K	Dimensions Dimensões Dimensiones (mm)	
		PVD	PVD	PVD	iC	S
(2) Grade code		68	68	68		
(1) Geometry code	ISO Reference	PH6920	PH6920	PH6920		
1111364	SPKW 08T308-E	⊗		⊗	8,50	3,97
1121227	SPKW 08T308-S	⊗		⊗	8,50	3,97
1111314	SPKT 08T308-E	⊗	⊗	⊗	8,50	3,97

⊗ First choice | Primeira opção | 1ª opción ⊗ Stock item | Produto de stock | Itens de stock ○ Available under request (see page A-9) | Disponível sobre consulta (consulte a página A-9) | Disponible bajo consulta (mire página A-9) Insert order code = (1) Geometry Code + (2) Grade Code

SPARE PARTS || Complementos | Repuestos

Cutter ØDc	Insert Screw	Key (Torx)	Order separately	
			Key (Torx - Nm)	Torque Value
W06590 - 20 - 32	P0300800	XT09	DT0914	1,4
R06590 - 20 - 42	P0300800	XT09	DT0914	1,4

Note: The toolholder is supplied with the XT/PT key. To order the DT key please check the page A-241. Check the procedures for the clamping screws on the page A-241.

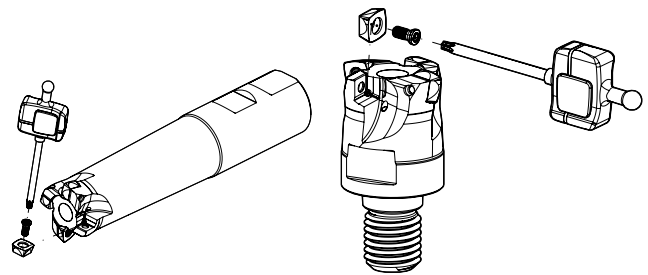

HIFEED 06590

RECOMMENDED CUTTING CONDITIONS | Condições de corte recomendadas | Condiciones de corte recomendables

ISO	PSM	Material	HB (Brinell)	Vc (m/min)		Feed fz (mm/t)	
				PH6920	SP ... 08T308		
P	1	Unalloyed Steel	125-220	150-230		0,30-1,50	
	2	Low-Alloyed Steel	220-280	140-220		0,30-1,50	
	3	High-Alloyed Steel	280-380	130-180		0,30-1,30	
M	4	SS - Ferritic / Martensitic	200-330	120-160		0,30-1,40	
	5	SS - Austenitic	200-330	100-150		0,30-1,40	
	6	SS - Austenitic-ferritic (Duplex)	230-260	70-110		0,30-1,20	
K	7	Malleable Cast Iron	130-230	150-280		0,30-1,50	
	8	Grey Cast Iron	180-245	130-230		0,30-1,50	
	9	Nodular Cast iron	160-250	80-190		0,30-1,40	

(Note 1) Cutting conditions $a_e/D_c=70\%$.

(Note 2) It's possible to occur vibrations in certain cases. Please reduce depth of cut and / or reduce cutting conditions in following cases:

- When using long shank;
- When using long tool overhang with arbor type;
- When application has poor clamping rigidity or when using a low rigidity machine.

(Note 3) Use only air.

(Note 4) It's possible to occur vibrations in certain cases. Please reduce depth of cut and / or reduce cutting conditions in following cases:

- When using long shank;
- When using long tool overhang with arbor type;
- When application has poor clamping rigidity or when using a low rigidity machine.

CHIP-BREAKER SELECTION GUIDE | Guia para aplicações do quebra-apanas | Guía para aplicación del rompevirutas

ISO	PSM	Material	HB (Brinell)	Chip-Breaker Application	
				1st choice	Difficult Operations
P	1	Unalloyed Steel	125-220	SPKT 08...	SPKW 08...
	2	Low-Alloyed Steel	220-280	SPKW 08...	-
	3	High-Alloyed Steel	280-380	SPKW 08...	-
M	4	SS - Ferritic / Martensitic	200-330	SPKT 08...	-
	5	SS - Austenitic	200-330	SPKT 08...	-
	6	SS - Austenitic-ferritic (Duplex)	230-260	SPKW 08...	SPKW 08...
K	7	Malleable Cast Iron	130-230	SPKT 08...	SPKW 08...
	8	Grey Cast Iron	180-245	SPKW 08...	-
	9	Nodular Cast iron	160-250	SPKW 08...	-

PROGRAMMING DATA | Dados para programação | Datos para la programación

Insert	Programming Data			
	Rp	X	b	a_e
SP... 08T3...	1,9	0,7	5,6	6,6

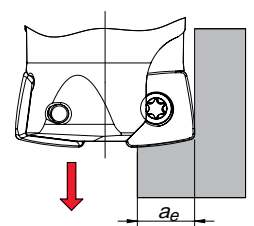
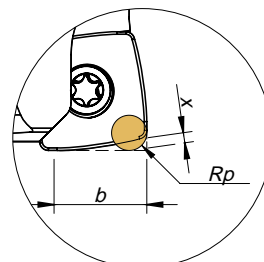

RAMPING AND HELICAL INTERPOLATION

Descida em rampa e interpolação helicoidal | Bajada en rampa e interpolación circular

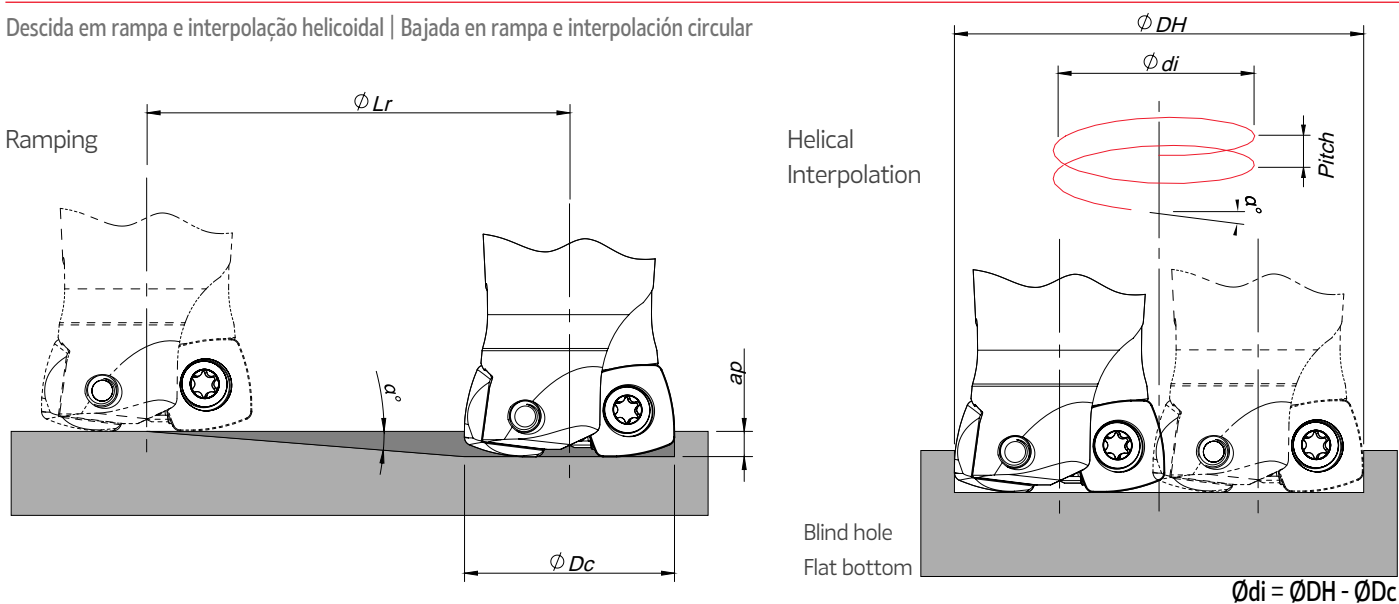

ϕDc	Ramping			Helical Interpolation		
	Max Ramp α°	Max ap	Min Lr	ϕDH_{min}	ϕDH_{max}	Max Pitch/Rev.
20	0,5	1,2	137,5	27,8	-	0,2
25	1	1,2	68,7	37,8	38,0	0,5
32	1,4	1,2	49,1	51,8	48,0	0,7
35	1,1	1,2	62,5	57,8	62,0	1,2
42	0,9	1,2	76,4	71,8	68,0	1,5
					82,0	2,3
						1,3
						2,0
						1,4
						1,9

Note: During helical interpolation do not exceed max Pitch.

PLUNGING | Mergulho | Plunge

$L \leq 3Dc$	$L > 3Dc$	S_{max}
f_z (mm/t)		$S_{max} = \sqrt{DC \cdot Dr - Dr^2}$
0,08-0,15	0,05-0,10	

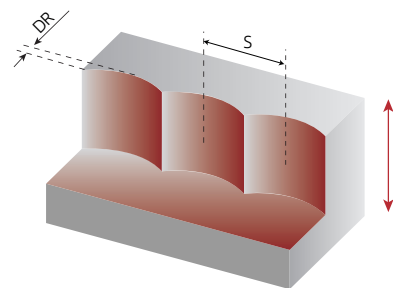

S max and DR corresponding cutting diameter Dc (mm)					
DR (mm)	Dc (mm)				
	20	25	32	35	42
1,0	4,4	4,9	5,6	5,8	6,4
2,0	6,0	6,8	7,7	8,1	8,9
3,0	7,1	8,1	9,3	9,8	10,8
4,0	8,0	9,2	10,6	11,1	12,3
5,0	8,7	10,0	11,6	12,2	13,6
6,0	9,2	10,7	12,5	13,2	14,7

Note: Recommended for $L \leq 4 Dc$ for extra long tool this step and side cut must be reduced.

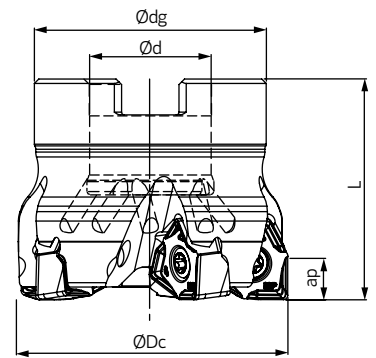

Arbor Mounting

$$K_r = 90^\circ \quad | \quad \gamma_p = -6^\circ$$

Order code Código	Reference Referência Referencia		Dimensions Dimensões Dimensiones (mm)				Kg	Specifications		Insert Pastilha Inserto	Stock
			ØDc	Ød	Ødg	L		Arbor Type	Ap max (mm)		
181174900	040A49590-03-06-016040		40	16	32	40	0,15	A	7,5	WNXT 0806...	
181175000	040A49590-04-06-016040		40	16	32	40	0,13	A	7,5	WNXT 0806...	
181173400	050A49590-04-06-022040		50	22	42	40	0,39	A	7,5	WNXT 0806...	
181165600	050A49590-05-06-022040		50	22	42	40	0,38	A	7,5	WNXT 0806...	
181173500	063A49590-05-06-022040		63	22	52	40	0,5	A	7,5	WNXT 0806...	
181173600	063A49590-06-06-022040		63	22	52	40	0,49	A	7,5	WNXT 0806...	
181173700	080A49590-07-06-027050		80	27	60	50	1,18	B	7,5	WNXT 0806...	
181173800	080A49590-09-06-027050		80	27	60	50	1,16	B	7,5	WNXT 0806...	
181173900	100A49590-08-06-032050		100	32	80	50	1,62	B	7,5	WNXT 0806...	
181174000	100A49590-11-06-032050		100	32	80	50	1,55	B	7,5	WNXT 0806...	
181174100	125A49590-11-06-040063		125	40	90	63	2,82	B	7,5	WNXT 0806...	
181174200	125A49590-14-06-040063		125	40	90	63	2,76	B	7,5	WNXT 0806...	

Stock item | Produto de stock | Itens de stock

Available under request | Disponível sobre consulta
Disponível bajo consulta

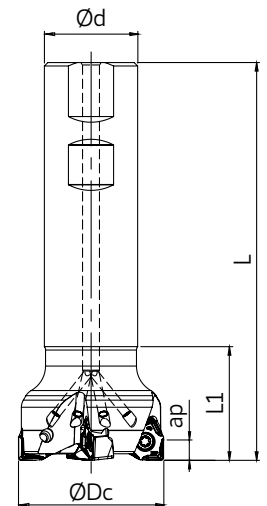

Weldon Shank

$$K_r = 90^\circ \quad | \quad \gamma_p = -6^\circ$$

Order code Código	Reference Referência Referencia		Dimensions Dimensões Dimensiones (mm)				Kg	Specifications	Insert Pastilha Inserto	Stock
			ØDc	Ød	L	L1		ap max (mm)		
181174300	032W49590-02-06-032125		32	32	125	40	0,65	7,5	WNXT 0806...	
181174400	032W49590-03-06-032125		32	32	125	40	0,60	7,5	WNXT 0806...	
181174500	040W49590-03-06-032130		40	32	130	40	0,70	7,5	WNXT 0806...	
181174600	040W49590-04-06-032130		40	32	130	40	0,65	7,5	WNXT 0806...	
181174700	050W49590-04-06-032140		50	32	140	45	0,86	7,5	WNXT 0806...	
181174800	050W49590-05-06-032140		50	32	140	45	0,81	7,5	WNXT 0806...	

Stock item | Produto de stock | Itens de stock

Available under request | Disponível sobre consulta
Disponível bajo consulta

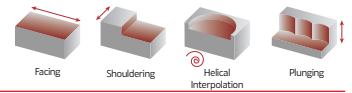

WNXT | Inserts | Pastilhas | Plaquetas

WNXT NEW

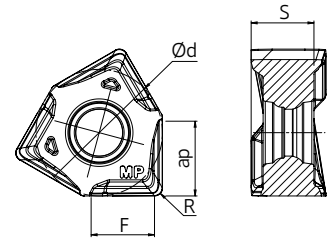

(1) Geometry code	(2) Grade code Reference Referência Referencia	P		K		Dimensions Dimensões Dimensiones (mm)			
		PVD		PVD					
		T1	P4	T1	P4	iC	S	R	F
1113000	WNXT 080608 PNSR-MP	PHP920	PHP930	PHP920	PHP930	12,7	6,3	0,8	4,1

First choice | Primeira opção | 1ª opción
 Stock item | Produto de stock | Itens de stock
 Available under request | Disponível sobre consulta | Disponible bajo consulta
 Insert order code = (1) Geometry Code + (2) Grade Code

SPARE PARTS Complementos | Repuestos

Cutter ØDc	Insert Screw	Key (Torx)	Key (Torx - Nm)	Torque Value	Screw	DIN 6368 Wrench	Retaining Screw
W49590 - 32 - 50	P0401200	XT15	DT1530	3,0	-	-	-
A49590 - 40	P0401200	XT15	DT1530	3,0	-	-	290087600
A49590 - 50 - 63	P0401200	XT15	DT1530	3,0	-	-	-
A49590 - 80	P0401200	XT15	DT1530	3,0	J0123510	SD6368-12	-
A49590 - 100	P0401200	PT15	DT1530	3,0	J0164110	SD6368-16	-
A49590 - 125	P0401200	PT15	DT1530	3,0	J0204610	SD6368-20	-

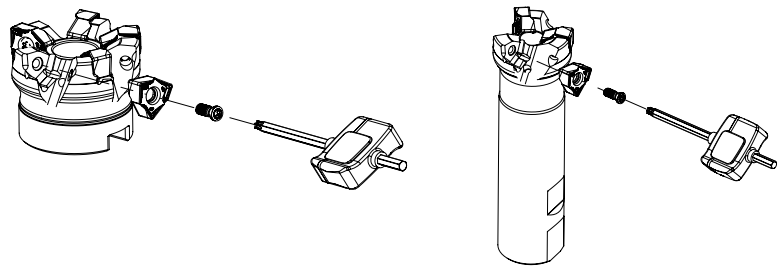

A
MILLING
Overview
Face milling
Hifeed milling
Shoulder milling
Profile milling
Hardmill
Center & Chamfer
Spot face
Spare Parts
Technical Data
End Mills



GRADES SELECTION GUIDE | Guia para seleção de graus | Tabla para selección de calidades

ISO	PSM	Material	HB (Brinell)	Grades		
				← Wear Resistance		Toughness →
				PHP920	PHP930	
P	1	Unalloyed Steel	125-220	✓	✓	
	2	Low-Alloyed Steel	220-280	✓	✓	
	3	High-Alloyed Steel	280-380	✓	✓	
K	7	Malleable Cast Iron	130-230	✓	✓	
	8	Grey Cast Iron	180-245	✓	✓	
	9	Nodular Cast iron	160-250	✓	✓	

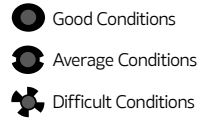

RECOMMENDED CUTTING CONDITIONS | Condições de corte recomendadas | Condiciones de corte recomendables

ISO	PSM	Material	HB (Brinell)	Vc (m/min)		Feed fz (mm/t)	
				← Wear Resistance			Toughness →
				PHP920	PHP930		WNXT
P	1	Unalloyed Steel	125-220	180-250	160-230	0,08 - 0,25	
	2	Low-Alloyed Steel	220-280	160-230	140-210	0,08 - 0,25	
	3	High-Alloyed Steel	280-380	140-220	120-200	0,08 - 0,20	
K	7	Malleable Cast Iron	130-230	130-230	150-250	0,08 - 0,25	
	8	Grey Cast Iron	180-245	180-245	140-230	0,08 - 0,25	
	9	Nodular Cast iron	160-250	120-210	100-200	0,08 - 0,20	

PLUNGING | Mergulho | Plunge

L ≤ 3Dc	L > 3Dc	S max.
fz (mm/t)		
0,10-0,15	0,08-0,12	$S_{max} = \sqrt{DC \cdot Dr - Dr^2}$

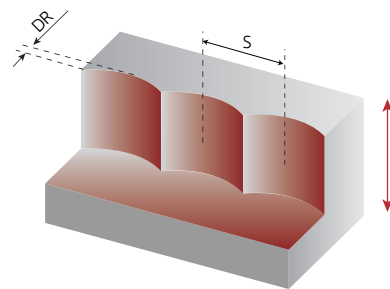

S max and DR corresponding cutting diameter Dc (mm)							
DR (mm)	Dc (mm)						
	32	40	50	63	80	100	125
1,0	5,6	6,2	7,0	7,9	8,9	9,9	11,1
2,0	7,7	8,7	9,8	11,0	12,5	14,0	15,7
3,0	9,3	10,5	11,9	13,4	15,2	17,1	19,1
4,0	10,6	12,0	13,6	15,4	17,4	19,6	22,0



RAMPING AND HELICAL INTERPOLATION

Descida em rampa e interpolação helicoidal | Bajada en rampa e interpolación circular

Ramping

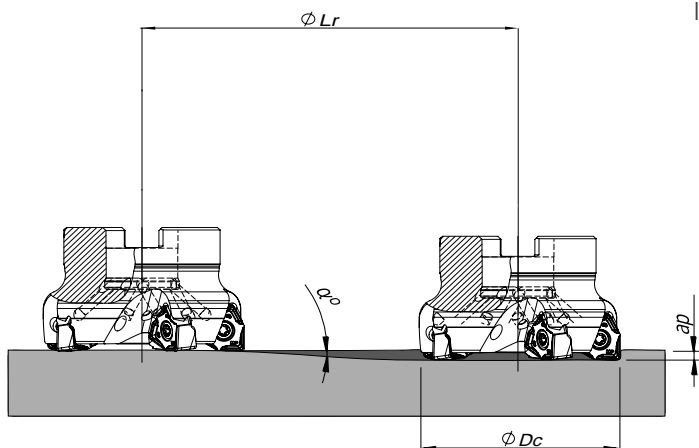

Helical Interpolation

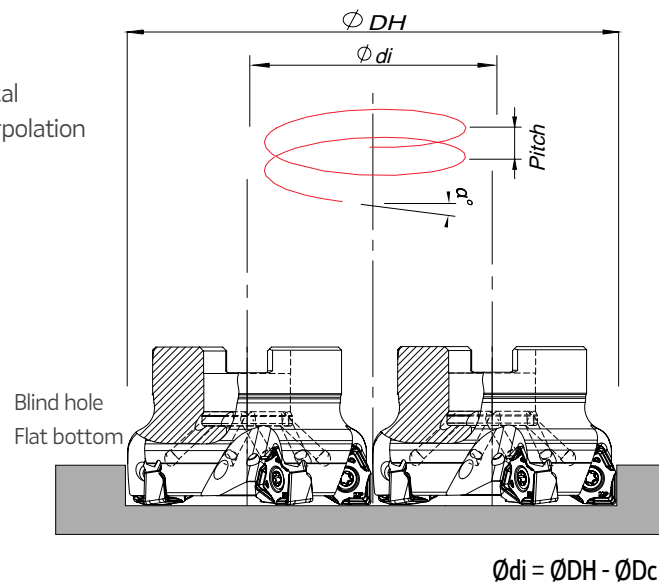

ϕ_{Dc}	Ramping			Helical Interpolation		
	Max Ramp a°	Max a_p	Min L_r	ϕ_{DHmin}	ϕ_{DHmax}	Max Pitch/Rev.
32	4,0	7,5	107,3	52 -	- 62	4,3 6,6
40	3,8	7,5	112,9	68 -	- 78	5,8 8
50	3,5	7,5	122,6	88 -	- 98	7,3 9,2
63	3,5	7,5	122,6	114 -	- 124	9 11,7
80	3,0	7,5	143,1	148 -	- 158	11,1 12,9
100	2,1	7,5	204,5	188 -	- 198	10,1 11,3
125	1,4	7,5	306,9	238 -	- 248	8,6 9,4

Note: During helical interpolation do not exceed max Pitch.

(*) Down cutting is recommended, tool pass rotation should be counter-clockwise.

(*) In case of ramping and helical interpolation, apply 70% or less feed (f_z) from recommended cutting conditions table.



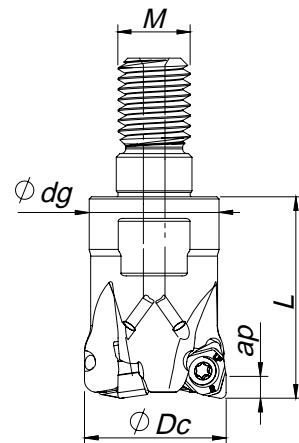

Threaded Coupling

$\kappa_r = 90^\circ$ | $\gamma_p = -7^\circ$

Order code Código	Reference Referência Referencia		Dimensions Dimensões Dimensiones (mm)				Kg	Specification	Insert Pastilha Inserto	Stock
			ϕDc	M	ϕdg	L		A_p max (mm)		
181136000	016R49090-02-07-M08023	2	16	M08	13	23	0,023	3,00	WNHU 04T308-LP	
181128300	020R49090-03-07-M10028	3	20	M10	18	28	0,052	3,00	WNHU 04T308-LP	
181110900	025R49090-04-07-M12030	4	25	M12	21	30	0,078	3,00	WNHU 04T308-LP	
181128400	032R49090-05-07-M16035	5	32	M16	29	35	0,150	3,00	WNHU 04T308-LP	

Stock item | Produto de stock | Itens de stock

Available under request (see page A-9) | Disponível sobre consulta (consulte a página A-9) | Disponible bajo consulta (mire pagina A-9)

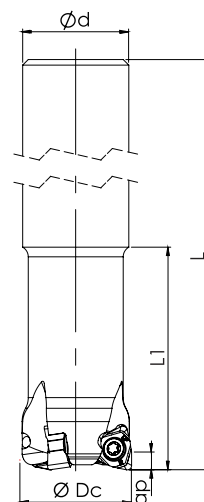

Cylindrical Shank

$\kappa_r = 90^\circ$ | $\gamma_p = -7^\circ$

Order code Código	Reference Referência Referencia		Dimensions Dimensões Dimensiones (mm)				Kg	Specification	Insert Pastilha Inserto	Stock
			ϕDc	ϕd	L	L1		A_p max (mm)		
181136100	016E49090-02-07-U015150	2	16	15	150	32	0,185	3,00	WNHU 04T308-LP	
181136200	020E49090-03-07-U019150	3	20	19	150	40	0,292	3,00	WNHU 04T308-LP	
181136300	025E49090-04-07-U024150	4	25	24	150	50	0,471	3,00	WNHU 04T308-LP	

Stock item | Produto de stock | Itens de stock

Available under request (see page A-9) | Disponível sobre consulta (consulte a página A-9) | Disponible bajo consulta (mire pagina A-9)

SPARE PARTS | Complementos | Repuestos

Cutter ϕDc	Order separately			
	Insert Screw	Key (Torx)	Key (Torx - Nm)	Torque Value
R49090 - 20-32	PO250704	XT08	DT0812	1,2
E49090 - 16-25	PO250704	XT08	DT0812	1,2

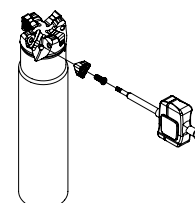
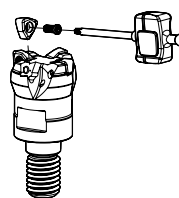

Note: The toolholder is supplied with the XT/PT key. To order the DT key please check the page A-241.
Check the procedures for the clamping screws on the page A-241.

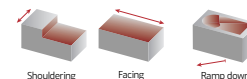

WNHU 04T308 | Inserts | Pastilhas | Plaquetas

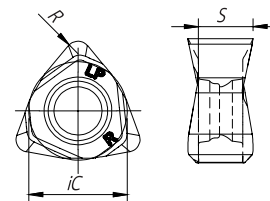

(1) Geometry code	(2) Grade code	P			K			Dimensions Dimensões Dimensiones (mm)		
		PVD			PVD			iC	S	R
		X5	T1	P4	X5	T1	P4			
1112277	WNHU 04T308 PNER-LP	PHP910	PHP920	PHP930	PHP910	PHP920	PHP930	6,35	3,50	0,80

🟢 First choice | Primeira opção | 1ª opción
🟡 Stock item | Produto de stock | Itens de stock
⚪ Available under request (see page A-9) | Disponível sobre consulta (consulte a página A-9) | Disponible bajo consulta (mire página A-9)
Insert order code = (1) Geometry Code + (2) Grade Code

GRADES SELECTION GUIDE | Guia para selecção de graus | Tabla para selección de calidades

ISO	PSM	Material	HB (Brinell)	Grades		
				← Wear Resistance		Toughness →
				PHP910	PHP920	PHP930
P	1	Unalloyed Steel	125-220	●	●	●
	2	Low-Alloyed Steel	220-280	●	●	●
	3	High-Alloyed Steel	280-380	●	●	●
K	7	Malleable Cast Iron	130-230	●	●	●
	8	Grey Cast Iron	180-245	●	●	●
	9	Nodular Cast iron	160-250	●	●	●

● Good Conditions
● Average Conditions
● Difficult Conditions

RECOMMENDED CUTTING CONDITIONS | Condições de corte recomendadas | Condiciones de corte recomendables

ISO	PSM	Material	HB (Brinell)	Vc (m/min)			Feed fz (mm/t)
				← Wear Resistance		Toughness →	
				PHP910	PHP920	PHP930	WNHU 04T3
P	1	Unalloyed Steel	125-220	180-250	180-250	160-230	0,10-0,30
	2	Low-Alloyed Steel	220-280	160-240	160-230	140-210	0,10-0,30
	3	High-Alloyed Steel	280-380	140-230	140-220	120-200	0,10-0,25
K	7	Malleable Cast Iron	130-230	180-300	160-270	150-250	0,10-0,30
	8	Grey Cast Iron	180-245	160-250	140-250	140-230	0,10-0,30
	9	Nodular Cast iron	160-250	150-210	120-210	100-200	0,10-0,25

Insert	Feed fz (mm/t)		ap Rec.
	Roughing	Finishing	
WNHU 04T308-LP	0.15-0.30	0.10-0.25	0.50-3.00

(Note 1) Cutting conditions should be adjusted according to the machine and work rigidity.
 (Note 2) If chattering occurs, reduce ap and Vc by 30% and keep the same fz per tooth.



A

MILLING

Overview

Face milling

Hi-feed milling

Shoulder milling

Profile milling

Hardmill

Center & Chamfer

Spotface

Spare Parts

Technical Data

End Mills

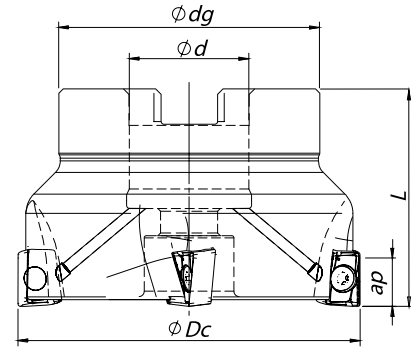

Arbor Mounting

$K_r = 90^\circ$ | $\gamma_p = -7^\circ$

Order code Código	Reference Referência Referencia		Dimensions Dimensões Dimensiones (mm)				Kg	Specifications		Insert Pastilha Inserto	Stock
			ϕDc	ϕd	ϕdg	L		Arbor Type	Ap max (mm)		
181075300	040A17190-04-07-016040	4	40	16	32	40	0,21	A	9,00	ANHX 1004...	
181075400	040A17190-05-07-016040	5	40	16	32	40	0,21	A	9,00	ANHX 1004...	
181075500	050A17190-05-07-022040	5	50	22	42	40	0,35	A	9,00	ANHX 1004...	
181075600	050A17190-07-07-022040	7	50	22	42	40	0,34	A	9,00	ANHX 1004...	
181075700	063A17190-07-07-022040	7	63	22	52	40	0,55	A	9,00	ANHX 1004...	
181075800	063A17190-09-07-022040	9	63	22	52	40	0,54	A	9,00	ANHX 1004...	
181075900	080A17190-08-07-027050	8	80	27	60	50	1,00	B	9,00	ANHX 1004...	
181076000	080A17190-10-07-027050	10	80	27	60	50	1,00	B	9,00	ANHX 1004...	
181076100	100A17190-09-07-032050	9	100	32	80	50	1,80	B	9,00	ANHX 1004...	
181076200	100A17190-12-07-032050	12	100	32	80	50	1,80	B	9,00	ANHX 1004...	

Stock item | Produto de stock | Itens de stock

Available under request (see page A-9) | Disponível sobre consulta (consulte a página A-9) | Disponible bajo consulta (mire pagina A-9)

ANHX 1004.. | Inserts | Pastilhas | Plaquitas



(1) Geometry code	(2) Grade code	P				M		K				N	S		Dimensions Dimensões Dimensiones (mm)						
		PVD						PVD		PVD				UNC	PVD		iC	S	I	R	F
		X5	T1	P4	G6	X9	G6	X5	T1	P4	G6	10	X9	G6							
1111652	ANHX 100405 PNR-LP																6,60	6,20	10,00	0,50	0,85
1112106	ANHX 100408 PNR-LP																6,60	6,20	10,00	0,80	0,60
1111908	ANHX 100412 PNR-LP																6,60	6,20	10,00	1,20	0,30
1112005	ANHX 100405 PNER-LM																6,60	6,20	10,00	0,50	0,85
1112162	ANHX 100408 PNER-LM																6,60	6,20	10,00	0,80	0,60
1112103	ANHX 100412 PNER-LM																6,60	6,20	10,00	1,20	0,30
1111997	ANHX 100405 PNFR-LN																6,60	6,20	10,00	0,50	0,85
1112102	ANHX 100412 PNR-LN																6,60	6,20	10,00	1,20	0,30

First choice | Primeira opção | 1ª opción Stock item | Produto de stock | Itens de stock

Available under request (see page A-9) | Disponível sobre consulta (consulte a página A-9) | Disponible bajo consulta (mire pagina A-9)

Insert order code = (1) Geometry Code + (2) Grade Code

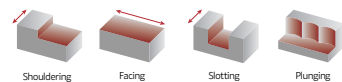

Weldon Shank
 $K_r = 90^\circ$ | $\gamma_p = -7^\circ (-6^\circ \times)$

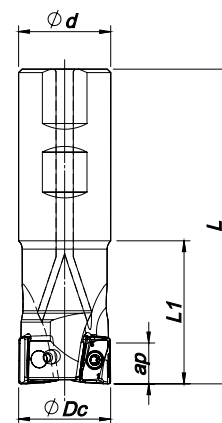

Order code Código	Reference Referência Referencia		Dimensions Dimensões Dimensiones (mm)				Kg	Specifications	Insert Pastilha Inserto	Stock
			ØDc	Ød	L	L1		Ap max (mm)		
181075000	014W17190-01-06-016090*	1	14	16	90	23	0,188	9,00	ANHX 1004...	
181101400	016W17190-02-06-016090*	2	16	16	90	25	0,123	9,00	ANHX 1004...	
181096800	016W17190-02-06-016150*	2	16	16	150	25	0,190	9,00	ANHX 1004...	
181075200	018W17190-02-06-016090*	2	18	16	90	23	0,125	9,00	ANHX 1004...	
181071400	020W17190-02-06-020100*	2	20	20	100	30	0,210	9,00	ANHX 1004...	
181071500	020W17190-03-06-020100*	3	20	20	100	30	0,206	9,00	ANHX 1004...	
181074400	025W17190-02-06-025115*	2	25	25	115	35	0,391	9,00	ANHX 1004...	
181074500	025W17190-03-06-025115*	3	25	25	115	35	0,387	9,00	ANHX 1004...	
181074600	032W17190-03-06-032125*	3	32	32	125	40	0,701	9,00	ANHX 1004...	
181074700	032W17190-04-06-032125*	4	32	32	125	40	0,698	9,00	ANHX 1004...	
181074800	040W17190-04-07-032130	4	40	32	130	40	0,780	9,00	ANHX 1004...	
181074900	040W17190-05-07-032130	5	40	32	130	40	0,777	9,00	ANHX 1004...	

Stock item | Produto de stock | Itens de stock

Available under request (see page A-9) | Disponível sobre consulta (consulte a página A-9) | Disponible bajo consulta (mire pagina A-9)

SPARE PARTS | Complementos | Repuestos

Cutter ØDc	Insert Screw	Key (Torx)	Order separately		Order separately	
			Key (Torx - Nm)	Torque Value	Screw	DIN 6368 Wrench
W17190 - 14 - 40	P0300800	XT09	DT0914	1,4	-	-
A17190 - 40 - 63	P0300800	XT09	DT0914	1,4	-	-
A17190 - 80	P0300800	XT09	DT0914	1,4	J0123510	SD6368-12
A17190 - 100	P0300800	XT09	DT0914	1,4	J0164110	SD6368-16

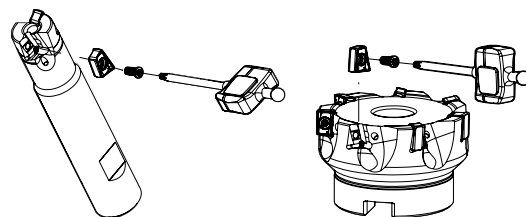

Note: The toolholder is supplied with the XT/PT key. To order the DT key please check the page A-241.
 Check the procedures for the clamping screws on the page A-241.

GRADES SELECTION GUIDE | Guia para selecção de graus | Tabla para selección de calidades

ISO	PSM	Material	HB (Brinell)	Grades					
				← Wear Resistance			Toughness →		
				PH0910	PHP910	PHP920	PHP930	PHH930	PH7740
P	1	Unalloyed Steel	125-220	●	●	●	●	●	●
	2	Low-Alloyed Steel	220-280		●	●	●		●
	3	High-Alloyed Steel	280-380		●	●	●		●
M	4	SS - Ferritic / Martensitic	200-330					●	●
	5	SS - Austenitic	200-330					●	●
	6	SS - Austenitic-ferritic (Duplex)	230-260					●	●
K	7	Malleable Cast Iron	130-230		●	●	●		●
	8	Grey Cast Iron	180-245		●	●	●		●
	9	Nodular Cast iron	160-250		●	●	●		●
N	10	Aluminium and Non Ferrous	30-130	●					
S	11	Heat Resistant Super Alloys	200-320					●	●

- Good Conditions
- Average Conditions
- Difficult Conditions

RECOMMENDED CUTTING CONDITIONS | Condições de corte recomendadas | Condiciones de corte recomendables

ISO	PSM	Material	HB (Brinell)	Vc (m/min)						Feed fz (mm/t)		
				← Wear Resistance			Toughness →			ANH... LP	ANH... LM	ANH... LN
				PH0910	PHP910	PHP920	PHP930	PHH930	PH7740			
P	1	Unalloyed Steel	125-220	-	180-250	180-250	160-230	-	140-200	0,08-0,20	0,08-0,20	-
	2	Low-Alloyed Steel	220-280	-	160-240	160-230	140-210	-	130-180	0,08-0,20	0,08-0,15	-
	3	High-Alloyed Steel	280-380	-	140-230	140-220	120-200	-	100-170	0,08-0,15	0,08-0,15	-
M	4	SS - Ferritic / Martensitic	200-330	-	-	-	-	140-210	130-180	-	0,08-0,20	-
	5	SS - Austenitic	200-330	-	-	-	-	120-170	110-160	-	0,08-0,15	-
	6	SS - Austenitic-ferritic (Duplex)	230-260	-	-	-	-	100-150	90-150	-	0,08-0,15	-
K	7	Malleable Cast Iron	130-230	-	180-300	160-270	150-250	-	140-220	0,08-0,25	0,08-0,20	-
	8	Grey Cast Iron	180-245	-	160-250	140-250	140-230	-	120-210	0,08-0,20	0,08-0,20	-
	9	Nodular Cast iron	160-250	-	150-210	120-210	100-200	-	100-190	0,08-0,20	0,08-0,15	-
N	10	Aluminium and Non Ferrous	30-130	100-2000	-	-	-	-	-	-	-	0,08-0,20
S	11	Heat Resistant Super Alloys	200-320	-	-	-	-	30-110	30-100	-	0,08-0,15	-

(Note 1) Cutting conditions $a_e/D_c=70\%$.

(Note 2)

Operation	a_e	Vc & fz	a_p (mm)
Slotting	100%	<20%	2,0-3,5
Shouldering	<50%	>8%	3,0-6,0
	≤25%	>12%	6,0-8,5

(Note 3)

It's possible to occur vibrations in certain cases. Please reduce depth of cut and / or reduce cutting conditions in following cases:

- When using long shank;
- When using long tool overhang with arbor type;
- When application has poor clamping rigidity or when using a low rigidity machine.

CHIP-BREAKER SELECTION GUIDE | Guia de selecção do quebra- aparas | Guía de selección del rompevirutas

ISO	PSM	Material	HB (Brinell)	Chip Breaker Application	
				1 st choice	Difficult Operations
P	1	Unalloyed Steel	125-220	ANHX 10... LM	ANHX 10... LP
	2	Low-Alloyed Steel	220-280	ANHX 10... LM	ANHX 10... LP
	3	High-Alloyed Steel	280-380	ANHX 10... LM	ANHX 10... LP
M	4	SS - Ferritic / Martensitic	200-330	ANHX 10... LM	-
	5	SS - Austenitic	200-330	ANHX 10... LM	-
	6	SS - Austenitic-ferritic (Duplex)	220-260	ANHX 10... LM	-
K	7	Malleable Cast Iron	130-230	ANHX 10... LM	ANHX 10... LP
	8	Grey Cast Iron	180-245	ANHX 10... LM	ANHX 10... LP
	9	Nodular Cast iron	160-250	ANHX 10... LP	-
N	10	Aluminium and Non Ferrous	30-130	ANHX 10... LN	-
S	11	Heat Resistant Super Alloys	200-320	ANHX 10... LM	-

PLUNGING | Mergulho | Plunge

L < 3Dc	L > 3Dc	S max.
f _z (mm/t)		
0,10-0,20	0,10-0,14	$S_{max} = \sqrt{Dc \cdot Dr - Dr^2}$

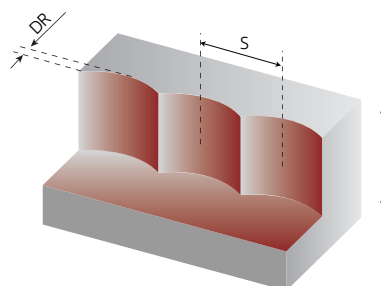

S max and DR corresponding cutting diameter Dc (mm)											
DR (mm)	Dc (mm)										
	14	16	18	20	25	32	40	50	63	80	100
1,0	3,6	3,9	4,1	4,4	4,9	5,6	6,2	7,0	7,9	8,9	9,9
2,0	4,9	5,3	5,7	6,0	6,8	7,7	8,7	9,8	11,0	12,5	14,0
3,0	5,7	6,2	6,7	7,1	8,1	9,3	10,5	11,9	13,4	15,2	17,1



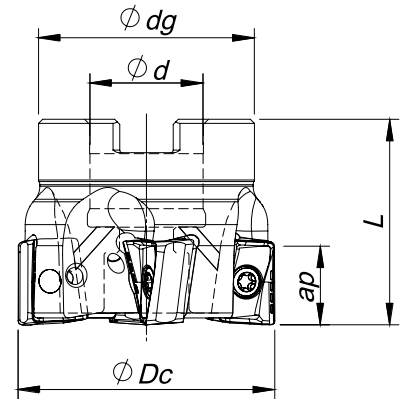

Arbor Mounting

$K_r = 90^\circ$ | $\gamma_p = -6^\circ$

Order code Código	Reference Referência Referencia		Dimensions Dimensões Dimensiones (mm)				Kg	Specifications		Insert Pastilha Inserto	Stock
			ϕDc	ϕd	ϕDg	L		Arbor Type	Ap max		
181116400	040A17590-04-06-016040	4	40	16	32	40	0,17	A	11,00	ANHX 1206...	
181114500	050A17590-05-06-022040	5	50	22	42	40	0,30	A	11,00	ANHX 1206...	
181115900	050A17590-06-06-022040	6	50	22	42	40	0,30	A	11,00	ANHX 1206...	
181116500	063A17590-05-06-022040	5	63	22	52	40	0,55	A	11,00	ANHX 1206...	
181116600	063A17590-07-06-022040	7	63	22	52	40	0,52	A	11,00	ANHX 1206...	
181116700	080A17590-08-06-027050	8	80	27	60	50	1,10	A	11,00	ANHX 1206...	
181116800	080A17590-10-06-027050	10	80	27	60	50	1,10	A	11,00	ANHX 1206...	
181116900	100A17590-12-06-032050	12	100	32	80	50	1,65	B	11,00	ANHX 1206...	
181117000	125A17590-14-06-040063	14	125	40	90	63	3,16	B	11,00	ANHX 1206...	

Stock item | Produto de stock | Itens de stock

Available under request (see page A-9) | Disponível sobre consulta (consulte a página A-9) | Disponible bajo consulta (mire pagina A-9)

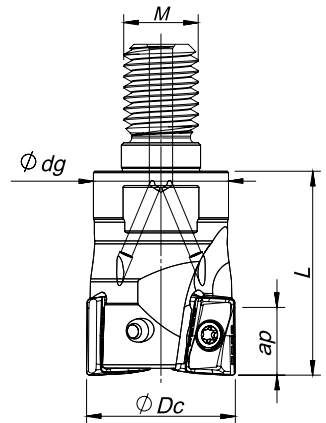

Threaded Coupling

$K_r = 90^\circ$ | $\gamma_p = -6^\circ$

Order code Código	Reference Referência Referencia		Dimensions Dimensões Dimensiones (mm)				Kg	Specifications		Insert Pastilha Inserto	Stock
			ϕDc	ϕM	ϕdg	L		Ap max			
181117100	025R17590-02-06-M12035	2	25	M12	21	35	0,09	11,00	ANHX 1206...		
181117200	032R17590-03-06-M16043	3	32	M16	29	43	0,20	11,00	ANHX 1206...		
181117300	042R17590-04-06-M16043	4	42	M16	29	43	0,26	11,00	ANHX 1206...		

Stock item | Produto de stock | Itens de stock

Available under request (see page A-9) | Disponível sobre consulta (consulte a página A-9) | Disponible bajo consulta (mire pagina A-9)

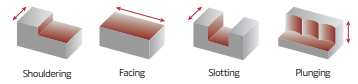

Weldon Shank
 $K_r = 90^\circ$ | $\gamma_p = -6^\circ$

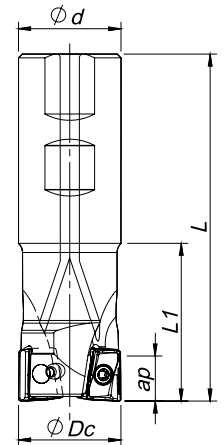

Order code Código	Reference Referência Referencia		Dimensions Dimensões Dimensiones (mm)				Kg	Specifications		Insert Pastilha Inserto	Stock
			ØDc	Ød	L	L1		Ap max			
181116000	025W17590-02-06-025110	2	25	25	110	35	0,37	11,00	ANHX 1206...		
181120600	032W17590-03-06-032150	3	32	32	150	35	0,84	11,00	ANHX 1206...		
181116100	040W17590-04-06-032150	4	40	32	150	40	0,88	11,00	ANHX 1206...		

Stock item | Produto de stock | Itens de stock

Available under request (see page A-9) | Disponível sobre consulta (consulte a página A-9) | Disponible bajo consulta (mire pagina A-9)



Cylindrical Shank
 $K_r = 90^\circ$ | $\gamma_p = -6^\circ$

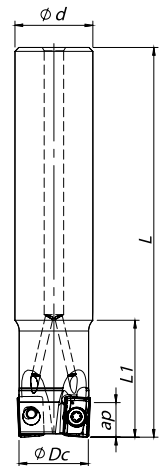

Order code Código	Reference Referência Referencia		Dimensions Dimensões Dimensiones (mm)				Kg	Specifications		Insert Pastilha Inserto	Stock
			ØDc	Ød	L	L1		Ap max			
181116300	026E17590-02-06-025200	2	26	25	200	40	0,66	11,00	ANHX 1206...		
181116200	033E17590-03-06-032250	3	33	32	250	40	1,40	11,00	ANHX 1206...		

Stock item | Produto de stock | Itens de stock

Available under request (see page A-9) | Disponível sobre consulta (consulte a página A-9) | Disponible bajo consulta (mire pagina A-9)

SPARE PARTS || Complementos | Repuestos

Cutter ØDc	Order separately			
	Insert Screw	Key (Torx)	Key (Torx - Nm)	Torque Value
E17590 - 26 - 33	P0350904	XT10	DT1020	2,0
A17590 - 40 - 100	P0350904	XT10	DT1020	2,0
A17590 - 125	P0350904	PT10	DT1020	2,0
R17590 - 25 - 42	P0350904	XT10	DT1020	2,0
W17590 - 25-40	P0350904	XT10	DT1020	2,0

Note: The toolholder is supplied with the XT/PT key. To order the DT key please check the page A-241.
Check the procedures for the clamping screws on the page A-241.

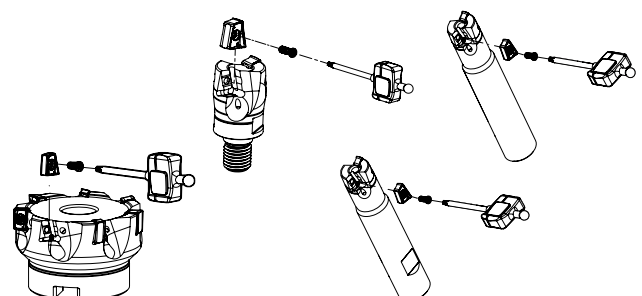

PLUS 17590

ANHX 1206.. | Inserts | Pastilhas | Plaquitras

ANHX-LS

ANHX-MP

ANHX-LS | MP

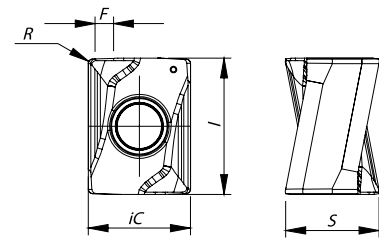

	(2) Grade code	P					M			K					S			Dimensions Dimensões Dimensiones (mm)				
		CVD	PVD				PVD			PVD					PVD							
(1) Geometry code	ISO Reference	PH5740	PH7920	PHP920	PH7930	PH7740	PH7930	PHH930	PH7740	PH5320	PH7920	PHP920	PH7930	PH7740	PH7930	PHH930	PH7740	iC	S	I	R	F
1112474	ANHX 120604 PNER-LS		⊗		⊗	⊗	⊗			⊗	⊗	⊗	⊗	⊗	⊗	⊗	9,0	8,3	12,0	0,4	1,6	
1112237	ANHX 120608 PNER-LS		⊗			⊗	⊗				⊗	⊗	⊗	⊗	⊗	⊗	9,0	8,3	12,0	0,8	1,2	
1112429	ANHX 120616 PNER-LS		⊗		⊗	⊗	⊗				⊗	⊗	⊗	⊗	⊗	⊗	9,0	8,3	12,0	1,6	0,4	
1112473	ANHX 120604 PNSR-MP			⊗		⊗			⊗	⊗	⊗	⊗	⊗	⊗			9,0	8,3	12,0	0,4	1,6	
1112238	ANHX 120608 PNSR-MP	⊗		⊗		⊗			⊗	⊗	⊗	⊗	⊗	⊗			9,0	8,3	12,0	0,8	1,2	
1112430	ANHX 120616 PNSR-MP		⊗	⊗		⊗			⊗	⊗	⊗	⊗	⊗	⊗			9,0	8,3	12,0	1,6	0,4	

⊗ First choice | Primeira opção | 1ª opción ⊗ Stock item | Produto de stock | Itens de stock ○ Available under request (see page A-9) | Disponível sobre consulta (consulte a página A-9) | Disponible bajo consulta (mire página A-9) Insert order code = (1) Geometry Code + (2) Grade Code
 ⊗ Stock available until sold out | Stock disponível até acabar o stock | Stock disponible hasta acabar el stock

RECOMMENDED CUTTING CONDITIONS | Condições de corte recomendadas | Condiciones de corte recomendables

ISO	PSM	Material	HB (Brinell)	Vc (m/min)							Feed fz (mm/t)	
				← Wear Resistance				Toughness →			ANHX 12... LS	ANHX 12... MP
				PH5320	PHP920	PH7920	PHH930	PH7930	PHS740	PH7740		
P	1	Unalloyed Steel	125-220	-	180-250	180-240	-	160-220	140-220	140-200	0,08-0,20	0,08-0,30
	2	Low-Alloyed Steel	220-280	-	160-230	160-220	-	140-200	120-200	130-180	0,08-0,20	0,08-0,25
	3	High-Alloyed Steel	280-380	-	140-220	140-210	-	120-190	100-190	100-170	0,08-0,15	0,08-0,20
M	4	SS - Ferritic / Martensitic	200-330	-	-	140-220	140-210	140-200	-	130-180	0,08-0,20	-
	5	SS - Austenitic	200-330	-	-	130-180	120-170	120-160	-	110-160	0,08-0,15	-
	6	SS - Austenitic-ferritic (Duplex)	230-260	-	-	120-160	100-150	100-140	-	90-150	0,08-0,15	-
K	7	Malleable Cast Iron	130-230	150-280	160-270	160-260	-	150-240	-	140-220	0,08-0,20	0,08-0,30
	8	Grey Cast Iron	180-245	160-320	140-250	140-240	-	140-230	-	120-210	0,08-0,20	0,08-0,25
	9	Nodular Cast iron	160-250	100-190	120-210	120-200	-	100-190	-	100-190	0,08-0,20	0,08-0,20
S	11	Heat Resistant Super Alloys	200-320	-	-		30-110	30-100	-	30-100	0,07-0,10	-

(Note 1) Cutting conditions $a_e/D_c=70\%$.

(Note 2)

Operation	a_e	Vc & fz	a_p (mm)
Slotting	100%	<20%	2,5-4,0
Shouldering	<50%	>8%	4,0-7,0
	≤25%	>12%	7,0-10,0

(Note 3)

It's possible to occur vibrations in certain cases. Please reduce depth of cut and / or reduce cutting conditions in following cases:
 - When using long shank;
 - When using long tool overhang with arbor type;
 - When application has poor clamping rigidity or when using a low rigidity machine.

GRADES SELECTION GUIDE | Guia para selecção de graus | Tabla para selección de calidades

ISO	PSM	Material	HB (Brinell)	Grades						
				← Wear Resistance			Toughness →			
				PH5320	PHP920	PH7920	PHH930	PH7930	PHS740	PH7740
P	1	Unalloyed Steel	125-220	●	●	●	●	●	●	●
	2	Low-Alloyed Steel	220-280		●	●		●	●	●
	3	High-Alloyed Steel	280-380		●	●		●	●	●
M	4	SS - Ferritic / Martensitic	200-330				●	●		●
	5	SS - Austenitic	200-330				●	●		●
	6	SS - Austenitic-ferritic (Duplex)	230-260				●	●		●
K	7	Malleable Cast Iron	130-230	●	●	●		●		●
	8	Grey Cast Iron	180-245	●	●	●		●		●
	9	Nodular Cast iron	160-250	●	●	●		●		●
S	11	Heat Resistant Super Alloys	200-320					●		●

● Good Conditions ● Average Conditions ● Difficult Conditions

CHIP-BREAKER SELECTION GUIDE | Guia de selecção do quebra-apanas | Guía de selección del rompevirutas

ISO	PSM	Material	HB (Brinell)	Chip Breaker Application	
				1 st choice	Difficult Operations
P	1	Unalloyed Steel	125-220	ANHX 12... LS	ANHX 12... MP
	2	Low-Alloyed Steel	220-280	ANHX 12... MP	-
	3	High-Alloyed Steel	280-380	ANHX 12... MP	-
M	4	SS - Ferritic / Martensitic	200-330	ANHX 12... LS	-
	5	SS - Austenitic	200-330	ANHX 12... LS	-
	6	SS - Austenitic-ferritic (Duplex)	220-260	ANHX 12... LS	-
K	7	Malleable Cast Iron	130-230	ANHX 12... LS	ANHX 12... MP
	8	Grey Cast Iron	180-245	ANHX 12... MP	-
	9	Nodular Cast iron	160-250	ANHX 12... MP	-
S	11	Heat Resistant Super Alloys	200-320	ANHX 12... LS	-

PLUNGING | Mergulho | Plunge

L ≤ 3Dc	L > 3Dc	S max.
f _z (mm/t)		$S_{max} = \sqrt{Dc \cdot Dr - Dr^2}$
0,10-0,20	0,10-0,14	

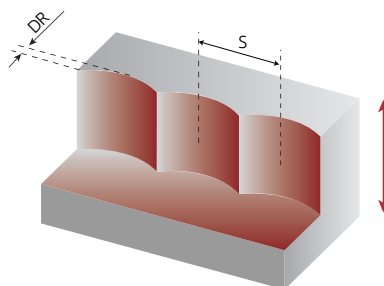

S max and DR corresponding cutting diameter Dc (mm)							
DR (mm)	Dc (mm)						
	32	40	50	63	80	100	125
1,0	5,6	6,2	7,0	7,9	8,9	9,9	11,1
2,0	7,7	8,7	9,8	11,0	12,5	14,0	15,7
3,0	9,3	10,5	11,9	13,4	15,2	17,1	19,1



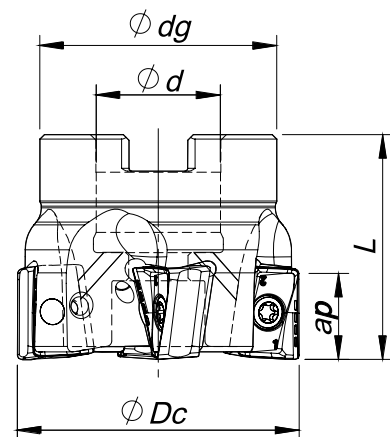

Arbor Mounting

$K_r = 90^\circ$ | $\gamma_p = -4^\circ$

Order code Código	Reference Referência Referencia		Dimensions Dimensões Dimensiones (mm)				Kg	Specifications		Insert Pastilha Inserto	Stock
			ϕDc	ϕd	ϕDg	L		Arbor Type	Ap max		
181067600	050A18190-03-04-022040	3	50	22	42	40	0,28	A	15,0	ANHX 1607...	
181067700	050A18190-04-04-022040	4	50	22	42	40	0,27	A	15,0	ANHX 1607...	
181067800	063A18190-04-04-022040	4	63	22	52	40	0,51	A	15,0	ANHX 1607...	
181067900	063A18190-06-04-022040	6	63	22	52	40	0,48	A	15,0	ANHX 1607...	
181068000	080A18190-05-04-027050	5	80	27	60	50	0,88	B	15,0	ANHX 1607...	
181051800	080A18190-07-04-027050	7	80	27	60	50	0,36	B	15,0	ANHX 1607...	
181068100	100A18190-05-04-032050	5	100	32	80	50	1,60	B	15,0	ANHX 1607...	
181068200	100A18190-08-04-032050	8	100	32	80	50	1,59	B	15,0	ANHX 1607...	
181068300	125A18190-07-04-040063	7	125	40	90	63	2,93	B	15,0	ANHX 1607...	
181068400	125A18190-10-04-040063	10	125	40	90	63	2,89	B	15,0	ANHX 1607...	
181068500	160A18190-08-04-U040063	8	160	40	110	63	4,29	C	15,0	ANHX 1607...	
181068600	160A18190-12-04-U040063	12	160	40	110	63	4,29	C	15,0	ANHX 1607...	

Stock item | Produto de stock | Itens de stock

Available under request (see page A-9) | Disponível sobre consulta (consulte a página A-9) | Disponible bajo consulta (mire pagina A-9)

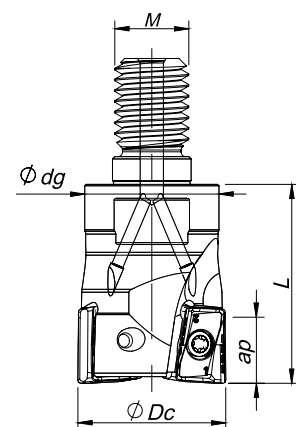

Threaded Coupling

$K_r = 90^\circ$ | $\gamma_p = -4^\circ$

Order code Código	Reference Referência Referencia		Dimensions Dimensões Dimensiones (mm)				Kg	Specifications		Insert Pastilha Inserto	Stock
			ϕDc	ϕM	ϕdg	L		Ap max			
181082800	032R18190-02-04-M16043	2	32	M16	29	43	0,20	15,0	ANHX 1607...		
181082900	040R18190-03-04-M16043	3	40	M16	29	43	0,24	15,0	ANHX 1607...		

Stock item | Produto de stock | Itens de stock

Available under request (see page A-9) | Disponível sobre consulta (consulte a página A-9) | Disponible bajo consulta (mire pagina A-9)

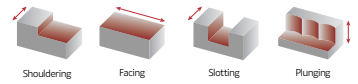

Weldon Shank
 $K_r = 90^\circ$ | $\gamma_p = -4^\circ$

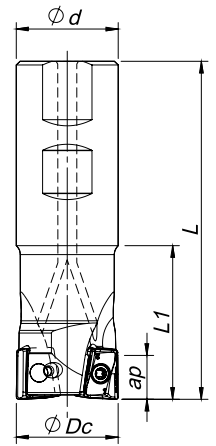

Order code Código	Reference Referência Referencia		Dimensions Dimensões Dimensiones (mm)				Kg	Specifications	Insert Pastilha Inserto	Stock
			ϕDc	ϕd	L	L1		Ap max		
181051600	032W18190-02-04-032110		32	32	110	50	0,66	15,0	ANHX 1607...	
181067500	040W18190-03-04-032115		40	32	115	40	0,66	15,0	ANHX 1607...	

Stock item | Produto de stock | Itens de stock

Available under request (see page A-9) | Disponível sobre consulta (consulte a página A-9) | Disponible bajo consulta (mire pagina A-9)

ANHX 1607.. | Inserts | Pastilhas | Plaquetas

ANHX-LP

ANHX-MP

ANHX-LN

ANHX-LP | MP | LN

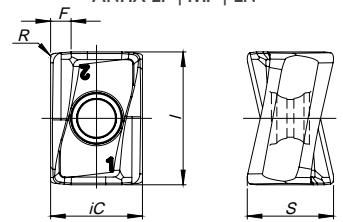

(1) Geometry code	(2) Grade code ISO Reference	P						K					N	Dimensions Dimensões Dimensiones (mm)				
		CVD	PVD					PVD					UNC					
		T9	G1	G4	T1	P3	P4	G1	G4	T1	P3	P4	10	iC	S	I	R	F
1111519	ANHX 160708 PNR-LP													11,20	10,80	16	0,8	1,4
1111596	ANHX 160712 PNR-LP													11,20	10,50	16	1,2	1,2
1111595	ANHX 160708 PNER-MP													11,20	10,80	16	0,8	1,4
1111598	ANHX 160712 PNER-MP													11,20	10,50	16	1,2	1,2
1111659	ANHX 160708 PNFR-LN													11,20	10,80	16	0,8	1,4
1111597	ANHX 160712 PNFR-LN													11,20	10,50	16	1,2	1,2

First choice | Primeira opção | 1ª opción

Stock item | Produto de stock | Itens de stock

Available under request (see page A-9) | Disponível sobre consulta (consulte a página A-9) | Disponible bajo consulta (mire pagina A-9)

Insert order code = (1) Geometry Code + (2) Grade Code

Stock available until sold out | Stock disponível até acabar o stock | Stock disponible hasta acabar el stock

A
MILLING
Overview
Face milling
Hifeed milling
Shoulder milling
Profile milling
Hardmill
Center & Chamfer
Spot face
Spare Parts
Technical Data
End Mills

PLUS 18190

SPARE PARTS | Complementos | Repuestos

Cutter ØDc	Insert Screw	Key (Torx)	Order separately		Order separately	
			Key (Torx - Nm)	Torque Value	Screw	DIN 6368 Wrench
W18190 - 32 - 40	P0401200	XT15	DT1530	3,0	-	-
R18190 - 32 - 40	P0401200	XT15	DT1530	3,0	-	-
A18190 - 50 - 63	P0401200	XT15	DT1530	3,0	-	-
A18190 - 80	P0401200	XT15	DT1530	3,0	J0123510	SD6368-12
A18190 - 100	P0401200	XT15	DT1530	3,0	J0164110	SD6368-16
A18190 - 125	P0401200	PT15	DT1530	3,0	J0204610	SD6368-20
A18190 - 160	P0401200	PT15	DT1530	3,0	-	-

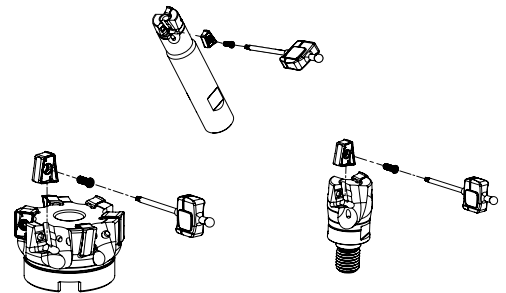

Note: The toolholder is supplied with the XT/PT key. To order the DT key please check the page A-241.
Check the procedures for the clamping screws on the page A-241.

RECOMMENDED CUTTING CONDITIONS | Condições de corte recomendadas | Condiciones de corte recomendadas

ISO	PSM	Material	HB (Brinell)	Vc (m/min)							Feed fz (mm/t)		
				← Wear Resistance				Toughness →			ANHX 12... LP	ANHX 12... MP	ANHX 12... LN
				PH0910	PH7910	PHP920	PH7920	PHP930	PH7930	PHS740			
P	1	Unalloyed Steel	125-220	-	180-250	180-250	180-240	160-230	160-220	140-220	0,10-0,25	0,10-0,25	-
	2	Low-Alloyed Steel	220-280	-	160-230	160-230	160-220	140-210	140-200	120-200	0,10-0,25	0,10-0,25	-
	3	High-Alloyed Steel	280-380	-	140-220	140-220	140-210	120-200	120-190	100-190	0,10-0,20	0,10-0,20	-
K	7	Malleable Cast Iron	130-230	-	180-300	160-270	160-260	150-250	150-240	-	0,10-0,25	0,10-0,25	-
	8	Grey Cast Iron	180-245	-	160-250	140-250	140-240	140-230	140-230	-	0,10-0,25	0,10-0,25	-
	9	Nodular Cast iron	160-250	-	150-200	120-210	120-200	100-200	100-190	-	0,10-0,20	0,10-0,25	-
N	10	Aluminium and Non Ferrous	30-130	100-2000	-	-	-	-	-	-	-	-	0,10-0,40

(Note 1)
Cutting conditions $a_e/D_c=70\%$.

(Note 2)

Operation	a_e	Vc & fz	a_p (mm)
Slotting	100%	<20%	2,0-4,5
Shouldering	<50%	>8%	6,0-8,0
	≤25%	>12%	8,0-15,0

(Note 3)

It's possible to occur vibrations in certain cases. Please reduce depth of cut and / or reduce cutting conditions in following cases:

- When using long shank;
- When using long tool overhang with arbor type;
- When application has poor clamping rigidity or when using a low rigidity machine.

GRADES SELECTION GUIDE | Guia para selecção de graus | Guía para selección de calidades

ISO	PSM	Material	HB (Brinell)	Grades						
				← Wear Resistance				Toughness →		
				PH0910	PH7910	PHP920	PH7920	PHP930	PH7930	PHS740
P	1	Unalloyed Steel	125-220	●	✓	✓	✓	✓	✓	✓
	2	Low-Alloyed Steel	220-280		✓	✓	✓	✓	✓	✓
	3	High-Alloyed Steel	280-380		✓	✓	✓	✓	✓	✓
K	7	Malleable Cast Iron	130-230		✓	✓	✓	✓	✓	
	8	Grey Cast Iron	180-245		✓	✓	✓	✓	✓	
	9	Nodular Cast iron	160-250		✓	✓	✓	✓	✓	
N	10	Aluminium and Non Ferrous	30-130	✓						

- Good Conditions
- Average Conditions
- Difficult Conditions

CHIP-BREAKER SELECTION GUIDE | Guia para aplicações do quebra-apanas | Guía para aplicación del rompevirutas

ISO	PSM	Material	HB (Brinell)	Chip Breaker Application	
				1 st choice	Difficult Operations
P	1	Unalloyed Steel	125-220	ANHX 16... LP	ANHX 16... MP
	2	Low-Alloyed Steel	220-280	ANHX 16... LP	ANHX 16... MP
	3	High-Alloyed Steel	280-380	ANHX 16... LP	ANHX 16... MP
K	7	Malleable Cast Iron	130-230	ANHX 16... LP	ANHX 16... MP
	8	Grey Cast Iron	180-245	ANHX 16... LP	ANHX 16... MP
	9	Nodular Cast iron	160-250	ANHX 16... LP	ANHX 16... MP
N	10	Aluminium and Non Ferrous	30-130	ANHX 16... LN	-

PLUNGING | Mergulho | Plunge

L ≤ 3Dc	L > 3Dc	S max.
f _z (mm/t)		
0,10-0,20	0,10-0,14	$S_{max} = \sqrt{D_c \cdot DR - DR^2}$

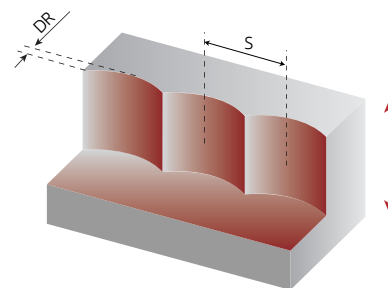

S max and DR corresponding cutting diameter Dc (mm)								
DR (mm)	Dc (mm)							
	32	40	50	63	80	100	125	160
1,0	5,6	6,2	7,0	7,9	8,9	9,9	11,1	12,6
2,0	7,7	8,7	9,8	11,0	12,5	14,0	15,7	17,8
3,0	9,3	10,5	11,9	13,4	15,2	17,1	19,1	21,7
4,0	10,6	12,0	13,6	15,4	17,4	19,6	22,0	25,0
5,0	11,6	13,2	15,0	17,0	19,4	21,8	24,5	27,8



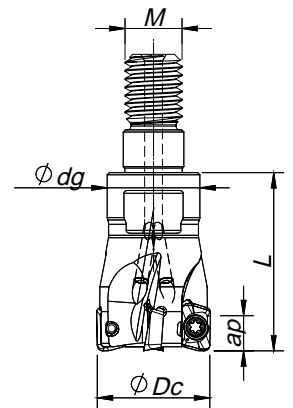
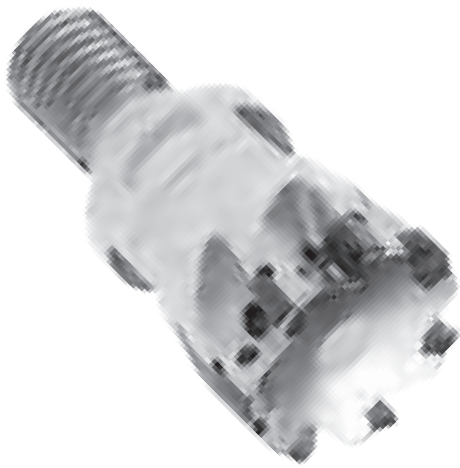

Threaded Coupling

$K_r=90^\circ$ | $\gamma_p=+4^\circ$

Order code Código	Reference Referência Referencia		Dimensions Dimensões Dimensiones (mm)				Kg	Max ap (mm)			Insert Pastilha Inserto	Stock
			ϕDc	ϕM	ϕdg	L		LP LN	HF	MH		
181120400	010R20090-02-04-M06020	2	10	M6	9,8	20	0,01	4,00	0,30	2,00	XP... 0602...	
181112800	011R20090-02-04-M06020	2	11	M6	9,8	20	0,01	4,00	0,30	2,00	XP... 0602...	
181120500	012R20090-03-04-M06020	3	12	M6	9,8	20	0,02	4,00	0,30	2,00	XP... 0602...	
181112900	013R20090-03-04-M06020	3	13	M6	9,8	20	0,02	4,00	0,30	2,00	XP... 0602...	
181087500	016R20090-04-04-M08025	4	16	M8	13,0	25	0,03	4,00	0,30	2,00	XP... 0602...	
181113000	017R20090-04-04-M08025	4	17	M8	13,0	25	0,04	4,00	0,30	2,00	XP... 0602...	
181087600	020R20090-05-04-M10030	5	20	M10	18,0	30	0,06	4,00	0,30	2,00	XP... 0602...	
181087700	025R20090-07-04-M12030	7	25	M12	21,0	30	0,09	4,00	0,30	2,00	XP... 0602...	
181087800	032R20090-08-04-M16035	8	32	M16	29,0	35	0,19	4,00	0,30	2,00	XP... 0602...	

Stock item | Produto de stock | Itens de stock

Available under request (see page A-8) | Disponível sobre consulta (consulte a página A-8) | Disponible bajo consulta (mire página A-8)

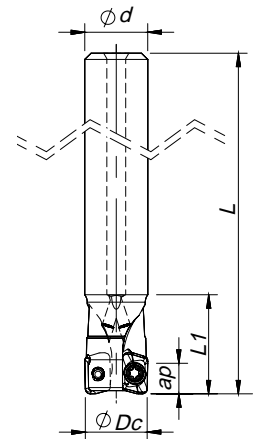

Cylindrical Shank

$K_r=90^\circ$ | $\gamma_p=+4^\circ$

Order code Código	Reference Referência Referencia		Dimensions Dimensões Dimensiones (mm)				Kg	Max ap (mm)			Insert Pastilha Inserto	Stock
			ϕDc	ϕd	L	L1		LP LN	HF	MH		
181087100	010E20090-02-04-010055	2	10	10	55	16	0,03	4,00	0,30	2,00	XP... 0602...	
181108300	010E20090-02-04-010100	2	10	10	100	25	0,03	4,00	0,30	2,00	XP... 0602...	
181087200	012E20090-02-04-012080	2	12	12	80	17	0,06	4,00	0,30	2,00	XP... 0602...	
181109900	012E20090-03-04-012120	3	12	12	120	30	0,06	4,00	0,30	2,00	XP... 0602...	
181087300	016E20090-03-04-016090	3	16	16	90	20	0,12	4,00	0,30	2,00	XP... 0602...	
181087400	016E20090-04-04-016090	4	16	16	90	20	0,11	4,00	0,30	2,00	XP... 0602...	
181097100	017E20090-05-04-016090	5	17	16	90	35	0,11	4,00	0,30	2,00	XP... 0602...	
181097200	021E20090-05-04-020090	5	21	20	90	35	0,13	4,00	0,30	2,00	XP... 0602...	

Stock item | Produto de stock | Itens de stock

Available under request (see page A-8) | Disponível sobre consulta (consulte a página A-8) | Disponible bajo consulta (mire página A-8)



XP... 0602... || Inserts | Pastilhas | Plaquetas

XPET-LP



XPET-LN



XPET-LP | LN

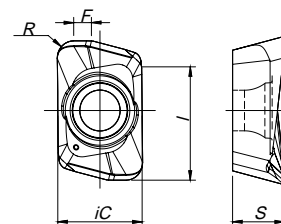

XPET-HF
(HiFeed geometry)



XPET-HF

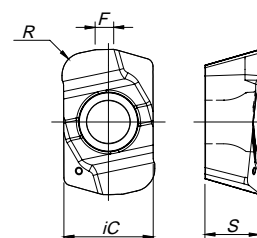

XPHW-MH
(finishing geometry)



XPHW-MH

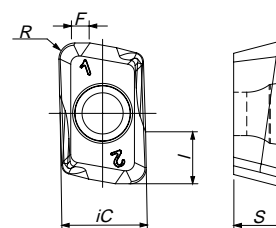

		P				M	K	N	S	H		Dimensions Dimensões Dimensiones (mm)					
		PVD				PVD	CVD	PVD	UNC	PVD	PVD						
		X4	X6	T1	P4	X9	T1	P4	10	X9	X4						X6
⁽¹⁾ Geometry code	ISO Reference	PHH603	PHH910	PHP920	PHP930	PHH930	PHP920	PHP930	PH0910	PHH930	PHH603	PHH910	iC	S	I	R	F
1112002	XPET 060204 PDER-LP			⊗	⊗	⊗	⊗	⊗		⊗			3,90	2,40	5,30	0,40	0,80
1112003	XPET 060208 PDER-LP			⊗	⊗	⊗	⊗	⊗		⊗			3,90	2,40	5,30	0,80	0,70
1112004	XPET 060216 PDER-LP			⊗	⊗		⊗	⊗					3,90	2,40	5,30	1,60	0,60
1112579	XPET 060202 PDFR-LN								⊗				3,90	2,40	5,10	0,20	0,95
1112580	XPET 060204 PDFR-LN								⊗				3,90	2,40	5,10	0,40	0,80
1112049	XPET 060210 ZER-HF			⊗	⊗	⊗	⊗	⊗		⊗			3,90	2,40	-	1,00	0,80
1112259	XPHW 060208 ZER-MH	⊗	⊗								⊗	⊗	3,90	2,40	2,40	0,80	0,70

⊗ First choice | Primeira opção | 1ª opción ⊗ Stock item | Produto de stock | Itens de stock ○ Available under request (see page A-9) | Disponível| sobre consulta (consulte a página A-9) | Disponible bajo consulta (mire página A-9) Insert order code = (1) Geometry Code + (2) Grade Code

LINEPRO 20090

A

SPARE PARTS | Complementos | Repuestos

MILLING

Cutter ØDc	Insert Screw	Key (Torx)	Order separately	
			Key (Torx - Nm)	Torque Value
E20090 - 10	P0180300	XT06IP	DT0606IP	0,6
E20090 - 12-16	P0180400	XT06IP	DT0606IP	0,6
R20090 - 12-16	P0180400	XT06IP	DT0606IP	0,6

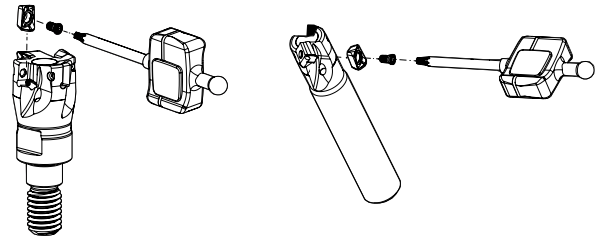

Note: The toolholder is supplied with the XT/PT key. To order the DT key please check the page A-241. Check the procedures for the clamping screws on the page A-241.

Overview

Face milling

Hi-feed milling

GRADES SELECTION GUIDE | Guia para selección de graus | Tabla para selección de calidades

ISO	PSM	Material	HB (Brinell)	Grades					
				← Wear Resistance			Toughness →		
				PH0910	PHH603	PHH910	PHP920	PHP930	PHH930
P	1	Unalloyed Steel	125-220	●	●	●	✓	✓	
	2	Low-Alloyed Steel	220-280			✓	✓	✓	
	3	High-Alloyed Steel	280-380		✓	✓	✓	✓	
M	4	SS - Ferritic / Martensitic	200-330						✓
	5	SS - Austenitic	200-330						✓
	6	SS - Austenitic-ferritic (Duplex)	230-260						✓
K	7	Malleable Cast Iron	130-230				✓	✓	
	8	Grey Cast Iron	180-245				✓	✓	
	9	Nodular Cast iron	160-250				✓	✓	
N	10	Aluminium and Non Ferrous	30-130	✓					
S	11	Heat Resistant Super Alloys	200-320						✓
H	12	Hardened Steels	40-55 HRC		✓	✓			

- Good Conditions
- Average Conditions
- Difficult Conditions

Center & Chamfer

Spot face

Spare Parts

Technical Data

End Mills

RECOMMENDED CUTTING CONDITIONS | Condições de corte recomendadas | Condiciones de corte recomendables

ISO	PSM	Material	HB (Brinell)	Vc (m/min)					
				← Wear Resistance				Toughness →	
				PH0910	PHH603	PHH910	PHP920	PHP930	PHH930
P	1	Unalloyed Steel	125-220	-	-	-	180-250	160-230	-
	2	Low-Alloyed Steel	220-280	-	-	160-270	160-230	140-210	-
	3	High-Alloyed Steel	280-380	-	180-310	140-230	140-220	120-200	-
M	4	SS - Ferritic / Martensitic	200-330	-	-	-	-	-	140-210
	5	SS - Austenitic	200-330	-	-	-	-	-	120-170
	6	SS - Austenitic-ferritic (Duplex)	230-260	-	-	-	-	-	100-150
K	7	Malleable Cast Iron	130-230	-	-	-	160-270	150-250	-
	8	Grey Cast Iron	180-245	-	-	-	140-250	140-230	-
	9	Nodular Cast iron	160-250	-	-	-	120-210	100-200	-
N	10	Aluminium and Non Ferrous	30-130	100-2000	-	-	-	-	-
S	11	Heat Resistant Super Alloys	200-320	-	-	-	-	-	30-110
H	12	Hardened Steels	40-55 HRC	-	70-270	70-260	-	-	-

ISO	PSM	Material	HB (Brinell)	Feed fz (mm/t)			
				XPET 06...LP	XPET 06...LN	XPET 06...HF	XPHW 06...MH
P	1	Unalloyed Steel	125-220	0,05-0,07	-	0,40-0,80	-
	2	Low-Alloyed Steel	220-280	0,05-0,07	-	0,40-0,80	0,05-0,12
	3	High-Alloyed Steel	280-380	0,05-0,07	-	0,40-0,60	0,05-0,12
M	4	SS - Ferritic / Martensitic	200-330	0,05-0,07	-	0,40-0,80	-
	5	SS - Austenitic	200-330	0,05-0,07	-	0,40-0,60	-
	6	SS - Austenitic-ferritic (Duplex)	230-260	0,05-0,07	-	0,40-0,60	-
K	7	Malleable Cast Iron	130-230	0,05-0,07	-	0,40-0,80	-
	8	Grey Cast Iron	180-245	0,05-0,07	-	0,40-0,80	-
	9	Nodular Cast iron	160-250	0,05-0,07	-	0,40-0,80	-
N	10	Aluminium and Non Ferrous	30-130	-	0,05-0,07	-	-
S	11	Heat Resistant Super Alloys	200-320	0,05-0,07	-	0,40-0,60	-
H	12	Hardened Steels	40-55 HRC	-	-	-	0,03-0,10

(Note 1) Cutting conditions $a_e/D_c=70\%$.

(Note 2) It's possible to occur vibrations in certain cases. Please reduce depth of cut and / or reduce cutting conditions in following cases:

- When using long shank;
- When using long tool overhang with arbor type;
- When application has poor clamping rigidity or when using a low rigidity machine.

(Note 3) PH5... and PHS... can be used wet or dry. PH7... use only air.

(Note 4) It's possible to occur vibrations in certain cases. Please reduce depth of cut and / or reduce cutting conditions in following cases:

- When using long shank;
- When using long tool overhang with arbor type;
- When application has poor clamping rigidity or when using a low rigidity machine.

Operation	a_e	Vc & fz	a_p (mm)
Slotting	100%	<20%	1,0-3,0
Shouldering	<50%	>8%	1,0-4,0
	≤25%	>12%	1,0-4,0

LINEPRO 20090

CHIP-BREAKER SELECTION GUIDE | Guia para aplicações do quebra- aparas | Guía para aplicación del rompevirutas

ISO	PSM	Material	HB (Brinell)	Chip-Breaker Application	
				1st choice	Difficult Operations
P	1	Unalloyed Steel	125-220	XPET 06... LP/HF	-
	2	Low-Alloyed Steel	220-280	XPET 06... LP/HF	XPHW 06... MH
	3	High-Alloyed Steel	280-380	XPET 06... LP/HF	XPHW 06... MH
M	4	SS - Ferritic / Martensitic	200-330	XPET 06... LP/HF	-
	5	SS - Austenitic	200-330	XPET 06... LP/HF	-
	6	SS - Austenitic-ferritic (Duplex)	230-260	XPET 06... LP/HF	-
K	7	Malleable Cast Iron	130-230	XPET 06... LP/HF	-
	8	Grey Cast Iron	180-245	XPET 06... LP/HF	-
	9	Nodular Cast iron	160-250	XPET 06... LP/HF	-
N	10	Aluminium and Non Ferrous	30-130	XPET 06... LN	-
S	11	Heat Resistant Super Alloys	200-320	XPET 06... LP/HF	-
H	12	Hardened Steels	40-55 HRC	XPHW 06... MH	-

PROGRAMMING DATA | Dados para programação | Datos para la programación

Insert	Programming Data		
	Rp	X	b
XPET 06 HF	1,1	0,84	2,3

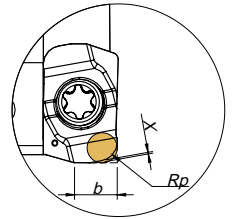

RAMPING AND HELICAL INTERPOLATION

Descida em rampa e interpolação helicoidal | Bajada en rampa e interpolación circular

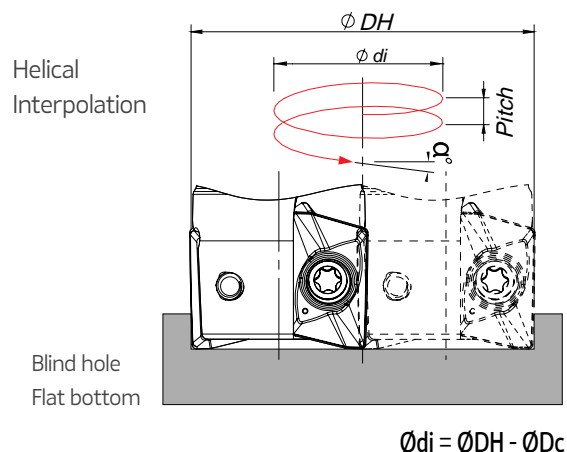
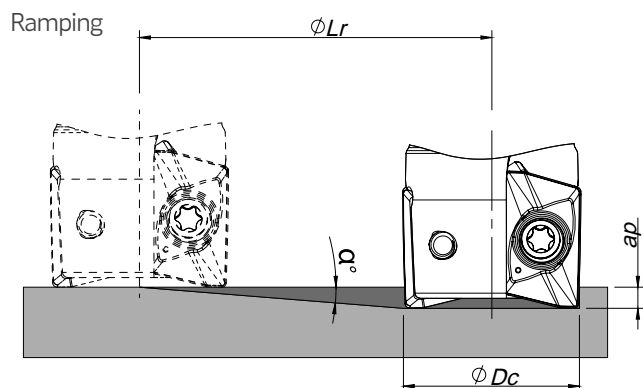

ϕD_c	Ramping			Helical Interpolation		
				Diameter for Blind Hole, Flat Bottom Face (1)		Max Pitch/Rev.
	Max Ramp a°	Max a_p	Min L_r	ϕDH_{min}	ϕDH_{max}	
10	5,5	4,0	41,5	17,2 -	- 18,4	2,2 2,5
12	4,0	4,0	57,2	21,2 -	- 22,4	2,0 2,3
16	2,5	4,0	91,6	29,2 -	- 30,4	1,8 2,0
17	2,2	4,0	104,1	31,2 -	- 32,4	1,7 1,9
20	1,9	4,0	120,6	37,2 -	- 38,4	1,8 1,9
21	1,6	4,0	143,2	39,2 -	- 40,4	1,6 1,7
25	1,3	4,0	171,0	47,2 -	- 48,4	1,6 1,7
32	1,0	4,0	229,2	61,2 -	- 62,4	1,6 1,7

(1) using LP insert with radius 0,8 mm

Note: During helical interpolation do not exceed maximum pitch

When using HF insert or other different insert radius to calculate the ϕDH_{min} and ϕDH_{max} use the equation below:

- Minimum Diameter: $\phi DH_{min} = 2 \times (\phi D_c - (R \text{ corner radius} + F \text{ width of edge wiper}))$

- Maximum Diameter: $\phi DH_{max} = 2 \times (\phi D_c - R \text{ corner radius})$

(On HF insert the corner radius should be corner radius programming)



A

MILLING

Overview

Face milling

Hifeed milling

Shoulder milling

Profile milling

Hardmill

Center & Chamfer

Spot face

Spare Parts

Technical Data

End Mills

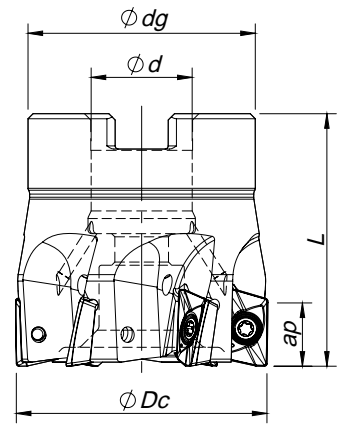
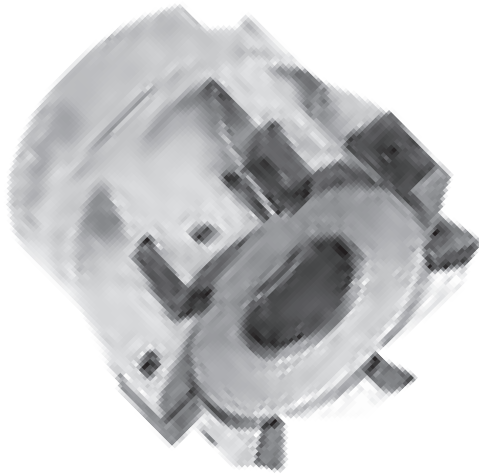

Arbor Mounting

$K_r=90^\circ$ | $\gamma_p=+8^\circ$

Order code Código	Reference Referência Referencia		Dimensions Dimensões Dimensiones (mm)				Kg	Max ap (mm)			Arbor Style	Insert Pastilha Inserto	Stock
			ϕDc	ϕd	ϕdg	L		LP/MP	HF	MH			
181088600	040A20190-06-08-016040		40	16	36	40	0,22	10,0	0,80	3,00	A	XP... 1003...	
181088700	050A20190-07-08-022040		50	22	42	40	0,31	10,0	0,80	3,00	A	XP... 1003...	
181088800	063A20190-08-08-022040		63	22	52	40	0,43	10,0	0,80	3,00	A	XP... 1003...	

Stock item | Produto de stock | Itens de stock

Available under request (see page A-8) | Disponível sobre consulta (consulte a página A-8) | Disponible bajo consulta (mire pagina A-8)

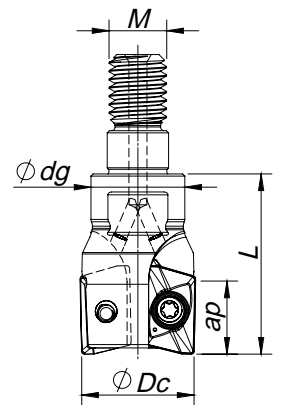
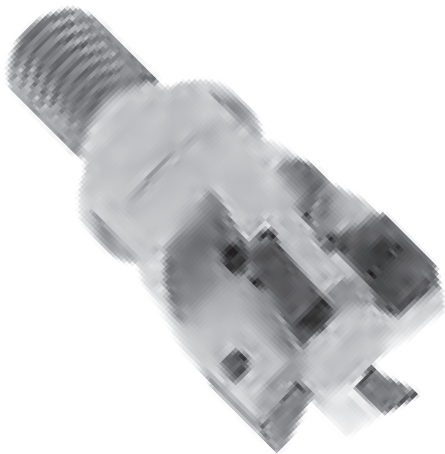

Threaded Coupling

$K_r=90^\circ$ | $\gamma_p=+5^\circ \sim +6^\circ$

Order code Código	Reference Referência Referencia		Dimensions Dimensões Dimensiones (mm)				Kg	Max ap (mm)			Insert Pastilha Inserto	Stock
			ϕDc	ϕM	ϕdg	L		LP/MP	HF	MH		
181088200	016R20190-02-05-M08025		16	M8	14	25	0,03	10,0	0,80	3,00	XP... 1003...	
181088300	020R20190-03-05-M10030		20	M10	18	30	0,06	10,0	0,80	3,00	XP... 1003...	
181088400	025R20190-04-05-M12035		25	M12	21	35	0,12	10,0	0,80	3,00	XP... 1003...	
181088500	032R20190-05-06-M16035		32	M16	29	35	0,15	10,0	0,80	3,00	XP... 1003...	
181149100	040R20190-06-08-M16043		40	M16	29	43	0,25	10,0	0,80	3,00	XP... 1003...	

Stock item | Produto de stock | Itens de stock

Available under request (see page A-8) | Disponível sobre consulta (consulte a página A-8) | Disponible bajo consulta (mire pagina A-8)

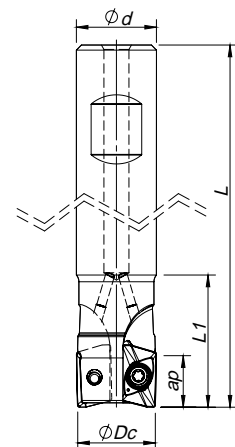

Weldon Shank

$K_r=90^\circ$ | $\gamma_p=+5^\circ\sim 8^\circ$

Order code Código	Reference Referência Referencia		Dimensions Dimensões Dimensiones (mm)				Kg	Max ap (mm)			Insert Pastilha Inserto	Stock
			ØDc	Ød	L	L1		LP/MP	HF	MH		
181087900	016W20190-02-05-016085	2	16	16	85	32	0,10	10,0	0,80	3,00	XP... 1003...	
181100600	016W20190-02-05-016150	2	16	16	150	70	0,13	10,0	0,80	3,00	XP... 1003...	
181108600	017W20190-02-05-016150	2	17	16	150	36	0,14	10,0	0,80	3,00	XP... 1003...	
181088000	020W20190-03-05-020090	3	20	20	90	28	0,21	10,0	0,80	3,00	XP... 1003...	
181100700	020W20190-03-05-020150	3	20	20	150	70	0,26	10,0	0,80	3,00	XP... 1003...	
181108700	022W20190-03-05-020150	3	22	20	150	70	0,30	10,0	0,80	3,00	XP... 1003...	
181088100	025W20190-04-05-025095	4	25	25	95	30	0,33	10,0	0,80	3,00	XP... 1003...	
181100800	025W20190-04-05-025150	4	25	25	150	80	0,36	10,0	0,80	3,00	XP... 1003...	
181108800	027W20190-04-05-025150	4	27	25	150	80	0,38	10,0	0,80	3,00	XP... 1003...	
181085400	032W20190-04-08-032110	4	32	32	110	50	0,55	10,0	0,80	3,00	XP... 1003...	

Stock item | Produto de stock | Itens de stock

Available under request (see page A-8) | Disponível sobre consulta (consulte a página A-8) | Disponible bajo consulta (mire pagina A-8)

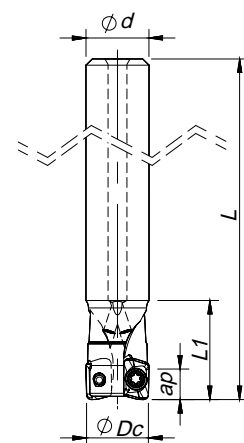

Cylindrical Shank

$K_r=90^\circ$ | $\gamma_p=+4^\circ$

Order code Código	Reference Referência Referencia		Dimensions Dimensões Dimensiones (mm)				Kg	Max ap (mm)			Insert Pastilha Inserto	Stock
			ØDc	Ød	L	L1		LP/MP	HF	MH		
181171700	016E20190-02-05-016085	2	16	16	85	32	0,10	10,0	0,8	3,0	XP...1003...	
181173000	016E20190-02-05-016150	2	16	16	150	70	0,13	10,0	0,8	3,0	XP...1003...	
181171600	020E20190-03-05-020090	3	20	20	90	28	0,21	10,0	0,8	3,0	XP...1003...	
181171800	020E20190-03-05-020150	3	20	20	150	70	0,26	10,0	0,8	3,0	XP...1003...	
181171400	025E20190-04-05-025095	4	25	25	95	30	0,33	10,0	0,8	3,0	XP...1003...	
181172900	025E20190-04-05-025150	4	25	25	150	80	0,36	10,0	0,8	3,0	XP...1003...	

Stock item | Produto de stock | Itens de stock

Available under request (see page A-8) | Disponível sobre consulta (consulte a página A-8) | Disponible bajo consulta (mire pagina A-8)

LINEPRO 20190

XP... 1003... | Inserts | Pastilhas | Plaquetas

A

MILLING

Overview

Face milling

Hi-feed milling

Shoulder milling

Profile milling

Hardmill

Center & Chamfer

Spot face

Spare Parts

Technical Data

End Mills

XPET-LP
(PHH-PHP grade)



XPET-MP
(PHH-PHP grade)

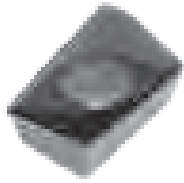

XPET-LN

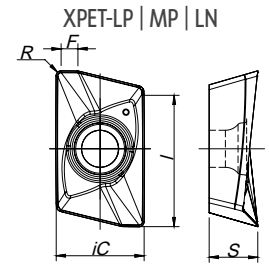

XPET-HF
(HiFeed geometry)

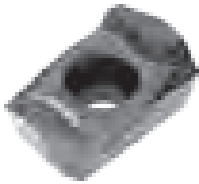

XPHW-MH
(finishing geometry)

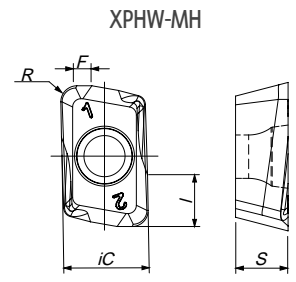
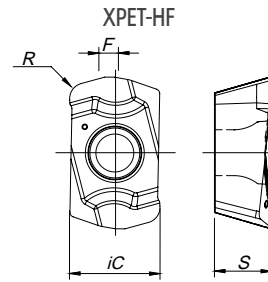

XPHW-R Z1 **NEW**

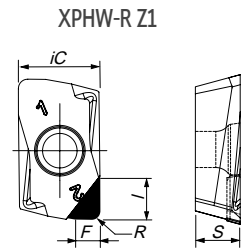
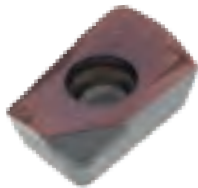

(1) Geometry code	(2) Grade code	P		M	K			N	S	H		Dimensions Dimensões Dimensiones (mm)										
		CVD	PVD			PVD	CVD	PVD		UNC	PCD	PVD	PVD	iC	S	I	R	F				
		T9	G1	X5	T1	P4	X9	L5	L9	X5	T1	P4	10	D6	X9	X4	X6					
1113132	XPET 100302 PDER-LP																	6,95	3,96	10,50	0,20	1,50
1111980	XPET 100304 PDER-LP																	6,95	3,96	10,50	0,40	1,30
1111981	XPET 100308 PDER-LP																	6,95	3,96	10,50	0,80	1,40
1112022	XPET 100316 PDER-LP																	6,95	3,96	10,50	1,60	0,80
1111982	XPET 100304 PDSR-MP																	6,95	3,96	10,50	0,40	1,10
1111983	XPET 100308 PDSR-MP																	6,95	3,96	10,50	0,80	1,35
1111984	XPET 100304 PDFR-LN																	6,95	3,96	10,50	0,40	0,75
1112906	XPET 100308 PDFR-LN																	6,95	3,96	10,50	0,80	1,05
1111985	XPET 100312 PDFR-LN																	6,95	3,96	10,50	1,20	0,75
1112376	XPET 100312 ZDR-HF																	6,95	3,96	-	1,20	1,50
1112500	XPHW 100308 ZER-MH																	6,95	3,60	3,00	0,80	1,30
1112736	XPHW 100310 ZER-MH																	6,95	3,60	3,00	1,00	0,35
1112735	XPHW 100320 ZER-MH																	6,95	3,60	3,00	1,20	1,10
1112556	XPHW 100308 R Z1																	6,95	3,60	3,80	0,80	2,30

⊕ First choice | Primeira opção | 1ª opción ⊕ Stock item | Produto de stock | Itens de stock

○ Available under request (see page A-9) | Disponível sobre consulta (consulte a página A-9) | Disponible bajo consulta (mire página A-9)

Insert order code = (1) Geometry Code + (2) Grade Code

SPARE PARTS | Complementos | Repuestos

Cutter ØDc	Insert Screw	Key (Torx)	Order separately	
			Key (Torx - Nm)	Torque Value
A20190 - 40-63	P0250704	XT08	DT0812	1,2
R20190 - 16	P0250503	XT08	DT0812	1,2
R20190 - 20-40	P0250704	XT08	DT0812	1,2
W20190 - 16-17	P0250503	XT08	DT0812	1,2
W20190 - 20-32	P0250704	XT08	DT0812	1,2
E20190 - 16	P0250503	XT08	DT0812	1,2
E20190 - 20-25	P0250704	XT08	DT0812	1,2

Note: The toolholder is supplied with the XT/PT key. To order the DT key please check the page A-241.
Check the procedures for the clamping screws on the page A-241.

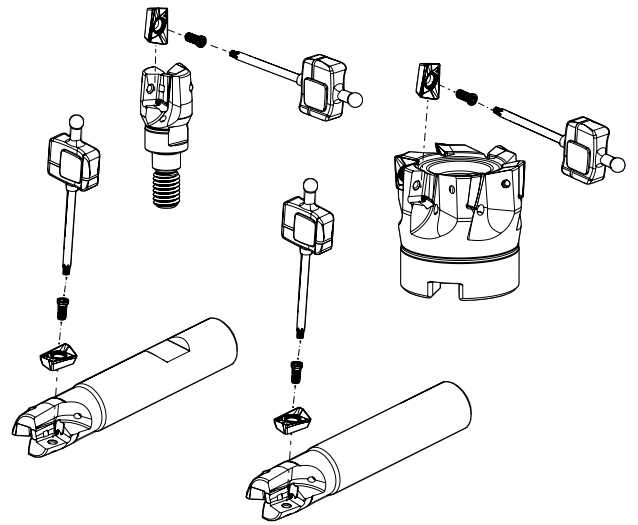

PROGRAMMING DATA | Dados para programação | Datos para la programación

Insert	Programming Data		
	Rp	X	b
XPET 10 HF	1,6	0,33	3,45

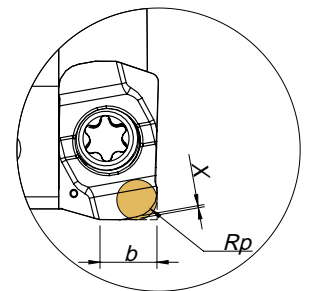

RAMPING AND HELICAL INTERPOLATION

Descida em rampa e interpolação helicoidal | Bajada en rampa e interpolación circular

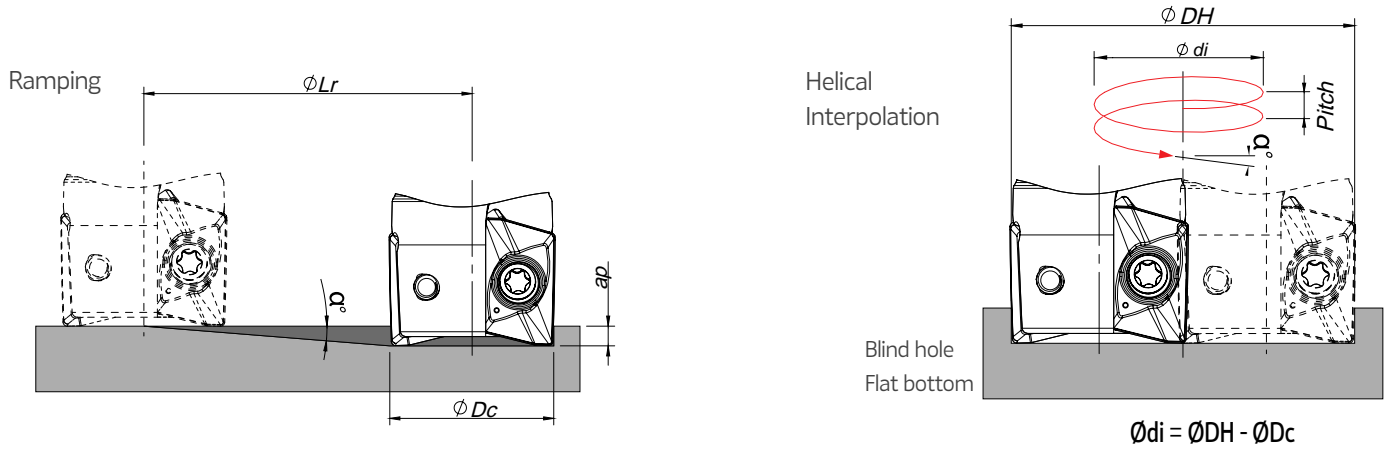

ϕDc	Ramping			Helical Interpolation		
	Max Ramp a°	Max ap	Min Lr	Diameter for Blind Hole, Flat Bottom Face (1)		Max Pitch/Rev.
				ϕDH_{min}	ϕDH_{max}	
16	7,5	10,0	76,0	27,6 -	- 30,4	4,8 6,0
17	7,0	10,0	81,4	29,6 -	- 32,4	4,9 5,9
20	5,0	10,0	114,3	35,6 -	- 38,4	4,3 5,1
22	4,5	10,0	127,1	39,6 -	- 42,4	4,3 5,0
25	3,5	10,0	163,5	45,6 -	- 48,4	4,0 4,5
27	3,0	10,0	190,8	49,6 -	- 52,4	3,7 4,2
32	2,5	10,0	229,0	59,6 -	- 62,4	3,8 4,2
40	1,7	10,0	336,9	75,6 -	- 78,4	3,3 3,6
50	1,3	10,0	440,7	95,6 -	- 98,4	3,2 3,4
63	1,0	10,0	572,9	121,6 -	- 124,4	3,2 3,4

(1) using LP insert with radius 0,8 mm

Note: During helical interpolation do not exceed maximum pitch

When using HF insert or other different insert radius to calculate the ϕDH_{min} and ϕDH_{max} use the equation below:

- Minimum Diameter: $\phi DH_{min} = 2 \times (\phi Dc - (R \text{ corner radius} + F \text{ width of edge wiper}))$

- Maximum Diameter: $\phi DH_{max} = 2 \times (\phi Dc - R \text{ corner radius})$

CHIP-BREAKER SELECTION GUIDE | Guia para aplicações do quebra- aparas | Guía para aplicación del rompevirutas

ISO	PSM	Material	HB (Brinell)	Chip-Breaker Application	
				1st choice	Difficult Operations
P	1	Unalloyed Steel	125-220	XPET 10 ... LP/HF	XPET 10 ... MP
	2	Low-Alloyed Steel	220-280	XPET 10 ... LP/HF	XPET 10 ... MP
	3	High-Alloyed Steel	280-380	XPET 10 ... MP/HF	-
M	4	SS - Ferritic / Martensitic	200-330	XPET 10 ... LP/HF	-
	5	SS - Austenitic	200-330	XPET 10 ... LP/HF	-
	6	SS - Austenitic-ferritic (Duplex)	230-260	XPET 10 ... LP/HF	-
K	7	Malleable Cast Iron	130-230	XPET 10 ... LP/HF	XPET 10 ... MP
	8	Grey Cast Iron	180-245	XPET 10 ... MP/HF	-
	9	Nodular Cast iron	160-250	XPET 10 ... MP/HF	-
N	10	Aluminium and Non Ferrous	30-130	XPET 10 ... LN/R Z1	-
S	11	Heat Resistant Super Alloys	200-320	XPET 10 ... LP/HF	-
H	12	Hardened Steels	40-55 HRC	XPHW 10 ... MH	-

GRADES SELECTION GUIDE | Guia para selecção de graus | Tabla para selección de calidades

ISO	PSM	Material	HB (Brinell)	Grades							PCD		
				← Wear Resistance				Toughness →					
				PH0910	PH5705	PHH603	PHP910	PHP920	PHP930	PHH930		PH5740	PHS740
P	1	Unalloyed Steel	125-220	●	●	●	●	●	●	●	●	●	
	2	Low-Alloyed Steel	220-280				●	●	●			●	
	3	High-Alloyed Steel	280-380			●	●	●	●			●	
M	4	SS - Ferritic / Martensitic	200-330							●			
	5	SS - Austenitic	200-330							●			
	6	SS - Austenitic-ferritic (Duplex)	230-260							●			
K	7	Malleable Cast Iron	130-230		●		●	●	●		●		
	8	Grey Cast Iron	180-245		●		●	●	●		●		
	9	Nodular Cast iron	160-250		●		●	●	●		●		
N	10	Aluminium and Non Ferrous	30-130	●								●	
S	11	Heat Resistant Super Alloys	200-320								●		
H	12	Hardened Steels	40-55 HRC			●							

● Good Conditions

● Average Conditions

● Difficult Conditions

RECOMMENDED CUTTING CONDITIONS | Condições de corte recomendadas | Condiciones de corte recomendables

ISO	PSM	Material	HB (Brinell)	Vc (m/min)									PCD
				← Wear Resistance						Toughness →			
				PH0910	PH5705	PHH603	PHP910	PHP920	PHP930	PHH930	PH5740	PHS740	
P	1	Unalloyed Steel	125-220	-	-	-	180-250	180-250	160-230	-	-	140-220	-
	2	Low-Alloyed Steel	220-280	-	-	-	160-240	160-230	140-210	-	-	120-200	-
	3	High-Alloyed Steel	280-380	-	-	180-310	140-230	140-220	120-200	-	-	100-190	-
M	4	SS - Ferritic / Martensitic	200-330	-	-	-	-	-	-	140-210	-	-	-
	5	SS - Austenitic	200-330	-	-	-	-	-	-	120-170	-	-	-
	6	SS - Austenitic-ferritic (Duplex)	230-260	-	-	-	-	-	-	100-150	-	-	-
K	7	Malleable Cast Iron	130-230	-	160-290	-	180-300	160-270	150-250	-	160-260	-	-
	8	Grey Cast Iron	180-245	-	170-320	-	160-250	140-250	140-230	-	140-240	-	-
	9	Nodular Cast iron	160-250	-	140-200	-	150-210	120-210	100-200	-	120-200	-	-
N	10	Aluminium and Non Ferrous	30-130	100-2000	-	-	-	-	-	-	-	-	100-3000
S	11	Heat Resistant Super Alloys	200-320	-	-	-	-	-	-	30-110	-	-	-
H	12	Hardened Steels	40-55 HRC	-	-	70-270	-	-	-	-	-	-	-

(Note 1): Cutting conditions $a_e/D_c=70\%$.

(Note 2): PH5... and PHS... can be used wet or dry. PH7... use only air.

(Note 3):

Operation	a_e	Vc & fz	a_p (mm)
Slotting	100%	<20%	2,0-4,0
Shouldering	<50%	>8%	3,0-6,0
	≤25%	>12%	7,0-9,0

(Note 4):

It's possible to occur vibrations in certain cases. Please reduce depth of cut and / or reduce cutting conditions in following cases:

- When using long shank;
- When using long tool overhang with arbor type;
- When application has poor clamping rigidity or when using a low rigidity machine.

Feed fz (mm/t)				
XPET 10... LP	XPET 10... MP	XPET 10... LN/R Z1	XPET 10... HF	XPHW 10... MH
0,08-0,20	0,10-0,25	-	0,40-0,80	0,10-0,25
0,08-0,20	0,10-0,20	-	0,40-0,80	0,10-0,25
0,08-0,15	0,10-0,20	-	0,40-0,60	0,10-0,25
0,08-0,20	0,10-0,20	-	0,40-0,70	-
0,08-0,20	0,10-0,20	-	0,40-0,70	-
0,08-0,15	0,10-0,20	-	0,40-0,60	-
0,08-0,20	0,10-0,25	-	0,50-0,80	-
0,08-0,20	0,10-0,25	-	0,50-0,80	-
0,08-0,20	0,10-0,20	-	0,50-0,60	-
-	-	0,07-0,25	-	-
0,05-0,07	-	-	0,40-0,60	-
-	-	-	-	0,08-0,15



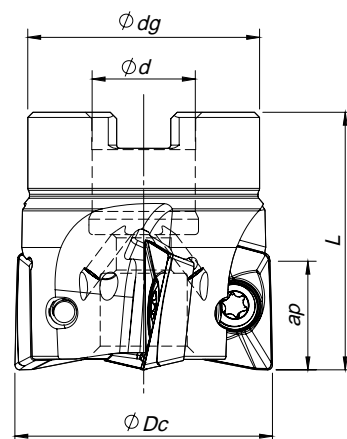
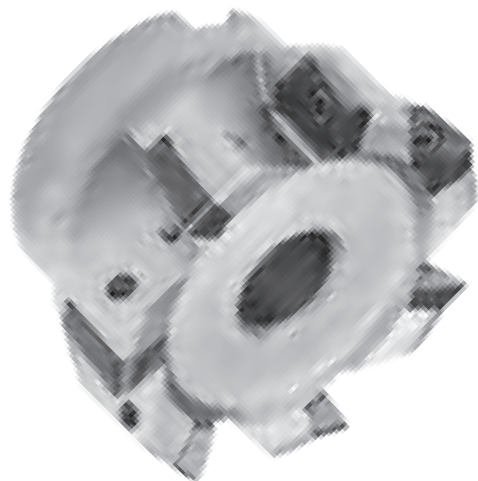

Arbor Mounting

$K_r=90^\circ$ | $\gamma_p=+7^\circ \sim +8^\circ$

Order code Código	Reference Referência Referencia		Dimensions Dimensões Dimensiones (mm)				Kg	Specifications		Insert Pastilha Inserto	Stock
			ϕDc	ϕd	ϕdg	L		Arbor Type	Ap max (mm)		
181090900	040A20290-04-07-016040	4	40	16	32	40	0,18	A	17,0	XPET 1706...	
181091000	050A20290-05-08-022040	5	50	22	42	40	0,29	A	17,0	XPET 1706...	
181091100	063A20290-06-08-027040*	6	63	27	52	40	0,53	A	17,0	XPET 1706...	
181091200	080A20290-07-08-027050	7	80	27	60	50	0,92	A	17,0	XPET 1706...	
181091300	100A20290-08-08-032050	8	100	32	80	50	1,68	A	17,0	XPET 1706...	
181091400	125A20290-09-08-040063	9	125	40	90	63	3,01	A	17,0	XPET 1706...	

Stock item | Produto de stock | Itens de stock

Available under request (see page A-8) | Disponível sobre consulta (consulte a página A-8) | Disponible bajo consulta (mire pagina A-8)

* For shank assembly a DIN 6920 screw is needed.

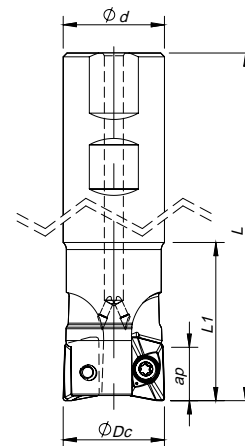

Weldon Shank

$K_r=90^\circ$ | $\gamma_p=+6^\circ \sim +7^\circ$

Order code Código	Reference Referência Referencia		Dimensions Dimensões Dimensiones (mm)				Kg	Specifications		Insert Pastilha Inserto	Stock
			ϕDc	ϕd	L	L1		Ap max (mm)			
181090500	032W20290-02-06-032110	2	32	32	110	50	0,56	17,0	XPET 1706...		
181090600	032W20290-02-06-032200	2	32	32	200	60	1,10	17,0	XPET 1706...		
181090700	040W20290-03-07-032115	3	40	32	115	50	0,67	17,0	XPET 1706...		
181090800	040W20290-03-07-032200	3	40	32	200	60	1,19	17,0	XPET 1706...		

Stock item | Produto de stock | Itens de stock

Available under request (see page A-8) | Disponível sobre consulta (consulte a página A-8) | Disponible bajo consulta (mire pagina A-8)

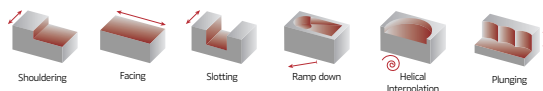

XPET 1706... | Inserts | Pastilhas | Plaquetas

XPET-LP



XPET-MP



XPET-LN



XPET-LP | MP | LN | LS

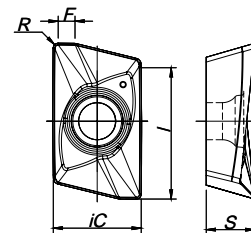

XPET-LS (PHH grade) **NEW**



(1) Geometry code	(2) Grade code	P		M		K				N	S			Dimensions Dimensões Dimensiones (mm)						
		CVD	PVD			PVD		CVD		PVD		UNC	PVD			iC	S	I	R	F
		T9	T1	G6	X9	G6	L5	L9	T1	G6	10	X9	G6							
1111986	XPET 170608 PDER-LP		⊗	⊗		⊗			⊗	⊗			⊗	11,30	6,35	17,50	0,80	1,80		
1111987	XPET 170616 PDER-LP		⊗	⊗		⊗			⊗	⊗			⊗	11,30	6,35	17,50	1,60	1,20		
1111988	XPET 170608 PDSR-MP	⊗	⊗	⊗			⊗	⊗	⊗	⊗				11,30	6,35	17,50	0,80	1,80		
1111989	XPET 170616 PDSR-MP		⊗	⊗			⊗	⊗	⊗	⊗				11,30	6,35	17,50	1,60	1,00		
1111990	XPET 170608 PDFR-LN										⊗			11,30	6,35	17,50	0,80	1,20		
1111991	XPET 170620 PDFR-LN										⊗			11,30	6,35	17,50	2,00	1,00		
1111992	XPET 170632 PDFR-LN										⊗			11,30	6,35	17,50	3,20	0,80		
NEW 1112223	XPET 170608 PDER-LS				⊗	⊗						⊗	⊗	11,3	6,35	17,5	0,8	1,8		

⊗ First choice | Primeira opção | 1ª opción ⊗ Stock item | Produto de stock | Itens de stock ○ Available under request (see page A-9) | Disponível sobre consulta (consulte a página A-9) | Disponible bajo consulta (mire página A-9) Insert order code = (1) Geometry Code + (2) Grade Code

SPARE PARTS | Complementos | Repuestos

Cutter ØDc	Order separately				
	Insert Screw	Key (Torx)	Key (Torx - Nm)	Torque Value	Retaining Screw
W20290 - 32-40	P0451001	XT20	DT2050	5	-
A20290 - 40-80	P0451001	XT20	DT2050	5	-
A20290 - 100	P0451001	PT20	DT2050	5	D1603500
A20290 - 125	P0451001	PT20	DT2050	5	D2004000

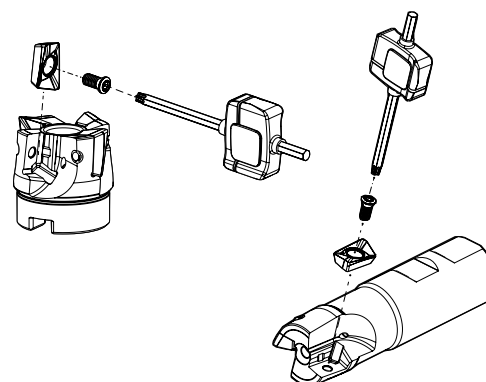

Note: The toolholder is supplied with the XT/PT key. To order the DT key please check the page A-241.
Check the procedures for the clamping screws on the page A-241.

LINEPRO 20290

A

GRADES SELECTION GUIDE | Guia para selecção de graus | Tabla para selección de calidades

MILLING

Overview

Face milling

Hi-feed milling

Shoulder milling

Profile milling

Hardmill

Center & Chamfer

Spot face

Spare Parts

Technical Data

End Mills

ISO	PSM	Material	HB (Brinell)	Grades							
				← Wear Resistance				Toughness →			
				PH0910	PH5705	PHP920	PHP930	PHH930	PH5740	PHS740	PH7740
P	1	Unalloyed Steel	125-220	●	●	●	●	●	●	●	●
	2	Low-Alloyed Steel	220-280			●	●			●	●
	3	High-Alloyed Steel	280-380			●	●			●	●
M	4	SS - Ferritic / Martensitic	200-330					●			●
	5	SS - Austenitic	200-330					●			●
	6	SS - Austenitic-ferritic (Duplex)	230-260					●			●
K	7	Malleable Cast Iron	130-230		●	●	●		●		●
	8	Grey Cast Iron	180-245		●	●	●		●		●
	9	Nodular Cast iron	160-250		●	●	●		●		●
N	10	Aluminium and Non Ferrous	30-130	●							
S	11	Heat Resistant Super Alloys	200-320					●			●

● Good Conditions

● Average Conditions

● Difficult Conditions

CHIP-BREAKER SELECTION GUIDE | Guia para aplicações do quebra-apanas | Guía para aplicación del rompevirutas

ISO	PSM	Material	HB (Brinell)	Chip-Breaker Application	
				1st choice	Difficult Operations
				P	1
2	Low-Alloyed Steel	220-280	XPET 17... LP		XPET 17... MP
3	High-Alloyed Steel	280-380	XPET 17... MP		-
M	4	SS - Ferritic / Martensitic	200-330	XPET 17... LS	XPET 17... LP
	5	SS - Austenitic	200-330	XPET 17... LS	XPET 17... LP
	6	SS - Austenitic-ferritic (Duplex)	230-260	XPET 17... LS	XPET 17... LP
K	7	Malleable Cast Iron	130-230	XPET 17... LP	XPET 17... MP
	8	Grey Cast Iron	180-245	XPET 17... MP	-
	9	Nodular Cast iron	160-250	XPET 17... MP	-
N	10	Aluminium and Non Ferrous	30-130	XPET 17... LN	-
S	11	Heat Resistant Super Alloys	200-320	XPET 17... LS	XPET 17... LP

RECOMMENDED CUTTING CONDITIONS | Condições de corte recomendadas | Condiciones de corte recomendables

ISO	PSM	Material	HB (Brinell)	Vc (m/min)				
				← Wear Resistance				
				PH0910	PH5705	PHP920	PHP930	PHH930
P	1	Unalloyed Steel	125-220	-	-	180-250	160-230	-
	2	Low-Alloyed Steel	220-280	-	-	160-230	140-210	-
	3	High-Alloyed Steel	280-380	-	-	140-220	120-200	-
M	4	SS - Ferritic / Martensitic	200-330	-	-	-	-	140-210
	5	SS - Austenitic	200-330	-	-	-	-	120-170
	6	SS - Austenitic-ferritic (Duplex)	230-260	-	-	-	-	100-150
K	7	Malleable Cast Iron	130-230	-	160-290	160-270	-	-
	8	Grey Cast Iron	180-245	-	170-320	140-250	-	-
	9	Nodular Cast iron	160-250	-	140-200	120-210	-	-
N	10	Aluminium and Non Ferrous	30-130	100-2000	-	-	-	-
S	11	Heat Resistant Super Alloys	200-320	-	-	-	-	30-110

(Note 1) Cutting conditions ae/DC=70%

(Note 2) Cutting conditions should be adjusted according to the machine and work rigidity.

(Note 3):

Operation	ae	Vc & fz	ap (mm)
Slotting	100%	<20%	2,0-6,0
Shouldering	<50%	>8%	7,0-13,0
	≤25%	>12%	13,0-16,0

(Note 4) It's possible to occur vibrations in certain cases.

Please reduce depth of cut and / or reduce cutting conditions in following cases:

- When using long shank;
- When using long tool overhang with arbor type;
- When application has poor clamping rigidity or when using a low rigidity machine.

RAMPING AND HELICAL INTERPOLATION

Descida em rampa e interpolação helicoidal | Bajada en rampa e interpolación circular

Ramping

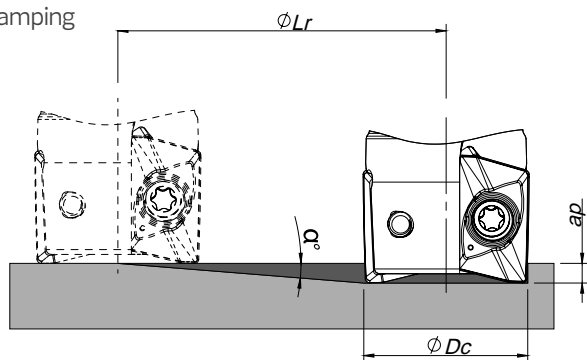

Helical Interpolation

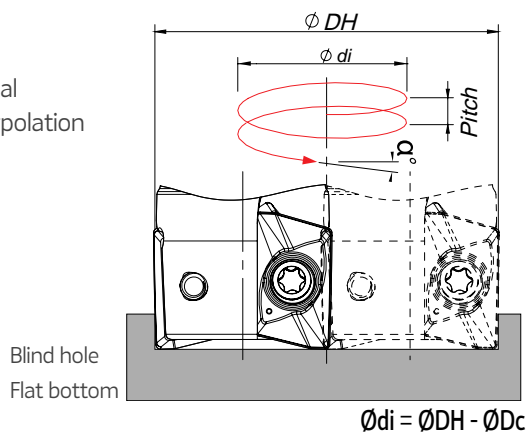

$$\text{Ødi} = \text{ØDH} - \text{ØDc}$$

ØDc	Ramping			Helical Interpolation		
	Max Ramp a°	Max ap	Min Lr	Diameter for Blind Hole, Flat Bottom Face (1)		Max Pitch/Rev.
				ØDHmin	ØDHmax	
32	3,8	17,0	255,9	58,8 -	- 62,4	5,6 6,3
40	2,7	17,0	360,5	74,8 -	- 78,4	5,2 5,7
50	2,0	17,0	486,8	94,8 -	- 98,4	4,9 5,3
63	1,5	17,0	649,2	120,8 -	- 124,4	4,8 5,0
80	1,0	17,0	973,9	154,8 -	- 158,4	4,1 4,3
100	0,8	17,0	1217,5	194,8 -	- 198,4	4,2 4,3
125	0,7	17,0	1498,4	244,8 -	- 248,4	4,3 4,4

(1) using LP insert with radius 0,8 mm

Note: During helical interpolation do not exceed maximum pitch

When using HF insert or other different insert radius to calculate the ØDHmin and ØDHmax use the equation below:

- Minimum Diameter: $\text{ØDHmin} = 2 \times (\text{ØDc} - (\text{R corner radius} + \text{F width of edge wiper}))$

- Maximum Diameter: $\text{ØDHmax} = 2 \times (\text{ØDc} - \text{R corner radius})$

Vc (m/min)			Feed fz (mm/t)			
Toughness →						
PH5740	PHS740	PH7740	XPET 17... LP	XPET 17... MP	XPET 17... LN	XPET 17... LS
-	140-220	140-200	0,10-0,35	0,10-0,35	-	-
-	120-200	130-180	0,10-0,35	0,10-0,35	-	-
-	100-190	100-170	0,10-0,30	0,10-0,30	-	-
-	-	130-180	0,10-0,30	-	-	0,10-0,35
-	-	110-160	0,10-0,30	-	-	0,10-0,30
-	-	90-150	0,10-0,25	-	-	0,10-0,25
160-260	-	140-220	0,10-0,35	0,10-0,35	-	-
140-240	-	120-210	0,10-0,35	0,10-0,35	-	-
120-200	-	100-190	0,10-0,30	0,10-0,30	-	-
-	-	-	-	-	0,10-0,35	-
-	-	30-100	0,10-0,20	-	-	0,10-0,20



A

MILLING

Overview

Face milling

Hifeed milling

Shoulder milling

Profile milling

Hardmill

Center & Chamfer

Spot face

Spare Parts

Technical Data

End Mills

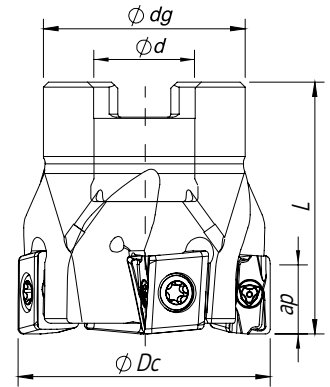
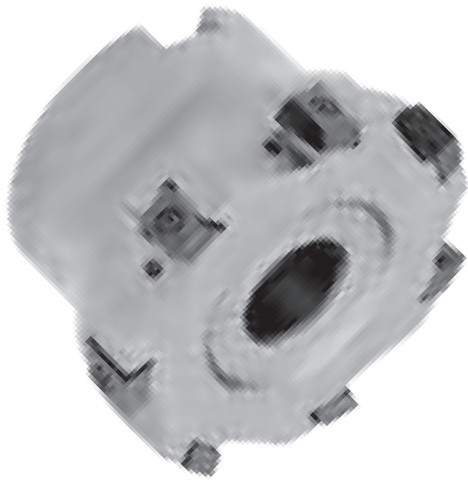

Arbor Mounting

$K_r=90^\circ$ | $\gamma_p=-4^\circ$

Order code Código	Reference Referência Referencia		Dimensions Dimensões Dimensiones (mm)				Kg	Specifications		Insert	Stock
			ϕDc	ϕd	ϕDg	L		Ap max (mm)	Arbor Type		
181144400	040A90090-04-04-016040	4	40	16	36	40	0,24	7,0	A	LNXT 0904...	
181144500	050A90090-05-04-022040	5	50	22	40	40	0,32	7,0	A	LNXT 0904...	
181144600	063A90090-07-04-022040	7	63	22	48	40	0,54	7,0	A	LNXT 0904...	
181146600	063A90090-10-04-022040	10	63	22	48	40	0,54	7,0	A	LNXT 0904...	

Stock item | Produto de stock | Itens de stock

Available under request (see page A-8) | Disponível sobre consulta (consulte a página A-8) | Disponible bajo consulta (mire pagina A-8)

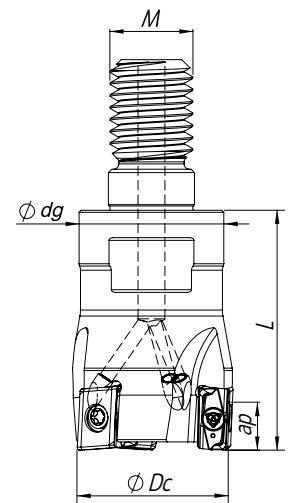

Threaded Coupling

$K_r=90^\circ$ | $\gamma_p=-4^\circ$

Order code Código	Reference Referência Referencia		Dimensions Dimensões Dimensiones (mm)				Kg	Specifications		Insert	Stock
			ϕDc	ϕM	ϕdg	L		Ap max (mm)	Arbor Type		
181144200	025R90090-03-04-M12035	3	25	12	21	35	0,10	7,0	LNXT 0904...		
181144300	032R90090-04-04-M16040	4	32	16	29	40	0,21	7,0	LNXT 0904...		

Stock item | Produto de stock | Itens de stock

Available under request (see page A-8) | Disponível sobre consulta (consulte a página A-8) | Disponible bajo consulta (mire pagina A-8)



Weldon Shank
 $K_r = 90^\circ$ | $\gamma_p = -4^\circ \sim -6^\circ$

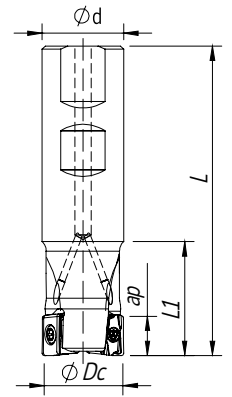

Order code Código	Reference Referência Referencia		Dimensions Dimensões Dimensiones (mm)				Kg	Specifications	Insert	Stock
			ϕD_c	ϕd	L	L1		Ap max (mm)		
181109400	016W90090-02-06-016090	2	16	16	90	25	0,12	7,0	LNXT 0904...	
181109500	025W90090-03-04-025095	3	25	25	95	30	0,31	7,0	LNXT 0904...	
181144100	032W90090-04-04-032110	4	32	32	110	30	0,61	7,0	LNXT 0904...	

Stock item | Produto de stock | Itens de stock

Available under request (see page A-8) | Disponível sobre consulta (consulte a página A-8) | Disponible bajo consulta (mire pagina A-8)



Cylindrical Shank
 $K_r = 90^\circ$ | $\gamma_p = -4^\circ$

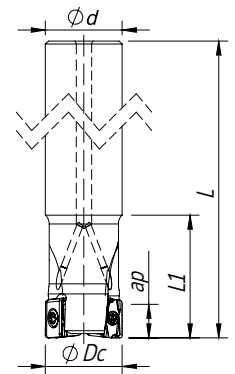

Order code Código	Reference Referência Referencia		Dimensions Dimensões Dimensiones (mm)				Kg	Specifications	Insert	Stock
			ϕD_c	ϕd	L	L1		Ap max (mm)		
NEW 181158800	020E90090-02-04-020150	2	20	20	150	30	0,15	7,0	LNXT 0904...	
181148100	025E90090-03-04-025200	3	25	25	200	30	0,31	7,0	LNXT 0904...	
181148200	032E90090-04-04-032250	4	32	32	250	30	0,78	7,0	LNXT 0904...	

Stock item | Produto de stock | Itens de stock

Available under request (see page A-8) | Disponível sobre consulta (consulte a página A-8) | Disponible bajo consulta (mire pagina A-8)

SPARE PARTS | Complementos | Repuestos

Cutter ØDc	Insert Screw	Key (Torx)	Order separately	
			Key (Torx - Nm)	Torque Value
E90090 - 25-32	P0250700	XT07	DT0709	1,2
W90090 - 16-32	P0250700	XT07	DT0709	1,2
A90090 - 40-63	P0250700	XT07	DT0709	1,2
R90090 - 25-32	P0250700	XT07	DT0709	1,2

Note: The toolholder is supplied with the XT/PT key. To order the DT key please check the page A-241.
Check the procedures for the clamping screws on the page A-241.

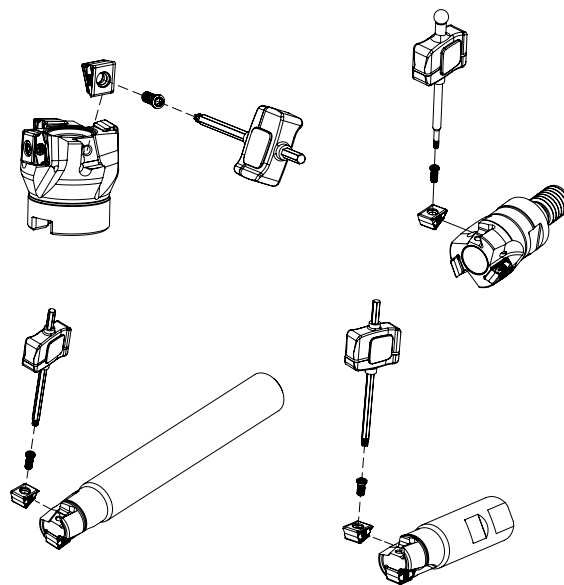

LNXT 0904... | Inserts | Pastilhas | Plaquitas

LNXT-MP

LNXT-LS
(PHH grade)

NEW



LNXT-MP | LS

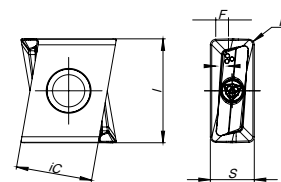

Geometry code	ISO Reference	P		M	K		S	Dimensions Dimensões Dimensiones (mm)						
		CVD	PVD	PVD	CVD	PVD	PVD	iC	S	I	R	F		
(1)	(2) Grade code	T9	T1	G6	X9	L6	T1	G6	X9					
PH5740	PH920	PH740	PH930	PH520	PH920	PH740	PH930							
1112225	LNXT 090404 PNER-MP	⊗	⊗	⊗	⊗	⊗	⊗	⊗	⊗	9,4	4,5	9,0	0,4	-
1112226	LNXT 090408 PNER-MP	⊗	⊗	⊗	⊗	⊗	⊗	⊗	⊗	9,4	4,5	9,0	0,8	-
NEW 1112868	LNXT 090404 PNER-LS				⊗				⊗	9,4	4,5	9,0	0,8	-

⊗ First choice | Primeira opção | 1ª opción ⊗ Stock item | Produto de stock | Itens de stock ○ Available under request (see page A-9) | Disponível sobre consulta (consulte a página A-9) | Disponible bajo consulta (mire pagina A-9) Insert order code = (1) Geometry Code + (2) Grade Code

GRADES SELECTION GUIDE | Guia para selecção de graus | Tabla para selección de calidades

ISO	PSM	Material	HB (Brinell)	Grades				
				← Wear Resistance			Toughness →	
				PH5320	PHP920	PHH930	PHS740	PH7740
P	1	Unalloyed Steel	125-220	●	●	●	●	●
	2	Low-Alloyed Steel	220-280		●		●	●
	3	High-Alloyed Steel	280-380		●		●	●
M	4	SS - Ferritic / Martensitic	200-330			●		
	5	SS - Austenitic	200-330			●		
	6	SS - Austenitic-ferritic (Duplex)	230-260			●		
K	7	Malleable Cast Iron	130-230	●	●			●
	8	Grey Cast Iron	180-245	●	●			●
	9	Nodular Cast iron	160-250	●	●			●
S	11	Heat Resistant Super Alloys	200-320			●		

● Good Conditions ● Average Conditions ● Difficult Conditions

RECOMMENDED CUTTING CONDITIONS | Condições de corte recomendadas | Condiciones de corte recomendables

ISO	PSM	Material	HB (Brinell)	Vc (m/min)					Feed fz (mm/t)	
				← Wear Resistance			Toughness →		LNXT 09... MP	LNXT 09... LS
				PH5320	PHP920	PHH930	PHS740	PH7740		
P	1	Unalloyed Steel	125-220	-	180-250	-	140-220	140-200	0,08-0,25	-
	2	Low-Alloyed Steel	220-280	-	160-230	-	120-200	130-180	0,08-0,25	-
	3	High-Alloyed Steel	280-380	-	140-220	-	100-190	100-170	0,08-0,15	-
M	4	SS - Ferritic / Martensitic	200-330	-	-	140-210	-	-	0,08-0,25	0,08-0,25
	5	SS - Austenitic	200-330	-	-	120-170	-	-	0,08-0,20	0,08-0,20
	6	SS - Austenitic-ferritic (Duplex)	230-260	-	-	100-150	-	-	0,08-0,15	0,08-0,20
K	7	Malleable Cast Iron	130-230	150-280	160-270	-	-	140-220	0,08-0,30	-
	8	Grey Cast Iron	180-245	160-320	140-250	-	-	120-210	0,08-0,25	-
	9	Nodular Cast iron	160-250	100-190	120-210	-	-	100-190	0,08-0,20	-
S	11	Heat Resistant Super Alloys	200-320	-	-	30-110	-	-	-	-

(Note 1) Cutting conditions $a_e/D_c=70\%$.

(Note 2) It's possible to occur vibrations in certain cases. Please reduce depth of cut and / or reduce cutting conditions in following cases:

- When using long shank;
- When using long tool overhang with arbor type;
- When application has poor clamping rigidity or when using a low rigidity machine.



A

MILLING

Overview

Face milling

Hi-feed milling

Shoulder milling

Profile milling

Hardmill

Center & Chamfer

Spot face

Spare Parts

Technical Data

End Mills

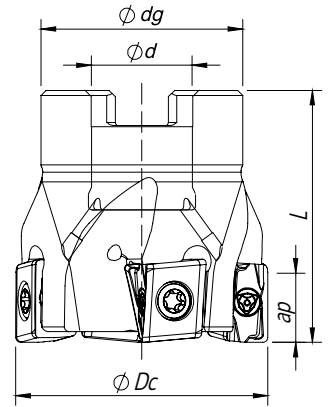
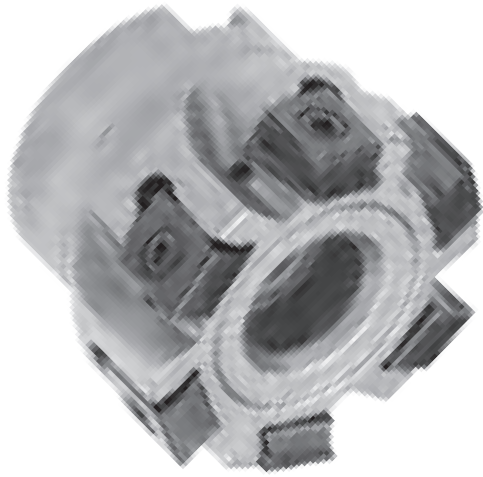

Arbor Mounting
 $K_r=90^\circ$ | $\gamma_p=-4^\circ$

Order code Código	Reference Referência Referencia		Dimensions Dimensões Dimensiones (mm)				Kg	Specifications		Insert	Stock
			ϕDc	ϕd	ϕdg	L		Ap max (mm)	Arbor Type		
181118800	040A90190-04-04-016040	4	40	16	32	40	0,17	11	A	LNXT 1306...	
181118900	040A90190-05-04-016040	5	40	16	32	40	0,18	11	A	LNXT 1306...	
181111200	050A90190-05-04-022040	5	50	22	42	40	0,27	11	A	LNXT 1306...	
181111300	050A90190-06-04-022040	6	50	22	42	40	0,28	11	A	LNXT 1306...	
181119000	063A90190-06-04-022040	6	63	22	52	40	0,52	11	A	LNXT 1306...	
181119100	063A90190-08-04-022040	8	63	22	52	40	0,52	11	A	LNXT 1306...	
181119200	080A90190-07-04-027050	7	80	27	60	50	0,88	11	B	LNXT 1306...	
181119300	080A90190-10-04-027050	10	80	27	60	50	0,86	11	B	LNXT 1306...	
181119400	100A90190-09-04-032050	9	100	32	80	50	1,56	11	B	LNXT 1306...	
181119500	100A90190-13-04-032050	13	100	32	80	50	1,56	11	B	LNXT 1306...	
181119600	125A90190-11-04-040063	11	125	40	90	63	2,87	11	B	LNXT 1306...	
181119700	125A90190-16-04-040063	16	125	40	90	63	2,86	11	B	LNXT 1306...	

Stock item | Produto de stock | Itens de stock

Available under request (see page A-8) | Disponível sobre consulta (consulte a página A-8) | Disponible bajo consulta (mire página A-8)

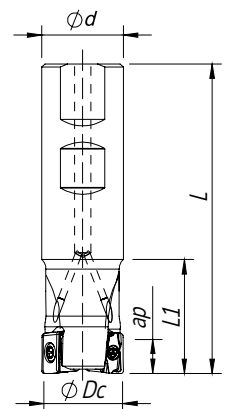

Weldon Shank
 $K_r=90^\circ$ | $\gamma_p=-4^\circ$

Order code Código	Reference Referência Referencia		Dimensions Dimensões Dimensiones (mm)				Kg	Specifications	Insert	Stock
			ϕDc	ϕd	L	L1		Ap max (mm)		
181118300	025W90190-02-04-025095	2	25	25	95	45	0,29	11	LNXT 1306...	
181109800	032W90190-03-04-032110	3	32	32	110	50	0,55	11	LNXT 1306...	
181118400	040W90190-04-04-032110	4	40	32	110	50	0,60	11	LNXT 1306...	

Stock item | Produto de stock | Itens de stock

Available under request (see page A-8) | Disponível sobre consulta (consulte a página A-8) | Disponible bajo consulta (mire página A-8)



Cylindrical Shank
 $K_r = 90^\circ$ | $\gamma_p = -4^\circ$

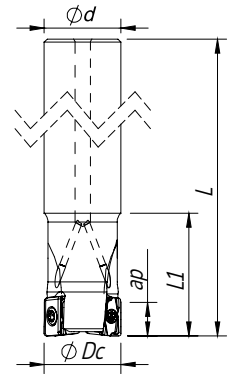

Order code Código	Reference Referência Referencia		Dimensions Dimensões Dimensiones (mm)				Kg	Specifications	Insert	Stock
			ØDc	Ød	L	L1		Ap max (mm)		
181118500	025E90190-02-04-025200	2	25	25	200	40	0,66	11	LNXT 1306...	
181118600	032E90190-03-04-032250	3	32	32	250	50	1,37	11	LNXT 1306...	
181118700	040E90190-04-04-032250	4	40	32	250	50	1,42	11	LNXT 1306...	

Stock item | Produto de stock | Itens de stock

Available under request (see page A-8) | Disponível sobre consulta (consulte a página A-8) | Disponible bajo consulta (mire pagina A-8)

LNXT 1306... | Inserts | Pastilhas | Plaquitas

LNXT-MP



LNXT-MP

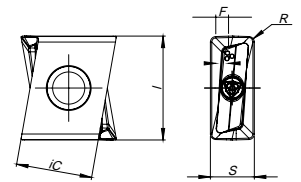

Geometry code	ISO Reference	P			M	K			Dimensions Dimensões Dimensiones (mm)				
		CVD	PVD		PVD	CVD	PVD						
		T9	T1	G6	G6	L6	T1	G6					
⁽¹⁾		PH5740	PHP920	PH7740	PH7740	PH5320	PHP920	PH7740	ic	S	I	R	F
1112242	LNXT 130604 PNER-MP								9,8	6,8	13,0	0,4	0,9
1112243	LNXT 130608 PNER-MP								9,8	6,8	13,0	0,8	0,9

First choice | Primeira opção | 1ª opción

Stock item | Produto de stock | Itens de stock

Available under request (see page A-9) | Disponível sobre consulta (consulte a página A-9) | Disponible bajo consulta (mire pagina A-9)

Insert order code = (1) Geometry Code + (2) Grade Code

A
MILLING
Overview
Face milling
Hifed milling
Shoulder milling
Profile milling
Hardmill
Center & Chamfer
Spot face
Spare Parts
Technical Data
End Mills

TGPLUS 90190

SPARE PARTS | Complementos | Repuestos

Cutter ØDc	Insert Screw	Key (Torx)	Order separately		Order separately	
			Key (Torx - Nm)	Torque Value	Screw	DIN 6368 Wrench
E90190 - 25	P0400900	XT15	DT1530	3,0	-	-
E90190 - 32-40	P0401200	XT15	DT1530	3,0	-	-
W90190 - 25	P0400900	XT15	DT1530	3,0	-	-
W90190 - 32-40	P0401200	XT15	DT1530	3,0	-	-
A90190 - 40-63	P0401200	XT15	DT1530	3,0	-	-
A90190 - 80	P0401200	XT15	DT1530	3,0	J0123510	SD6368-12
A90190 - 100	P0401200	XT15	DT1530	3,0	J0164110	SD6368-16
A90190 -125	P0401200	XT15	DT1530	3,0	J0204610	SD6368-20

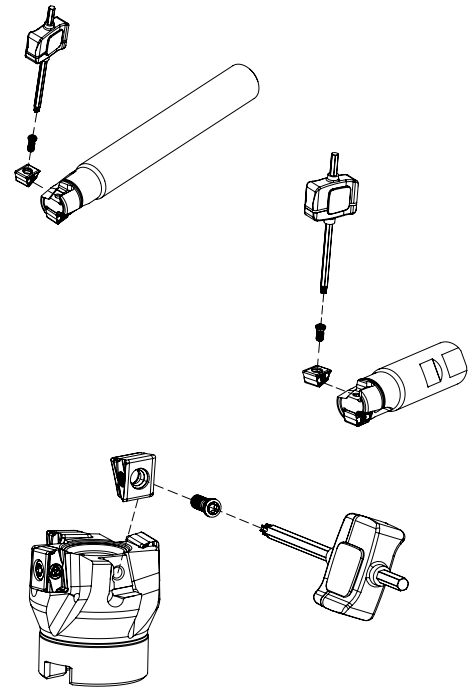

Note: The toolholder is supplied with the XT/PT key. To order the DT key please check the page A-241.
Check the procedures for the clamping screws on the page A-241.

GRADES SELECTION GUIDE | Guia para selección de graus | Tabla para selección de calidades

ISO	PSM	Material	HB (Brinell)	Grades			
				← Wear Resistance		Toughness →	
				PH5320	PHP920	PHS740	PH7740
P	1	Unalloyed Steel	125-220	●	✓	✓	✓
	2	Low-Alloyed Steel	220-280	●	✓	✓	✓
	3	High-Alloyed Steel	280-380	●	✓	✓	✓
M	4	SS - Ferritic / Martensitic	200-330	●			✓
	5	SS - Austenitic	200-330	●			✓
	6	SS - Austenitic-ferritic (Duplex)	230-260	●			✓
K	7	Malleable Cast Iron	130-230	✓	✓		✓
	8	Grey Cast Iron	180-245	✓	✓		✓
	9	Nodular Cast iron	160-250	✓	✓		✓

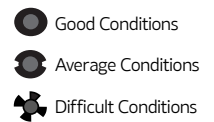

RECOMMENDED CUTTING CONDITIONS | Condições de corte recomendadas | Condiciones de corte recomendables

ISO	PSM	Material	HB (Brinell)	Vc (m/min)				Feed fz (mm/t)
				← Wear Resistance			Toughness →	
				PH5320	PHP920	PHS740	PH7740	
P	1	Unalloyed Steel	125-220	-	180-250	140-220	140-200	0,10-0,35
	2	Low-Alloyed Steel	220-280	-	160-230	120-200	130-180	0,10-0,30
	3	High-Alloyed Steel	280-380	-	140-220	100-190	100-170	0,10-0,20
M	4	SS - Ferritic / Martensitic	200-330	-	-	-	-	0,10-0,30
	5	SS - Austenitic	200-330	-	-	-	-	0,10-0,25
	6	SS - Austenitic-ferritic (Duplex)	230-260	-	-	-	-	0,10-0,20
K	7	Malleable Cast Iron	130-230	150-280	170-300	-	140-220	0,10-0,35
	8	Grey Cast Iron	180-245	160-320	150-250	-	120-210	0,10-0,30
	9	Nodular Cast iron	160-250	100-190	90-210	-	100-190	0,10-0,25

(Note 1) Cutting conditions $a_e/D_c=70\%$.

(Note 2) It's possible to occur vibrations in certain cases. Please reduce depth of cut and / or reduce cutting conditions in following cases:

- When using long shank;
- When using long tool overhang with arbor type;
- When application has poor clamping rigidity or when using a low rigidity machine.



A

MILLING

Overview

Face milling

Hi-feed milling

Shoulder milling

Profile milling

Hardmill

Center & Chamfer

Spotface

Spare Parts

Technical Data

End Mills

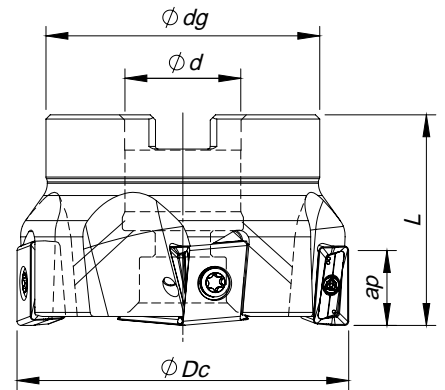

Arbor Mounting
 $K_r=90^\circ$ | $\gamma_p=-5^\circ$

Order code Código	Reference Referência Referencia		Dimensions Dimensões Dimensiones (mm)				Kg	Specifications		Insert Pastilha Inserto	Stock
			ϕDc	ϕd	ϕdg	L		Arbor Type	Ap max (mm)		
181069200	050A90390-05-05-022040	<input checked="" type="checkbox"/>	50	22	42	40	0,315	A	14,0	LNXT 1506...	
181066400	063A90390-05-05-022040	<input checked="" type="checkbox"/>	63	22	52	40	0,524	A	14,0	LNXT 1506...	
181051000	063A90390-08-05-022040	<input checked="" type="checkbox"/>	63	22	52	40	0,550	A	14,0	LNXT 1506...	
181066500	080A90390-07-05-027050	<input checked="" type="checkbox"/>	80	27	60	50	0,936	B	14,0	LNXT 1506...	
181052000	080A90390-10-05-027050	<input checked="" type="checkbox"/>	80	27	60	50	0,939	B	14,0	LNXT 1506...	
181066600	100A90390-08-05-032050	<input checked="" type="checkbox"/>	100	32	80	50	1,586	B	14,0	LNXT 1506...	
181051100	100A90390-12-05-032050	<input checked="" type="checkbox"/>	100	32	80	50	1,690	B	14,0	LNXT 1506...	
181066700	125A90390-09-05-040063	<input checked="" type="checkbox"/>	125	40	90	63	3,001	B	14,0	LNXT 1506...	
181051200	125A90390-15-05-040063	<input checked="" type="checkbox"/>	125	40	90	63	3,113	B	14,0	LNXT 1506...	
181051300	160A90390-10-05-U040063	<input checked="" type="checkbox"/>	160	40	110	63	4,470	C	14,0	LNXT 1506...	
181066800	160A90390-20-05-U040063	<input checked="" type="checkbox"/>	160	40	110	63	4,580	C	14,0	LNXT 1506...	

Stock item | Produto de stock | Itens de stock

Available under request (see page A-8) | Disponível sobre consulta (consulte a página A-8) | Disponible bajo consulta (mire pagina A-8)

SPARE PARTS | Complementos | Repuestos

Cutter ϕDc	Order separately				Order separately	
	Insert Screw	Key (Torx)	Key (Torx - Nm)	Torque Value	Screw	DIN 6368 Wrench
A90390 - 50 - 63	P0401200	XT15	DT1530	3,0	-	-
A90390 - 80	P0401200	XT15	DT1530	3,0	J0123510	SD6368-12
A90390 - 100	P0401200	XT15	DT1530	3,0	J0164110	SD6368-16
A90390 - 125	P0401200	XT15	DT1530	3,0	J0204610	SD6368-20
A90390 - 160	P0401200	XT15	DT1530	3,0	-	-

Note: The toolholder is supplied with the XT/PT key. To order the DT key please check the page A-241.
 Check the procedures for the clamping screws on the page A-241.

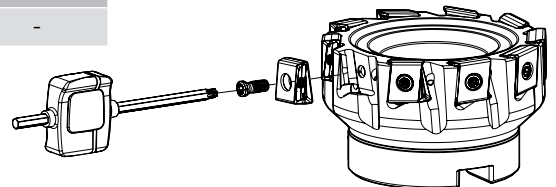

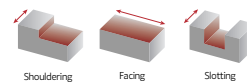

LNXT 1506... | Inserts | Pastilhas | Plaquetas

LNXT-HP

LNXT-MP
(PHP grade)

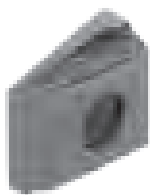

LNXT - MP | HP

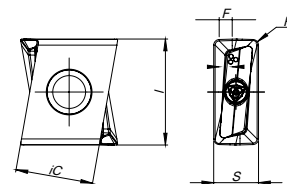

LNXT-W



LNXT-W

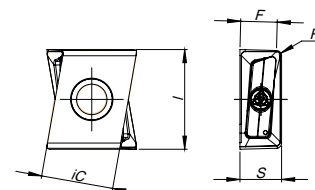

	(2) Grade code	P					K						Dimensions Dimensões Dimensiones (mm)				
		CVD	PVD				CVD		PVD								
(1) Geometry code	ISO Reference	T9	G1	G4	T1	G6	L5	L9	G1	G4	T1	G6	iC	S	I	R	F
1111313	LNXT 150608 PNER-MP	☉	☉	☉	☹	☉	☉	☉	☉	☉	☹	☉	11,0	6,35	15,0	0,8	1,8
1111590	LNXT 150612 PNER-MP			☉	☹	☉	☉	☉		☉	☹	☉	11,0	6,35	15,0	1,2	1,8
1111591	LNXT 150608 PNSR-HP			☹		☉				☹		☉	11,0	6,35	15,0	0,8	1,8
1111524	LNXT 150608 PNER-W		☉				☹		☉				11,0	6,35	15,2	0,8	5,5

☉ First choice | Primeira opção | 1ª opción ☉ Stock item | Produto de stock | Itens de stock ○ Available under request (see page A-9) | Disponível sobre consulta (consulte a página A-9) | Disponible bajo consulta (mire página A-9) Insert order code = (1) Geometry Code + (2) Grade Code

GRADES SELECTION GUIDE | Guia para selecção de graus | Tabla para selección de calidades

ISO	PSM	Material	HB (Brinell)	Grades						
				← Wear Resistance				→ Toughness		
				PH5705	PH7910	PHP920	PH7920	PH5740	PHS740	PH7740
P	1	Unalloyed Steel	125-220	☹	☹	☹	☹	☹	☹	☹
	2	Low-Alloyed Steel	220-280		☹	☹	☹		☹	☹
	3	High-Alloyed Steel	280-380		☹	☹	☹		☹	☹
K	7	Malleable Cast Iron	130-230	☹	☹	☹	☹	☹		☹
	8	Grey Cast Iron	180-245	☹	☹	☹	☹	☹		☹
	9	Nodular Cast iron	160-250	☹	☹	☹	☹	☹		☹

☹ Good Conditions ☹ Average Conditions ☹ Difficult Conditions

TGPLUS 90390

RECOMMENDED CUTTING CONDITIONS | Condições de corte recomendadas | Condiciones de corte recomendables

ISO	PSM	Material	HB (Brinell)	Vc (m/min)						
				← Wear Resistance					Toughness →	
				PH5705	PH7910	PHP920	PH7920	PH5740	PHS740	PH7740
P	1	Unalloyed Steel	125-220	-	180-250	180-250	180-240	-	140-220	140-200
	2	Low-Alloyed Steel	220-280	-	160-230	160-230	160-220	-	120-200	130-180
	3	High-Alloyed Steel	280-380	-	140-220	140-220	140-210	-	100-190	100-170
K	7	Malleable Cast Iron	130-230	160-290	180-300	160-270	160-260	160-260	-	140-220
	8	Grey Cast Iron	180-245	170-320	160-250	140-250	140-240	140-240	-	120-210
	9	Nodular Cast iron	160-250	140-200	150-200	120-210	120-200	120-200	-	100-190

ISO	PSM	Material	HB (Brinell)	Feed fz (mm/t)		
				LNXT 15... MP	LNXT 15... HP	LNXT 15... W
				P	1	Unalloyed Steel
2	Low-Alloyed Steel	220-280	0,10-0,30		0,10-0,30	0,10-0,35
3	High-Alloyed Steel	280-380	0,10-0,25		0,10-0,25	0,10-0,35
K	7	Malleable Cast Iron	130-230	0,10-0,40	0,10-0,40	0,10-0,50
	8	Grey Cast Iron	180-245	0,10-0,35	0,10-0,35	0,10-0,50
	9	Nodular Cast iron	160-250	0,10-0,30	0,10-0,30	0,10-0,50

(Note 1) Cutting conditions $a_e/D_c=70\%$.

(Note 2) It's possible to occur vibrations in certain cases. Please reduce depth of cut and / or reduce cutting conditions in following cases:

- When using long shank;
- When using long tool overhang with arbor type;
- When application has poor clamping rigidity or when using a low rigidity machine.

CHIP-BREAKER SELECTION GUIDE | Guia para aplicações do quebra- aparas | Guía para aplicación del rompevirutas

ISO	PSM	Material	HB (Brinell)	Chip-Breaker Application	
				1st choice	Difficult Operations
P	1	Unalloyed Steel	125-220	LNXT 15... MP	LNXT 15... HP
	2	Low-Alloyed Steel	220-280	LNXT 15... MP	LNXT 15... HP
	3	High-Alloyed Steel	280-380	LNXT 15... MP	LNXT 15... HP
K	7	Malleable Cast Iron	130-230	LNXT 15... MP	LNXT 15... HP
	8	Grey Cast Iron	180-245	LNXT 15... MP	LNXT 15... HP
	9	Nodular Cast iron	160-250	LNXT 15... MP	LNXT 15... HP

WIPER INSERTS

Rec. Cutting Conditions

- F_w at least 40% larger than f_n ($f_n - f_z \times Z$);
- Axial depth of cut is 0,5 - 0,8mm.

Example:

- The width of the parallel land (F) of the insert is 1,8mm
- With a cutter of 10 inserts and using a feed per tooth (f_z) of 0,3mm, the feed per revolution (f_n) will be 3mm, i.e. 40% bigger than the parallel land.
- To obtain a good surface finish, the feed per revolution should be a maximum of 80% of 1,8mm = 1,44mm.
- The wiper insert will have a parallel land (F_w) with a width of approximately 5,5mm.
- Result: Feed per revolution (f_n) could be increased from 0,8mm to 60% of 5,5mm = 3,3mm.

Note: Other limitations, such as machine power, must be taken into consideration.

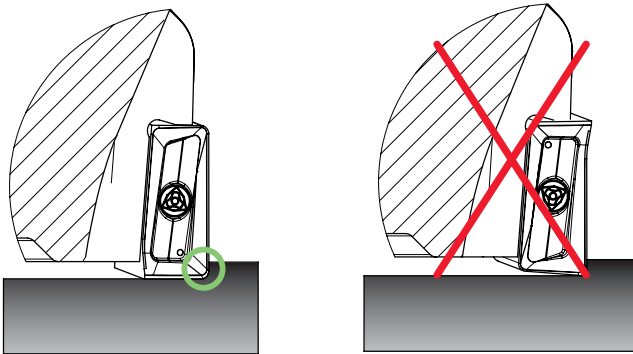

The points on the insert indicates the side that should be parallel to the workspace material.

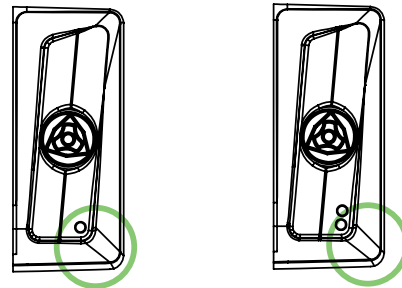

Wiper insert with 2 Right-hand cutting edges.
The side work of the insert it's indicated by points.



PDF

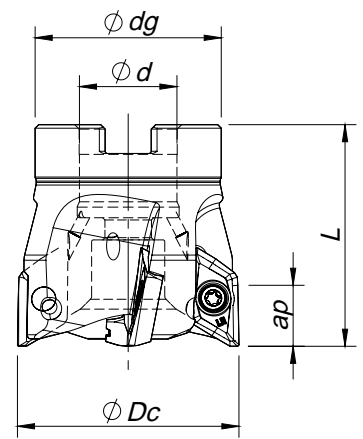

Arbor Mounting

$K_r=90^\circ$ | $\gamma_p=+11^\circ$

Order code Código	Reference Referência Referencia		Dimensions Dimensões Dimensiones (mm)				Kg	Specifications			Insert radius Raio da pastilha Rayo del Inserto	Stock
			ϕDc	ϕd	ϕdg	L		Cutter Type	Max ap (mm)	rpm max		
181094200	040A76090-03-11-016050-A	3	40	16	32	50	0,3	A	14,0	29 000	0,4-3,2	
181083400	050A76090-04-11-022050-A	4	50	22	42	50	0,4	A	14,0	24 000	0,4-3,2	
181085300	063A76090-05-11-022050-A	5	63	22	48	50	0,7	A	14,0	21 000	0,4-3,2	
181094300	080A76090-05-11-027050-A	5	80	27	60	50	1,1	A	14,0	19 000	0,4-3,2	
181094400	100A76090-06-11-032063-A	6	100	32	73	63	2,0	A	14,0	16 000	0,4-3,2	
181094500	040A76090-03-11-016050-B	3	40	16	32	50	0,3	B	14,0	29 000	4,0-5,0	
181094600	050A76090-04-11-022050-B	4	50	22	42	50	0,4	B	14,0	24 000	4,0-5,0	
181094700	063A76090-05-11-022050-B	5	63	22	48	50	0,7	B	14,0	21 000	4,0-5,0	
181094800	080A76090-05-11-027050-B	5	80	27	60	50	1,1	B	14,0	19 000	4,0-5,0	
181094900	100A76090-06-11-032063-B	6	100	32	73	63	2,0	B	14,0	16 000	4,0-5,0	

Stock item | Produto de stock | Itens de stock

Available under request (see page A-8) | Disponível sobre consulta (consulte a página A-8) | Disponible bajo consulta (mire pagina A-8)

Note: Type A cutters can only assemble inserts with a radius between 0,4 and 3,2. Type B cutters can only assemble inserts with a radius between 4,0 and 5,0.

SPARE PARTS | Complementos | Repuestos

Cutter ϕDc	Insert Screw	Key (Torx)	Order separately	
			Key (Torx - Nm)	Torque Value
A76090- 40-80	P0400900	XT15	DT1530	3,0
A76090 - 100	P0400900	PT15	DT1530	3,0
E76090 - 20-25	P0400803	XT15	DT1530	3,0
E76090 - 32-40	P0400900	XT15	DT1530	3,0

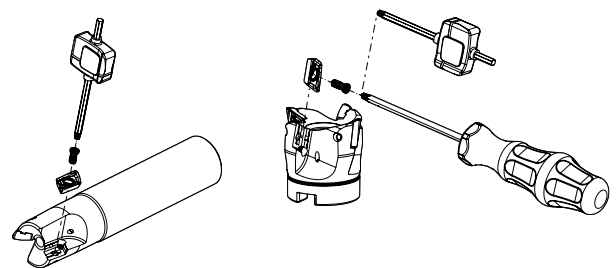

Note: The toolholder is supplied with the XT/PT key. To order the DT key please check the page A-241. Check the procedures for the clamping screws on the page A-241.

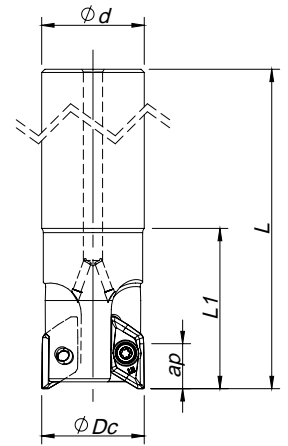
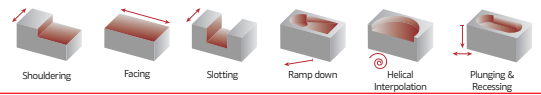

Cylindrical Shank

$K_r=90^\circ$ | $\gamma_p=+6^\circ \sim +11^\circ$

Order code Código	Reference Referência Referencia		Dimensions Dimensões Dimensiones (mm)				Kg	Specifications			Insert radius Raio da pastilha Rayo del Inserto	Stock
			ØDc	Ød	L	L1		Cutter Type	Max ap (mm)	rpm max		
181095000	020E76090-01-06-020150-A		20	20	150	60	0,2	A	15,0	40 000	0,4~3,2	
181095100	025E76090-02-09-025180-A		25	25	180	90	0,4	A	15,0	38 000	0,4~3,2	
181095200	032E76090-02-09-032200-A		32	32	200	120	0,7	A	15,0	33 000	0,4~3,2	
181095300	040E76090-03-11-032250-A		40	32	250	65	1,4	A	15,0	29 000	0,4~3,2	
181095400	020E76090-01-06-020150-B		20	20	150	60	0,2	B	15,0	40 000	4,0~5,0	
181095500	025E76090-02-09-025180-B		25	25	180	90	0,4	B	15,0	38 000	4,0~5,0	
181095600	032E76090-02-09-032200-B		32	32	200	120	0,7	B	15,0	33 000	4,0~5,0	
181095700	040E76090-03-11-032250-B		40	32	250	65	1,4	B	15,0	29 000	4,0~5,0	

Stock item | Produto de stock | Itens de stock

Available under request (see page A-8) | Disponível sobre consulta (consulte a página A-8) | Disponible bajo consulta (mire pagina A-8)

Note: Type A cutters can only assemble inserts with a radius between 0,4 and 3,2. Type B cutters can only assemble inserts with a radius between 4,0 and 5,0.

XDGX 15M5... || Inserts | Pastilhas | Plaquetas

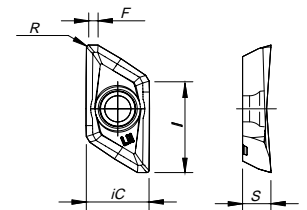

(1) Geometry code	ISO Reference	N UNC 10 PH0910	Dimensions Dimensões Dimensiones (mm)					Cutter Type
			iC	S	I	R	F	
1111624	XDGX 15M504 PDFR-LN		11,20	5,00	16,0	0,40	1,50	A
1111625	XDGX 15M508 PDFR-LN		11,20	5,00	16,0	0,80	1,10	A
1111626	XDGX 15M512 PDFR-LN		11,20	5,00	16,0	1,20	0,70	A
1111627	XDGX 15M516 PDFR-LN		11,20	5,00	16,0	1,60	0,40	A
1111628	XDGX 15M520 PDFR-LN		11,20	5,00	16,0	2,00	0,20	A
1112154	XDGX 15M530 PDFR-LN		11,20	5,00	16,0	3,00	0,60	A
1111629	XDGX 15M532 PDFR-LN		11,20	5,00	16,0	3,20	0,60	A
1111630	XDGX 15M540 PDFR-LN		11,20	5,00	16,0	4,00	0,50	B
1111631	XDGX 15M550 PDFR-LN		11,20	5,00	16,0	5,00	0,40	B

First choice | Primeira opção | 1ª opción

Stock item | Produto de stock | Itens de stock

Available under request (see page A-9) | Disponível sobre consulta (consulte a página A-9) | Disponible bajo consulta (mire pagina A-9)

Insert order code = (1) Geometry Code + (2) Grade Code

ALUPRO 76090

RECOMMENDED CUTTING CONDITIONS | Condições de corte recomendadas | Condiciones de corte recomendables

SHOULDERING							
ISO	PSM	Material	HB (Brinell)	Vc (m/min)	Width of Cut ae (mm)	Depth of Cut ap (mm)	Feed fz(mm/t)
				PH0910			
N	10	Aluminium and Non Ferrous	30-130	350-3000	≤ 25% ØDc	≤5,0	0,35 - 0,40
						5,0 - 10,0	0,30 - 0,35
						10,0 - 15,0	0,25 - 0,30
					< 50% ØDc	≤5,0	0,35 - 0,40
						5,0 - 10,0	0,30 - 0,35
						10,0 - 15,0	0,25 - 0,30
					≤ 75% ØDc	≤5,0	0,30 - 0,35
						5,0 - 10,0	0,25 - 0,30
						10,0 - 15,0	0,20 - 0,25

SLOTING							
ISO	PSM	Material	HB (Brinell)	Vc (m/min)	Width of Cut ae (mm)	Depth of Cut ap (mm)	Feed fz(mm/t)
				PH0910			
N	10	Aluminium and Non Ferrous	30-130	350-3000	100% ØDc	≤5,0	0,25 - 0,35
						5,0 - 10,0	0,20 - 0,30
						10,0 - 15,0	0,15 - 0,25

(Note 1) Cutting conditions $a_e/D_c=70\%$.

(Note 2) It's possible to occur vibrations in certain cases. Please reduce depth of cut and / or reduce cutting conditions in following cases:

- When using long shank;
- When using long tool overhang with arbor type;
- When application has poor clamping rigidity or when using a low rigidity machine.

(Note 3) Use internal coolant supply

OPERATIONAL GUIDE | Guia operacional | Guía operativa

- The maximum allowable revolutions are shown in Table 1. Ensure that the cutter operates under the maximum allowable revolutions. The maximum allowable revolutions for safety purposes are determined in accordance with ISO 15641 (Milling Cutters for high speed machining-Safety requirements).

Table 1 - Maximum allowable revolutions:

ØDc	Ø20	Ø25	Ø32	Ø40	Ø50	Ø63	Ø80	Ø100
RPM (min ⁻¹)	40000	38000	33000	29000	24000	21000	19000	16000

- Even when operating under the maximum allowable spindle speed, if the spindle speed is equal or higher than the values shown in Table 2., it is recommended that the balance quality (with the arbor or chuck) according ISO 1940.

Table 2 - Maximum revolutions when balancing with the arbor or chuck has not been achieved:

ØDc	Ø20	Ø25	Ø32	Ø40	Ø50	Ø63	Ø80	Ø100
RPM (min ⁻¹)	15000	12000	9500	8500	7600	6800	6000	5400

- When setting the spindle speed, take into consideration the maximum allowable revolutions of arbor or chuck.
- Use the specified set bolt when using the arbor type with internal coolant supply.

RAMPING AND HELICAL INTERPOLATION

Descida em rampa e interpolação helicoidal | Bajada en rampa e interpolación circular

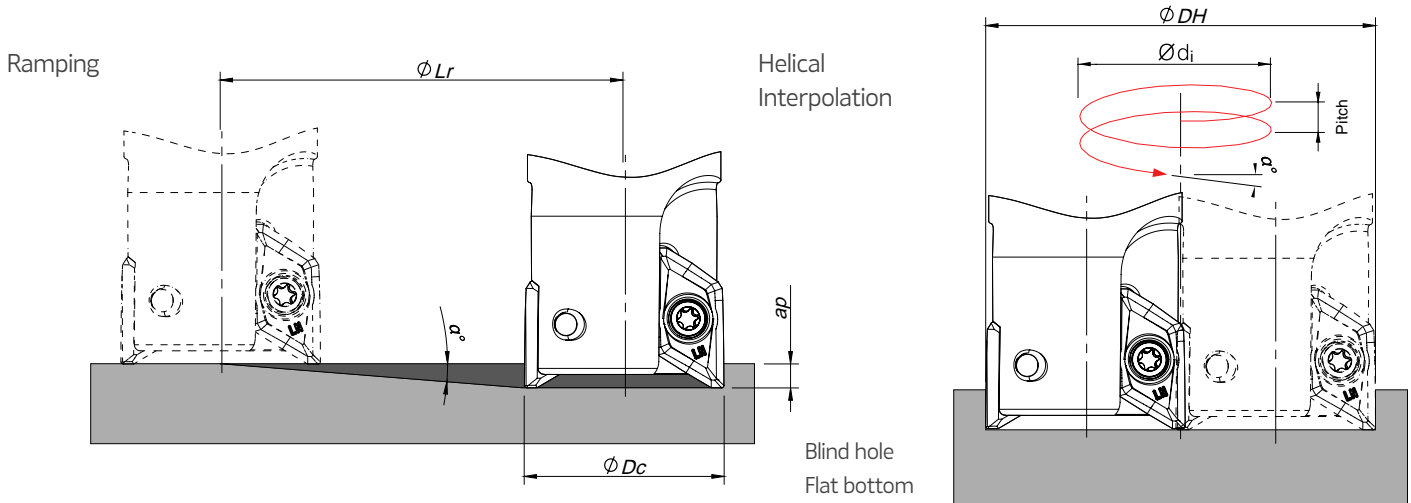

$$\phi_{di} = \phi_{DH} - \phi_{Dc}$$

Cutter Type	ϕ_{Dc}	Ramping			Helical Interpolation		
		Max Ramp a°	Max ap	Min L_r	Diameter for Blind Hole, Flat Bottom Face (1)		Max Pitch/Rev.
					ϕ_{DHmin}	ϕ_{DHmax}	
A	20	23	15,0	35,3	36,2 -	- 38,4	21,6 24,5
	25	21	15,0	39,1	46,2 -	- 48,4	25,6 28,2
	32	15	15,0	56,0	60,2 -	- 62,4	23,7 25,6
	40	10	15,0	85,1	76,2 -	- 78,4	20,0 21,3
	50	8	15,0	106,7	96,2 -	- 98,4	20,4 21,4
	63	6	15,0	142,7	122,2 -	- 124,4	19,5 20,3
	80	4	15,0	214,5	156,2 -	- 158,4	16,7 17,2
	100	2,5	15,0	343,6	196,2 -	- 198,4	13,2 13,5
B	20	20	13,5	37,1	36,2 -	- 38,4	18,5 21,0
	25	18,5	13,5	40,3	46,2 -	- 48,4	22,3 24,6
	32	13,5	13,5	56,2	60,2 -	- 62,4	21,3 22,9
	40	8,5	13,5	90,3	76,2 -	- 78,4	17,0 18,0
	50	7	13,5	109,9	96,2 -	- 98,4	17,8 18,7
	63	5,5	13,5	140,2	122,2 -	- 124,4	17,9 18,6
	80	3,5	13,5	220,7	156,2 -	- 158,4	14,6 15,1
	100	2,5	13,5	309,2	196,2 -	- 198,4	13,2 13,5

(1) using insert radius 0,8 mm

Note: During helical interpolation do not exceed maximum pitch.
When using different insert radius to calculate the ϕ_{DHmin} and ϕ_{DHmax} use the equation below:
- Minimum Diameter: $\phi_{DHmin} = 2 \times (\phi_{Dc} - (R \text{ corner radius} + F \text{ width of edge wiper}))$
- Maximum Diameter: $\phi_{DHmax} = 2 \times (\phi_{Dc} - R \text{ corner radius})$



PDF

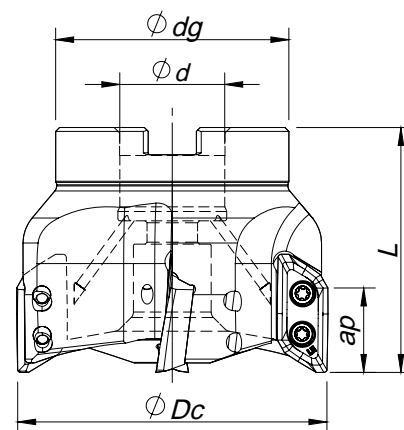

Arbor Mounting

$K_r=90^\circ$ | $\gamma_p=+7^\circ$

Order code Código	Reference Referência Referencia		Dimensions Dimensões Dimensiones (mm)				Kg	Specifications			Insert radius Raio da pastilha Rayo del Inserto	Stock
			ϕDc	ϕd	ϕdg	L		Cutter Type	Max ap (mm)	rpm max		
181093000	050A77090-03-07-022050-A	3	50	22	42	50	0,4	A	21,5	30 000	0,8-3,2	
181093100	063A77090-03-07-022050-A	3	63	22	42	50	0,5	A	21,5	25 000	0,8-3,2	
181071600	080A77090-04-07-027063-A	4	80	27	60	63	1,2	A	21,5	23 000	0,8-3,2	
181093200	100A77090-05-07-032063-A	5	100	32	70	63	1,8	A	21,5	19 000	0,8-3,2	
181093300	125A77090-06-07-040063-A	6	125	40	100	63	2,7	A	21,5	16 000	0,8-3,2	
181093400	050A77090-03-07-022050-B	3	50	22	42	50	0,4	B	21,0	30 000	4,0-5,0	
181093500	063A77090-03-07-022050-B	3	63	22	42	50	0,5	B	21,0	25 000	4,0-5,0	
181093600	080A77090-04-07-027063-B	4	80	27	60	63	1,2	B	21,0	23 000	4,0-5,0	
181093700	100A77090-05-07-032063-B	5	100	32	70	63	1,8	B	21,0	19 000	4,0-5,0	
181093800	125A77090-06-07-040063-B	6	125	40	100	63	2,7	B	21,0	16 000	4,0-5,0	

Stock item | Produto de stock | Itens de stock

Available under request (see page A-8) | Disponível sobre consulta (consulte a página A-8) | Disponible bajo consulta (mire pagina A-8)

Note: Type A cutters can only assemble inserts with a radius between 0,4 and 3,2. Type B cutters can only assemble inserts with a radius between 4,0 and 5,0.

SPARE PARTS | Complementos | Repuestos

Cutter ϕDc	Order separately				Order separately	
	Insert Screw	Key (Torx)	Key (Torx - Nm)	Torque Value	Screw	DIN 6368 Wrench
A77090 - 50-80	P0401200	XT15	DT1530	3,0	-	-
A77090 - 100	P0401200	PT15	DT1530	3,0	J0164110	SD6368-16
A77090 - 125	P0401200	PT15	DT1530	3,0	J0204610	SD6368-20
E77090 - 32-40	P0401200	XT15	DT1530	3,0	-	-

Note: The toolholder is supplied with the XT/PT key. To order the DT key please check the page A-241.
Check the procedures for the clamping screws on the page A-241.

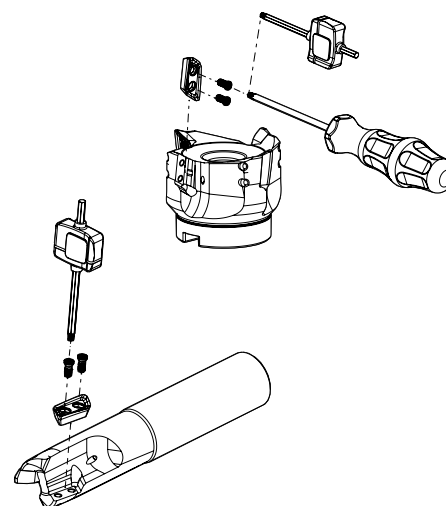

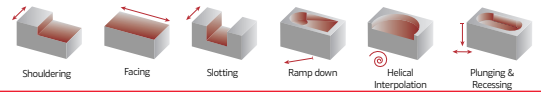

Cylindrical Shank
 $K_r=90^\circ$ | $\gamma_p=+6^\circ$

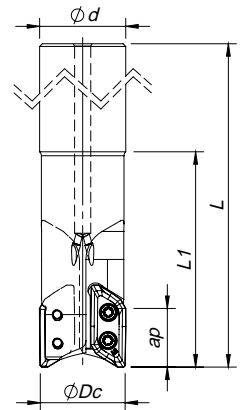

Order code Código	Reference Referência Referencia		Dimensions Dimensões Dimensiones (mm)				Kg	Specifications			Insert radius Raio da pastilha Rayo del Inserto	Stock
			ØDc	Ød	L	L1		Cutter Type	Max ap (mm)	rpm max		
181069800	032E77090-02-06-032170-A	2	32	32	170	80	0,8	A	21.5	41 000	0,8~3,2	⊗
181093900	040E77090-02-06-040170-A	2	40	40	170	80	0,9	A	21.5	36 000	0,8~3,2	⊗
181094000	032E77090-02-06-032170-B	2	32	32	170	80	0,8	B	21.0	41 000	4,0~5,0	○
181094100	040E77090-02-06-040170-B	2	40	40	170	80	0,9	B	21.0	36 000	4,0~5,0	⊗

⊗ Stock item | Produto de stock | Itens de stock

○ Available under request (see page A-8) | Disponível sobre consulta (consulte a página A-8) | Disponible bajo consulta (mire pagina A-8)

Note: Type A cutters can only assemble inserts with a radius between 0,4 and 3,2. Type B cutters can only assemble inserts with a radius between 4,0 and 5,0.

XDGX 22M7... || Inserts | Pastilhas | Plaquitás

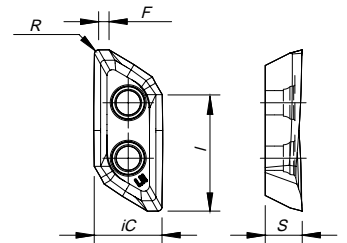

(1) Geometry code	ISO Reference	N		Dimensions Dimensões Dimensiones (mm)					Cutter Type
		UNC	10	iC	S	I	R	F	
1111618	XDGX 22M708 PDFR-LN	⊗	⊗	13,00	7,00	22,0	0,80	2,00	A
1111619	XDGX 22M716 PDFR-LN	⊗	⊗	13,00	7,00	22,0	1,60	1,20	A
1111620	XDGX 22M720 PDFR-LN	⊗	⊗	13,00	7,00	22,0	2,00	0,80	A
1111621	XDGX 22M732 PDFR-LN	⊗	⊗	13,00	7,00	22,0	3,20	0,60	A
1111622	XDGX 22M740 PDFR-LN	⊗	⊗	13,00	7,00	22,0	4,00	0,90	B
1111623	XDGX 22M750 PDFR-LN	⊗	⊗	13,00	7,00	22,0	5,00	0,40	B

⊗ First choice | Primeira opção | 1ª opción

⊗ Stock item | Produto de stock | Itens de stock

○ Available under request (see page A-9) | Disponível sobre consulta (consulte a página A-9) | Disponible bajo consulta (mire pagina A-9)

Insert order code = (1) Geometry Code + (2) Grade Code

ALUPRO 77090

RECOMMENDED CUTTING CONDITIONS | Condições de corte recomendadas | Condiciones de corte recomendables

SHOULDERING							
ISO	PSM	Material	HB (Brinell)	Vc (m/min)	Width of Cut ae (mm)	Depth of Cut ap (mm)	Feed fz(mm/t)
				PH0910			
N	10	Aluminium and Non Ferrous	30-130	350-3000	≤ 25% ØDc	≤5,0	0,35 - 0,40
						5,0 - 10,0	0,30 - 0,35
						10,0 - 15,0	0,25 - 0,30
						15,0 - 20,0	0,20 - 0,25
					< 50% ØDc	≤5,0	0,35 - 0,40
						5,0 - 10,0	0,30 - 0,35
						10,0 - 15,0	0,25 - 0,30
						15,0 - 20,0	0,20 - 0,25
					≤ 75% ØDc	≤5,0	0,30 - 0,35
						5,0 - 10,0	0,25 - 0,30
						10,0 - 15,0	0,20 - 0,25
						15,0 - 20,0	0,15 - 0,20

SLOTING							
ISO	PSM	Material	HB (Brinell)	Vc (m/min)	Width of Cut ae (mm)	Depth of Cut ap (mm)	Feed fz(mm/t)
				PH0910			
N	10	Aluminium and Non Ferrous	30-130	350-3000	100% ØDc	≤5,0	0,25 - 0,35
						5,0 - 10,0	0,20 - 0,30
						10,0 - 15,0	0,15 - 0,25
						15,0 - 20,0	0,10 - 0,20

(Note 1) Cutting conditions $a_e/D_c=70\%$.

(Note 2) It's possible to occur vibrations in certain cases. Please reduce depth of cut and / or reduce cutting conditions in following cases:

- When using long shank;
- When using long tool overhang with arbor type;
- When application has poor clamping rigidity or when using a low rigidity machine.

(Note 3) Use internal coolant supply.

OPERATIONAL GUIDE | Guia operacional | Guía operativa

- Only use the inserts and parts provided by Palbit with this tool. Use of the correct insert clamp screws is especially important to ensure overall tool safety. Do not use damaged or worn clamp screws.

- When tightening the clamp screws, follow the order in Figure 1. The recommended torque value is 3.5Nm.

- The maximum allowable revolutions are shown in Table 1. Ensure that the cutter operates under the maximum allowable revolutions.

The maximum allowable revolutions for safety purposes are determined in accordance with ISO 15641 (Milling Cutters for high speed machining-Safety requirements).

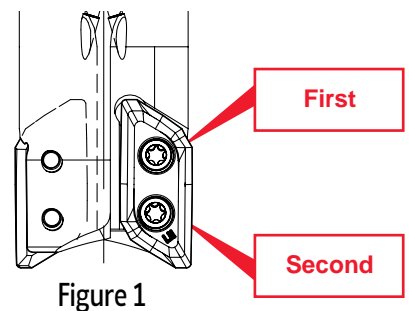

Table 1 - Maximum allowable revolutions:

ØDc	Ø32	Ø40	Ø50	Ø63	Ø80	Ø100	Ø125
RPM (min ⁻¹)	41000	36000	30000	25000	23000	19000	16000

- Even when operating under the maximum allowable spindle speed, if the spindle speed is equal or higher than the values shown in Table 2., it is recommended that the balance quality (with the arbor or chuck) according ISO 1940.

Table 2 - Maximum revolutions when balancing with the arbor or chuck has not been achieved:

ØDc	Ø32	Ø40	Ø50	Ø63	Ø80	Ø100	Ø125
RPM (min ⁻¹)	9500	7600	6000	4800	3800	3000	2400

- When setting the spindle speed, take into consideration the maximum allowable revolutions of arbor or chuck.
- Use the specified set bolt when using the arbor type with internal coolant supply.

RAMPING AND HELICAL INTERPOLATION

Descida em rampa e interpolação helicoidal | Bajada en rampa e interpolación circular

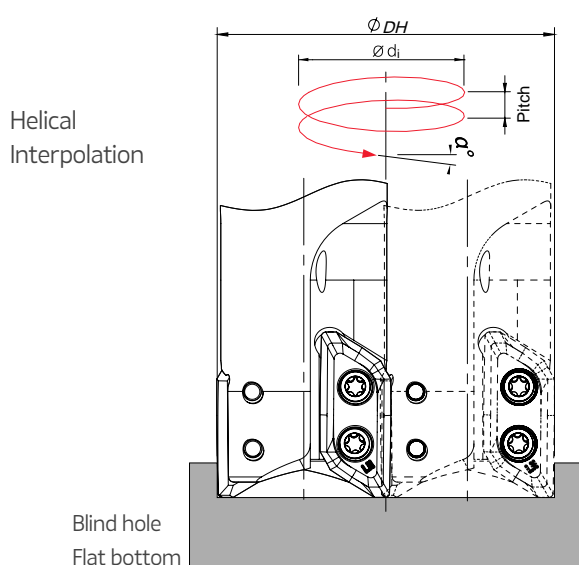
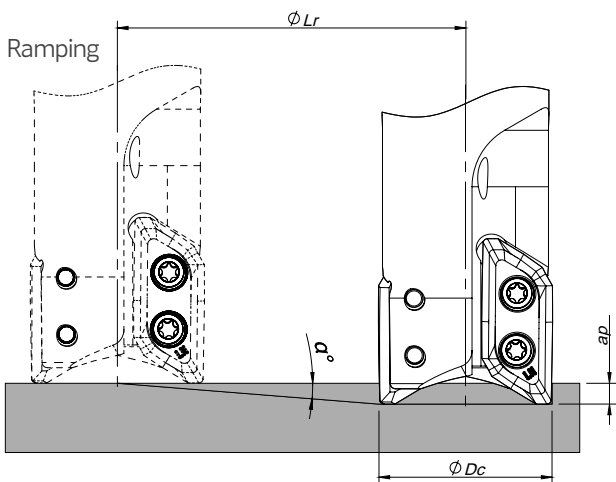

$$\text{Ødi} = \text{ØDH} - \text{ØDc}$$

Cutter Type	ØDc	Ramping		Helical Interpolation			
		Max Ramp α°	Max ap	Min Lr	Diameter for Blind Hole, Flat Bottom Face (1)		Max Pitch/Rev.
					ØDHmin	ØDHmax	
A	32	19	21,5	62,4	60,0 - 62,4	30,3 - 32,9	
	40	13	21,5	93,1	76,0 - 78,4	26,1 - 27,8	
	50	9	21,5	135,7	96,0 - 98,4	22,9 - 24,1	
	63	7	21,5	175,1	122,0 - 124,4	22,7 - 23,7	
	80	5	21,5	245,7	156,0 - 158,4	20,9 - 21,5	
	100	4	21,5	307,5	196,0 - 198,4	21,1 - 21,6	
	125	3	21,5	410,2	246,0 - 248,4	19,9 - 20,3	
B	32	18	21,0	64,6	60,0 - 62,4	28,6 - 31,0	
	40	11	21,0	108,0	76,0 - 78,4	22,0 - 23,4	
	50	8	21,0	149,4	96,0 - 98,4	20,3 - 21,4	
	63	6	21,0	199,8	122,0 - 124,4	19,5 - 20,3	
	80	4	21,0	300,3	156,0 - 158,4	16,7 - 17,2	
	100	3	21,0	400,7	196,0 - 198,4	15,8 - 16,2	
	125	2	21,0	601,4	246,0 - 248,4	13,3 - 13,5	

(1) using insert radius 0,8 mm

Note: During helical interpolation do not exceed maximum pitch.

When using different insert radius to calculate the ØDHmin and ØDHmax use the equation below:

- Minimum Diameter: $\text{ØDHmin} = 2 \times (\text{ØDc} - (\text{R corner radius} + \text{F width of edge wiper}))$

- Maximum Diameter: $\text{ØDHmax} = 2 \times (\text{ØDc} - \text{R corner radius})$



PDF

ALUPRO 08390

A

MILLING

Overview

Face milling

Hi-feed milling

Shoulder milling

Profile milling

Hardmill

Center & Chamfer

Spot face

Spare Parts

Technical Data

End Mills



Threaded Coupling

$K_r=90^\circ$ | $\gamma_p=0^\circ$

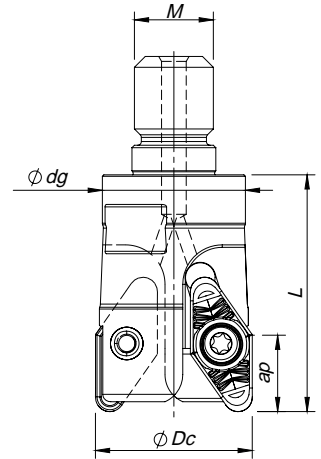

Order code Código	Reference Referência Referencia		Dimensions Dimensões Dimensiones (mm)				Kg	Specifications	Insert Pastilha Inserto	Stock
			ϕDc	$\phi d/M$	ϕdg	L		A_p max (mm)		
181019900	032R08390-02-M16048	2	32	M16	29	48	0,19	15,00	VCGX 22...	

Stock item | Produto de stock | Itens de stock

Available under request (see page A-8) | Disponível sobre consulta (consulte a página A-8) | Disponible bajo consulta (mire página A-8)

VCGX 220530 | Inserts | Pastilhas | Plaquetas

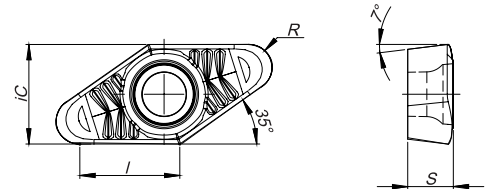

(1) Geometry code	ISO Reference	N		Dimensions Dimensões Dimensiones (mm)			
		UNC	10	iC	S	L	R
1121907	VCGX 220530 LN			12,70	5,60	12,7	3,00

First choice | Primeira opção | 1ª opción

Stock item | Produto de stock | Itens de stock

Available under request (see page A-8) | Disponível sobre consulta (consulte a página A-8) | Disponible bajo consulta (mire página A-8)

Insert order code = (1) Geometry Code + (2) Grade Code

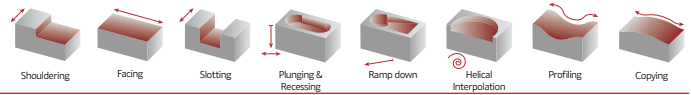

SPARE PARTS | Complementos | Repuestos

Cutter ØDc	Insert Screw	Key (Torx)	Order separately	
			Key (Torx - Nm)	Torque Value
R08390 - 32	P0451001	XT20	DT2050	5,00

Note: The toolholder is supplied with the XT/PT key. To order the DT key please check the page A-241.
Check the procedures for the clamping screws on the page A-241.

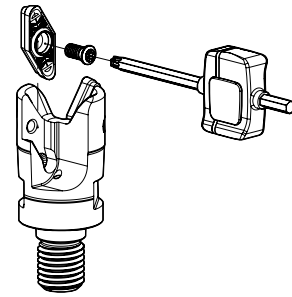

RECOMMENDED CUTTING CONDITIONS | Condições de corte recomendadas | Condiciones de corte recomendables

ISO	PSM	Material	HB (Brinell)	Vc (m/min)	Feed fz (mm/t)
				PH0910	VCGX 22...
N	10	Aluminium and Non Ferrous	30-130	350-1400	0,20-0,50

ØDc	Ø32
RPM (min ⁻¹)	9500

(Note 1) Cutting conditions $a_e/D_c=70\%$.

(Note 2) It's possible to occur vibrations in certain cases. Please reduce depth of cut and / or reduce cutting conditions in following cases:

- When using long shank;
- When using long tool overhang with arbor type;
- When application has poor clamping rigidity or when using a low rigidity machine.

(Note 3) Use internal coolant supply

RAMPING AND HELICAL INTERPOLATION

Descida em rampa e interpolação helicoidal | Bajada en rampa e interpolación circular

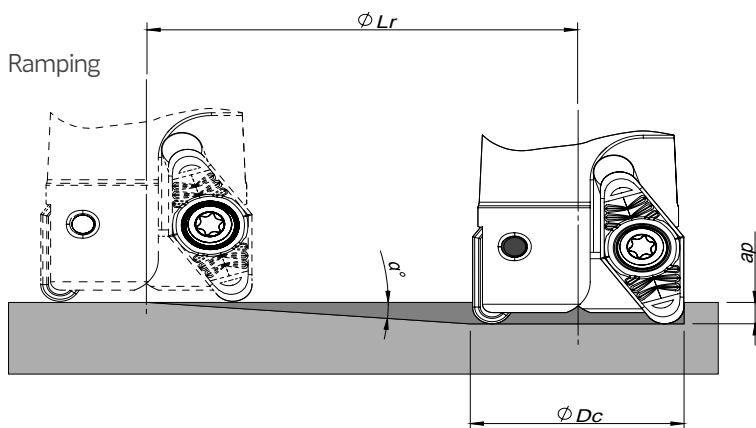

Helical Interpolation

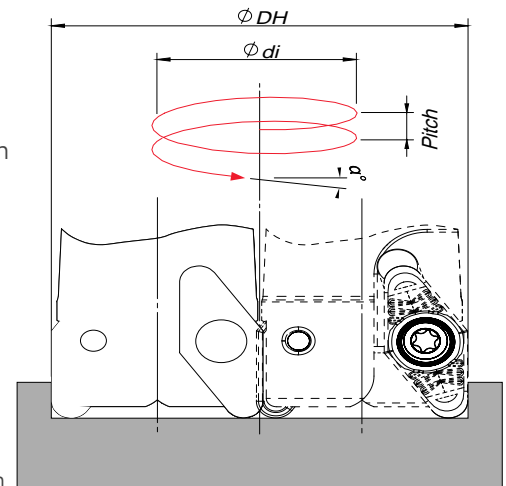

Blind hole
Flat bottom

$$\text{Ødi} = \text{ØDH} - \text{ØDc}$$

ØDc	Ramping			Helical Interpolation		
	Max Ramp α°	Max a_p	Min Lr	ØDHmin	ØDHmax	Max Pitch/Rev.
32	6,8	15,0	25,4	53,0	-	7,0
				-	62,0	11,0

Note: During helical interpolation do not exceed max Pitch.

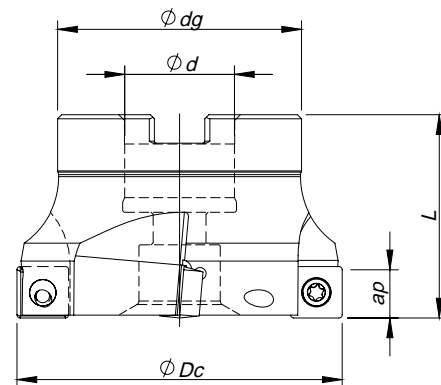
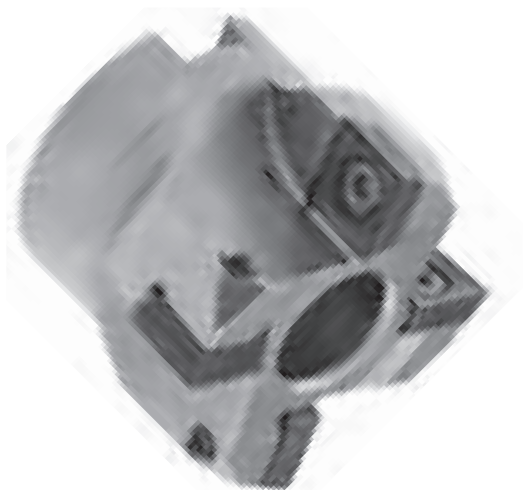

Arbor Mounting

$K_r=90^\circ$ | $\gamma_p=+6^\circ$

Order code Código	Reference Referência Referencia		Dimensions Dimensões Dimensiones (mm)				Kg	Specifications		Insert Pastilha Inserto	Stock
			ϕDc	ϕd	ϕdg	L		Arbor Type	Ap max (mm)		
181167700	040A06290-03-06-016040		40	16	39	40	0,2	A	11	SP...1204	
181167800	050A06290-04-06-022040		50	22	49	40	0,35	A	11	SP...1204	
181167900	063A06290-05-06-027050		63	27	60	50	0,7	A	11	SP...1204	
181168000	080A06290-06-06-027050		80	27	60	50	1,15	A	11	SP...1204	
181168100	100A06290-08-06-032050		100	32	80	50	1,75	A	11	SP...1204	
181168200	125A06290-08-06-040063		125	40	96	63	3,05	B	11	SP...1204	
181065600	160A06290-10-06-U040063		160	40	100	63	4,2	C	11	SP...1204	

Stock item | Produto de stock | Itens de stock

Available under request (see page A-8) | Disponível sobre consulta (consulte a página A-8) | Disponible bajo consulta (mire pagina A-8)

SP... 1204... || Inserts | Pastilhas | Plaquetas

SPMX - MP

NEW

SPGX-MS

NEW

SPGX-MP | SPMW-MS

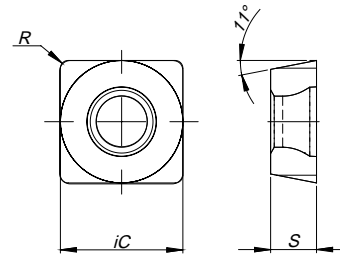

Geometry code	ISO Reference	P	M	K	S	Dimensions Dimensões Dimensiones (mm)		
		PVD	PVD	PVD	PVD	iC	S	R
		(2) Grade code	T1	X9	T1			
(1)		PHH920	PHH930	PHP920	PHH930			
1113002	SPGX 120408 PDSR-MP					12,73	4,8	0,8
1113003	SPGX 120408 PDSR-MS					12,73	4,8	0,8
1112916	SPMX 120408 PDSR-MP					12,73	4,8	0,8
1112999	SPMX 120408 PDSR-MS					12,73	4,8	0,8

First choice | Primeira opção | 1ª opción

Stock item | Produto de stock | Itens de stock

Available under request (see page A-9) | Disponível sobre consulta (consulte a página A-9) | Disponible bajo consulta (mire pagina A-9)

Insert order code = (1) Geometry Code + (2) Grade Code

SPMT 120408-MP	SPMW 120408
Page A - 50	

Note: It is possible to use other inserts - Page A - 50

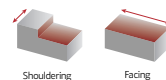

SPARE PARTS | Complementos | Repuestos

Cutter ØDc	Insert Screw	Key (Torx)	Order separately	
			Key (Torx - Nm)	Torque Value
A06290 – 40 - 160	P0501100	PT20	DT2050	5,00

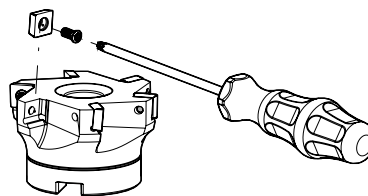

Note: The toolholder is supplied with the XT/PT key. To order the DT key please check the page A-241.
Check the procedures for the clamping screws on the page A-241.

RECOMMENDED CUTTING CONDITIONS | Condições de corte recomendadas | Condiciones de corte recomendables

ISO	PSM	Material	HB (Brinell)	Vc (m/min)		Feed fz (mm/t)	
				← Wear Resistance	Toughness →	SPG(M)X... MP	SPM(M)X ...MS
				PHP920	PHH930		
P	1	Unalloyed Steel	125-220	180-250	-	0,08-0,20	-
	2	Low-Alloyed Steel	220-280	170-210	-	0,08-0,20	-
	3	High-Alloyed Steel	280-380	160-200	-	0,08-0,20	-
M	4	SS - Ferritic / Martensitic	200-330	-	120-180	-	0,08-0,20
	5	SS - Austenitic	200-330	-	100-160	-	0,08-0,20
	6	SS - Austenitic-ferritic (Duplex)	230-260	-	70-140	-	0,08-0,20
K	7	Malleable Cast Iron	130-230	170-300	-	0,10-0,30	-
	8	Grey Cast Iron	180-245	150-250	-	0,10-0,30	-
	9	Nodular Cast iron	160-250	90-210	-	0,10-0,30	-
S	11	Heat Resistant Super Alloys	200-320	-	30-75	-	0,08-0,15

(Note 1) Cutting conditions ae/DC=70%

(Note 2) Cutting conditions should be adjusted according to the machine and work rigidity.

(Note 3) If chattering occurs, reduce ap and Vc by 30% and keep the same fz per tooth.

CHIP-BREAKER SELECTION GUIDE | Guia para aplicações do quebra- aparas | Guía para aplicación del rompevirutas

ISO	PSM	Material	HB (Brinell)	Chip-Breaker Application	
				1st choice	Difficult Operations
P	1	Unalloyed Steel	125-220	... MS	... MP
	2	Low-Alloyed Steel	220-280	... MS	... MP
	3	High-Alloyed Steel	280-380	... MP	... MP
M	4	SS - Ferritic / Martensitic	200-330	... MS	... MP
	5	SS - Austenitic	200-330	... MS	... MS
	6	SS - Austenitic-ferritic (Duplex)	230-260	... MS	... MS
K	7	Malleable Cast Iron	130-230	... MP	... MP
	8	Grey Cast Iron	180-245	... MP	... MP
	9	Nodular Cast iron	160-250	... MP	... MP
S	11	Heat Resistant Super Alloys	200-320	... MS	... MS

LINEPRO 17090

A

MILLING

Overview

Face milling

Hi-feed milling

Shoulder milling

Profile milling

Hardmill

Center & Chamfer

Spot face

Spare Parts

Technical Data

End Mills

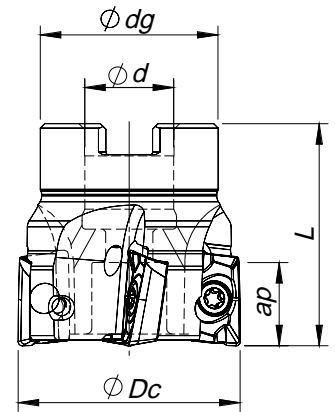
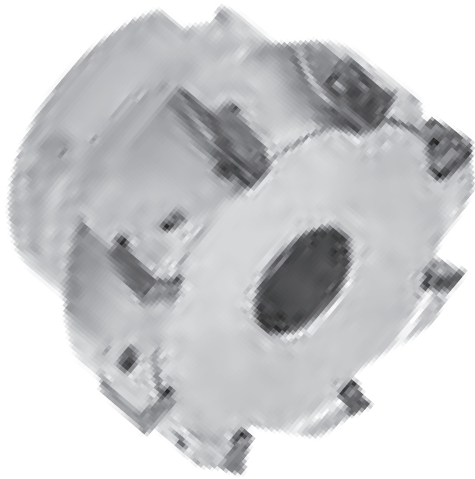

Arbor Mounting

$K_r=90^\circ$ | $\gamma_p=+9^\circ$

Order code Código	Reference Referência Referencia		Dimensions Dimensões Dimensiones (mm)				Kg	Specifications		Insert Pastilha Inserto	Stock
			ϕDc	ϕd	ϕdg	L		Arbor Type	Ap max (mm)		
181010200	040A17090-06-09-022040	6	40	22	39	40	0,210	A	9,0	AP... 1003...	
181010300	050A17090-07-09-022040	7	50	22	40	40	0,320	A	9,0	AP... 1003...	
181014300	063A17090-08-09-022040	8	63	22	48	40	0,560	A	9,0	AP... 1003...	

Stock item | Produto de stock | Itens de stock

Available under request (see page A-8) | Disponível sobre consulta (consulte a página A-8) | Disponible bajo consulta (mire pagina A-8)

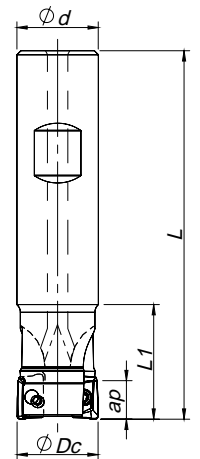

Weldon Shank

$K_r=90^\circ$ | $\gamma_p=+7^\circ \sim +9^\circ$

Order code Código	Reference Referência Referencia		Dimensions Dimensões Dimensiones (mm)				Kg	Specifications		Insert Pastilha Inserto	Stock
			ϕDc	ϕd	L	L1		Ap max (mm)			
181041300	016W17090-02-07-016085	2	16	16	85	26	0,110	9,0	AP... 1003...		
181031700	016W17090-02-07-016150	2	16	16	150	26	0,210	9,0	AP... 1003...		
181041400	020W17090-03-09-020090	3	20	20	90	28	0,190	9,0	AP... 1003...		
181041600	020W17090-03-09-020150	3	20	20	150	28	0,320	9,0	AP... 1003...		
181041700	025W17090-04-09-020150	4	25	20	150	26	0,340	9,0	AP... 1003...		
181041500	025W17090-04-09-025095	4	25	25	95	30	0,310	9,0	AP... 1003...		

Stock item | Produto de stock | Itens de stock

Available under request (see page A-8) | Disponível sobre consulta (consulte a página A-8) | Disponible bajo consulta (mire pagina A-8)

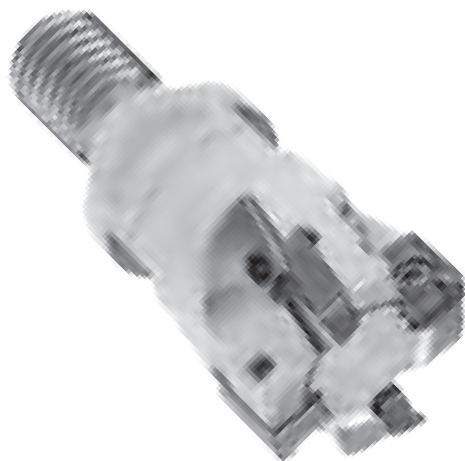
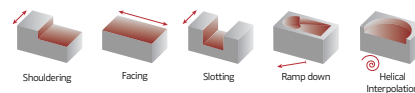

Threaded Coupling

$$K_r=90^\circ \mid \gamma_p=+7^\circ \sim +9^\circ$$

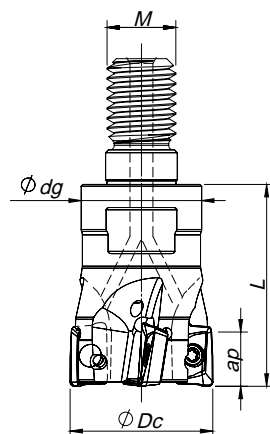

Order code Código	Reference Referência Referencia		Dimensions Dimensões Dimensiones (mm)				Kg	Specifications		Insert Pastilha Inserto	Stock
			ϕDc	ϕM	ϕdg	L		A_p max (mm)			
181015100	016R17090-02-07-M08025		16	M8	13	25	0,030	9,0	AP... 1003...		
181015200	020R17090-03-09-M10030		20	M10	18	30	0,058	9,0	AP... 1003...		
181015300	025R17090-04-09-M12035		25	M12	21	35	0,110	9,0	AP... 1003...		

Stock item | Produto de stock | Itens de stock

Available under request (see page A-8) | Disponível sobre consulta (consulte a página A-8) | Disponible bajo consulta (mire pagina A-8)

AP... 1003... || Inserts | Pastilhas | Plaquetas

APET - LN



APKT - X



APKT - X1



APET-LN | APKT-X | APKT-X1

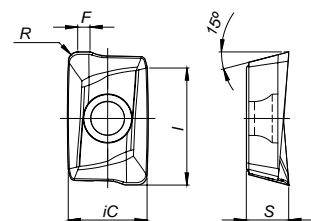

Geometry code	ISO Reference	P		M	K		N	Dimensions Dimensões Dimensiones (mm)				
		PVD		PVD	PVD		UNC	iC	S	I	R	F
		68	66	66	68	66	10					
⁽¹⁾		PH6920	PH6930	PH6930	PH6920	PH6930	PH0910					
1112043	APET 100305 PDFR-LN							6,70	3,50	10,00	0,50	1,20
1112168	APKT 100305 PDER-X1							6,70	3,50	10,00	0,50	1,20
1112167	APKT 100305 PDSR-X1							6,70	3,50	10,00	0,50	1,20
1111071	APKT 100308 PDER-X							6,70	3,50	10,00	0,80	0,90
1111044	APKT 100308 PDSR-X							6,70	3,50	10,00	0,80	0,90
1111042	APKT 100308 PDTR-X							6,70	3,50	10,00	0,80	0,90
1111072	APKT 100312 PDER-X							6,70	3,50	10,00	1,20	-
1110987	APKT 100312 PDSR-X							6,70	3,50	10,00	1,20	-
1111045	APKT 100312 PDTR-X							6,70	3,50	10,00	1,20	-

First choice | Primeira opção | 1ª opción

Stock item | Produto de stock | Itens de stock

Available under request (see page A-9) | Disponível sobre consulta (consulte a página A-9) | Disponible bajo consulta (mire pagina A-9)

Insert order code = (1) Geometry Code + (2) Grade Code

LINEPRO 17090

SPARE PARTS | Complementos | Repuestos

Cutter ØDc	Insert Screw	Key (Torx)	Order separately	
			Key (Torx - Nm)	Torque Value
W17090 - 16-25	P0250503	XT08	DT0812	1,2
R17090 - 16-25	P0250503	XT08	DT0812	1,2
A17090 - 40-63	P0250503	XT08	DT0812	1,2

Note: The toolholder is supplied with the XT/PT key. To order the DT key please check the page A-241. Check the procedures for the clamping screws on the page A-241.

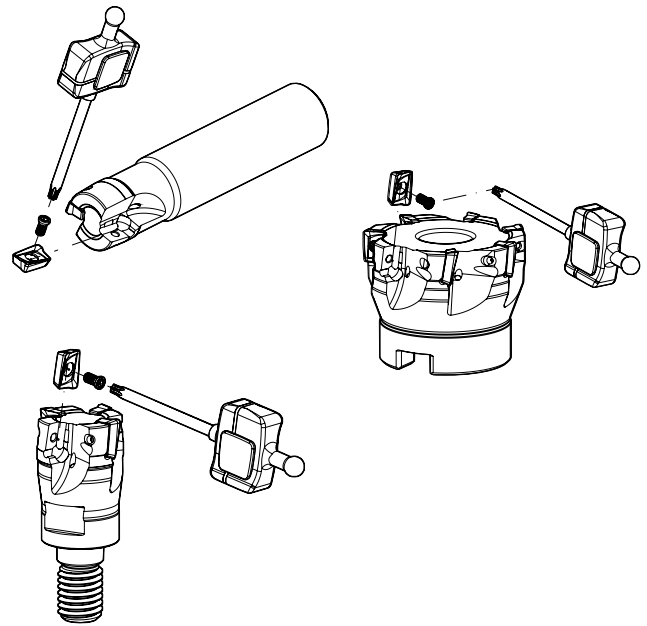

GRADES SELECTION GUIDE | Guia para selección de graus | Tabla para selección de calidades

ISO	PSM	Material	HB (Brinell)	Grades		
				← Wear Resistance		Toughness →
				PH0910	PH6920	PH6930
P	1	Unalloyed Steel	125-220	●	●	●
	2	Low-Alloyed Steel	220-280		●	●
	3	High-Alloyed Steel	280-380		●	●
M	4	SS - Ferritic / Martensitic	200-330			●
	5	SS - Austenitic	200-330			●
	6	SS - Austenitic-ferritic (Duplex)	230-260			●
K	7	Malleable Cast Iron	130-230		●	●
	8	Grey Cast Iron	180-245		●	●
	9	Nodular Cast iron	160-250		●	●
N	10	Aluminium and Non Ferrous	30-130	✓		

- Good Conditions
- Average Conditions
- Difficult Conditions

CHIP-BREAKER SELECTION GUIDE | Guia para aplicações do quebra-apanas | Guía para aplicación del rompevirutas

ISO	PSM	Material	HB (Brinell)	Chip-Breaker Application	
				1st choice	Difficult Operations
P	1	Unalloyed Steel	125-220	APKT 10... PDER-X	APKT 10... PDTR-X
	2	Low-Alloyed Steel	220-280	APKT 10... PDSR-X	APKT 10... PDSR-X
	3	High-Alloyed Steel	280-380	APKT 10... PDSR-X	-
M	4	SS - Ferritic / Martensitic	200-330	APKT 10... PDER-X	-
	5	SS - Austenitic	200-330	APKT 10... PDER-X	-
	6	SS - Austenitic-ferritic (Duplex)	230-260	APKT 10... PDER-X	-
K	7	Malleable Cast Iron	130-230	APKT 10... PDER-X	APKT 10... PDSR-X
	8	Grey Cast Iron	180-245	APKT 10... PDSR-X	-
	9	Nodular Cast iron	160-250	APKT 10... PDSR-X	-
N	10	Aluminium and Non Ferrous	30-130	APET 10... PDFR-LN	-

RAMPING AND HELICAL INTERPOLATION

Descida em rampa e interpolação helicoidal | Bajada en rampa e interpolación circular

Ramping

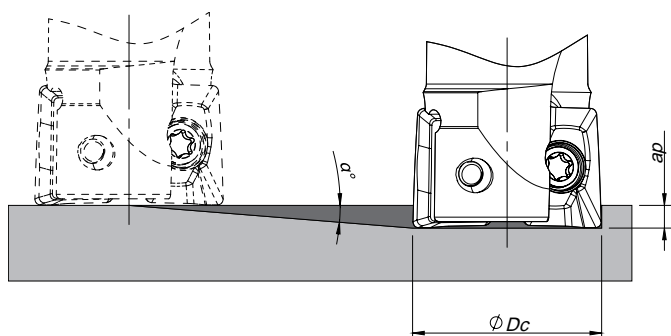

Helical Interpolation

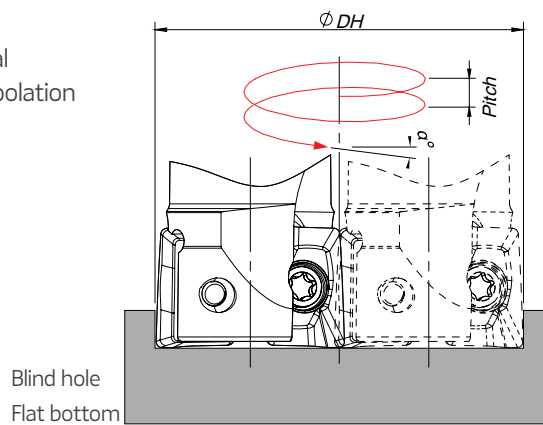

Blind hole
Flat bottom

$$\text{Ødi} = \text{ØDH} - \text{ØDc}$$

ØDc	Ramping			Helical Interpolation		
	Max Ramp α°	Max ap	Min Lr	Diameter for Blind Hole, Flat Bottom Face (1)		Max Pitch/Rev.
				ØDHmin	ØDHmax	
16	1,3	9,0	396,6	29,2	-	0,9
				-	31,0	1,1
20	0,9	9,0	572,9	37,2	-	0,8
				-	39,0	0,9
25	0,6	9,0	859,4	47,2	-	0,7
				-	49,0	0,8
40	0,4	9,0	1289,1	77,2	-	0,8
				-	79,0	0,9
50	0,25	9,0	2062,6	97,2	-	0,6
				-	99,0	0,7
63	0,2	9,0	2578,3	123,2	-	0,7
				-	125,0	0,7

(1) using LP insert with radius 0,8 mm

Note: During helical interpolation do not exceed maximum pitch

When using HF insert or other different insert radius to calculate the ØDHmin and ØDHmax use the equation below:

- Minimum Diameter: $\text{ØDHmin} = 2 \times (\text{ØDc} - (\text{R corner radius} + \text{F width of edge wiper}))$

- Maximum Diameter: $\text{ØDHmax} = 2 \times (\text{ØDc} - \text{R corner radius})$

LINEPRO 17090

RECOMMENDED CUTTING CONDITIONS | Condições de corte recomendadas | Condiciones de corte recomendables

ISO	PSM	Material	HB (Brinell)	Vc (m/min)		
				← Wear Resistance		Toughness →
				PH0910	PH6920	PH6930
P	1	Unalloyed Steel	125-220	-	180-240	160-220
	2	Low-Alloyed Steel	220-280	-	160-220	140-200
	3	High-Alloyed Steel	280-380	-	140-210	120-190
M	4	SS - Ferritic / Martensitic	200-330	-	140-220	140-200
	5	SS - Austenitic	200-330	-	130-180	120-160
	6	SS - Austenitic-ferritic (Duplex)	230-260	-	120-160	100-140
K	7	Malleable Cast Iron	130-230	-	160-260	150-240
	8	Grey Cast Iron	180-245	-	140-240	140-230
	9	Nodular Cast iron	160-250	-	120-200	100-190
N	10	Aluminium and Non Ferrous	30-130	100-2000	-	-

(Note 1) Cutting conditions $a_e/D_c=70\%$.

(Note 2) Cutting conditions for slotting and shouldering operations:

Operation	a_e	Vc & fz	a_p (mm)
Slotting	100%	<20%	3,0-4,0
	<50%	>8%	5,0-6,0
Shouldering	≤25%	>12%	7,0-8,0

(Note 3) Cutting conditions should be adjusted according to the machine and work rigidity.

(Note 4) It's possible to occur vibrations in certain cases. Please reduce depth of cut and / or reduce cutting conditions in following cases:

- When using long shank;
- When using long tool overhang with arbor type;
- When application has poor clamping rigidity or when using a low rigidity machine.

(Note 5) If chattering occurs, reduce a_p and Vc by 30% and keep the same fz per tooth.

Feed fz (mm/t)		
APKT 10... PDER-X/X1	APKT 10... PDS(T)R-X/X1	APET 10... PDFR-LN
0,07-0,15	0,10-0,25	-
0,07-0,10	0,10-0,20	-
0,07-0,10	0,10-0,20	-
0,07-0,10	-	-
0,07-0,10	-	-
0,07-0,10	-	-
0,07-0,15	0,10-0,25	-
0,07-0,15	0,10-0,25	-
-	0,10-0,20	-
-	-	0,07-0,20

A

MILLING

Overview

Face milling

Hi-feed milling

Shoulder milling

Profile milling

Hardmill

Center & Chamfer

Spot face

Spare Parts

Technical Data

End Mills

LINEPRO 18090

A

MILLING

Overview

Face milling

Hifeed milling

Shoulder milling

Profile milling

Hardmill

Center & Chamfer

Spot face

Spare Parts

Technical Data

End Mills

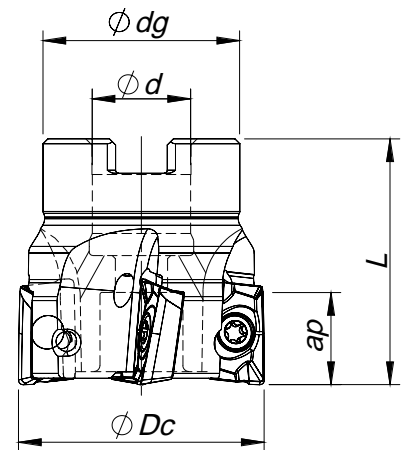
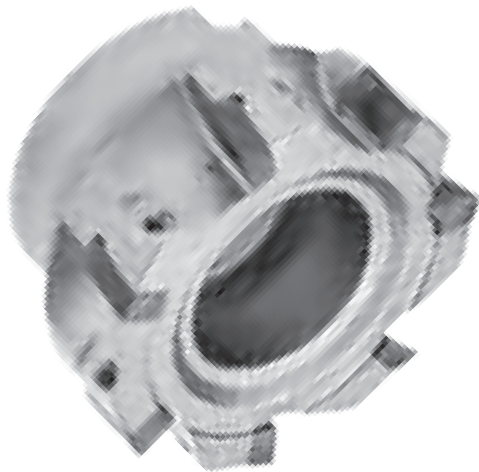

Arbor Mounting

$K_r=90^\circ$ | $\gamma_p=+8^\circ \sim +10^\circ$

Order code Código	Reference Referência Referencia		Dimensions Dimensões Dimensiones (mm)				Kg	Specifications		Insert Pastilha Inserto	Stock
			ϕDc	ϕd	ϕdg	L		Arbor Type	Ap max (mm)		
181031200	040A18090-04-08-016040	4	40	16	32	40	0,180	A	14,5	AP.. 1604	
181030900	050A18090-05-08-022040	5	50	22	42	40	0,290	A	14,5	AP.. 1604	
181031300	063A18090-06-09-022040	6	63	22	52	40	0,530	A	14,5	AP.. 1604	
181031400	080A18090-07-10-027050	7	80	27	60	50	0,920	B	14,5	AP.. 1604	
181031500	100A18090-08-10-032050	8	100	32	80	50	1,680	B	14,5	AP.. 1604	
181031600	125A18090-09-10-040063	9	125	40	90	63	3,010	B	14,5	AP.. 1604	

Stock item | Produto de stock | Itens de stock

Available under request (see page A-8) | Disponível sobre consulta (consulte a página A-8) | Disponible bajo consulta (mire página A-8)

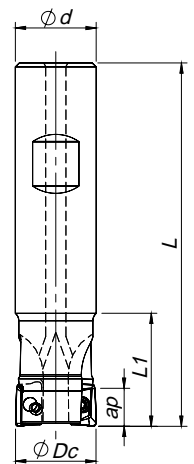

Weldon Shank

$K_r=90^\circ$ | $\gamma_p=+6^\circ \sim +8^\circ$

Order code Código	Reference Referência Referencia		Dimensions Dimensões Dimensiones (mm)				Kg	Specifications		Insert Pastilha Inserto	Stock
			ϕDc	ϕd	L	L1		Ap max (mm)			
181041800	025W18090-02-06-025100	2	25	25	100	44	0,310	14,5	AP.. 1604		
181042100	025W18090-02-06-025200	2	25	25	200	60	0,670	14,5	AP.. 1604		
181041900	032W18090-03-07-032110	3	32	32	110	50	0,560	14,5	AP.. 1604		
181042200	032W18090-03-07-032200	3	32	32	200	60	1,100	14,5	AP.. 1604		
181042000	040W18090-04-08-032115	4	40	32	115	40	0,670	14,5	AP.. 1604		
181042300	040W18090-04-08-032200	4	40	32	200	40	1,190	14,5	AP.. 1604		

Stock item | Produto de stock | Itens de stock

Available under request (see page A-8) | Disponível sobre consulta (consulte a página A-8) | Disponible bajo consulta (mire página A-8)

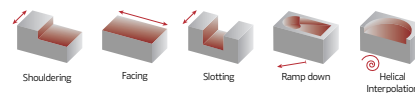

SPARE PARTS | Complementos | Repuestos

Cutter ØDc	Insert Screw	Key (Torx)	Order separately	
			Key (Torx - Nm)	Torque Value
W18090 - 25-40	P0400900	XT15	DT1530	3,0
A18090 - 40-80	P0400900	XT15	DT1530	3,0
A18090 - 100-125	P0400900	PT15	DT1530	3,0

Note: The toolholder is supplied with the XT/PT key. To order the DT key please check the page A-241. Check the procedures for the clamping screws on the page A-241.

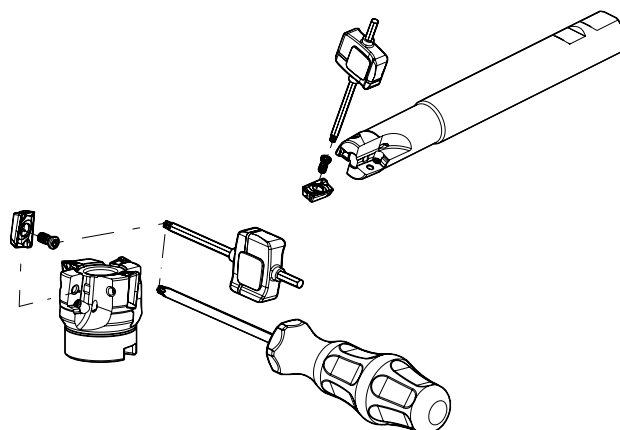

AP... 1604... | Inserts | Pastilhas | Plaquetas

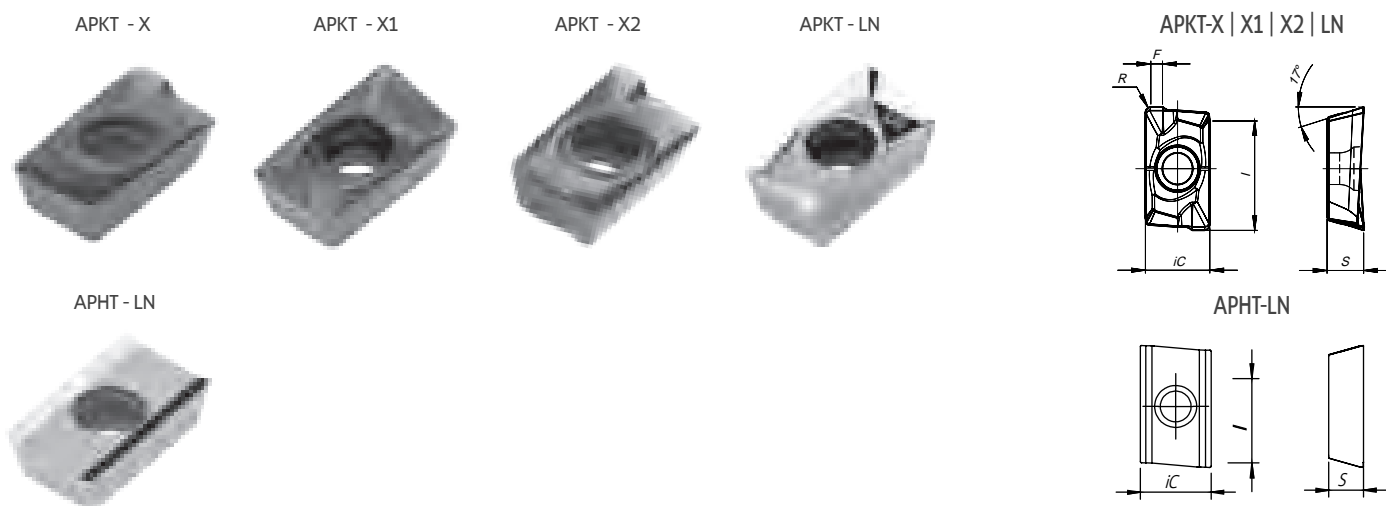

		P				M		K				N	Dimensions Dimensões Dimensiones (mm)				
		PVD				PVD		PVD				UNC					
		⁽²⁾ Grade code		68	G4	66	P3	66	P3	68	G4	66					
⁽¹⁾ Geometry code	ISO Reference	PH6920	PH7920	PH6930	PH7930	PH6930	PH7930	PH6920	PH7920	PH6930	PH7930	PH0910	iC	S	I	R	F
1112159	APKT 160408 PDER-X1	⊗		⊗		⊗		⊗		⊗			9,45	5,35	16,00	0,80	1,80
1112464	APKT 160408 PDER-X2		⊗		⊗		⊗		⊗		⊗		9,45	5,35	16,00	0,80	1,80
1112158	APKT 160408 PDSR-X1	⊗		⊗				⊗		⊗			9,45	5,35	16,00	0,80	1,80
1112367	APKT 160408 PDSR-X2		⊗		⊗				⊗		⊗		9,45	5,35	16,00	0,80	1,80
1111923	APKT 160408 PDFR-LN											⊗	9,45	5,35	16,00	0,80	0,80
1111074	APKT 160416 PDER-X	⊗						⊗					9,45	5,35	16,00	1,60	1,20
1111050	APKT 160416 PDSR-X	⊗		⊗				⊗		⊗			9,45	5,35	16,00	1,60	1,20
1111075	APKT 160432 PDER-X	⊗						⊗					9,45	5,35	16,00	3,20	-
1111052	APKT 160432 PDSR-X	⊗						⊗					9,45	5,35	16,00	3,20	-
1111924	APHT 1604 PDFR-LN											⊗	9,45	5,35	16,00	-	-

⊗ First choice | Primeira opção | 1ª opción ⊗ Stock item | Produto de stock | Itens de stock



○ Available under request (see page A-9) | Disponível sobre consulta (consulte a página A-9) | Disponible bajo consulta (mire página A-9)

Insert order code = (1) Geometry Code + (2) Grade Code

*For inserts with radius above 2.0 mm, the cutter must be adjusted

LINEPRO 18090

GRADES SELECTION GUIDE | Guia para selecção de graus | Tabla para selección de calidades

ISO	PSM	Material	HB (Brinell)	Grades		
				← Wear Resistance		Toughness →
				PH0910 	PH7(6)920 	PH7 (6)30 
P	1	Unalloyed Steel	125-220		✓	✓
	2	Low-Alloyed Steel	220-280		✓	✓
	3	High-Alloyed Steel	280-380		✓	✓
M	4	SS - Ferritic / Martensitic	200-330			✓
	5	SS - Austenitic	200-330			✓
	6	SS - Austenitic-ferritic (Duplex)	230-260			✓
K	7	Malleable Cast Iron	130-230		✓	✓
	8	Grey Cast Iron	180-245		✓	✓
	9	Nodular Cast iron	160-250		✓	✓
N	10	Aluminium and Non Ferrous	30-130	✓		

-  Good Conditions
-  Average Conditions
-  Difficult Conditions

RECOMMENDED CUTTING CONDITIONS | Condições de corte recomendadas | Condiciones de corte recomendables

ISO	PSM	Material	HB (Brinell)	Vc (m/min)		
				← Wear Resistance		Toughness →
				PH0910	PH7(6)920	PH7(6)930
P	1	Unalloyed Steel	125-220	-	180-240	160-220
	2	Low-Alloyed Steel	220-280	-	160-220	140-200
	3	High-Alloyed Steel	280-380	-	140-210	120-190
M	4	SS - Ferritic / Martensitic	200-330	-	-	140-200
	5	SS - Austenitic	200-330	-	-	120-160
	6	SS - Austenitic-ferritic (Duplex)	230-260	-	-	100-140
K	7	Malleable Cast Iron	130-230	-	160-260	150-240
	8	Grey Cast Iron	180-245	-	140-240	140-230
	9	Nodular Cast iron	160-250	-	120-200	100-190
N	10	Aluminium and Non Ferrous	30-130	100-2000	-	-

ISO	PSM	Material	HB (Brinell)	Feed fz (mm/t)		
				APKT 16... PDER-X/X2		AP...T 16... PDFR-LN
				APKT 16... PDER-X/X2	APKT 16... PDS(T)R-X/X2	AP...T 16... PDFR-LN
P	1	Unalloyed Steel	125-220	0,07-0,15	0,10-0,25	-
	2	Low-Alloyed Steel	220-280	0,07-0,10	0,10-0,20	-
	3	High-Alloyed Steel	280-380	0,07-0,10	0,10-0,20	-
M	4	SS - Ferritic / Martensitic	200-330	0,07-0,10	-	-
	5	SS - Austenitic	200-330	0,07-0,10	-	-
	6	SS - Austenitic-ferritic (Duplex)	230-260	0,07-0,10	-	-
K	7	Malleable Cast Iron	130-230	0,07-0,15	0,10-0,25	-
	8	Grey Cast Iron	180-245	0,07-0,15	0,10-0,25	-
	9	Nodular Cast iron	160-250	-	0,10-0,20	-
N	10	Aluminium and Non Ferrous	30-130	-	-	0,07-0,20

(Note 1) Cutting conditions $a_e/D_c=70\%$.

(Note 2) Cutting conditions for slotting and shouldering operations:

Operation	a_e	Vc & fz	a_p (mm)
Slotting	100%	<20%	5,0-6,0
Shouldering	<50%	>8%	6,0-9,0
	≤25%	>12%	10,0-12,5

(Note 3) Cutting conditions should be adjusted according to the machine and work rigidity.

(Note 4) It's possible to occur vibrations in certain cases. Please reduce depth of cut and / or reduce cutting conditions in following cases:

- When using long shank;
- When using long tool overhang with arbor type;
- When application has poor clamping rigidity or when using a low rigidity machine.

CHIP-BREAKER SELECTION GUIDE | Guia para aplicações do quebra- aparas | Guía para aplicación del rompevirutas

ISO	PSM	Material	HB (Brinell)	Chip-Breaker Application	
				1st choice	Difficult Operations
P	1	Unalloyed Steel	125-220	APKT 16... PDER-X(X2)	APKT 16... PDSR-X(-X2)
	2	Low-Alloyed Steel	220-280	APKT 16... PDSR-X(X2)	-
	3	High-Alloyed Steel	280-380	APKT 16... PDSR-X(X2)	-
M	4	SS - Ferritic / Martensitic	200-330	APKT 16... PDER-X(X2)	-
	5	SS - Austenitic	200-330	APKT 16... PDER-X(X2)	-
	6	SS - Austenitic-ferritic (Duplex)	230-260	APKT 16... PDSR-X(X2)	-
K	7	Malleable Cast Iron	130-230	APKT 16... PDSR-X(X2)	APKT 16... PDSR-X(X2)
	8	Grey Cast Iron	180-245	APKT 16... PDSR-X(X2)	-
	9	Nodular Cast iron	160-250	APKT 16... PDSR-X(X2)	-
N	10	Aluminium and Non Ferrous	30-130	AP...T 16... PDFR-LN	APHT 16... PDFR-LN

RAMPING AND HELICAL INTERPOLATION

Descida em rampa e interpolação helicoidal | Bajada en rampa e interpolación circular

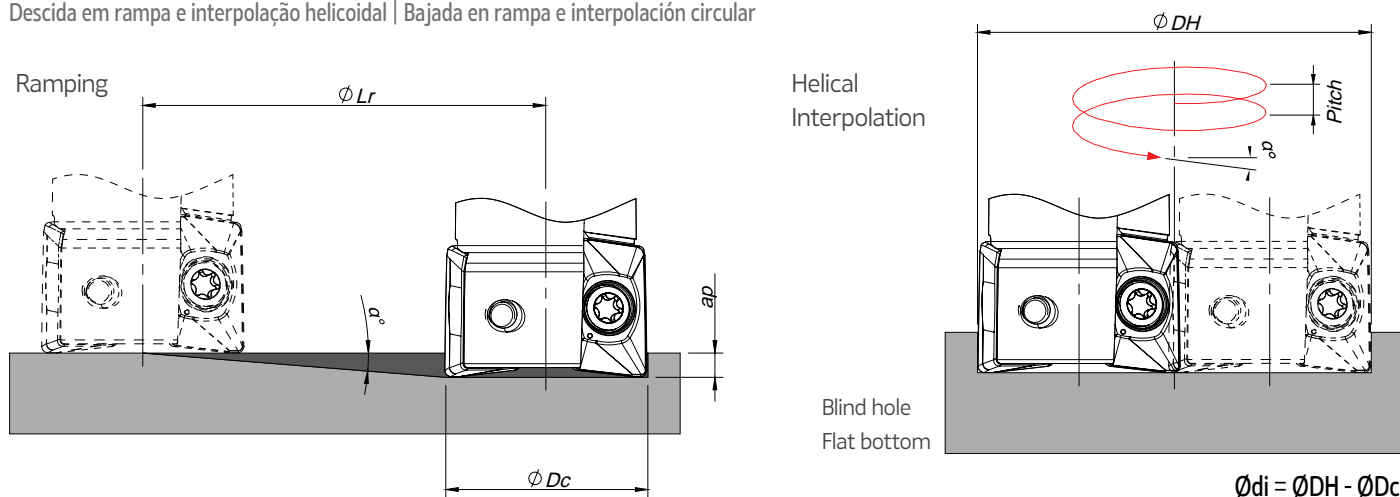

$$\phi_{di} = \phi_{DH} - \phi_{Dc}$$

ϕ_{Dc}	Ramping			Helical Interpolation		
	Max Ramp a°	Max a_p	Min L_r	Diameter for Blind Hole, Flat Bottom Face (1)		Max Pitch/Rev.
				ϕ_{DHmin}	ϕ_{DHmax}	
25	3	14,5	276,7	46,1 -	- 48,4	3,5 3,9
32	2	14,5	415,2	60,1 -	- 62,4	3,1 3,3
40	1,5	14,5	553,7	76,1 -	- 78,4	3,0 3,2
50	1,1	14,5	755,2	96,1 -	- 98,4	2,8 2,9
63	0,85	14,5	977,3	122,1 -	- 124,4	2,8 2,9
80	0,64	14,5	1298,1	156,1 -	- 158,4	2,7 2,7
100	0,5	14,5	1661,5	196,1 -	- 198,4	2,6 2,7
125	0,38	14,5	2186,3	246,1 -	- 248,4	2,5 2,6

(1) Using insert radius 0,8 mm

Note: During helical interpolation do not exceed maximum pitch

When using different insert radius to calculate the ϕ_{DHmin} and ϕ_{DHmax} use the equation below:

- Minimum Diameter: $\phi_{DHmin} = 2 \times (\phi_{Dc} - (R \text{ corner radius} + F \text{ width of edge wiper}))$

- Maximum Diameter: $\phi_{DHmax} = 2 \times (\phi_{Dc} - R \text{ corner radius})$

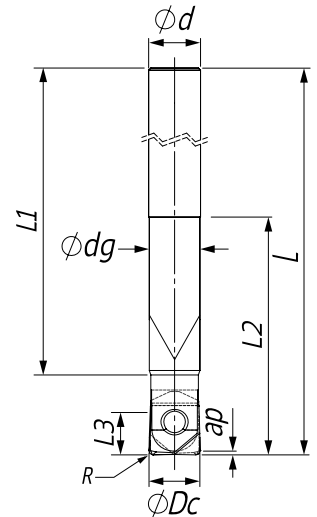

Cylindrical Carbide Shank

Tolerance R	Runout Tolerance
± 0,015	R 0,02

Order code Código	Reference Referência Referencia		Dimensions Dimensões Dimensiones (mm)						Kg	Specifications				Insert	Stock
			ØDc	Ød	Ødg	L	L1	L2		Ap max (mm)		Ae max (mm)			
181156600	008E62090-02-U008140	2	8	8	7,7	140	128	35	0,09	4,0	2,5	0,8	0,8	WCR 08../WCL 08...	
181156700	010E62090-02-U010150	2	10	10	9,7	150	136	45	0,15	5,0	3,0	1,0	1,0	WCR 10../WCL 10...	
181156800	010E62090-02-U010180	2	10	10	9,7	180	166	45	0,18	5,0	3,0	1,0	1,0	WCR 10../WCL 10...	
181155700	012E62090-02-U012165	2	12	12	11,7	165	147	55	0,24	6,0	4,0	1,2	1,2	WCR 12../WCL 12...	
181156900	012E62090-02-U012200	2	12	12	11,7	200	182	55	0,29	6,0	4,0	1,2	1,2	WCR 12../WCL 12...	
181157000	016E62090-02-U016200	2	16	16	15,7	200	180	65	0,51	8,0	5,0	1,6	1,6	WCR 16../WCL 16...	
181157100	016E62090-02-U016250	2	16	16	15,7	250	230	65	0,67	8,0	5,0	1,6	1,6	WCR 16../WCL 16...	
181157200	020E62090-02-U020220	2	20	20	19,7	220	193	70	0,87	10,0	6,0	2,0	2,0	WCR 20../WCL 20...	
181157300	020E62090-02-U020250	2	20	20	19,7	250	223	70	1,00	10,0	6,0	2,0	2,0	WCR 20../WCL 20...	
181157400	020E62090-02-U020300	2	20	20	19,7	300	273	70	1,23	10,0	6,0	2,0	2,0	WCR 20../WCL 20...	

Stock item | Produto de stock | Itens de stock

Available under request (see page A-8) | Disponível sobre consulta (consulte a página A-8) | Disponible bajo consulta (mire pagina A-8)

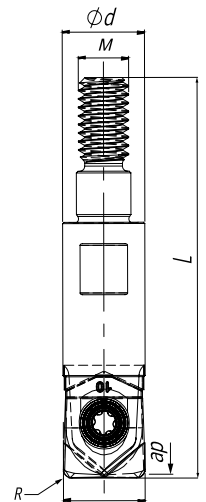

Threaded Steel Shank

Tolerance R	Runout Tolerance
± 0,015	R 0,02

Order code Código	Reference Referência Referencia		Dimensions Dimensões Dimensiones (mm)					Kg	Specifications				Insert	Stock
			ØDc	R	Ød	L	M		Ap max (mm)		Ae max (mm)			
181167000	010R62090-02-UM06030	2	10	5	6,5	30	M6	0,011	5	3,0	1,0	1,0	WCR 10../WCL 10...	
181167100	012R62090-02-UM06030	2	12	6	6,5	30	M6	0,016	6	4,0	1,2	1,2	WCR 12../WCL 12...	
181167200	016R62090-02-UM08030	2	16	8	8,5	30	M8	0,028	8	5,0	1,6	1,6	WCR 16../WCL 16...	
181167300	020R62090-02-UM10035	2	20	10	10,5	35	M10	0,058	10	6,0	2,0	2,0	WCR 20../WCL 20...	

Stock item | Produto de stock | Itens de stock

Available under request (see page A-8) | Disponível sobre consulta (consulte a página A-8) | Disponible bajo consulta (mire pagina A-8)

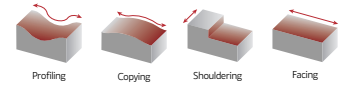

SPARE PARTS Complementos | Repuestos

Cutter ØDc	Insert Screw	Key (Torx)	Order separately	
			Key (Torx - Nm)	Torque Value
8	P0300726	XT08	DT0812	1,2
10	P0350825	XT10	DT1020	2,0
12	P0501025	XT20	DT2050	5,0
16	P0501326	XT20	DT2050	5,0
20	P0601725	XT25	-	6,9

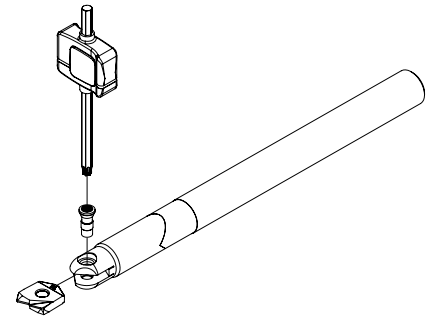

WCR | Inserts | Pastilhas | Plaquetas

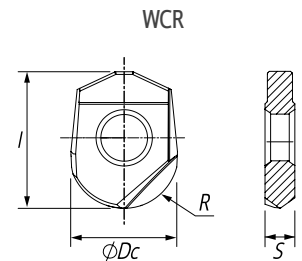

Geometry code	ISO Reference	P		M		K		H		Dimensions / Dimensões / Dimensiones (mm)			
		PVD		PVD		PVD		PVD		I	R	S	Dc
		X4	X6	X4	X6	X4	X6	X4	X6				
1112900	WCR 08	⊗	⊗	⊗	⊗	⊗	⊗	⊗	⊗	9,7	4,0	2,1	8,0
1111914	WCR 10	⊗	⊗	⊗	⊗	⊗	⊗	⊗	⊗	12,0	5,0	2,7	10,0
1112099	WCR 12	⊗	⊗	⊗	⊗	⊗	⊗	⊗	⊗	14,6	6,0	3,2	12,0
1112100	WCR 16	⊗	⊗	⊗	⊗	⊗	⊗	⊗	⊗	16,6	8,0	4,2	16,0
1112101	WCR 20	⊗	⊗	⊗	⊗	⊗	⊗	⊗	⊗	20,0	10,0	5,2	20,0

⊗ First choice | Primeira opção | 1ª opción
 ⊗ Stock item | Produto de stock | Itens de stock
 ○ Available under request (see page A-9) | Disponível sobre consulta (consulte a página A-9) | Disponible bajo consulta (mire pagina A-9)
 Insert order code = (1) Geometry Code + (2) Grade Code



A
MILLING
Overview
Face milling
Hifed milling
Shoulder milling
Profile milling
Hardmill
Center & Chamfer
Spot face
Spare Parts
Technical Data
End Mills

WCL | Inserts | Pastilhas | Plaquetas

WCL

NEW



WCL

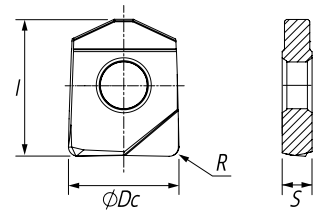

		P		M		K		H		Dimensions Dimensões Dimensiones (mm)			
		PVD		PVD		PVD		PVD		l	R	S	Dc
		X4	X6	X4	X6	X4	X6	X4	X6				
(1) Geometry code	(2) Grade code	PHH603	PHH910	PHH603	PHH910	PHH603	PHH910	PHH603	PHH910				
1112879	WCL-08 R0.3	⊗	⊗	⊗	⊗	⊗	⊗	⊗	⊗	9,7	0,3	2,1	8
1112880	WCL-08 R0.5	⊗	⊗	⊗	⊗	⊗	⊗	⊗	⊗	9,7	0,5	2,1	08
1112853	WCL-08 R1.0	⊗	⊗	⊗	⊗	⊗	⊗	⊗	⊗	9,7	1,0	2,1	08
1112881	WCL-10 R0.3	⊗	⊗	⊗	⊗	⊗	⊗	⊗	⊗	12,0	0,3	2,7	10
1112882	WCL-10 R0.5	⊗	⊗	⊗	⊗	⊗	⊗	⊗	⊗	12,0	0,5	2,7	10
1112848	WCL-10 R1.0	⊗	⊗	⊗	⊗	⊗	⊗	⊗	⊗	12,0	1,0	2,7	10
1112883	WCL-10 R1.5	⊗	⊗	⊗	⊗	⊗	⊗	⊗	⊗	12,0	1,5	2,7	10
1112884	WCL-10 R2.0	⊗	⊗	⊗	⊗	⊗	⊗	⊗	⊗	12,0	2,0	2,7	10
1112885	WCL-12 R0.3	⊗	⊗	⊗	⊗	⊗	⊗	⊗	⊗	14,6	0,3	3,2	12
1112886	WCL-12 R0.5	⊗	⊗	⊗	⊗	⊗	⊗	⊗	⊗	14,6	0,5	3,2	12
1112096	WCL-12 R1.0	⊗	⊗	⊗	⊗	⊗	⊗	⊗	⊗	14,6	1,0	3,2	12
1112887	WCL-12 R1.5	⊗	⊗	⊗	⊗	⊗	⊗	⊗	⊗	14,6	1,5	3,2	12
1112888	WCL-12 R2.0	⊗	⊗	⊗	⊗	⊗	⊗	⊗	⊗	14,6	2,0	3,2	12
1112889	WCL-12 R3.0	⊗	⊗	⊗	⊗	⊗	⊗	⊗	⊗	14,6	3,0	3,2	12
1112890	WCL-16 R0.3	⊗	⊗	⊗	⊗	⊗	⊗	⊗	⊗	16,6	0,3	4,2	16
1112891	WCL-16 R0.5	⊗	⊗	⊗	⊗	⊗	⊗	⊗	⊗	16,6	0,5	4,2	16
1112097	WCL-16 R1.0	⊗	⊗	⊗	⊗	⊗	⊗	⊗	⊗	16,6	1,0	4,2	16
1112892	WCL-16 R1.5	⊗	⊗	⊗	⊗	⊗	⊗	⊗	⊗	16,6	1,5	4,2	16
1112893	WCL-16 R2.0	⊗	⊗	⊗	⊗	⊗	⊗	⊗	⊗	16,6	2,0	4,2	16
1112894	WCL-16 R3.0	⊗	⊗	⊗	⊗	⊗	⊗	⊗	⊗	16,6	3,0	4,2	16
1112895	WCL-20 R0.3	⊗	⊗	⊗	⊗	⊗	⊗	⊗	⊗	20,0	0,3	5,2	20
1112896	WCL-20 R0.5	⊗	⊗	⊗	⊗	⊗	⊗	⊗	⊗	20,0	0,5	5,2	20
1112098	WCL-20 R1.0	⊗	⊗	⊗	⊗	⊗	⊗	⊗	⊗	20,0	1,0	5,2	20
1112897	WCL-20 R1.5	⊗	⊗	⊗	⊗	⊗	⊗	⊗	⊗	20,0	1,5	5,2	20
1112898	WCL-20 R2.0	⊗	⊗	⊗	⊗	⊗	⊗	⊗	⊗	20,0	2,0	5,2	20
1112899	WCL-20 R3.0	⊗	⊗	⊗	⊗	⊗	⊗	⊗	⊗	20,0	3,0	5,2	20

⊗ First choice | Primeira opção | 1ª opción
 ⊗ Stock item | Produto de stock | Itens de stock
 ○ Available under request (see page A-9) | Disponível sobre consulta (consulte a página A-9) | Disponible bajo consulta (mire página A-9)
 Insert order code = (1) Geometry Code + (2) Grade Code

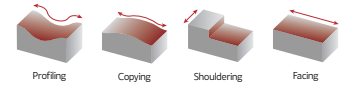

GRADES SELECTION GUIDE | Guia para selecção de graus | Tabla para selección de calidades

ISO	PSM	Material	HB (Brinell)	Grades		
				← Wear Resistance		Toughness →
				PHH603	PHH910	
P	1	Unalloyed Steel	125-220	●	●	
	2	Low-Alloyed Steel	220-280	✓	✓	
	3	High-Alloyed Steel	280-380	✓	✓	
M	4	SS - Ferritic / Martensitic	200-330	✓	✓	
	5	SS - Austenitic	200-330	✓	✓	
	6	SS - Austenitic-ferritic (Duplex)	230-260	✓	✓	
K	7	Malleable Cast Iron	130-230	✓	✓	
	8	Grey Cast Iron	180-245	✓	✓	
	9	Nodular Cast iron	160-250	✓	✓	
H	12	Hardened Steels	40-55 HRC	✓	✓	

● Good Conditions
 ● Average Conditions
 ● Difficult Conditions

RECOMMENDED CUTTING CONDITIONS | Condições de corte recomendadas | Condiciones de corte recomendables

ISO	PSM	Material	HB (Brinell)	Vc (m/min)		Feed fz (mm/t)	
				← Wear Resistance		Toughness →	
				PHH603	PHH910	WCR	WCL
P	1	Unalloyed Steel	125-220	180-310	140-270	0,15-0,45	0,10-0,30
	2	Low-Alloyed Steel	220-280	180-300	140-260	0,15-0,40	0,10-0,25
	3	High-Alloyed Steel	280-380	180-280	140-220	0,10-0,40	0,10-0,25
M	4	SS - Ferritic / Martensitic	200-330	170-300	130-260	0,15-0,35	0,10-0,25
	5	SS - Austenitic	200-330	160-290	120-250	0,15-0,35	0,10-0,25
	6	SS - Austenitic-ferritic (Duplex)	230-260	150-270	110-230	0,15-0,30	0,08-0,20
K	7	Malleable Cast Iron	130-230	200-380	180-370	0,10-0,50	0,10-0,35
	8	Grey Cast Iron	180-245	180-360	180-350	0,10-0,45	0,10-0,30
	9	Nodular Cast iron	160-250	160-310	160-290	0,10-0,40	0,10-0,30
H	12	Hardened Steels	46-54 HRC	90-270	80-260	0,05-0,20	0,05-0,15
	13	Hardened Steels	55-62 HRC	80-200	70-180	0,05-0,15	0,04-0,12
	14	Hardened Steels	63-70 HRC	70-180	70-160	0,04-0,12	0,04-0,10

PROCEDURES FOR CLAMPING SCREWS | Procedimientos para parafusos de aperto | Procedimientos para sujetar tornillos

1. Check the insert seat.
Before assembly cutter it is important to ensure that the insert seat has not been damaged during machining or handling.
2. Clean the insert seat.
Make sure that the insert seat is free from dust or chips from previous machining. If necessary, clean the insert seat with pressurised air.
3. Position the insert.
Position the insert with the top face marking in the direction of screw placement and couple the insert into the cutter.
4. Lubricate the insert screw.
Apply sufficient screw lubrication to prevent seizure. Lubricant should be applied in small quantity to the screw threads.
5. Always use a torque wrench to ensure that screws are correctly tightened (please confirm torque data). Excessive torque will negatively affect the performance of the tool and can cause screw and insert breakage. Unsuccessful torque leads to insert movement, vibration and degrade the cutting result. Dedicated adjustable torque wrench can be ordered separately. Please do not press down the insert during tightening process.

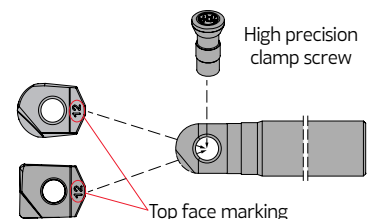

Note: Always replace worn or damaged screws.

BALLPRO 93090

NEW

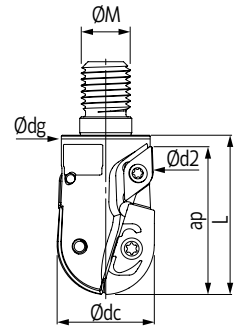
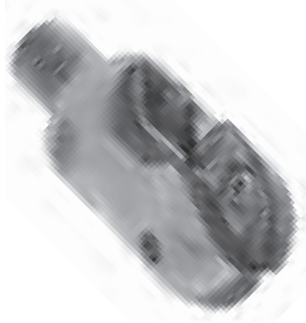

Threaded Coupling

Order code Código	Reference Referência Referencia		Dimensions Dimensões Dimensiones (mm)					Specifications Ap max (mm)	Kg	Insert	Insert 2	Stock
			ØDc	ØDc2	Ød/M	Ødg	L					
181125000	032R63090-02-M16052	2	32	31,9	M16	29	52	48	0,168	XPGT 3206	DCMW 11T3	

Stock item | Produto de stock | Itens de stock

Available under request (see page A-8) | Disponível sobre consulta (consulte a página A-8) | Disponible bajo consulta (mire pagina A-8)

XPGT 3206

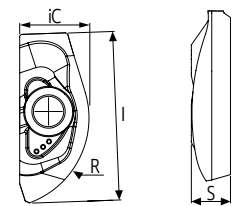

(1) Geometry code	(2) Grade code	P M K S					Dimensions (mm)			
		G4	G6	G6	G4	G6	iC	S	I	R
1112485	XPGT 3206-MP						12,576	7	30,6	16

First choice | Primeira opção | 1ª opción

Stock item | Produto de stock | Itens de stock

Available under request (see page A-9) | Disponível sobre consulta (consulte a página A-9) | Disponible bajo consulta (mire pagina A-9)

Insert order code = (1) Geometry Code + (2) Grade Code

DCMW 11T3

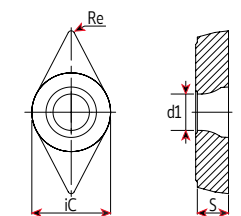
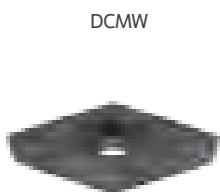

(1) Geometry code	(2) Grade code	L5	Dimensions (mm)			
			iC	S	Re	d1
1120305	DCMW 11T304		9,525	3,97	0,4	4,4

First choice | Primeira opção | 1ª opción

Stock item | Produto de stock | Itens de stock

Available under request (see page A-9) | Disponível sobre consulta (consulte a página A-9) | Disponible bajo consulta (mire pagina A-9)

Insert order code = (1) Geometry Code + (2) Grade Code

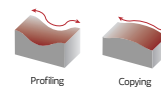

SPARE PARTS || Complementos | Repuestos

Order separately

Insert	Insert Screw	Key (Torx)	Key (Torx - Nm)	Torque Value
XPGT	P0501302	PT20	DT2050	5.0 Nm
DCMW	P0400900	XT15	DT1530	3.0 Nm

GRADES SELECTION GUIDE || Guia para selecção de graus | Tabla para selección de calidades

ISO	PSM	Material	HB (Brinell)	Grades		
				← Wear Resistance		Toughness →
				PH7920	PH7740	
P	1	Unalloyed Steel	125-220	✓	✓	
	2	Low-Alloyed Steel	220-280	✓	✓	
	3	High-Alloyed Steel	280-380	✓	✓	
M	4	SS - Ferritic / Martensitic	200-330		✓	
	5	SS - Austenitic	200-330		✓	
	6	SS - Austenitic-ferritic (Duplex)	230-260		✓	
K	7	Malleable Cast Iron	130-230	✓		
	8	Grey Cast Iron	180-245	✓		
	9	Nodular Cast iron	160-250	✓		
S	11	Heat Resistant Super Alloys	200-320		✓	

Good Conditions
 Average Conditions
 Difficult Conditions

RECOMMENDED CUTTING CONDITIONS || Condições de corte recomendadas | Condiciones de corte recomendadas

ISO	PSM	Material	HB (Brinell)	Vc (m/min)		Feed fz (mm/t)	
				← Wear Resistance			Toughness →
				PH7920	PH7740		
P	1	Unalloyed Steel	125-220	190-350	140-300	0,10-0,90	
	2	Low-Alloyed Steel	220-280	180-280	130-230	0,10-0,85	
	3	High-Alloyed Steel	280-380	150-220	100-180	0,05-0,80	
M	4	SS - Ferritic / Martensitic	200-330	-	120-260	0,05-0,80	
	5	SS - Austenitic	200-330	-	100-200	0,05-0,80	
	6	SS - Austenitic-ferritic (Duplex)	230-260	-	60-120	0,05-0,60	
K	7	Malleable Cast Iron	130-230	240-380	-	0,15-0,90	
	8	Grey Cast Iron	180-245	220-320	-	0,15-0,90	
	9	Nodular Cast iron	160-250	180-280	-	0,10-0,80	
S	11	Heat Resistant Super Alloys	200-320	-	30-110	0,10-0,80	



A

MILLING

Overview

Face milling

Hifeed milling

Shoulder milling

Profile milling

Hardmill

Center & Chamfer

Spot face

Spare Parts

Technical Data

End Mills



Threaded Coupling

$\kappa_r = 95^\circ$ | $\gamma_p = -7^\circ$

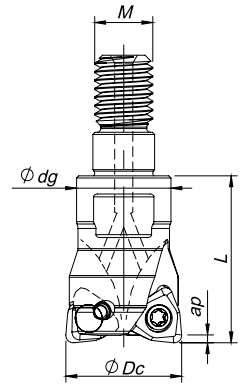

Order code Código	Reference Referência Referencia		Dimensions Dimensões Dimensiones (mm)				Kg	Specifications	Insert Pastilha Inserto	Stock
			ØDc	M	Ødg	L		Ap max (mm)		
181030400	016R49095-02-07-M08023	2	16	M8	13	23	0,024	0,30	WNHU 04T310	
181028600	020R49095-03-07-M10028	3	20	M10	18	28	0,052	0,30	WNHU 04T310	
181030500	025R49095-04-07-M12030	4	25	M12	21	30	0,082	0,30	WNHU 04T310	
181030600	035R49095-05-07-M16035	5	35	M16	29	35	0,190	0,30	WNHU 04T310	

Stock item | Produto de stock | Itens de stock

Available under request (see page A-8) | Disponível sobre consulta (consulte a página A-8) | Disponible bajo consulta (mire pagina A-8)

WNHU 04T310 | Inserts | Pastilhas | Plaquetas

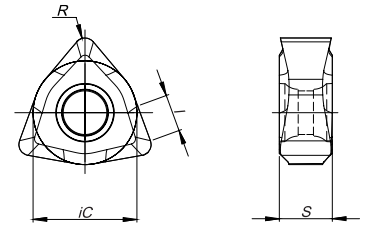

		P		K		H		Dimensions Dimensões Dimensiones (mm)			
		PVD		PVD		PVD		iC	S	I	R
⁽¹⁾ Geometry code	⁽²⁾ Grade code	X5	G4	X5	G4	X4	X5				
1110783	WNHU 04T310							6,35	3,50	2,80	1,00

First choice | Primeira opção | 1ª opción Stock item | Produto de stock | Itens de stock

Available under request (see page A-9) | Disponível sobre consulta (consulte a página A-9) | Disponible bajo consulta (mire pagina A-9)

Insert order code = (1) Geometry Code + (2) Grade Code

SPARE PARTS | Complementos | Repuestos

Cutter ØDc	Order separately			
	Insert Screw	Key (Torx)	Key (Torx - Nm)	Torque Value
R49095 - 16-35	P0250704	XT08	DT0812	1,2

Note: The toolholder is supplied with the XT/PT key. To order the DT key please check the page A-241.
Check the procedures for the clamping screws on the page A-241.

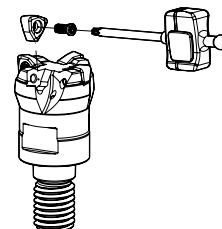



GRADES SELECTION GUIDE | Guia para selecção de graus | Tabla para selección de calidades

ISO	PSM	Material	HB (Brinell)	Grades		
				← Wear Resistance		Toughness →
				PHH603	PHP910	PH7920
P	1	Unalloyed Steel	125-220	●	✓	✓
	2	Low-Alloyed Steel	220-280		✓	✓
	3	High-Alloyed Steel	280-380	✓	✓	✓
K	7	Malleable Cast Iron	130-230		✓	✓
	8	Grey Cast Iron	180-245		✓	✓
	9	Nodular Cast iron	160-250		✓	✓
H	12	Hardened Steels	40-55 HRC	✓		

- Good conditions
- Average Conditions
- Difficult Conditions

(Note 1) Grade PHH603 must be used only on finishing operations.

RECOMMENDED CUTTING CONDITIONS | Condições de corte recomendadas | Condiciones de corte recomendables

ISO	PSM	Material	HB (Brinell)	Vc (m/min)		
				← Wear Resistance		Toughness →
				PHH603	PHP910	PH7920
P	1	Unalloyed Steel	125-220	-	180-250	180-240
	2	Low-Alloyed Steel	220-280	-	160-240	160-220
	3	High-Alloyed Steel	280-380	180-310	140-230	140-210
K	7	Malleable Cast Iron	130-230	-	180-300	160-260
	8	Grey Cast Iron	180-245	-	160-250	140-240
	9	Nodular Cast iron	160-250	-	150-210	120-200
H	12	Hardened Steels	40-55 HRC	70-270	-	-

(Note 1) Grade PHH603 must be used only on finishing operations.

Insert	Feed f_z (mm/t)		a_p Rec.
	Roughing	Finishing	
WNHU 04T310	0.15-0.25	0.10-0.20	0.10-0.50

(Note 1) Cutting conditions should be adjusted according to the machine and work rigidity.

(Note 2) If chattering occurs, reduce a_p and V_c by 30% and keep the same f_z per tooth.

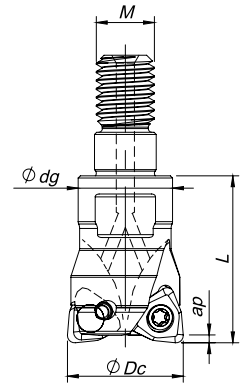
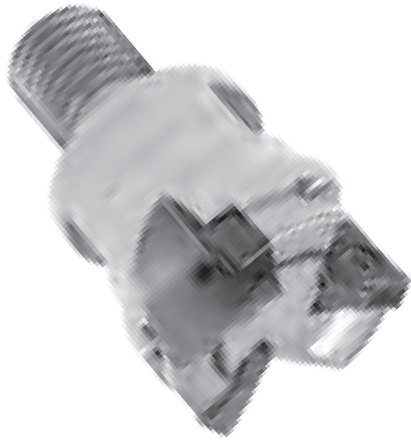

Threaded Coupling

$K_r = 95^\circ$ | $\gamma_p = -6^\circ$

Order code Código	Reference Referência Referencia		Dimensions Dimensões Dimensiones (mm)				Kg	Specifications	Insert Pastilha Inserto	Stock
			ϕDc	M	ϕdg	L		Ap max (mm)		
181037500	025R45095-02-06-M12030	2	25	M12	21	30	0,079	0,50	WNHU 060410	
181037600	035R45095-03-06-M16035	3	35	M16	29	35	0,185	0,50	WNHU 060410	
181037700	042R45095-04-06-M16035	4	42	M16	29	35	0,219	0,50	WNHU 060410	

Stock item | Produto de stock | Itens de stock

Available under request (see page A-8) | Disponível sobre consulta (consulte a página A-8) | Disponible bajo consulta (mire pagina A-8)

WNHU 060410 | Inserts | Pastilhas | Plaquetas

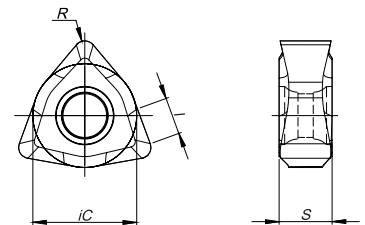

	⁽²⁾ Grade code	P	K	H		Dimensions Dimensões Dimensiones (mm)			
		PVD	PVD	PVD		iC	S	I	R
⁽¹⁾ Geometry code	ISO Reference	PHP910	PHP910	PHH603	PHP910				
1111424	WNHU 060410					9,53	4,76	3,40	1,00

First choice | Primeira opção | 1ª opción

Stock item | Produto de stock | Itens de stock

Available under request (see page A-9) | Disponível sobre consulta (consulte a página A-9) | Disponible bajo consulta (mire pagina A-9)

Insert order code = (1) Geometry Code + (2) Grade Code

SPARE PARTS | Complementos | Repuestos

Cutter ϕDc	Order separately			
	Insert Screw	Key (Torx)	Key (Torx - Nm)	Torque Value
R45095 - 25-42	P0350902	XT10	DT1020	2,0

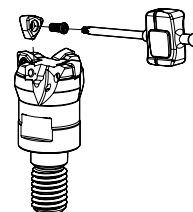

Note: The toolholder is supplied with the XT/PT key. To order the DT key please check the page A-241. Check the procedures for the clamping screws on the page A-241.



GRADES SELECTION GUIDE | Guia para selecção de graus | Tabla para selección de calidades

ISO	PSM	Material	HB (Brinell)	Grades		
				← Wear Resistance		Toughness →
				PHH603	PHP910	
P	1	Unalloyed Steel	125-220	●	✓	
	2	Low-Alloyed Steel	220-280		✓	
	3	High-Alloyed Steel	280-380	✓	✓	
K	7	Malleable Cast Iron	130-230		✓	
	8	Grey Cast Iron	180-245		✓	
	9	Nodular Cast iron	160-250		✓	
H	12	Hardened Steels	40-55 HRC	✓	✓	

- Good Conditions
- Average Conditions
- Difficult Conditions

(Note 1) Grade PHH603 must be used only on finishing operations.

RECOMMENDED CUTTING CONDITIONS | Condições de corte recomendadas | Condiciones de corte recomendables

ISO	PSM	Material	HB (Brinell)	Vc (m/min)		
				← Wear Resistance		Toughness →
				PHH603	PHP910	
P	1	Unalloyed Steel	125-220	-	180-250	
	2	Low-Alloyed Steel	220-280	-	160-240	
	3	High-Alloyed Steel	280-380	180-310	140-230	
K	7	Malleable Cast Iron	130-230	-	180-300	
	8	Grey Cast Iron	180-245	-	160-250	
	9	Nodular Cast iron	160-250	-	150-210	
H	12	Hardened Steels	40-55 HRC	70-270	60-250	

(Note 1) Grade PHH603 must be used only on finishing operations.

Insert	Feed f_z (mm/t)		a_p Rec.
	Roughing	Finishing	
WNHU 060410	0.15-0.30	0.10-0.25	0.10-0.50

(Note 1) Cutting conditions should be adjusted according to the machine and work rigidity.

(Note 2) If chattering occurs, reduce a_p and V_c by 30% and keep the same f_z per tooth.

A

MILLING

Overview

Face milling

Hi-feed milling

Shoulder milling

Profile milling

Hardmill

Center & Chamfer

Spotface

Spare Parts

Technical Data

End Mills

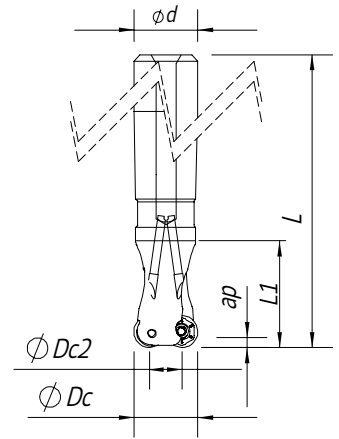

Cylindrical Shank

$\gamma_p = +5^\circ$

Order code Código	Reference Referência Referencia		Dimensions Dimensões Dimensiones (mm)					Kg	Specifications	Insert Pastilha Inserto	Stock
			ϕDc	$\phi Dc2$	ϕd	L	L1		A_p max (mm)		
33590											
181122500	016E33590-02-04-016160	2	16	8	16	160	59	0,23	4,0	RD...0802 MOE	
181122600	020E33590-03-05-020180	3	20	12	20	180	59	0,36	4,0	RD...0802 MOE	
181122700	025E33590-04-05-025200	4	25	17	25	200	59	0,65	4,0	RD...0802 MOE	
33690											
181123400	020E33690-02-05-020180	2	20	10	20	180	50	0,40	5,0	RP...10T3 MOE	
181123500	025E33690-03-05-025200	3	25	15	25	200	60	0,76	5,0	RP...10T3 MOE	
181123600	032E33690-04-05-032200	4	32	22	32	200	60	0,98	5,0	RP...10T3 MOE	

Stock item | Produto de stock | Itens de stock

Available under request (see page A-8) | Disponível sobre consulta (consulte a página A-8) | Disponible bajo consulta (mire pagina A-8)

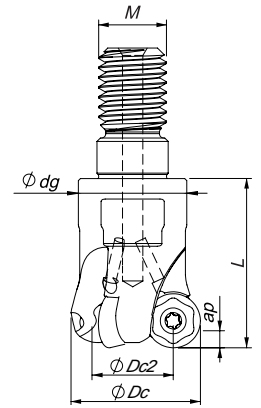

Threaded Coupling

$\gamma_p = +5^\circ$

Order code Código	Reference Referência Referencia		Dimensions Dimensões Dimensiones (mm)					Kg	Specifications	Insert Pastilha Inserto	Stock
			ϕDc	$\phi Dc2$	ϕM	ϕdg	L		A_p max (mm)		
33590											
181098600	016R33590-02-04-M08020	2	16	8	M8	13	20	0,03	4,0	RD...0802 MOE	
181122800	020R33590-03-05-M10025	3	20	12	M10	16	25	0,07	4,0	RD...0802 MOE	
181122900	025R33590-04-05-M12030	4	25	17	M12	21	30	0,14	4,0	RD...0802 MOE	
181123000	032R33590-05-05-M16043	5	32	24	M16	29	43	0,25	4,0	RD...0802 MOE	
33690											
181110600	020R33690-02-05-M10032	2	20	10	M10	16	32	0,10	5,0	RP...10T3 MOE	
181110700	025R33690-03-05-M12035	3	25	15	M12	21	35	0,19	5,0	RP...10T3 MOE	
181110800	032R33690-04-05-M16035	4	32	22	M16	29	35	0,31	5,0	RP...10T3 MOE	
181120700	035R33690-05-05-M16045	5	35	25	M16	29	45	0,40	5,0	RP...10T3 MOE	

Available under request (see page A-8) | Disponível sobre consulta (consulte a página A-8) | Disponible bajo consulta (mire pagina A-8)

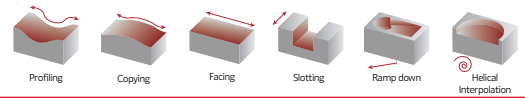

Arbor Mounting
 $\gamma_p = +5^\circ$

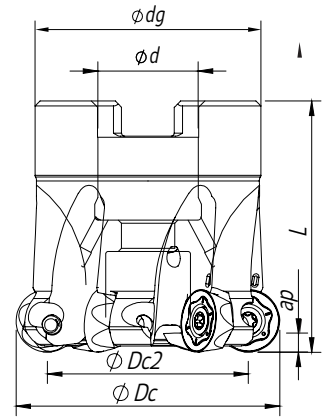

Order code Código	Reference Referência Referencia		Dimensions Dimensões Dimensiones (mm)					Kg	Specifications		Insert Pastilha Inserto	Stock
			ϕDc	$\phi Dc2$	$\phi d/M$	ϕdg	L		Arbor Type	Ap max (mm)		
33690												
181123700	042A33690-06-05-016040	6	42	32	16	36	40	0,16	A	5,0	RP...10T3 MOE	
181123800	050A33690-06-05-022040	6	50	40	22	42	40	0,26	A	5,0	RP...10T3 MOE	
181123900	052A33690-07-05-022040	7	52	42	22	42	40	0,30	A	5,0	RP...10T3 MOE	
33790												
181098700	040A33790-04-05-016040	4	40	28	26	36	40	0,15	A	6,0	RP...1204 MOE	
181111500	050A33790-04-05-022040	4	50	38	22	42	40	0,20	A	6,0	RP...1204 MOE	
181124200	052A33790-05-05-022040	5	52	40	22	42	40	0,25	A	6,0	RP...1204 MOE	
181122100	063A33790-06-05-022040	6	63	51	22	48	40	0,36	A	6,0	RP...1204 MOE	
181124300	066A33790-06-05-027050	6	66	54	27	48	50	0,40	A	6,0	RP...1204 MOE	
181124400	080A33790-07-05-027050	7	80	68	27	60	50	0,68	A	6,0	RP...1204 MOE	

Stock item | Produto de stock | Itens de stock

Available under request (see page A-8) | Disponível sobre consulta (consulte a página A-8) | Disponible bajo consulta (mire pagina A-8)



Arbor Mounting

$$\gamma_p = 5^\circ$$

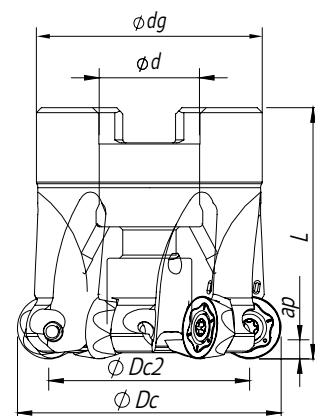

Order code Código	Reference Referência Referencia		Dimensions Dimensões Dimensiones (mm)					Kg	Specifications		Insert Pastilha Inserto	Stock
			ϕDc	$\phi Dc2$	ϕd	ϕdg	L		Arbor Type	Ap max (mm)		
33890												
181124500	050A33890-04-05-022040	4	50	34	22	42	40	0,21	A	8,0	RP...1605 MOE	○
181124600	052A33890-04-05-022040	4	52	36	22	42	40	0,25	A	8,0	RP...1605 MOE	○
181114900	063A33890-05-05-022040	5	63	47	22	48	40	0,37	A	8,0	RP...1605 MOE	⊗
181124700	066A33890-05-05-027050	5	66	54	27	48	50	0,46	A	8,0	RP...1605 MOE	⊗
181124800	080A33890-06-05-027052	6	80	64	27	60	52	0,85	A	8,0	RP...1605 MOE	⊗
181124900	100A33890-07-05-032052	7	100	84	32	80	52	1,57	A	8,0	RP...1605 MOE	⊗
181122200	125A33890-08-05-040052	8	125	109	40	90	52	2,12	A	8,0	RP...1605 MOE	⊗
33990												
181112200	080A33990-05-05-027050	5	80	60	27	60	50	0,73	A	10,0	RP...2006 MOE	⊗
181099800	100A33990-06-05-032063	6	100	80	32	80	63	1,62	A	10,0	RP...2006 MOE	⊗
181099900	125A33990-06-05-040063	6	125	105	40	90	63	2,53	A	10,0	RP...2006 MOE	⊗

⊗ Stock item | Produto de stock | Itens de stock

○ Available under request (see page A-8) | Disponível sobre consulta (consulte a página A-8) | Disponible bajo consulta (mire pagina A-8)

RDHT | RPHT | Inserts | Pastilhas | Plaquetas

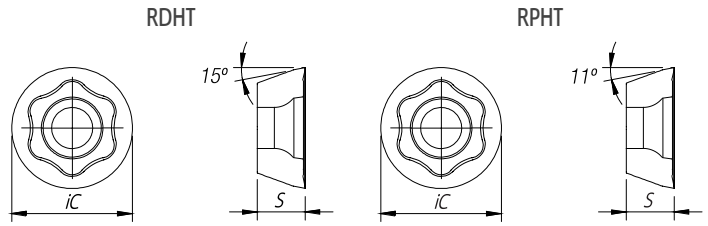

(1) Geometry code	(2) Grade code ISO Reference	P				M				S			Dimensions Dimensões Dimensiones (mm)	
		CVD	PVD			PVD				PVD				
		T9	T1	Z1	Z2	X9	Y2	Z2	Z3	X9	Y2	Z3	iC	S
1112152	RDHT 0802 M0E-LS				⊗				⊗	⊗		⊗	8,00	2,38
1112253	RPHT 10T3 M0E-MS		⊗			⊗					⊗		10,00	3,97
1112772	RPHT 10T3 M0E-LS	⊗		⊗	⊗		⊗	⊗	⊗		⊗	⊗	10,00	3,97
1112186	RPHT 1204 M0E-MS		⊗			⊗				⊗			12,00	4,76
1112766	RPHT 1204 M0E-LS	⊗		⊗	⊗		⊗	⊗	⊗		⊗	⊗	12,00	4,76
1112254	RPHT 1605 M0E-MS		⊗			⊗				⊗			16,00	5,56
1112951	RPHT 1605 M0E-LS			⊗	⊗		⊗	⊗	⊗		⊗	⊗	16,00	5,56
1112958	RPHT 2006 M0E-LS				⊗		⊗	⊗	⊗		⊗	⊗	20,00	6,35

⊗ First choice | Primeira opção | 1ª opción ⊗ Stock item | Produto de stock | Itens de stock ○ Available under request (see page A-9) | Disponível sobre consulta (consulte a página A-9) | Disponible bajo consulta (mire página A-9) Insert order code = (1) Geometry Code + (2) Grade Code

SPARE PARTS | Complementos | Repuestos

Cutter ØDc	Insert Screw	Key (Torx)	Order separately	
			Key (Torx - Nm)	Torque Value
33590	P0250503	XT08	DT0812	1,20
33690	P0300800	XT09	DT0914	1,40
33790	P0350800	XT15	DT1530	3,00
33890	P0451100	XT20	DT2050	5,00
33990	P0501302	PT20	DT2050	5,00

Note: The toolholder is supplied with the XT/PT key. To order the DT key please check the page A-241.
Check the procedures for the clamping screws on the page A-241.

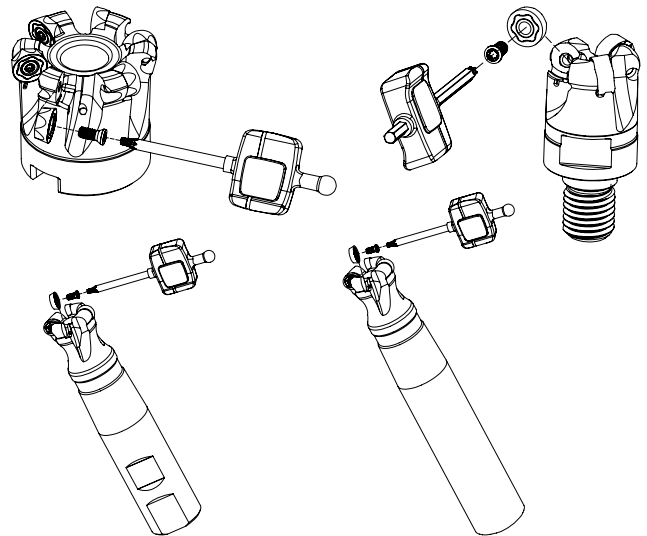

TURBOMILL 34190

NEW

Proprietary milling line

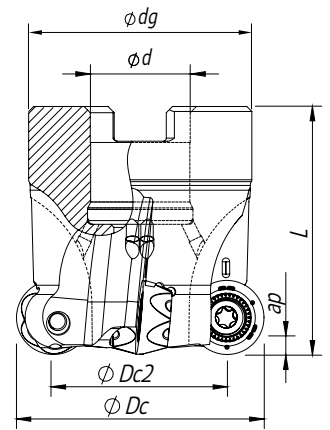

Arbor Mounting

$$\gamma_p = 5^\circ$$

Order code Código	Reference Referência Referencia		Dimensions Dimensões Dimensiones (mm)					Kg	Specifications		Insert	Stock
			ϕDc	$\phi Dc2$	ϕd	ϕdg	L		Arbor Type	A_p max (mm)		
181160100	042A34190-06-05-016040		42	32	16	36	40	0,16	A	5	RPHT 10T3M0E-LS(4)	
181160200	050A34190-06-05-022039		50	40	22	42	40	0,26	A	5	RPHT 10T3M0E-LS(4)	
181160700	052 A34190-07-05-022040		52	42	22	42	40	0,30	A	5	RPHT 10T3M0E-LS(4)	

Stock item | Produto de stock | Itens de stock

Available under request (see page A-8) | Disponível sobre consulta (consulte a página A-8) | Disponible bajo consulta (mire página A-8)

TURBOMILL 34290

NEW

Proprietary milling line

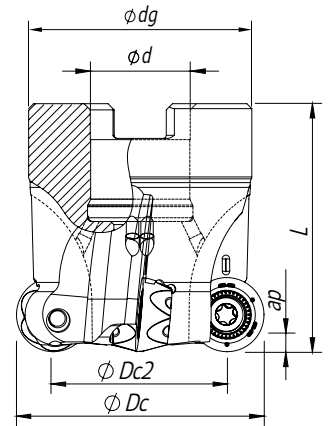

Arbor Mounting

$$\gamma_p = 5^\circ$$

Order code Código	Reference Referência Referencia		Dimensions Dimensões Dimensiones (mm)					Kg	Specifications		Insert	Stock
			ϕDc	$\phi Dc2$	ϕd	ϕdg	L		Arbor Type	A_p max (mm)		
181159600	040A34290-04-05-016040		40	28	16	36	40	0,15	A	6	RPHT 1204 M0E-LS(4)	
181159500	052A34290-05-05-022040		52	40	22	42	40	0,25	A	6	RPHT 1204 M0E-LS(4)	
181160400	063A34290-06-05-022040		63	51	22	48	40	0,36	A	6	RPHT 1204 M0E-LS(4)	
181160500	066A34290-06-05-027050		66	54	27	48	50	0,40	A	6	RPHT 1204 M0E-LS(4)	
181160600	080A34290-07-05-027050		80	68	27	60	50	0,68	A	6	RPHT 1204 M0E-LS(4)	

Stock item | Produto de stock | Itens de stock

Available under request (see page A-8) | Disponível sobre consulta (consulte a página A-8) | Disponible bajo consulta (mire página A-8)

SPARE PARTS Complementos | Repuestos

Cutter ØDc	Insert Screw	Key (Torx)	Order separately	
			Key (Torx - Nm)	Torque Value
34190	P0300800	XT09	DT0914	1,40
34290	P0350800	XT15	DT1530	3,00

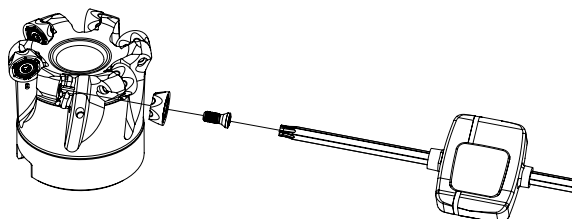

Note: The toolholder is supplied with the XT/PT key. To order the DT key please check the page A-241.
Check the procedures for the clamping screws on the page A-241.

RPHT-LS | Inserts | Pastilhas | Plaquitas

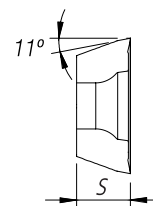
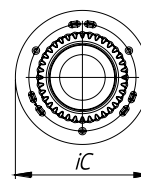
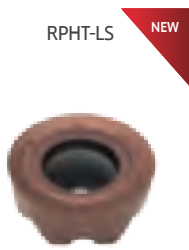
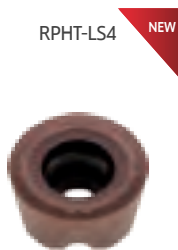

Geometry code	ISO Reference	P			M			S		Dimensions Dimensões Dimensiones (mm)	
		CVD	PVD		PVD			PVD		iC	S
(1)	(2) Grade code	T9	Z1	Z2	Y2	Z2	Z3	Y2	Z3		
1112772	RPHT 10T3M0E-LS	⊗	⊗	⊗	⊗	⊗	⊗	⊗	⊗	10,00	3,97
1113021	RPHT 10T3 M0E-LS4			⊗		⊗	⊗		⊗	10,00	3,97
1112766	RPHT 1204 M0E-LS	⊗	⊗	⊗	⊗	⊗	⊗	⊗	⊗	12,00	4,76
1113020	RPHT 1204 M0E-LS4			⊗		⊗	⊗		⊗	12,00	4,76

⊗ First choice | Primeira opção | 1ª opción ⊗ Stock item | Produto de stock | Itens de stock

○ Available under request (see page A-9) | Disponível sobre consulta (consulte a página A-9) | Disponible bajo consulta (mire página A-9)

Insert order code = (1) Geometry Code + (2) Grade Code



GRADES SELECTION GUIDE | Guia para selecção de graus | Tabla para selección de calidades

ISO	PSM	Material	HB (Brinell)	Grades						
				← Wear Resistance				Toughness →		
				PHP920	PHH930	PHP530	PHH530	PHP808	PHH808	PHS740
P	1	Unalloyed Steel	125-220	✓	⊙	✓	⊙	✓	⊙	✓
	2	Low-Alloyed Steel	220-280	✓	⊙	✓	⊙	✓	⊙	✓
	3	High-Alloyed Steel	280-380	✓	⊙	✓	⊙	✓	⊙	✓
M	4	SS - Ferritic / Martensitic	200-330		✓	✓	✓		✓	
	5	SS - Austenitic	200-330		✓		✓		✓	
	6	SS - Austenitic-ferritic (Duplex)	230-260		✓		✓		✓	
S	11	Heat Resistant Super Alloys	200-320		✓		✓		✓	

⊙ Good Conditions

⊙ Average Conditions

⊙ Difficult Conditions

RECOMMENDED CUTTING CONDITIONS | Condições de corte recomendadas | Condiciones de corte recomendables

ISO	PSM	Material	HB (Brinell)	Vc (m/min)						
				← Wear Resistance				Toughness →		
				PHP920	PHH930	PHP530	PHH530	PHP808	PHH808	PHS740
P	1	Unalloyed Steel	125-220	180-250	-	180-340	-	180-340	-	180-350
	2	Low-Alloyed Steel	220-280	160-230	-	180-340	-	180-340	-	180-340
	3	High-Alloyed Steel	280-380	140-220	-	180-330	-	180-330	-	180-340
M	4	SS - Ferritic / Martensitic	200-330	-	140-210	150-270	170-280	-	160-270	-
	5	SS - Austenitic	200-330	-	120-170	-	160-280	-	160-270	-
	6	SS - Austenitic-ferritic (Duplex)	230-260	-	100-150	-	150-260	-	150-250	-
S	11	Heat Resistant Super Alloys	200-320	-	30-110	-	30-150	-	30-140	-

ISO	PSM	Material	HB (Brinell)	Feed fz (mm/t)				
				RDHT 08..	RPHT 10...	RPHT 12...	RPHT 16...	RPHT 20...
P	1	Unalloyed Steel	125-220	0,05-0,35	0,05-0,40	0,05-0,45	0,08-0,55	0,10-0,55
	2	Low-Alloyed Steel	220-280	0,05-0,35	0,05-0,40	0,05-0,45	0,08-0,55	0,10-0,55
	3	High-Alloyed Steel	280-380	0,05-0,30	0,05-0,35	0,05-0,40	0,08-0,50	0,10-0,55
M	4	SS - Ferritic / Martensitic	200-330	0,05-0,25	0,05-0,30	0,05-0,35	0,08-0,45	0,10-0,50
	5	SS - Austenitic	200-330	0,05-0,25	0,05-0,30	0,05-0,35	0,08-0,45	0,10-0,50
	6	SS - Austenitic-ferritic (Duplex)	230-260	0,05-0,25	0,05-0,30	0,05-0,35	0,08-0,45	0,10-0,45
S	11	Heat Resistant Super Alloys	200-320	0,05-0,20	0,05-0,25	0,05-0,30	0,08-0,35	0,10-0,40

(Note 1) Cutting conditions $a_e/D_c=70\%$.

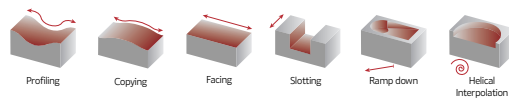

INSERT INFORMATION | Informação de pastilha | Información del inserto

RPHT-LS

RPHT-LS

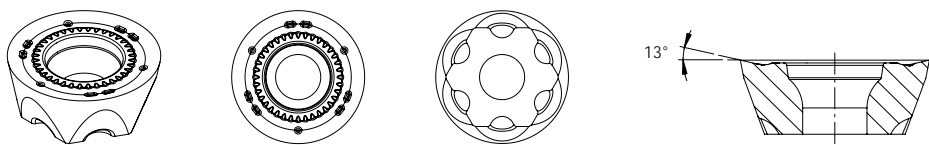

P M S

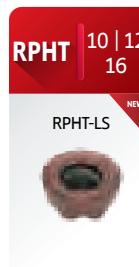

6 cutting edges insert

- Insert with 6 cutting edges for a higher productivity.

Insert Geometry

- Improved geometry for low cutting force;
- Positive insert with a brand new edge positioning system.

The maximum depth of cut using 6 cutting edges (LS)

TOROMILL 33590

RDHT 0802...

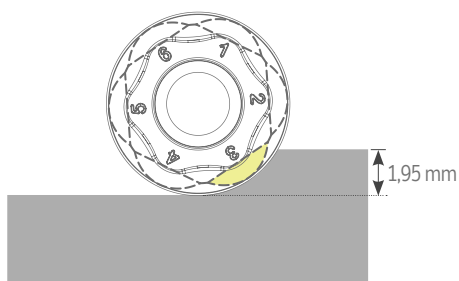

TURBOMILL 34190

RPHT 10T3M0E-LS

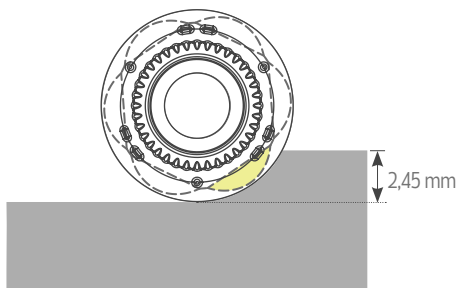

TURBOMILL 34290

RPHT 1204 M0E-LS

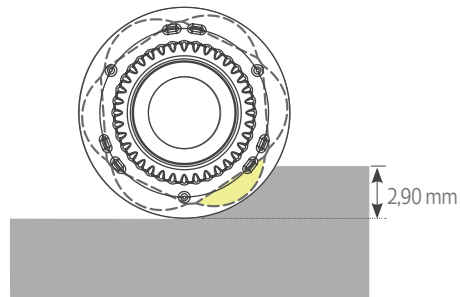

TOROMILL 33890

RPHT 1605 M0E-LS

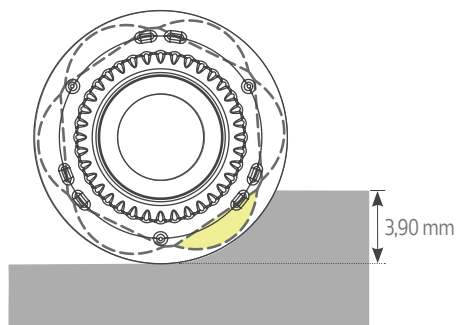

TOROMILL 33990

RPHT 2006...

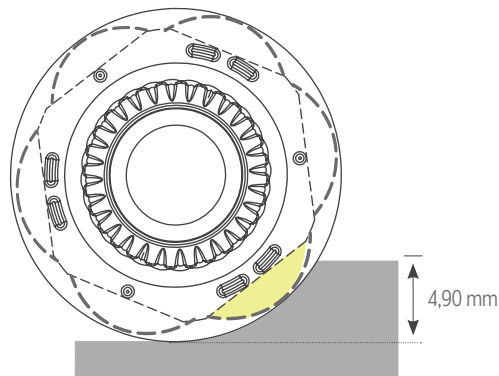

RPHT-LS4

RPHT-LS4

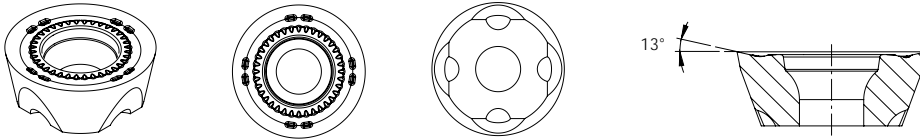

P M S

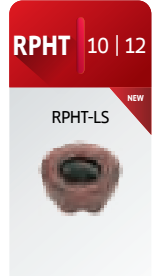

4 cutting edges insert

- Insert with 4 cutting edges for higher depth of cut.

Insert Geometry

- Improved geometry for low cutting force;
- Positive insert with a brand new edge positioning system.

The maximum depth of cut using 4 cutting edges

TURBOMILL 34190

RPHT 10T3M0E-LS4

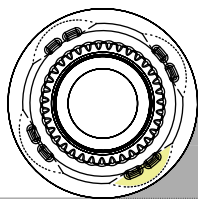

4,90 mm

TURBOMILL 34290

RPHT 1204 M0E-LS4

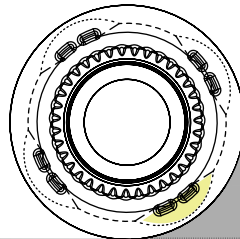

5,90 mm

GEOMETRY FEATURES | Características geométricas | Características geométricas

Geometry	Features Características Características
Geometry LS General machining	Optimized geometry for stainless steel and HRSA. Suitable for alloy steel machining.
Geometry LS4 General machining	Optimized geometry for stainless steel and HRSA. Suitable for alloy steel machining. 4 Cutting edges version.

RAMPING AND HELICAL INTERPOLATION

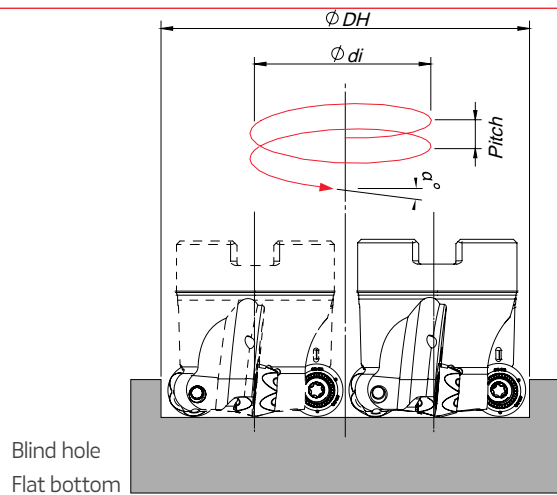
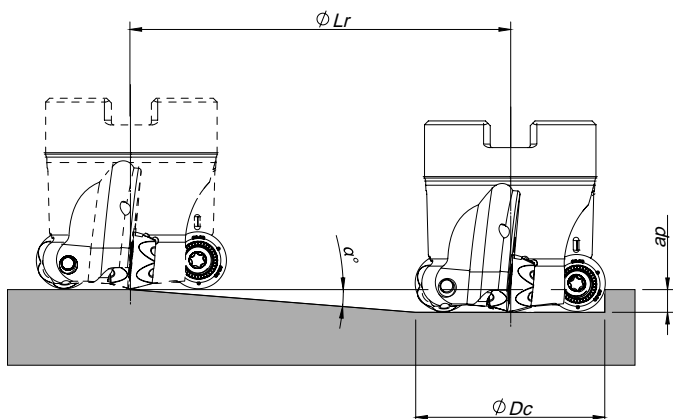

$$\phi di = \phi DH - \phi Dc$$

Insert	ϕDc	Ramping			Helical Interpolation		
		Max Ramp α°	Max ap	Min Lr	ϕDH_{min}	ϕDH_{max}	Max Pitch/Rev.
33590							
RD... 08	16	10,0	4,0	22,7	24 -	- 32	4 8
	20	8,0	4,0	28,5	32 -	- 40	5 8
	25	10,0	4,0	22,7	42 -	- 50	9 13
	32	8,0	4,0	28,5	56 -	- 64	10 14
33690 34190							
RP... 10	20	7,0	5,0	40,7	30 -	- 40	3 7
	25	6,0	5,0	47,6	40 -	- 50	4 8
	32	6,0	5,0	47,6	54 -	- 64	7 10
	35	5,0	5,0	57,2	60 -	- 70	6 9
	42	5,0	5,0	57,2	74 -	- 84	8 11
	50	4,0	5,0	71,5	90 -	- 100	8 10
	52	3,0	5,0	95,4	94 -	- 104	6 8
34290							
RP... 12	40	8,0	6,0	42,7	68 -	- 80	12 17
	50	3,5	6,0	98,1	88 -	- 100	7 9
	52	3,0	6,0	114,5	92 -	- 104	6 8
	63	2,5	6,0	137,4	114 -	- 126	6 8
	66	2,5	6,0	137,4	120 -	- 132	7 9
	80	2,0	6,0	171,8	148 -	- 160	7 8
33890							
RP... 16	50	7,0	8,0	65,2	84 -	- 100	13 19
	52	7,0	8,0	65,2	88 -	- 104	13 20
	63	7,0	8,0	65,2	110 -	- 126	18 24
	66	3,0	8,0	152,6	116 -	- 132	8 10
	80	3,0	8,0	152,6	144 -	- 160	10 13
	100	3,0	8,0	152,6	184 -	- 200	13 16
	125	2,5	8,0	183,2	234 -	- 250	14 17
33990							
RP... 20	80	4,0	10,0	143,0	140 -	- 160	13 17
	100	3,0	10,0	190,8	180 -	- 200	13 16
	125	2,5	10,0	229,0	230 -	- 250	14 17

Note: During helical interpolation do not exceed max Pitch.

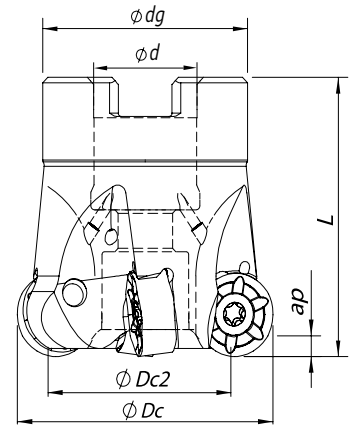
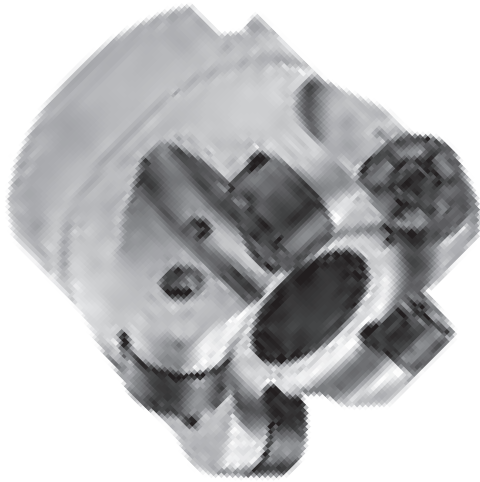

Arbor Mounting

$$\gamma_p = -7^\circ$$

Order code Código	Reference Referência Referencia		Dimensions Dimensões Dimensiones (mm)					Kg	Specifications		Insert Pastilha Inserto	Stock
			ϕDc	$\phi Dc2$	ϕd	ϕdg	L		Arbor Type	Ap max (mm)		
181111600	040A35190-04-07-016040	4	40	32	16	32	40	0,20	A	3,0	RNHX 1204 MOE...	
181100200	050A35190-05-07-022040	5	50	42	22	40	40	0,24	A	3,0	RNHX 1204 MOE...	
181128800	063A35190-06-07-022050	6	63	49	22	48	50	0,55	A	3,0	RNHX 1204 MOE...	
181128900	080A35190-07-07-027050	7	80	60	27	60	50	0,78	A	3,0	RNHX 1204 MOE...	
181175600	100A35190-09-07-032050	9	100	80	32	70	50	1,00	B	3,0	RNHX 1204 MOE...	

Stock item | Produto de stock | Itens de stock

Available under request (see page A-8) | Disponível sobre consulta (consulte a página A-8) | Disponible bajo consulta (mire pagina A-8)

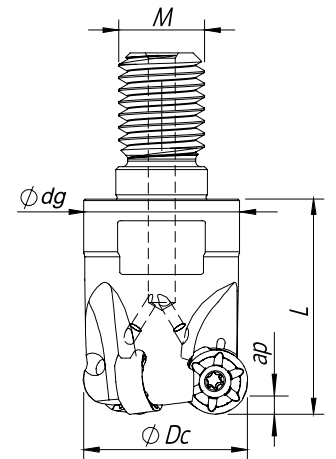

Threaded Coupling

$$\gamma_p = -7^\circ$$

Order code Código	Reference Referência Referencia		Dimensions Dimensões Dimensiones (mm)				Kg	Specifications		Insert Pastilha Inserto	Stock
			ϕDc	ϕM	ϕdg	L		Ap max (mm)			
181128500	032R35190-03-07-M16040	3	32	M16	29	40	0,16	3,0	RNHX 1204 MOE...		
181128700	042R35190-04-07-M16040	4	42	M16	29	40	0,20	3,0	RNHX 1204 MOE...		

Stock item | Produto de stock | Itens de stock

Available under request (see page A-8) | Disponível sobre consulta (consulte a página A-8) | Disponible bajo consulta (mire pagina A-8)

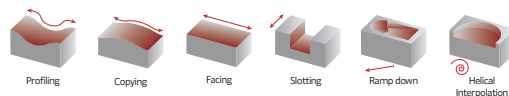

Weldon Shank

$$\gamma_p = -7^\circ$$

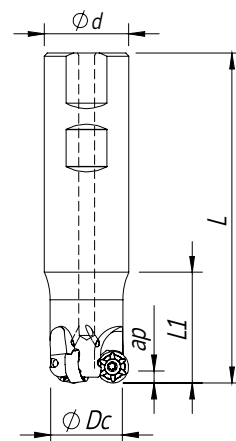

Order code Código	Reference Referência Referencia		Dimensions Dimensões Dimensiones (mm)				Kg	Specifications	Insert Pastilha Inserto	Stock
			ØDc	Ød/M	L	L1		Ap max (mm)		
181087000	032W35190-03-07-032125	3	32	32	125	42	0,98	3,0	RNHX 1204 MOE...	

Stock item | Produto de stock | Itens de stock

Available under request (see page A-9) | Disponível sobre consulta (consulte a página A-9) | Disponible bajo consulta (mire pagina A-9)

RNHX 1204... | Inserts | Pastilhas | Plaquetas

RNHX-LP



RNHX-MP



RNHX-LP | MP

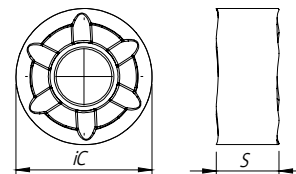

Geometry code (1)	ISO Reference	P			M			K		S		Dimensions Dimensões Dimensiones (mm)	
		PVD			PVD			PVD		PVD		IC	S
		T1	P4	Z2	X9	Z2	Z3	T1	P4	X9	Z3		
1112030	RNHX 1204 MOE-LP											12,00	4,76
1112052	RNHX 1204 MOE-MP											12,00	4,76

First choice | Primeira opção | 1ª opción

Stock item | Produto de stock | Itens de stock

Available under request (see page A-9) | Disponível sobre consulta (consulte a página A-9) | Disponible bajo consulta (mire pagina A-9)

Insert order code = (1) Geometry Code + (2) Grade Code

TOROMILL X2 35190

SPARE PARTS | Complementos | Repuestos

Cutter ØDc	Insert Screw	Key (Torx)	Order separately	
			Key (Torx - Nm)	Torque Value
35190	P0401065	XT15	DT1530	3,00

Note: The toolholder is supplied with the XT/PT key. To order the DT key please check the page A-241.
Check the procedures for the clamping screws on the page A-241.

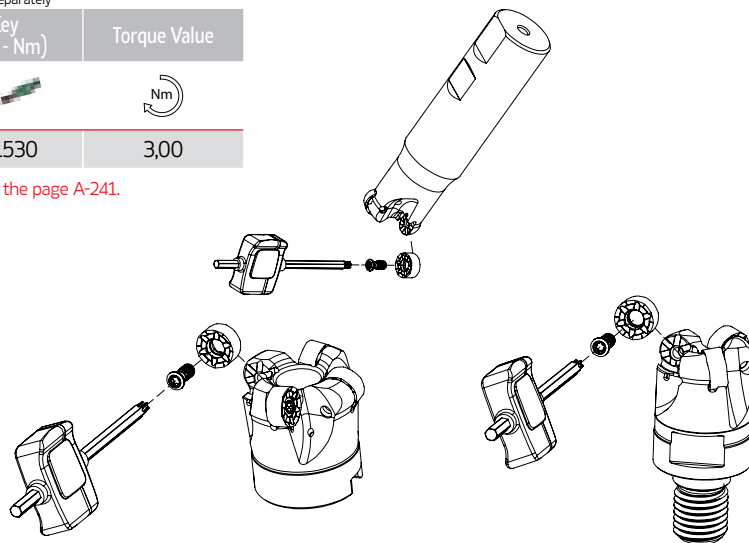

GRADES SELECTION GUIDE | Guia para selecção de graus | Tabla para selección de calidades

ISO	PSM	Material	HB (Brinell)	Grades				
				← Wear Resistance			Toughness →	
				PHP920	PHP930	PHH930	PHP530	PHH530
P	1	Unalloyed Steel	125-220	✓	✓		✓	
	2	Low-Alloyed Steel	220-280	✓	✓		✓	
	3	High-Alloyed Steel	280-380	✓	✓		✓	
M	4	SS - Ferritic / Martensitic	200-330			✓	✓	
	5	SS - Austenitic	200-330			✓		✓
	6	SS - Austenitic-ferritic (Duplex)	230-260			✓		✓
K	7	Malleable Cast Iron	130-230	✓	✓			
	8	Grey Cast Iron	180-245	✓	✓			
	9	Nodular Cast iron	160-250	✓	✓			
S	11	Heat Resistant Super Alloys	200-320			✓		✓

● Good Conditions

● Average Conditions

● Difficult Conditions

RECOMMENDED CUTTING CONDITIONS | Condições de corte recomendadas | Condiciones de corte recomendables

ISO	PSM	Material	HB (Brinell)	Vc (m/min)					Feed fz (mm/t)	
				← Wear Resistance			Toughness →		RNHX 12... LP	RNHX 12... MP
				PHP920	PHP930	PHH930	PHP530	PHH530		
P	1	Unalloyed Steel	125-220	180-250	160-230	-	180-340	-	0,15-0,45	0,15-0,50
	2	Low-Alloyed Steel	220-280	160-230	140-210	-	180-340	-	0,15-0,45	0,15-0,50
	3	High-Alloyed Steel	280-380	140-220	120-200	-	180-330	-	0,15-0,45	0,15-0,45
M	4	SS - Ferritic / Martensitic	200-330	-	-	140-210	150-270	170-280	0,10-0,35	-
	5	SS - Austenitic	200-330	-	-	120-170	-	160-280	0,10-0,35	-
	6	SS - Austenitic-ferritic (Duplex)	230-260	-	-	100-150	-	150-260	0,10-0,35	-
K	7	Malleable Cast Iron	130-230	-	150-280	-	-	-	-	0,15-0,55
	8	Grey Cast Iron	180-245	-	130-230	-	-	-	-	0,15-0,55
	9	Nodular Cast iron	160-250	-	80-190	-	-	-	-	0,15-0,50
S	11	Heat Resistant Super Alloys	200-320	-	-	30-110	-	30-150	0,05-0,30	-

CHIP-BREAKER SELECTION GUIDE | Guia para aplicações do quebra-afaras | Guía para aplicación del rompevirutas

ISO	PSM	Material	HB (Brinell)	Chip-Breaker Application	
				1st choice	Difficult Operations
P	1	Unalloyed Steel	125-220	LP	MP
	2	Low-Alloyed Steel	220-280	LP	MP
	3	High-Alloyed Steel	280-380	MP	-
M	4	SS - Ferritic / Martensitic	200-330	LP	-
	5	SS - Austenitic	200-330	LP	-
	6	SS - Austenitic-ferritic (Duplex)	230-260	LP	-
K	7	Malleable Cast Iron	130-230	MP	-
	8	Grey Cast Iron	180-245	MP	-
	9	Nodular Cast iron	160-250	MP	-
S	11	Heat Resistant Super Alloys	200-320	LP	-

RAMPING | Descida em rampa | Bajada en rampa

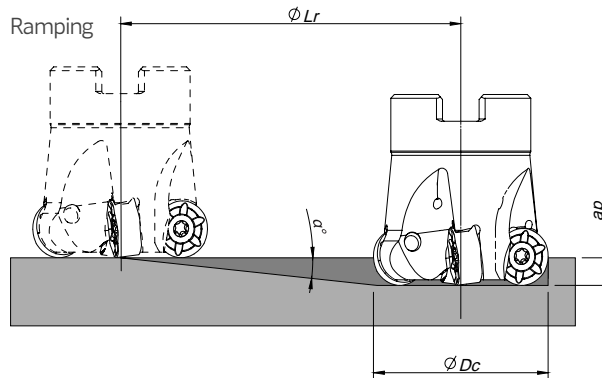

Insert	$\varnothing Dc$	Ramping		
		Max Ramp a°	Max ap	Min Lr
RNHX 1204	32	1	3	171,9
	40	0,8	3	214,8
	42	0,8	3	214,8
	50	0,8	3	214,8
	63	0,6	3	286,5
	80	0,5	3	343,8



TOROMILL 24590 | 25090 | 25190

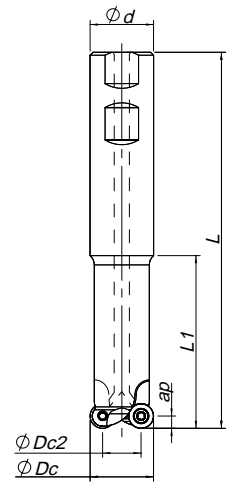

Weldon Shank

$$\gamma_p = 0^\circ$$

Order code Código	Reference Referência Referencia		Dimensions Dimensões Dimensiones (mm)							Kg	Specifications	Insert Pastilha Inserto	Stock	
			ϕDc	$\phi Dc2$	ϕd	ϕdg	L	L1	L2		A_p max (mm)			
24590														
181047000	015W24590-02-U016160		2	15	8	16	-	160	60	40	0,220	3,5	RD... 0702...	
181047100	015W24590-02-U025220		2	15	8	25	-	220	120	40	0,600	3,5	RD... 0702...	
25090														
181047200	020W25090-02-020160		2	20	10	20	-	160	60	-	0,322	5,0	RD... 1003...	
181047300	020W25090-02-025220		2	20	10	25	-	220	120	60	0,610	5,0	RD... 1003...	
25190														
181047400	025W25190-02-025220		2	25	13	25	-	220	120	-	0,678	6,0	RD... 12T3...	
181047500	025W25190-02-032230		2	25	13	32	-	230	130	80	1,015	6,0	RD... 12T3...	

Stock item | Produto de stock | Itens de stock

Available under request (see page A-8) | Disponível sobre consulta (consulte a página A-8) | Disponible bajo consulta (mire página A-8)

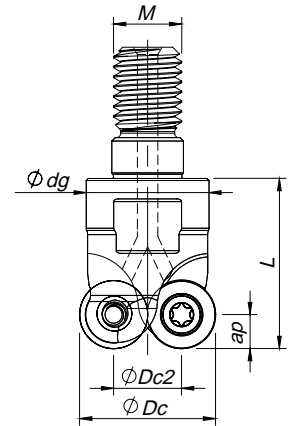

Threaded Coupling

$$\gamma_p = 0^\circ$$

Order code Código	Reference Referência Referencia		Dimensions Dimensões Dimensiones (mm)						Kg	Specifications	Insert Pastilha Inserto	Stock
			ϕDc	$\phi Dc2$	ϕM	ϕdg	L	A_p max (mm)				
24590												
181015400	015R24590-03-M08020		3	15	8	M8	13	20	0,019	3,5	RD... 0702...	
181019100	016R24590-02-M08020		2	16	9	M8	13	20	0,019	3,5	RD... 0702...	
181037900	016R24590-03-M08020		3	16	9	M8	13	20	0,019	3,5	RD... 0702...	
181011400	020R24590-04-M10025		4	20	13	M10	18	25	0,047	3,5	RD... 0702...	
25090												
181011500	020R25090-02-M10025		2	20	10	M10	18	25	0,041	5,0	RD... 1003...	
181011600	025R25090-03-M12030		3	25	15	M12	21	30	0,075	5,0	RD... 1003...	
181011700	030R25090-04-M16035		4	30	20	M16	29	35	0,190	5,0	RD... 1003...	
181015500	035R25090-05-M16043		5	35	25	M16	29	43	0,240	5,0	RD... 1003...	
181049900	042R25090-05-M16040		5	42	32	M16	29	40	0,243	5,0	RD... 1003...	
25190												
181011800	024R25190-02-M12032		2	24	12	M12	21	32	0,072	6,0	RD... 12T3...	
181011900	035R25190-03-M16042		3	35	23	M16	29	42	0,205	6,0	RD... 12T3...	
181012000	042R25190-04-M16042		4	42	30	M16	29	42	0,232	6,0	RD... 12T3...	

Stock item | Produto de stock | Itens de stock

Available under request (see page A-8) | Disponível sobre consulta (consulte a página A-8) | Disponible bajo consulta (mire página A-8)



Arbor Mounting

$\gamma_p = 0^\circ (*+7^\circ)$

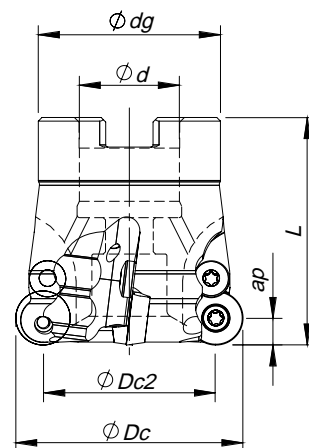

Order code Código	Reference Referência Referencia		Dimensions Dimensões Dimensiones (mm)					Kg	Specifications		Insert Pastilha Inserto	Stock
			ϕDc	$\phi Dc2$	ϕd	ϕdg	L		Arbor Type	Ap max (mm)		
25090												
181010600	042A25090-06-016044	6	42	32	16	36	44	0,254	A	5,0	RD... 1003...	
181017500	052A25090-07-022050	7	52	42	22	40	50	0,395	A	5,0	RD... 1003...	
25190												
181051900	050C25190-05-07-022050*	5	50	38	22	40	50	0,312	A	6,0	RD... 12T3...	
181010700	052C25190-05-022050	5	52	40	22	40	50	0,337	A	6,0	RD... 12T3...	
181010800	052C25190-05-07-022050*	5	52	40	22	40	50	0,335	A	6,0	RD... 12T3...	
181016100	066C25190-06-027050	6	66	54	27	48	50	0,550	A	6,0	RD... 12T3...	
181010900	066C25190-06-07-027050*	6	66	54	27	48	50	0,600	A	6,0	RD... 12T3...	
181016500	080C25190-07-027050	7	80	68	27	60	50	1,000	A	6,0	RD... 12T3...	
181016600	080C25190-07-07-027052*	7	80	68	27	60	52,5	1,000	A	6,0	RD... 12T3...	

Stock item | Produto de stock | Itens de stock

Available under request (see page A-8) | Disponível sobre consulta (consulte a página A-8) | Disponible bajo consulta (mire pagina A-8)

SPARE PARTS | Complementos | Repuestos

Cutter ϕDc	Insert Screw	Key (Torx)	Order separately		Screw Clamp
			Key (Torx - Nm)	Torque Value	
W24590 - 15	P0250503	XT08	DT0812	1,2	-
R24590 - 15-20	P0250503	XT08	DT0812	1,2	-
W25090 - 20	P0350800	XT15	DT1530	3,0	-
R25090 - 20-42	P0350800	XT15	DT1530	3,0	-
A25090 - 42-52	P0350800	XT15	DT1530	3,0	-
W25190 - 25	P0350800	XT15	DT1530	3,0	-
R25190 - 24-42	P0350800	XT15	DT1530	3,0	-
C25190 - 50-80	P0350800	XT15	DT1530	3,0	P0350750

Note: The toolholder is supplied with the XT/PT key. To order the DT key please check the page A-241.
Check the procedures for the clamping screws on the page A-241.

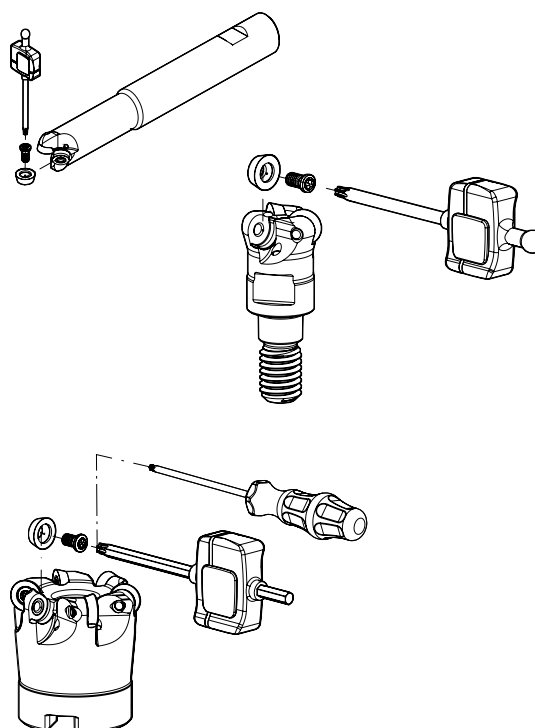

TOROMILL 25290 | 25390

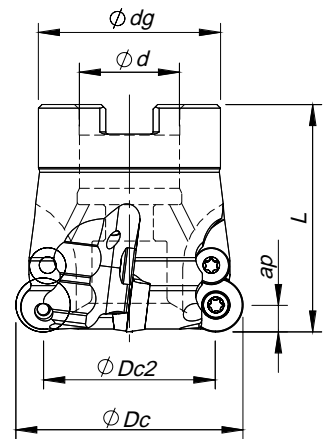

Arbor Mounting

$$\gamma_p = 0^\circ (*+7^\circ)$$

Order code Código	Reference Referência Referencia		Dimensions Dimensões Dimensiones (mm)					Kg	Specifications		Insert Pastilha Inserto	Stock
			ϕDc	$\phi Dc2$	ϕd	ϕdg	L		Arbor Type	Ap max (mm)		
25290												
181017900	052C25290-04-022050	4	52	36	22	40	50	0,305	A	8,0	RD... 1604...	
181018000	052C25290-04-07-022050*	4	52	36	22	40	50	0,324	A	8,0	RD... 1604...	
181011000	066C25290-05-027050	5	66	50	27	48	50	0,550	A	8,0	RD... 1604...	
181016700	066C25290-05-07-027050*	5	66	50	27	48	50	0,550	A	8,0	RD... 1604...	
181016200	080C25290-06-027052	6	80	64	27	60	52	0,910	A	8,0	RD... 1604...	
181011100	080C25290-06-07-027052*	6	80	64	27	60	52	0,934	A	8,0	RD... 1604...	
181017300	125C25290-08-07-U040052*	8	125	109	40	90	52	2,340	B	8,0	RD... 1604...	
181017400	160C25290-09-07-U040052*	9	160	144	40	120	52	4,750	B	8,0	RD... 1604...	
25390												
181026400	080C25390-05-07-027050*	5	80	60	27	60	50	0,840	A	10,0	RD... 2006...	
181016800	100C25390-06-07-U032052*	6	100	80	32	70	52	1,180	B	10,0	RD... 2006...	
181020500	125C25390-07-07-U040052*	7	125	105	40	90	52	2,030	B	10,0	RD... 2006...	
181020600	160C25390-08-07-U040052*	8	160	140	40	120	52	4,320	B	10,0	RD... 2006...	

Stock item | Produto de stock | Itens de stock

Available under request (see page A-8) | Disponível sobre consulta (consulte a página A-8) | Disponible bajo consulta (mire pagina A-8)

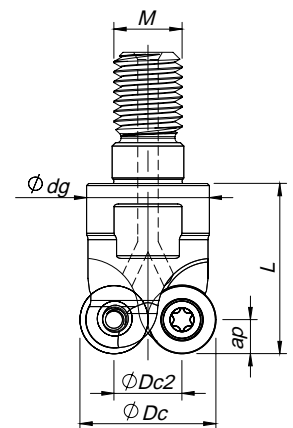
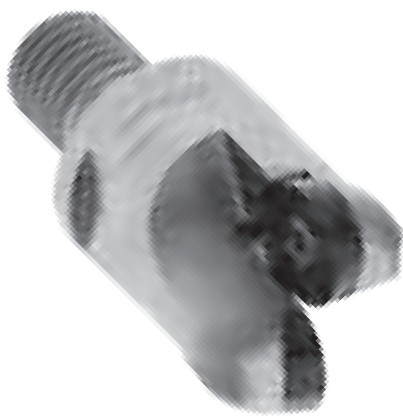

Threaded Coupling

$$\gamma_p = 0^\circ$$

Order code Código	Reference Referência Referencia		Dimensions Dimensões Dimensiones (mm)					Kg	Specifications		Insert Pastilha Inserto	Stock
			ϕDc	$\phi Dc2$	ϕM	ϕdg	L		Ap max (mm)			
25290												
181002600	032R25290-02-M16040	2	32	16	M16	29	40	0,162	8,0	RD... 1604...		
181034800	032R25290-03-M16042	3	35	19	M16	29	42	0,230	8,0	RD... 1604...		

Stock item | Produto de stock | Itens de stock

Available under request (see page A-8) | Disponível sobre consulta (consulte a página A-8) | Disponible bajo consulta (mire pagina A-8)



RD... || Inserts | Pastilhas | Plaquetas

RDHT

RDHW

RDMT

RDMW

RDHT | RDHW | RDMT | RDMW

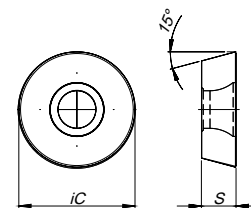

(1) Geometry code	(2) Grade code	P						K			H	Dimensions Dimensões Dimensiones (mm)	
		PVD						PVD			PVD		
		M6	54	68	78	86	I5	54	68	I5	M6	iC	S
1110548	RDHW 0702 M0T	⊗	⊗	⊗				⊗	⊗		⊗	7,00	2,38
1110087	RDHW 1003 M0T	⊗	⊗	⊗		⊗		⊗	⊗		⊗	10,00	3,18
1110082	RDHT 1003 M0T				⊗	⊗						10,00	3,18
1110583	RDMT 1003 M0T				⊗	⊗						10,00	3,18
1110549	RDMW 1003 M0T			⊗	⊗	⊗						10,00	3,18
1110090	RDHW 12T3 M0T	⊗	⊗	⊗		⊗		⊗	⊗		⊗	10,00	3,18
1112040	RDHT 12T3 M0S-MP			⊗			⊗		⊗	⊗		10,00	3,18
1110083	RDHT 12T3 M0T				⊗	⊗						12,00	3,97
1110558	RDMT 12T3 M0T				⊗	⊗						12,00	3,97
1110096	RDMW 12T3 M0T			⊗	⊗	⊗			⊗			12,00	3,97
1110092	RDHW 1604 M0T	⊗	⊗	⊗		⊗		⊗	⊗		⊗	16,00	4,76
1112039	RDHT 1604 M0S-MP			⊗			⊗		⊗	⊗		16,00	4,76
1110084	RDHT 1604 M0T				⊗	⊗						16,00	4,76
1110556	RDMT 1604 M0T				⊗	⊗						16,00	4,76
1110097	RDMW 1604 M0T			⊗	⊗	⊗			⊗			16,00	4,76
1110869	RDMW 2006 M0T				⊗							20,00	6,35

⊗ First choice | Primeira opção | 1ª opción ⊗ Stock item | Produto de stock | Itens de stock ○ Available under request (see page A-9) | Disponível sobre consulta (consulte a página A-9) | Disponible bajo consulta (mire página A-9) Insert order code = (1) Geometry Code + (2) Grade Code

A

MILLING

Overview

Face milling

Hi-feed milling

Shoulder milling

Profile milling

Hardmill

Center & Chamfer

Spot face

Spare Parts

Technical Data

End Mills

TOROMILL 24590 | 25090 | 25190 | 25290 | 25390

SPARE PARTS | Complementos | Repuestos

Cutter ØDc	Insert Screw	Key (Torx)	Order separately		Order separately		
			Key (Torx - Nm)	Torque Value	Screw Clamp	Washer	Washer Screw
W24590 - 15	P0250503	XT08	DT0812	1,2	-	-	-
R24590 - 15-20	P0250503	XT08	DT0812	1,2	-	-	-
W25090 - 20	P0350800	XT15	DT1530	3,0	-	-	-
R25090 - 20-42	P0350800	XT15	DT1530	3,0	-	-	-
A25090 - 42-52	P0350800	XT15	DT1530	3,0	-	-	-
W25190 - 25	P0350800	XT15	DT1530	3,0	-	-	-
R25190 - 24-42	P0350800	XT15	DT1530	3,0	-	-	-
C25190 - 50-80	P0350800	XT15	DT1530	3,0	P0350750	-	-
R25290 - 32-35	P0451001	XT20	DT2050	5,0	-	-	-
C25290 - 52-80	P0451001	XT20	DT2050	5,0	-	HC01200	P0451001
C25290 - 125-160	P0451001	XT20	DT2050	5,0	-	HC01200	P0451001
C25390 - 80-160	P0601402	TT20	-	10,0	-	HC01200	P0451001

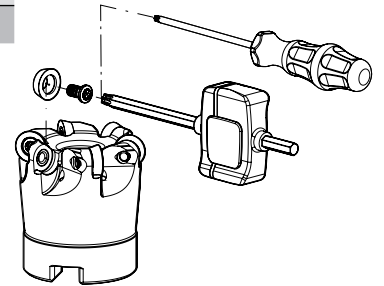
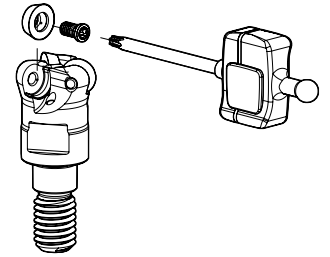
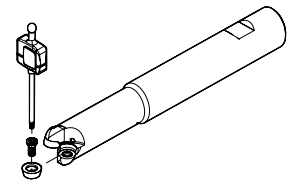

Note: The toolholder is supplied with the XT/PT key. To order the DT key please check the page A-241.
Check the procedures for the clamping screws on the page A-241.

GRADES SELECTION GUIDE | Guia para selección de graus | Tabla para selección de calidades

ISO	PSM	Material	HB (Brinell)	Grades					
				← Wear Resistance			Toughness →		
				PH6103	PH6910	PH6920	PH6125	PH6135	PH6740
P	1	Unalloyed Steel	125-220	●	●	●	●	●	●
	2	Low-Alloyed Steel	220-280	●	●	●	●	●	●
	3	High-Alloyed Steel	280-380	●	●	●	●	●	●
K	7	Malleable Cast Iron	130-230	●	●	●	●	●	●
	8	Grey Cast Iron	180-245	●	●	●	●	●	●
	9	Nodular Cast iron	160-250	●	●	●	●	●	●
H	12	Hardened Steels	40-55 HRC	●	●	●	●	●	●

- Good Conditions
- Average Conditions
- Difficult Conditions

CHIP-BREAKER SELECTION GUIDE | Guia para aplicações do quebra- aparas | Guía para aplicación del rompevirutas

ISO	PSM	Material	HB (Brinell)	Chip-Breaker Application	
				1st choise	Dificult Operations
P	1	Unalloyed Steel	125-220	RD...T ...	RD...W ...
	2	Low-Alloyed Steel	220-280	RD...T ...	-
	3	High-Alloyed Steel	280-380	RD...W ...	-
K	7	Malleable Cast Iron	130-230	RD...T ...	RD...W ...
	8	Grey Cast Iron	180-245	RD...W ...	-
	9	Nodular Cast iron	160-250	RD...W ...	-
H	12	Hardened Steels	40-55 HRC	RD...W ...	-

A

MILLING

Overview

Face milling

Hifeed milling

Shoulder milling

Profile milling

Hardmill

Center & Chamfer

Spot face

Spare Parts

Technical Data

End Mills

TOROMILL 24590 | 25090 | 25190 | 25290 | 25390

RECOMMENDED CUTTING CONDITIONS | Condições de corte recomendadas | Condiciones de corte recomendables

ISO	PSM	Material	HB (Brinell)	Vc (m/min)					
				← Wear Resistance				Toughness →	
				PH6103	PH6910	PH6920	PH6125	PH6135	PH6740
P	1	Unalloyed Steel	125-220	180-300	180-250	150-230	160-190	150-180	130-160
	2	Low-Alloyed Steel	220-280	180-250	170-210	140-220	140-180	140-170	120-150
	3	High-Alloyed Steel	280-380	180-230	160-200	130-180	130-160	120-150	100-130
K	7	Malleable Cast Iron	130-230	-	170-300	150-280	-	-	130-250
	8	Grey Cast Iron	180-245	-	150-250	130-230	-	-	110-220
	9	Nodular Cast iron	160-250	-	90-210	80-190	-	-	80-170
H	12	Hardened Steels	40-55 HRC	120-240	-	-	-	-	-

ISO	PSM	Material	HB (Brinell)	RD... 07		RD... 10		RD... 12	
				fz (mm/t)	ap (mm)	fz (mm/t)	ap (mm)	fz (mm/t)	ap (mm)
				P	1	Unalloyed Steel	125-220	≤0,18	≤1,50
2	Low-Alloyed Steel	220-280	≤0,18		≤1,50	≤0,24	≤2,50	≤0,25	≤2,50
3	High-Alloyed Steel	280-380	≤0,15		≤1,50	≤0,21	≤2,50	≤0,20	≤2,50
K	7	Malleable Cast Iron	130-230	≤0,20	≤1,50	≤0,25	≤2,50	≤0,24	≤2,50
	8	Grey Cast Iron	180-245	≤0,20	≤1,50	≤0,25	≤2,50	≤0,24	≤2,50
	9	Nodular Cast iron	160-250	≤0,18	≤1,50	≤0,22	≤2,50	≤0,22	≤2,50
H	12	Hardened Steels	40-55 HRC	≤0,12	≤1,50	≤0,18	≤2,50	≤0,18	≤2,50

ISO	PSM	Material	HB (Brinell)	RD... 16		RD... 20	
				fz (mm/t)	ap (mm)	fz (mm/t)	ap (mm)
				P	1	Unalloyed Steel	125-220
2	Low-Alloyed Steel	220-280	≤0,33		≤3,50	≤0,33	≤5,00
3	High-Alloyed Steel	280-380	≤0,27		≤3,50	≤0,27	≤5,00
K	7	Malleable Cast Iron	130-230	≤0,35	≤3,50	≤0,35	≤5,00
	8	Grey Cast Iron	180-245	≤0,35	≤3,50	≤0,35	≤5,00
	9	Nodular Cast iron	160-250	≤0,32	≤3,50	≤0,32	≤5,00
H	12	Hardened Steels	40-55 HRC	≤0,25	≤3,50	≤0,20	≤5,00

(Note 1) Cutting conditions $a_e/D_c=70\%$.

(Note 2) Cutting conditions should be adjusted according to the machine and work rigidity.

(Note 3) It's possible to occur vibrations in certain cases. Please reduce depth of cut and / or reduce cutting conditions in following cases:

- When using long shank;
- When using long tool overhang with arbor type;
- When application has poor clamping rigidity or when using a low rigidity machine.

RAMPING AND HELICAL INTERPOLATION

Descida em rampa e interpolação helicoidal | Bajada en rampa e interpolación circular

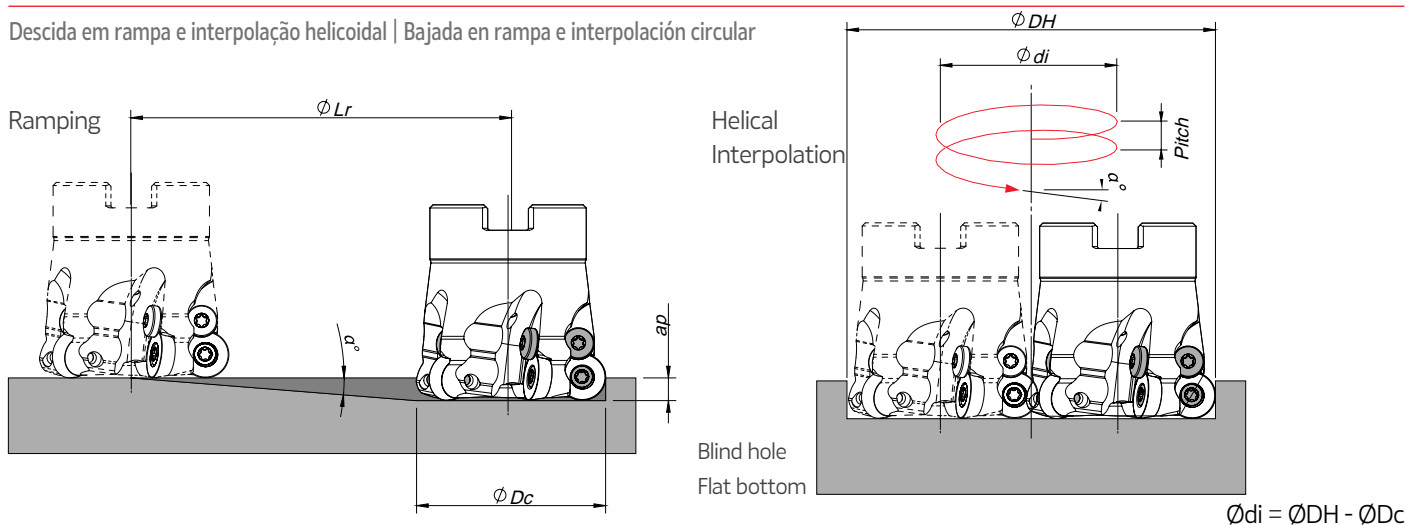

Insert	ϕ_{Dc}	Ramping			Helical Interpolation		
		Max Ramp α°	Max a_p	Min Lr	ϕ_{DHmin}	ϕ_{DHmax}	Max Pitch/Rev.
RD... 07	15	9,4	3,5	21,1	23,0	-	4,0
	16	8	3,5	24,9	25,0	30,0	7,0
	20	6	3,5	33,3	-	-	3,0
RD... 10	20	25,0	5,0	10,7	33,0	40,0	4,0
	25	22,0	5,0	12,4	-	-	6,0
	30	13,5	5,0	20,8	40,0	50,0	14,0
	35	12,0	5,0	23,5	50,0	60,0	29,0
	42	10,0	5,0	28,4	60,0	70,0	19,0
	52	7,0	5,0	40,7	74,0	84,0	15,0
RD... 12	24	17,0	6,0	19,6	94,0	104,0	23,0
	25	16,2	6,0	20,7	-	-	11,0
	35	12,0	6,0	28,2	36,0	48,0	23,0
	42	10,3	6,0	33,0	38,0	50,0	11,0
	50	6,4	6,0	53,5	58,0	70,0	15,0
	52	6,0	6,0	57,1	72,0	84,0	23,0
	66	3,5	6,0	79,8	88,0	100,0	13,0
	80	2,5	6,0	104,1	92,0	104,0	17,0
RD... 16	32	20,0	8,0	22,0	120,0	132,0	12,0
	35	18,0	8,0	24,6	-	-	15,0
	52	13,0	8,0	34,7	148,0	160,0	12,0
	66	8,5	8,0	53,5	-	-	14,0
	80	6,0	8,0	76,1	48,0	64,0	18,0
	125	3,5	8,0	130,8	54,0	70,0	36,0
	160	2,5	8,0	183,2	88,0	104,0	19,0
RD... 20	80	6,0	10,0	76,1	116,0	132,0	26,0
	100	5,0	10,0	91,4	-	-	37,0
	125	4,5	10,0	101,6	144,0	160,0	21,0
	160	3,0	10,0	152,6	180,0	200,0	26,0

Note: During helical interpolation do not exceed max Pitch.

LINEPRO 40095 | 40595 | 41095

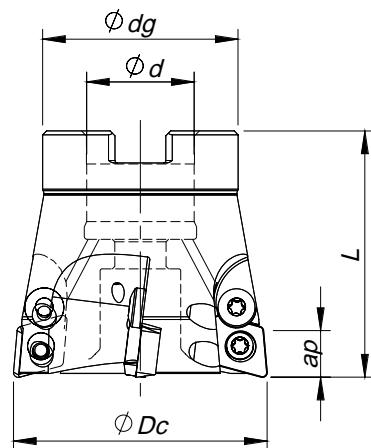
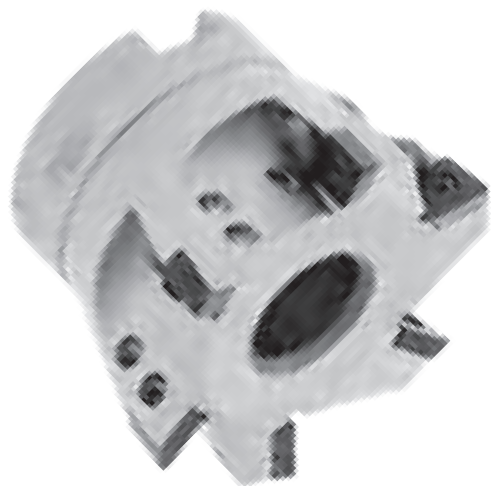

Arbor Mouting

$K_r=95^\circ$ | $\gamma_p=+7^\circ$

Order code Código	Reference Referência Referencia		Dimensions Dimensões Dimensiones (mm)				Kg	Specifications		Insert Pastilha Inserto	Stock
			ϕDc	ϕd	ϕdg	L		Arbor Type	Ap max (mm)		
40595											
181027700	052C40595-05-07-022050	5	52	22	40	50	0,342	A	1,0	XD... 10T3...	
181027800	066C40595-06-07-027050	6	66	27	48	50	0,565	A	1,0	XD... 10T3...	
181027900	080C40595-07-07-027050	7	80	27	60	50	0,972	A	1,0	XD... 10T3...	

Stock item | Produto de stock | Itens de stock

Available under request (see page A-8) | Disponível sobre consulta (consulte a página A-8) | Disponible bajo consulta (mire pagina A-8)

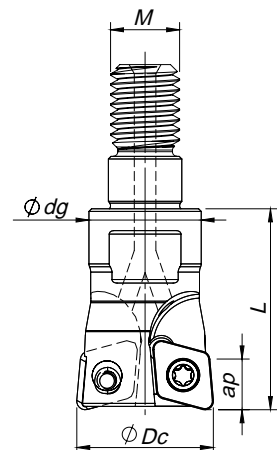

Threaded Coupling

$K_r=95^\circ$ | $\gamma_p=+7^\circ$ (*+9)

Order code Código	Reference Referência Referencia		Dimensions Dimensões Dimensiones (mm)				Kg	Specifications		Insert Pastilha Inserto	Stock
			ϕDc	ϕM	ϕdg	L		Ap max (mm)			
41095											
181012400	010R41095-02-09-M06020*	2	10	M6	9,8	20	0,010	0,8	XD... 0401...		
181016300	012R41095-02-09-M06020*	2	12	M6	9,8	20	0,012	0,8	XD... 0401...		
40095											
181012100	016R40095-02-07-M08023	2	16	M8	13	23	0,022	1,0	XD... 0602...		
181012200	020R40095-03-07-M10028	3	20	M10	18	28	0,050	1,0	XD... 0602...		
181015600	025R40095-03-07-M12030	3	25	M12	21	30	0,081	1,0	XD... 0602...		
181034000	025R40095-04-07-M12030	4	25	M12	21	30	0,078	1,0	XD... 0602...		
40595											
181015700	025R40595-02-07-M12035	2	25	M12	21	35	0,077	1,0	XD... 10T3...		
181012300	035R40595-03-07-M16043	3	35	M16	29	43	0,200	1,0	XD... 10T3...		
181016900	042R40595-04-07-M16043	4	42	M16	29	43	0,230	1,0	XD... 10T3...		

Stock item | Produto de stock | Itens de stock

Available under request (see page A-8) | Disponível sobre consulta (consulte a página A-8) | Disponible bajo consulta (mire pagina A-8)

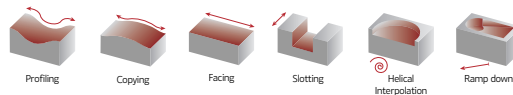

XDHW | Inserts | Pastilhas | Plaquetas

XDHW

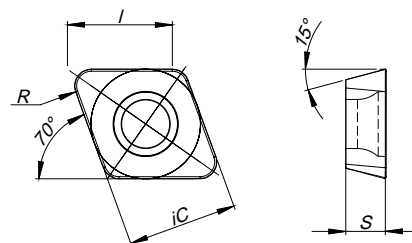
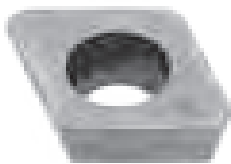

XDHW - PCD & PCBN
(HARDMILL)

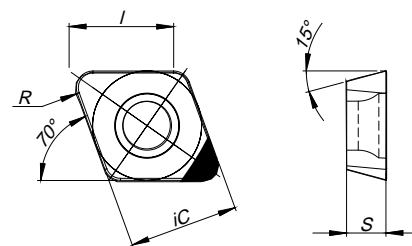

(1) Geometry code	(2) Grade code ISO Reference	P				K		N		H		Dimensions Dimensões Dimensiones (mm)			
		PVD				PVD		CVD	PCD	PVD	PCBN	iC	S	I	R
		M6	54	78	86	54	78	P2	D6	M6	S4				
1110905	XDHW 040105	○	○	○		○		⊗		○		4,00	1,59	4,00	0,50
1110573	XDHW 040110	⊗	⊗	⊗		⊗	⊗	⊗		⊗		4,00	1,59	4,00	1,00
1112316	XDHW 040110 FN								⊗			4,00	1,59	4,00	1,00
1112317	XDHW 040110 SN										⊗	4,00	1,59	4,00	1,00
1110532	XDHW 060210	⊗	⊗	⊗	⊗	⊗	⊗	⊗		⊗		6,50	2,38	6,20	1,00
1112318	XDHW 060210 FN								⊗			6,50	2,38	6,20	1,00
1111875	XDHW 060210 SN										⊗	6,50	2,38	6,20	1,00
1110565	XDHW 10T310	⊗	⊗	⊗	⊗	⊗	⊗	○		⊗		10,00	3,97	9,90	1,00
1112320	XDHW 10T310 FN								⊗			10,00	3,97	9,90	1,00
1112321	XDHW 10T310 SN										⊗	10,00	3,97	9,90	1,00

⊗ First choice | Primeira opção | 1ª opción ⊗ Stock item | Produto de stock | Itens de stock ○ Available under request (see page A-9) | Disponível sobre consulta (consulte a página A-9) | Disponible bajo consulta (mire página A-9) Insert order code = (1) Geometry Code + (2) Grade Code

LINEPRO 40095 | 40595 | 41095

SPARE PARTS | Complementos | Repuestos

Cutter ØDc	Insert Screw	Key (Torx)	Order separately		Order separately
			Key (Torx - Nm)	Torque Value	Screw Clamp
R41095 - 10 - 12	P0180401	XT06	DT0606	0,6	-
R40095 - 16 - 25	P0250503	XT08	DT0812	1,2	-
R40595 - 25 - 42	P0350800	XT15	DT1530	3,0	-
C40595 - 52 - 80	P0350800	XT15	DT1530	3,0	P0350750

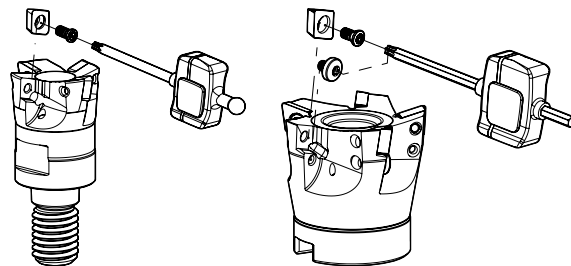

Note: The toolholder is supplied with the XT/PT key. To order the DT key please check the page A-241.
Check the procedures for the clamping screws on the page A-241.

GRADES SELECTION GUIDE | Guia para seleção de graus | Tabla para selección de calidades

ISO	PSM	Material	HB (Brinell)	Grades					PCD PDP410	PCBN PBH920
				← Wear Resistance			Toughness →			
				PHD103	PH6103	PH6910	PH6125	PH6135		
P	1	Unalloyed Steel	125-220		✓	✓	✓	✓		
	2	Low-Alloyed Steel	220-280		✓	✓	✓	✓		
	3	High-Alloyed Steel	280-380		✓	✓	✓	✓		
K	7	Malleable Cast Iron	130-230				✓			
	8	Grey Cast Iron	180-245				✓			
	9	Nodular Cast iron	160-250				✓			
N	10	Aluminium and Non Ferrous	30-130	✓					✓	
H	12	Hardened Steels	40-55 HRC		✓					✓



RECOMMENDED CUTTING CONDITIONS | Condições de corte recomendadas | Condiciones de corte recomendables

ISO	PSM	Material	HB (Brinell)	Vc (m/min)					PCD PDP410	PCBN PBH920
				← Wear Resistance			Toughness →			
				PHD103	PH6103	PH6910	PH6125	PH6135		
P	1	Unalloyed Steel	125-220	-	180-300	180-250	160-190	150-180	-	-
	2	Low-Alloyed Steel	220-280	-	180-250	170-210	140-180	140-170	-	-
	3	High-Alloyed Steel	280-380	-	180-230	160-200	130-160	120-150	-	-
K	7	Malleable Cast Iron	130-230	-	-	170-300	160-290	-	-	-
	8	Grey Cast Iron	180-245	-	-	150-250	140-240	-	-	-
	9	Nodular Cast iron	160-250	-	-	90-210	80-200	-	-	-
N	10	Aluminium and Non Ferrous	30-130	300-1000	-	-	-	-	800-3000	-
H	12	Hardened Steels	40-55 HRC	-	120-260	-	-	-	-	200-600

Insert	Feed fz (mm/t)		ap Rec.
	Roughing	Finishing	
XD... 04	0,10-0,20	0,10-0,15	0,1-0,5
XD... 06	0,15-0,30	0,10-0,25	0,2-0,8
XD... 10	0,15-0,35	0,10-0,30	0,2-0,8

(Note 1) Cutting conditions should be adjusted according to the machine and work rigidity.
(Note 2) If chattering occurs, reduce ap and Vc by 30% and keep the same fz per tooth.

RAMPING AND HELICAL INTERPOLATION

Descida em rampa e interpolação helicoidal | Bajada en rampa e interpolación circular

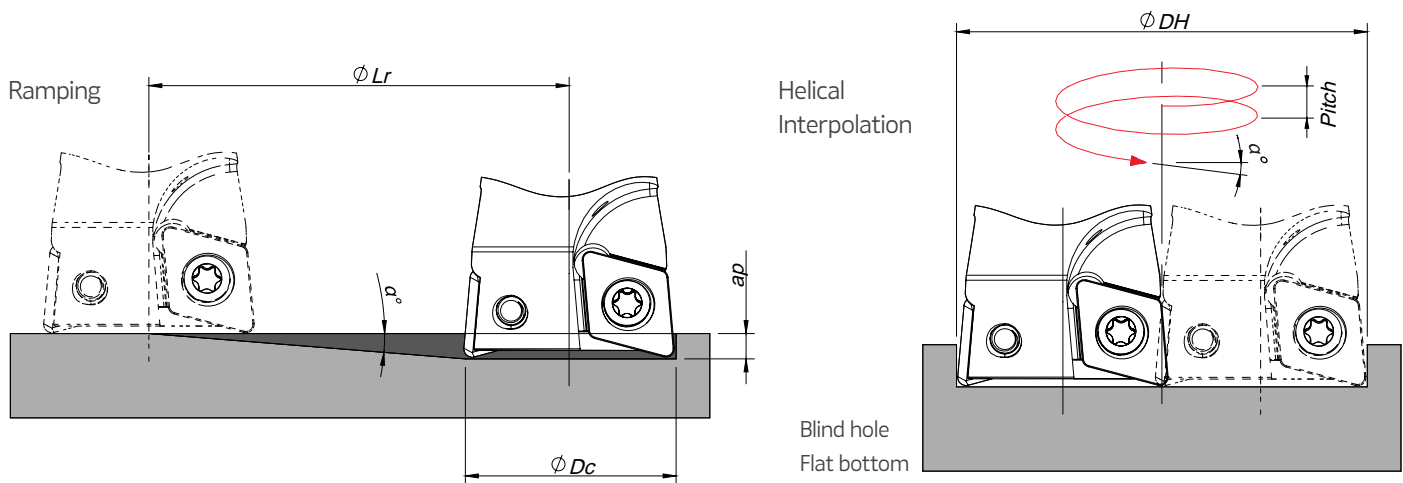

$$\phi di = \phi DH - \phi Dc$$

Insert	ϕDc	Ramping			Helical Interpolation		
		Max Ramp a°	Max a_p	Min L_r	ϕDH_{min}	ϕDH_{max}	Max Pitch/Rev.
XDHW 04...	10	7,3	0,8	6,2	18,0	-	3,2
	12	5,3	0,8	8,6	22,0	-	4,0
XDHW 06...	16	8	1,0	7,1	-	20,0	2,9
	20	5,7	1,0	10,0	-	24,0	3,5
	25	4	1,0	14,3	30,0	-	6,2
XDHW 10...	25	8,7	1,0	6,5	-	32,0	7,1
	35	5,2	1,0	11,0	38,0	-	5,6
	42	4	1,0	14,3	-	40,0	6,3
	52	3	1,0	19,1	48,0	-	5,1
	66	2,3	1,0	24,9	-	50,0	5,5
	80	1,8	1,0	31,8	48,0	-	11,1
					-	50,0	12,0
					68,0	-	9,4
					-	70,0	10,0
					82,0	-	8,8
					-	84,0	9,2
					102,0	-	8,2
					-	104,0	8,6
					130,0	-	8,1
					-	132,0	8,3
					158,0	-	7,7
					-	160,0	7,9

Note: During helical interpolation do not exceed max Pitch.

HARDMILL 72090

A

INSERTS CODIFICATION SYSTEM | Sistema de codificação de pastilhas | Sistema de codificación de insertos

ISO CODE	Insert size	Insert thickness	Insert radius	Cutting edge position angle	Cutting edge relief angle	Cutting edge conditions	Cut direction	Wiper edge length	Máx. Ap
XNHW	12	05	04	P	Z	F	R	-	015 030

Overview

Face milling

Hifeed milling

Shoulder milling

Profile milling

Hardmill

Center & Chamfer

Spot face

Spare Parts

Technical Data

End Mills

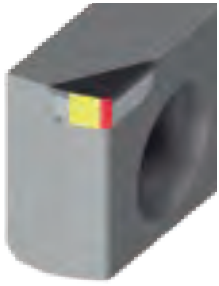

XNHW 120504 PZFR-0150045



XNHW 120504 PZFR-000080



XNHW 120508 PZFR-015045

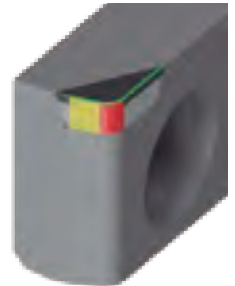

XNHW 120508 PZTR-015045



XNHW 120508 PZTR-000080



XNHW 1205 PZFR-020120



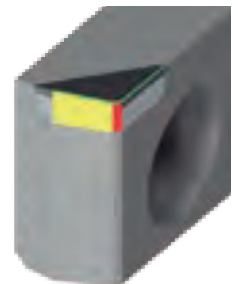

XNHW 1205 PZFR-030045



XNHW 1205 PZTR-030045

 Cutting edge Type (radius, chamfer)

 Wiper cutting edge

 Edge Preparation (F, T)

HARDMILL 72090

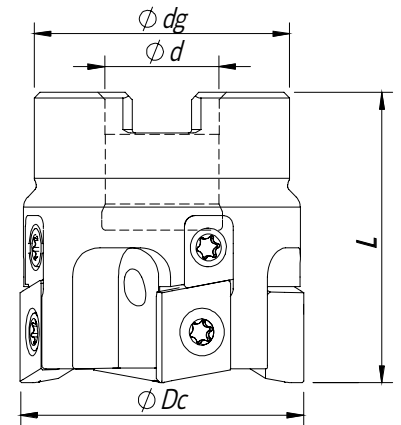

Arbor Mounting

$K_r=90^\circ$ | $\gamma_p=0^\circ$

Order code Código	Reference Referência Referencia		Dimensions Dimensões Dimensiones (mm)				Kg	Specifications		Insert Pastilha Inserto	Stock
			ϕDc	ϕd	ϕdg	L		Arbor Type	N max (mm)		
181129700	040A72090-04-016040	4	40	16	36	40	0,32	A	32 000	XNHW 1205...	
181129800	050A72090-04-022040	4	50	22	46	40	0,38	A	32 000	XNHW 1205...	
181129900	050A72090-05-022040	5	50	22	46	40	0,37	A	32 000	XNHW 1205...	
181130000	063A72090-04-022040	4	63	22	49	40	0,65	A	29 000	XNHW 1205...	
181130100	063A72090-07-022040	7	63	22	49	40	0,62	A	29 000	XNHW 1205...	
181130200	080A72090-05-027050	5	80	27	60	50	1,25	A	26 000	XNHW 1205...	
181130300	080A72090-09-027050	9	80	27	60	50	1,17	A	26 000	XNHW 1205...	
181130400	100A72090-06-032050	6	100	32	70	50	1,93	A	24 000	XNHW 1205...	
181130500	100A72090-12-032050	12	100	32	70	50	1,80	A	24 000	XNHW 1205...	
181130600	125A72090-08-040063	8	125	40	72	63	2,88	A	22 000	XNHW 1205...	
181130700	125A72090-14-040063	14	125	40	72	63	2,60	A	22 000	XNHW 1205...	
181135500	160A72090-10-040063	10	160	40	72	63	3,30	A	18 000	XNHW 1205...	
181135600	160A72090-16-040063	16	160	40	118	63	5,45	A	18 000	XNHW 1205...	

Stock item | Produto de stock | Itens de stock

Available under request (see page A-8) | Disponível sobre consulta (consulte a página A-8) | Disponible bajo consulta (mire pagina A-8)

SPARE PARTS | Complementos | Repuestos

Cutter ϕDc	Order separately				
	Insert Screw	Key (Torx)	Key (Torx - Nm)	Torque Value	Wedge
A72090 - 40-160	P0401100	XT15	DT1530	3,00	SETDEV AS 04 00

Note: The toolholder is supplied with the XT/PT key. To order the DT key please check the page A-241.
Check the procedures for the clamping screws on the page A-241.

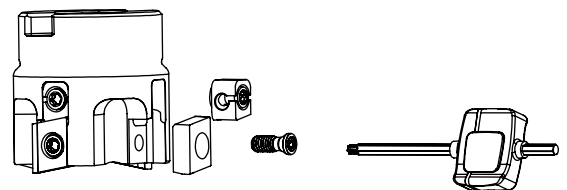

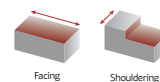

XNHW 1205... || Inserts | Pastilhas | Plaquetas

XNHW 1205 PZFR-020120

XNHW 120508 PZTR-000080

XNHW 120508 PZTR-015045

XNHW

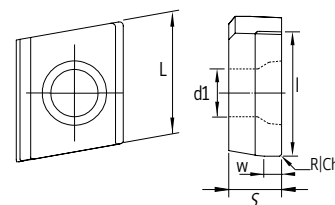

(1) Geometry code	(2) Grade code ISO Reference	N		Dimensions Dimensões Dimensiones (mm)					
		PCD		L	S	l	d1	r	W
		I3 PDP403	D6 PDP410						
1112564	XNHW 120504 PZFR-015045	○	○	12,25	5,40	4,50	4,80	0,40	1,50
1112565	XNHW 120504 PZFR-000080	○	○	12,25	5,40	8,00	4,80	0,40	-
1112566	XNHW 120508 PZFR-015045	⊗	○	12,25	5,40	4,50	4,80	0,80	1,50
1112551	XNHW 120508 PZTR-015045	⊗	○	12,25	5,40	4,50	4,80	0,80	1,50
1112552	XNHW 120508 PZTR-000080	⊗	○	12,25	5,40	8,00	4,80	0,80	-
1112553	XNHW 1205 PZFR-020120	⊗	○	12,25	5,40	12,00	4,80	-	2,00
1112567	XNHW 1205 PZFR-030045	○	○	12,25	5,40	4,50	4,80	-	3,00
1112568	XNHW 1205 PZTR-030045	○	○	12,25	5,40	4,50	4,80	-	3,00

⊗ First choice | Primeira opção | 1ª opción ⊗ Stock item | Produto de stock | Itens de stock ○ Available under request (see page A-9) | Disponível sobre consulta (consulte a página A-9) | Disponible bajo consulta (mire página A-9) Insert order code = (1) Geometry Code + (2) Grade Code

RECOMMENDED CUTTING CONDITIONS || Condições de corte recomendadas | Condiciones de corte recomendables

ISO	Material		HB (Brinell)	Vc (m/min)	Feed fz (mm/t)
	Work piece material	Type of treatment / alloy		PDP403	XNHW 12...
N	Aluminium wrought alloys		80	300 - 4000	0.05 - 0.40
			90	300 - 1500	
	Aluminium cast alloys	< 12% Si	130	300 - 5000	
		< 12% Si	90	300 - 3000	
		> 12% Si	100	300 - 1000	
	brass, red bronze		100	100 - 700	
		bronze	-	100 - 1500	
		lead-free copper and electrolytic copper	-	300 - 3000	
	Non-metallic materials	thermosetting plastics	-	80 - 300	
		fibre-reinforced plastics	200-320	80 - 300	
hard rubber			80 - 300		



CENTER & CHAMFER

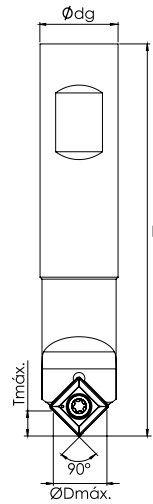

Order code Código	Reference Referência Referencia		Dimensions Dimensões Dimensiones (mm)						Kg	Insert Pastilha Inserto	Stock
			ØDmax.	Tmax.	Tmix.	Ødg	L	Angle °			
181147400	CHT S16H N11-45	1	13	6,5	1,0	16	100	45	0,146	SO..T 11T3..	
181147500	CHT S16M N11-45	1	13	6,5	1,0	16	150	45	0,180	SO..T 11T3..	

Order code Código	Designation Designação Designación	Nº Toolholder	Holder designation	Nº inserts	Insert Pastilha Inserto	Stock
1410286G4	PK SOMT 11T308 CHTS16H	1	CHT S16H N11-45	10	SOMT 11T308	
1410287G4	PK SOMT 11T308 CHTS16M	1	CHT S16M N11-45	10	SOMT 11T308	

Stock item | Produto de stock | Itens de stock

Available under request (see page A-8) | Disponível sobre consulta (consulte a página A-8) | Disponible bajo consulta (mire pagina A-8)

SO...T 11T3.. | Inserts | Pastilhas | Plaquitás

SOMT

SOGT NEW



SOMT | SOGT

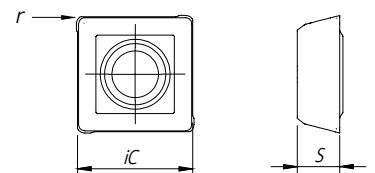

		P	M	K	Dimensions Dimensões Dimensiones (mm)			
		PVD	PVD	PVD	iC	S	l	r
⁽²⁾ Grade code		G4	G4	G4				
⁽¹⁾ Geometry code	ISO Reference	PH7920	PH7920	PH7920				
1112425	SOMT 11T308				10,87	3,97	11,00	0,80
1112973	SOGT 11T303				10,87	3,97	11,00	(0,30)

First choice | Primeira opção | 1ª opción

Stock item | Produto de stock | Itens de stock

Available under request (see page A-9) | Disponível sobre consulta (consulte a página A-9) | Disponible bajo consulta (mire pagina A-9)

Insert order code = (1) Geometry Code + (2) Grade Code

TOOL SELECTION || Selecção de ferramenta | Selección de herramienta

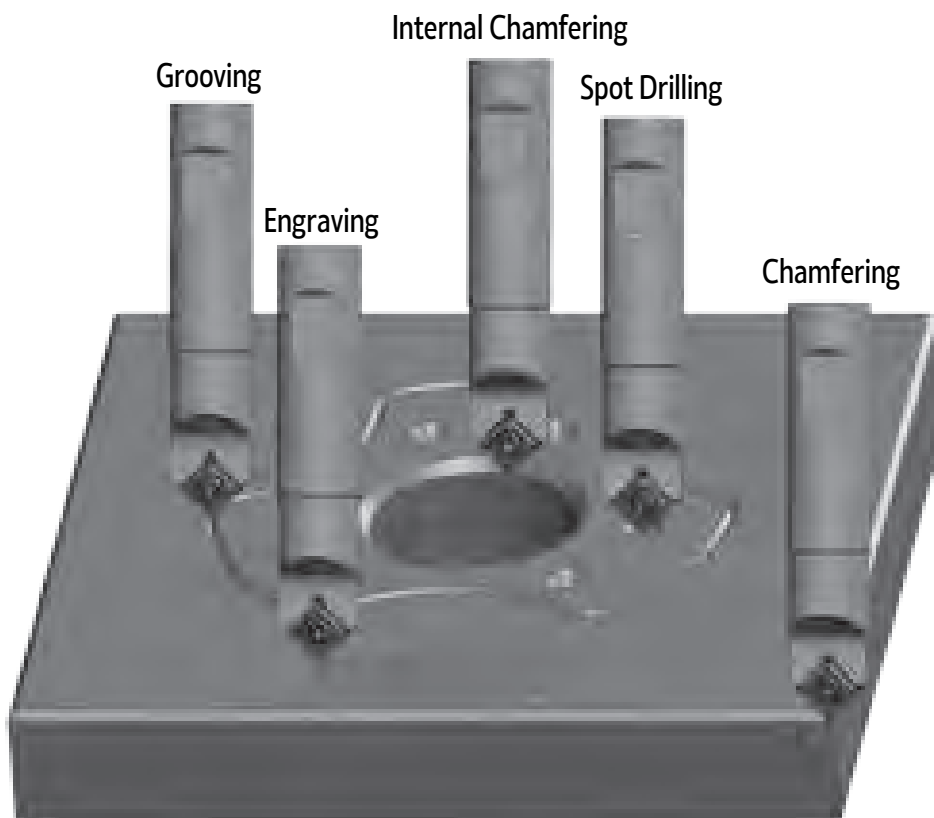

SPARE PARTS || Complementos | Repuestos

Cutter ØDc	Order separately			
	Insert Screw	Key (Torx)	Key (Torx - Nm)	Torque Value
CHT S16...	P0350800	XT15	DT1530	3,0

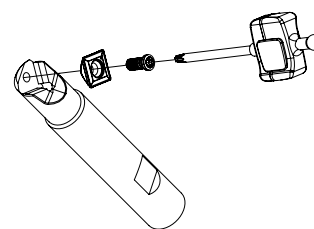

Note: The toolholder is supplied with the XT/PT key. To order the DT key please check the page A-241.
Check the procedures for the clamping screws on the page A-241.

RECOMMENDED CUTTING CONDITIONS || Condições de corte recomendadas | Condiciones de corte recomendables

ISO	PSM	Material	HB (Brinell)	Vc (m/min)	Feed fz (mm/t)	
				PH7920	SOMT 11T308	SOGT 11T303
P	1	Unalloyed Steel	125-220	120-150	0,04-0,08	0,05-0,10
	2	Low-Alloyed Steel	220-280	100-120	0,03-0,07	0,05-0,10
	3	High-Alloyed Steel	280-380	60-100	0,03-0,06	0,04-0,08
M	4	SS - Ferritic / Martensitic	200-330	100-150	0,04-0,07	0,03-0,06
	5	SS - Austenitic	200-330	80-120	0,03-0,06	0,03-0,06
	6	SS - Austenitic-ferritic (Duplex)	230-260	50-90	0,03-0,06	0,03-0,08
K	7	Malleable Cast Iron	130-230	90-150	0,05-0,10	0,05-0,10
	8	Grey Cast Iron	180-245	80-120	0,05-0,08	0,05-0,08
	9	Nodular Cast iron	160-250	70-110	0,04-0,08	0,04-0,08



SPOT FACE

A

MILLING

Overview

Face milling

Hi-feed milling

Shoulder milling

Profile milling

Hardmill

Center & Chamfer

Spot face

Spare Parts

Technical Data

End Mills



Note: Hole previously drilled

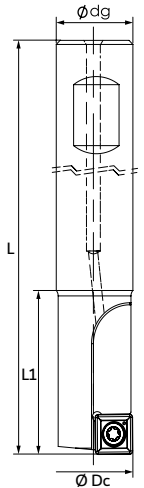

Order code Código	Reference Referência Referencia		Dimensions Dimensões Dimensiones (mm)				Kg	Insert Pastilha Inserto	Stock
			ϕDc	ϕdg	L	L1			
181150100	SP91 D10-W10/100-01-05	1	10	10	100	30	0,048	SPKX 05T104	
181150200	SP91 D11-W12/100-01-05	1	11	12	100	30	0,070	SPKX 05T104	
181150300	SP91 D13-W16/100-01-06	1	13	16	100	30	0,116	SPKX 060204	
181150400	SP91 D14-W16/120-01-06	1	14	16	120	30	0,123	SPKX 060204	
181150500	SP91 D17-W20/120-01-07	1	17	20	120	35	0,224	SPKX 070308	
181150600	SP91 D18-W20/140-01-07	1	18	20	140	35	0,272	SPKX 070308	
181150700	SP91 D20-W20/140-01-09	1	20	20	140	40	0,303	SPKX 090308	
181150800	SP91 D21-W25/150-01-09	1	21	25	150	40	0,449	SPKX 090308	
181150900	SP91 D25-W25/150-01-11	1	25	25	150	40	0,473	SPKX 110408	

Stock item | Produto de stock | Itens de stock

Available under request (see page A-8) | Disponível sobre consulta (consulte a página A-8) | Disponible bajo consulta (mire pagina A-8)

SPKX || Inserts | Pastilhas | Plaquitas

(PHC grade)

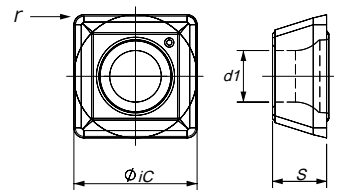

Geometry code	ISO Reference	P			M			K			Dimensions Dimensões Dimensiones (mm)			
		PVD			PVD			PVD						
		⁽²⁾ Grade code	68	66	J3	68	66	J3	68	66	J3	IC	S	d1
1111635	SPKX 05T104										5,00	1,98	2,20	0,40
1111282	SPKX 060204										6,00	2,38	2,55	0,80
1111636	SPKX 070308										7,94	3,18	2,85	0,80
1111637	SPKX 090308										9,80	3,18	4,10	0,80
1111285	SPKX 110408										11,50	4,80	4,40	0,80

First choice | Primeira opção | 1ª opción

Stock item | Produto de stock | Itens de stock

Available under request (see page A-9) | Disponível sobre consulta (consulte a página A-9) | Disponible bajo consulta (mire pagina A-9)

Insert order code = (1) Geometry Code + (2) Grade Code

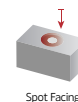

SPARE PARTS | Complementos | Repuestos

Order separately

Cutter ØDc	Insert Screw	Key (Torx)	Key (Torx - Nm)	Torque Value
10-11	P0200400	XT06	DT0606	0,6
13-14	P0220500	XT07	DT0709	0,9
17-18	P0250704	XT08	DT0812	1,2
20-21	P0350702	XT15	DT1530	3,0
25	P0400900	XT15	DT1530	3,0

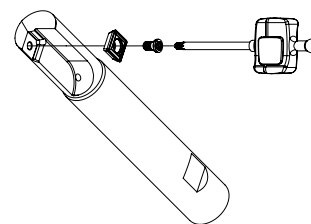

Note: The toolholder is supplied with the XT/PT key. To order the DT key please check the page A-241.
Check the procedures for the clamping screws on the page A-241.

GRADES SELECTION GUIDE | Guia para selecção de graus | Tabla para selección de calidades

ISO	PSM	Material	HB (Brinell)	Grades		
				← Wear Resistance		Toughness →
				PH6920	PH6930	PHC930
P	1	Unalloyed Steel	125-220	✓	✓	✓
	2	Low-Alloyed Steel	220-280	✓	✓	✓
	3	High-Alloyed Steel	280-380	✓	✓	✓
M	4	SS - Ferritic / Martensitic	200-330	✓	✓	✓
	5	SS - Austenitic	200-330	✓	✓	✓
	6	SS - Austenitic-ferritic (Duplex)	230-260	✓	✓	✓
K	8	Grey Cast Iron	180-245	✓	✓	✓
	9	Nodular Cast iron	160-250	✓	✓	✓

Good Conditions
 Average Conditions
 Difficult Conditions

RECOMMENDED CUTTING CONDITIONS | Condições de corte recomendadas | Condiciones de corte recomendables

ISO	PSM	Material	HB (Brinell)	Vc (m/min)		
				← Wear Resistance		Toughness →
				PH6920	PH6930	PHC930
P	1	Unalloyed Steel	125-220	180-250	160-240	160-240
	2	Low-Alloyed Steel	220-280	160-220	140-200	140-200
	3	High-Alloyed Steel	280-380	130-180	110-160	110-160
M	4	SS - Ferritic / Martensitic	200-330	170-230	140-210	140-210
	5	SS - Austenitic	200-330	160-200	130-200	130-200
	6	SS - Austenitic-ferritic (Duplex)	230-260	140-180	120-190	120-190
K	8	Grey Cast Iron	180-245	180-250	150-220	150-220
	9	Nodular Cast iron	160-250	130-200	110-180	110-180

ISO	PSM	Material	HB (Brinell)	Feed fz (mm/t)				
				SPKX 05...	SPKX 06...	SPKX 07...	SPKX 09...	SPKX 11...
				P	1	Unalloyed Steel	125-220	0,05-0,08
2	Low-Alloyed Steel	220-280	0,06-0,12		0,08-0,15	0,10-0,18	0,12-0,22	0,12-0,25
3	High-Alloyed Steel	280-380	0,06-0,10		0,08-0,15	0,10-0,20	0,12-0,23	0,12-0,26
M	4	SS - Ferritic / Martensitic	200-330	0,05-0,10	0,06-0,12	0,08-0,15	0,09-0,16	0,10-0,20
	5	SS - Austenitic	200-330	0,04-0,08	0,05-0,10	0,06-0,12	0,07-0,13	0,08-0,18
	6	SS - Austenitic-ferritic (Duplex)	230-260	0,04-0,08	0,05-0,11	0,06-0,13	0,07-0,14	0,08-0,19
K	8	Grey Cast Iron	180-245	0,06-0,12	0,08-0,16	0,12-0,20	0,15-0,25	0,15-0,30
	9	Nodular Cast iron	160-250	0,06-0,10	0,08-0,15	0,10-0,18	0,12-0,20	0,15-0,25

SPARE PARTS

MULTIFIT DENSIMET ANTI-VIBRATION | Shank | Adaptador | Fijación

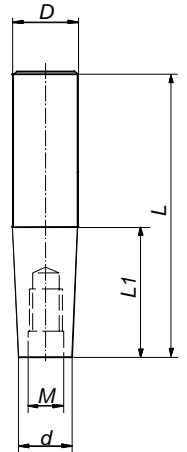

order code	Reference	Dimensions (mm)					Stock
		D	L1	L	d	M	
1191008A0	AC-RI-D12-M06-L040-AV	12	40	90	9,8	M6	⊗
1191009A0	AC-RI-D12-M06-L060-AV	12	60	110	9,8	M6	⊗
1191021A0	AC-RI-D12-M06-L080-AV	12	80	130	9,8	M6	⊗
1191010A0	AC-RI-D16-M08-L040-AV	16	40	95	12,8	M8	⊗
1191011A0	AC-RI-D16-M08-L060-AV	16	60	115	12,8	M8	⊗
1191012A0	AC-RI-D16-M08-L080-AV	16	80	135	12,8	M8	⊗
1191013A0	AC-RI-D16-M08-L100-AV	16	100	155	12,8	M8	⊗
1191022A0	AC-RI-D16-M08-L120-AV	16	120	175	12,8	M8	⊗
1191014A0	AC-RI-D20-M10-L040-AV	20	40	100	15,8	M10	⊗
1191015A0	AC-RI-D20-M10-L060-AV	20	60	120	15,8	M10	⊗
1191016A0	AC-RI-D20-M10-L080-AV	20	80	140	15,8	M10	○
1191017A0	AC-RI-D20-M10-L100-AV	20	100	160	15,8	M10	○
1191018A0	AC-RI-D20-M10-L120-AV	20	120	180	15,8	M10	○
1191026A0	AC-RI-D20-M10-L080-D17,8-AV	20	80	140	17,8	M10	⊗
1191027A0	AC-RI-D20-M10-L100-D17,8-AV	20	100	160	17,8	M10	⊗
1191028A0	AC-RI-D20-M10-L120-D17,8-AV	20	120	180	17,8	M10	⊗
1191023A0	AC-RI-D25-M12-L060-AV	25	60	125	20,8	M12	⊗
1191024A0	AC-RI-D25-M12-L080-AV	25	80	145	20,8	M12	⊗
1191025A0	AC-RI-D25-M12-L100-AV	25	100	165	20,8	M12	⊗

⊗ Stock item | Produto de stock | Itens de stock

○ Available under request | Disponível sobre consulta | Disponible bajo consulta

MULTIFIT CARBIDE ANTI-VIBRATION | Shank | Adaptador | Fijación

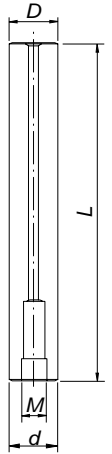

order code	Reference	Dimensions (mm)				Stock
		D	L	d	M	
219102600	AC-RI-D12-M06-L100-HW	12	100	12	M6	☺
219102700	AC-RI-D12-M06-L150-HW	12	150	12	M6	☺
219102800	AC-RI-D16-M08-L100-HW	16	100	16	M8	☺
219102900	AC-RI-D16-M08-L150-HW	16	150	16	M8	☺
219103000	AC-RI-D20-M10-L150-HW	20	150	20	M10	☺
219103100	AC-RI-D20-M10-L200-HW	20	200	20	M10	☺
219103200	AC-RI-D25-M12-L150-HW	25	150	25	M12	☺
219103300	AC-RI-D25-M12-L200-HW	25	200	25	M12	☺
219103400	AC-RI-D32-M16-L250-HW	32	250	32	M16	☺

☺ Stock item | Producto de stock | Itens de stock

○ Available under request | Disponível sobre consulta | Disponible bajo consulta

A

MILLING

Overview

Face milling

Hifeed milling

Shoulder milling

Profile milling

Hardmill

Center & Chamfer

Spot face

Spare Parts

Technical Data

End Mills

SPARE PARTS

A

MULTIFIT CYLINDRICAL IN STEEL | Shank | Adaptador | Fijación

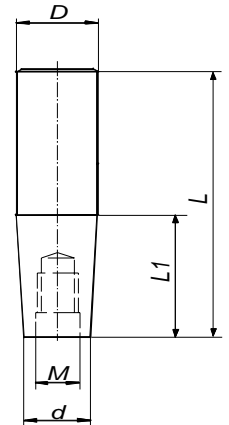

order code	Reference	Dimensions (mm)					Stock
		D	L1	L	d	M	
229000500	AC-RI-D12-M06-L020	12	20	65	9,8	M6	☼
229000600	AC-RI-D16-M08-L040	16	40	88	12,8	M8	☼
229000700	AC-RI-D20-M10-L045	20	45	95	17,8	M10	☼
229000800	AC-RI-D25-M12-L050	25	50	106	20,8	M12	☼
229000900	AC-RI-D32-M16-L050	32	50	110	28,8	M16	☼

☼ Stock item | Produto de stock | Itens de stock

○ Available under request | Disponível sobre consulta | Disponible bajo consulta

MILLING

Overview

Face milling

Hi-feed milling

Shoulder milling

Profile milling

Hardmill

Center & Chamfer

Spot face

Spare Parts

Technical Data

End Mills

MULTIFIT EXTENSIONS FOR THREADED TYPE CUTTER | Shank | Adaptador | Fijación

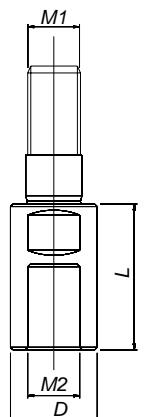

order code	Reference	Dimensions (mm)				Stock
		D	M1	M2	L	
229003200	AL-M08-L040-M08	13,8	M8	M8	40	☼
229003600	AL-M10-L060-M10	18,0	M10	M10	60	☼
229003700	AL-M12-L060-M12	21,0	M12	M12	60	☼
229003100	AL-M16-L060-M16	29,0	M16	M16	60	☼

☼ Stock item | Produto de stock | Itens de stock

○ Available under request | Disponível sobre consulta | Disponible bajo consulta

MULTIFIT REDUCERS FOR THREADED TYPE CUTTER || Shank | Adaptador | Fijación

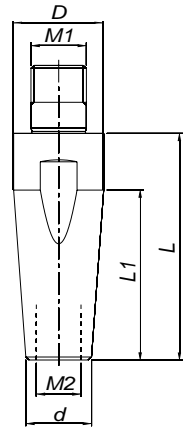

order code	Reference	Dimensions (mm)						Stock
		M1	M2	D	d	L	L1	
229012100	AL-M08-L040-M06	M8	M6	13,8	10,0	40	25	☉
229012200	AL-M10-L040-M08	M10	M8	18,0	13,8	40	25	☉
229012300	AL-M12-L040-M10	M12	M10	21,0	18,0	40	15	☉
229012400	AL-M16-L040-M12	M16	M12	29,0	21,0	40	19	☉

☉ Stock item | Produto de stock | Itens de stock

○ Available under request | Disponível sobre consulta | Disponible bajo consulta

- A
- MILLING
- Overview
- Face milling
- Hifeed milling
- Shoulder milling
- Profile milling
- Hardmill
- Center & Chamfer
- Spot face
- Spare Parts
- Technical Data
- End Mills

SPARE PARTS

A

SHIM SCREW

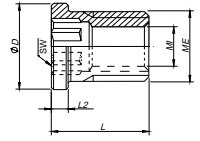

order code	Screw	Dimensions (mm)					
		SW	MI	ME	ØD	L	L2
290030400	T0503509	3,5	M3,5 x 0,6	M5,0 x 0,5	6,3	7	1,2

Overview

Face milling

ADJUSTMENT SCREW

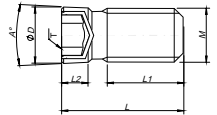

order code	Screw	T (torx)	Dimensions (mm)					
			M	ØD	A°	L	L1	L2
290051500	F0601441	T-20	M6 x 1,0	6,3	5°	13,6	8,5	3,2

Hi-feed milling

Shoulder milling

Profile milling

DIFFERENTIAL SCREW

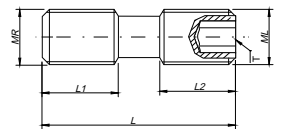

order code	Screw	T (torx)	Dimensions (mm)				
			MR	ML	L	L1	L2
290016300	F0701800	T-20	M7 x 0,75	M7 x 0,75	18	7,5	7,5

Hardmill

Center & Chamfer

Spot face

INSERT SCREW

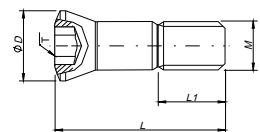

order code	Screw	T (torx)	Dimensions (mm)			
			M	ØD	L	L1
290013900	P0400925	T-15	M4 x 0,5	5,80	8,6	3,5
290010600	P0500925	T-20	M5 x 0,5	6,70	9,5	3,4
290014400	P0501325	T-20	M5 x 0,5	7,50	12,8	4,5
290014000	P0501525	T-20	M5 x 0,5	7,50	15,5	4,5

Spare Parts

Technical Data

End Mills

INSERT SCREW

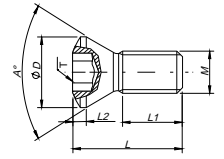
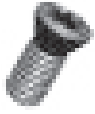

order code	Screw	T (torx)	Dimensions (mm)					
			M	ØD	A°	L	L1	L2
290078800	P0180300	T-GIP	M1,8 x 0,35	2,45	60°	3,4	1,5	0,5
290058400	P0180400	T-GIP	M1,8 x 0,35	2,45	60°	3,7	1,8	0,5
290011300	P0180401	T-6	M1,8 x 0,35	2,75	55°	3,6	1,9	0,4
290031400	P0200500	T-6	M2 x 0,4	2,80	60°	4,7	2,9	0,6
290030600	P0220500	T-7	M2,2 x 0,45	3,20	60°	5,0	3,0	0,6
290033100	P0250503	T-8	M2,5 x 0,45	3,45	60°	5,5	2,8	0,7
290048900	P0250601	T-8	M2,5 x 0,45	3,45	60°	6,0	3,5	0,8
290013400	P0250700	T-8	M2,5 x 0,45	3,3	55	7	4	0,8
290031300	P0250704	T-8	M2,5 x 0,45	3,45	60°	6,5	4,0	0,7
290009100	P0300800	T-9	M3 x 0,5	4,4	60°	7,4	4,2	0,8
290081700	P0350702	T-15	M3,5	5,3	55	7	3,1	2
290019900	P0350800	T-15	M3,5 x 0,6	5,5	60°	7,7	3,7	1
290027100	P0350902	T-10	M3,5 x 0,6	4,7	60°	9	5,5	0,4
290030900	P0350903	T-15	M3,5 x 0,6	5,45	60°	9	6	0,6
290075200	P0350904	T-15	M3,5 x 0,6	4,8	60°	9	5	0,8
290005800	P0351200	T-15	M3,5 x 0,6	5,30	60°	12	8	1,4
119198800	P0400803	T-15	M4 x 0,7	5,5	60°	8	5,5	1
290048200	P0400900	T-15	M4 x 0,7	5,5	60°	9	5,5	1
290075600	P0401065	T-15	M4 x 0,6	5,7	60	10	6	1
290007000	P0401100	T-15	M4 x 0,7	5,3	55	11	8	2
290047500	P0401200	T-15	M4 x 0,7	5,5	60°	11	6	1,2
290026900	P0451001	T-20	M4,5 x 0,75	6,6	55°	10,5	5,5	1
290006700	P0451400	T-20	M4,5 x 0,75	7,2	60°	14	9	1
290017500	P0501100	T-20	M5 x 0,8	6,4	43°	11	5,9	0,5
290031700	P0501300	T-20	M5 x 0,8	7	60°	12,8	8	1,3
290078900	P0501302	T-20	M5 x 0,5	7	60°	13	8,2	0,8
290048300	P0601402	T-20	M6 x 1,0	8,4	60°	14	9	0,9

SPARE PARTS

A

ADJUSTMENT SCREW

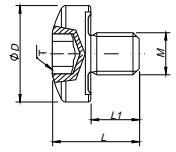

order code	Screw	T (torx)	Dimensions (mm)			
			M	ØD	L	L1
290014200	P0350750	T-15	M3,5 x 0,6	8,00	7,2	4,0

MILLING

Overview

WASHER SCREW

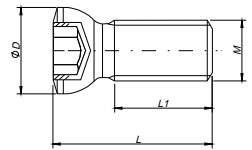

order code	Screw	Dimensions (mm)			
		M	ØD	L	L1
290075600	P0401065	M4 x 0,6	5,7	10,0	6,0
290018500	P0601265	M6 x 1,0	9,00	12,4	6,5
290011000	P0601765	M6 x 1,0	9,00	17,0	11,0
290028400	P0802265	M8 x 1,25	11,0	22,0	15,0

Face milling

Hifeed milling

Shoulder milling

OTHERS

Washer	Order Code	Reference
	119200900	HC01200
	290060200	HC01400
	290002900	HC01800

Cartridge Screw	Order Code	Reference
	119169600	D0602096

Profile milling

Hardmill

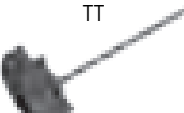
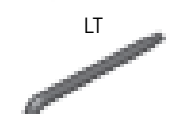
Torx Keys	Order Code	Reference
	290058600	XT 06IP
	290011400	XT 06
	290012900	XT07
	290011700	XT 08
	290025700	XT 09
	290013100	XT 10
	290012400	XT 15
	290013200	XT 20
	290014800	PT 15
	290014900	PT 20
	290056000	TT 20
	290059500	LT 30

Shim	Order Code	Reference
	160022218	CS130300
	290060400	CT160300
	290060300	CT220300

Center & Chamfer

Spotface

Spare Parts

Spring Pin	Order Code	Reference
	290060600	BE02500
	290060500	BE04000

Wedge (Insert)	Order Code	Reference
	290060900	WA7001
	290061100	WA7003
	119200100	SETDEV AS 04 00

Technical Data

End Mills

Wedge (Cartridge)	Order Code	Reference
	290061000	WA7002
	290061200	WA7004

Hex Key	Order Code	Reference
 SS  TS	290021200	SS40
	290021300	SS50
	290058700	TS40

Screw for Coolant Supply	Order Code	Reference	M	Ø Ext.
	119163000	J0123510	12	37,9
	119163100	J0164110	16	45,0
	119163200	J0204610	20	54,8

Tork Keys	Order Code	Reference	Torx	Nm
	290078300	DT0606IP	6IP	0,6
	290059600	DT0606	6	0,6
	290059700	DT0709	7	0,9
	290059800	DT0812	8	1,2
	290059900	DT0914	9	1,4
	290060000	DT1020	10	2,0
	290047800	DT1530	15	3,0
290078400	DT2050	20	5,0	

DIN 6368 Wrench	Order Code	Reference
	290058000	SD6368-12
	290058100	SD6368-16
	290058200	SD6368-20

Retaining Screw	Order Code	Reference
	290087700	D1603500
	290087800	D2004000

PROCEDURES FOR CLAMPING SCREWS

1. Always use a torque wrench to ensure that screws are correctly tightened (please confirm torques data on catalogue). Torque that is too high will negatively affect the performance of the tool and can cause screw and insert breakage. Torque that is too low will cause insert movement, vibration and degrade the cutting result. Dedicated adjustable torque wrench can be ordered separately (please see above).
2. Clean the insert seat.
Make sure that the insert seat is free from dust or chips from the machining. If necessary, clean the insert seat with compressed air.
3. Check the insert seat.
Before assembly cutter it is important to ensure that the insert seat has not been damaged during machining or handling.
4. Apply sufficient screw lubrication to prevent seizure. Lubricant should be applied to the screw threads as well as to the screw head face.
5. Replace worn or damaged screws.

