

# Eccentric Collet

**PRECISE**

Order Number	Dimensions (mm)						Milling Machine Adjustment	Lathe Machine Adjustment
	ØD	ØD1	ØD2	L	L1	L2		
EC 2025	20	25	41	47	4	30	+0.5 / -0.2	+0.25 / -0.1
EC 2532	25	32	49	54	6	33		
EC 3240	32	40	58	59	6	35		
EC 4050	40	50	60	87	7	64		

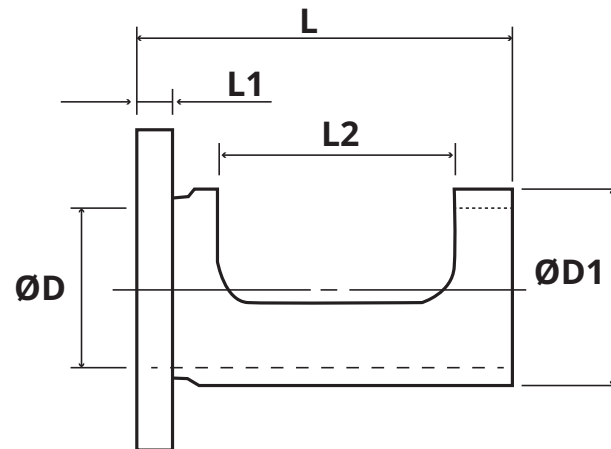
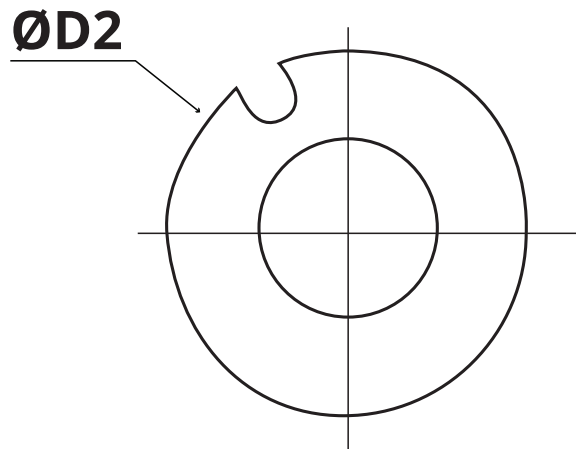

**LIVETOOLS.**  
 Machine Tool People.  
[www.livetools.com.au](http://www.livetools.com.au)

sales@livetools.com.au  
 +61 2 4017 0198  
 115 Young Street, Carrington  
 NSW 2294 Australia