



# FLUX

## Multi- functional Flood Lights

FLUX flood lights can be used in gardens, courtyards, tennis courts, landscapes, residential applications, or as extra lighting in parking lots. It is also ideal for park and campus pathways, or other outdoor applications that require a cost-effective, solar LED flood light.



For more information, please visit our website:  
[www.soltechlighting.com](http://www.soltechlighting.com)

6W, 20W FLUX Multifunctional Flood Lights

## FEATURES & BENEFITS



### Versatile Design

- Ideal outdoors as a flood light or wall pack
- Ideal as a portable work light or camping light
- Designed for round pole and wall pack installation

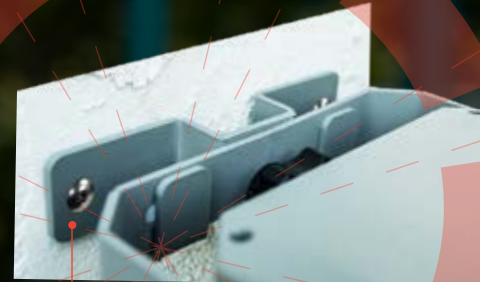

### Generate & Store More Solar Energy

- Adjusting the solar panel angle maximizes solar energy collection, and allows snow, dirt, and other debris to slide or wash off
- This solar flood light's two-piece design allows the separate solar panel to always collect energy from the sun without affecting the direction of the light fixture



### High Brightness and Smart Power Consumption

- 170 Lm/w, the highest efficiency in the industry
- Microwave motion sensor and one-key automatic dimming
- 7 operating modes are programmable via remote control or controls on the fixture (remote is included.)



### Low Maintenance Design

- Die cast A380 aluminum fixture housing is rust-free
- Grade A LifePO<sub>4</sub> Battery Pack, 2000+ full charging cycles

### Removable Wall Mount Installation Design

FLUX can be removed and used in case of an emergency. Untighten the big center screw and lift up the light.

REMOTE CONTROL



# DIMENSIONAL DRAWINGS

## FLUX 6W

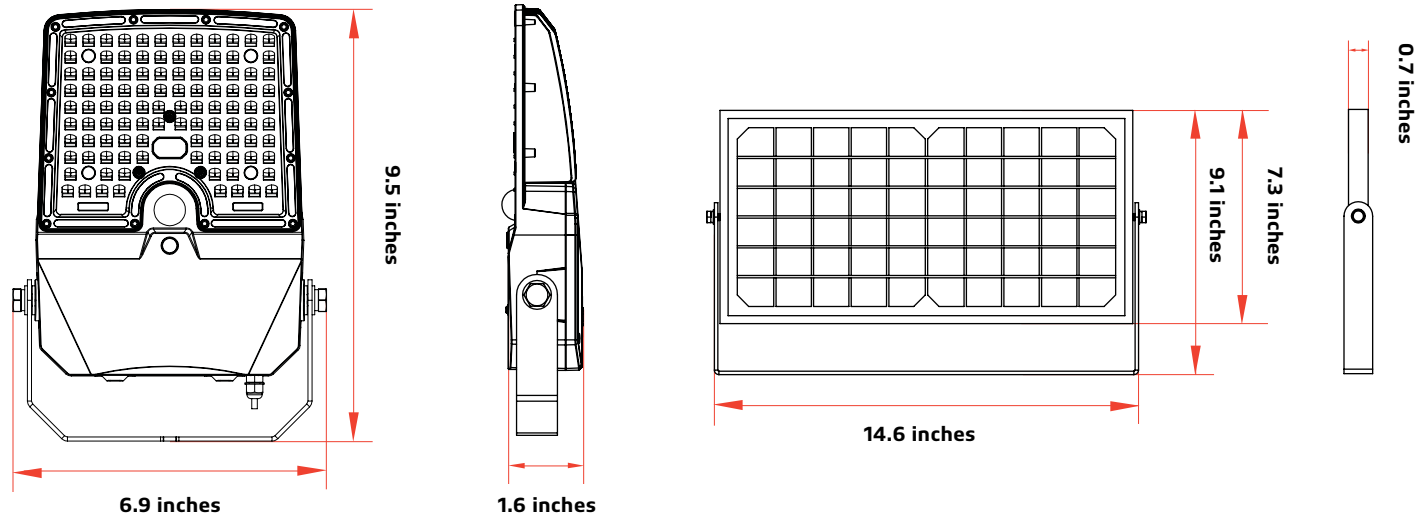

## FLUX 20W

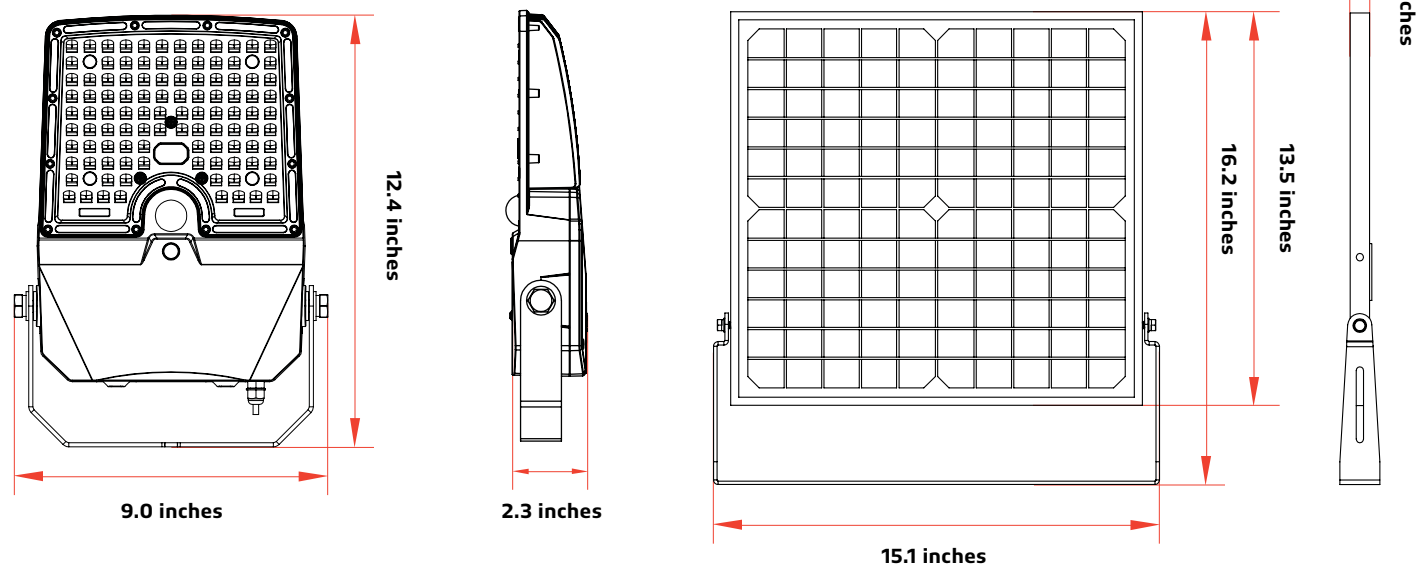

# SPECIFICATIONS & PERFORMANCE

## 6W, 20W FLUX Multifunctional Flood Lights

FLUX multifunctional flood light can be widely used in gardens, courtyards, tennis courts, landscapes, residential applications, or as extra lighting in parking lots.

SPECIFICATIONS	FLUX 6W	FLUX 20W
LED NOMINAL POWER	6W	20W
SOLAR PANEL	Mono-Crystalline Silicon 10V 10W	Mono-Crystalline Silicon 10V 20W
LIFEPO <sub>4</sub> BATTERY	6.4V 3AH	6.4V 12AH
LUMEN OUTPUT@4,000K	1,020	3,400
PRODUCT SIZE	Solar Panel 7.3 X 14.6 Inches Light 9.5X 6.9X 1.6 Inches	Solar Panel 13.5 X 15.1 Inches Light 12.4 X 9.0 X 2.3 Inches
EPA	1.41	2.51
IP RATING	IP66	IP66
CRI	CRI > 70	CRI > 70
BEAM SPREAD	>130°, NEMA type 7 Very Wide	>130°, NEMA type 7 Very Wide
CASTING	PC & ALUMINUM	PC & ALUMINUM
CABLE LENGTH	16.5 FT	16.5 FT
EFFICIENCY@4,000K	170 LM/W	170 LM/W
* CHARGING TIME	6 Hours (1000W/m <sup>2</sup> )	6 Hours (1000W/m <sup>2</sup> )
RUN TIME	5-7 Rainy Days	5-7 Rainy Days
OPERATION MODE	7 Operating Modes	7 Operating Modes
CCT	4,000K	4,000K
* OPERATING TEMPERATURE	-20°C/-4°F to 122°F	-20°C/-4°F to 122°F
* CHARGING TEMPERATURE	0°C/-32°F to 149°F	0°C/-32°F to 149°F

\* The temperature can impact the battery's charging and normal operation.  
 \* The solar charge time data is based on 77 degree F ambient temperature, with the panel pointed directly at the solar radiation. The standard radiation value is 1000W/m<sup>2</sup>.

# IES LIGHT DISTRIBUTION

## FLUX 6W

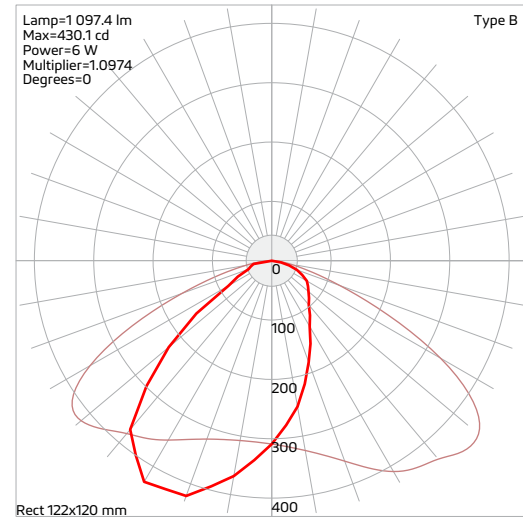

## FLUX 20W

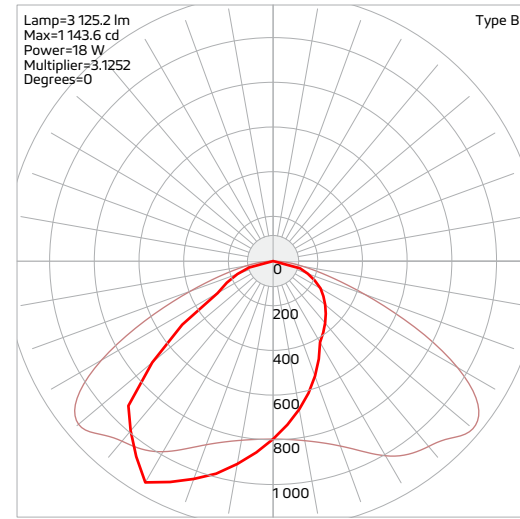

# PRODUCT NUMBER BUILDER

**Example: STL-FLX204WMBK**

This example product number is for FLUX 20 watt, 4,000K CCT, wall mount installation, with black finish.

SERIES	WATTAGE	COLOR TEMPERATURE	MOUNTING OPTIONS	FINISH
STL-FLX=FLUX	6=6W 1,020 LUMENS 20=20W 3,400 LUMENS	4=4,000K	WM=WALL MOUNT PM=POLE MOUNT	BK=BLACK BR=BRONZE

-  -  -  -

**Sample Number: STL-FLX20XYZZ**

Please **DO NOT** send the generic sample number directly to our salesperson. Use the information in the chart, above, to create a model number with the correct series, wattage, CCT, mounting options, and finish for the product options that you want.

# MOUNTING ACCESSORIES (6W, 20W)



## WALL MOUNT

### 01. Permanent Mounting

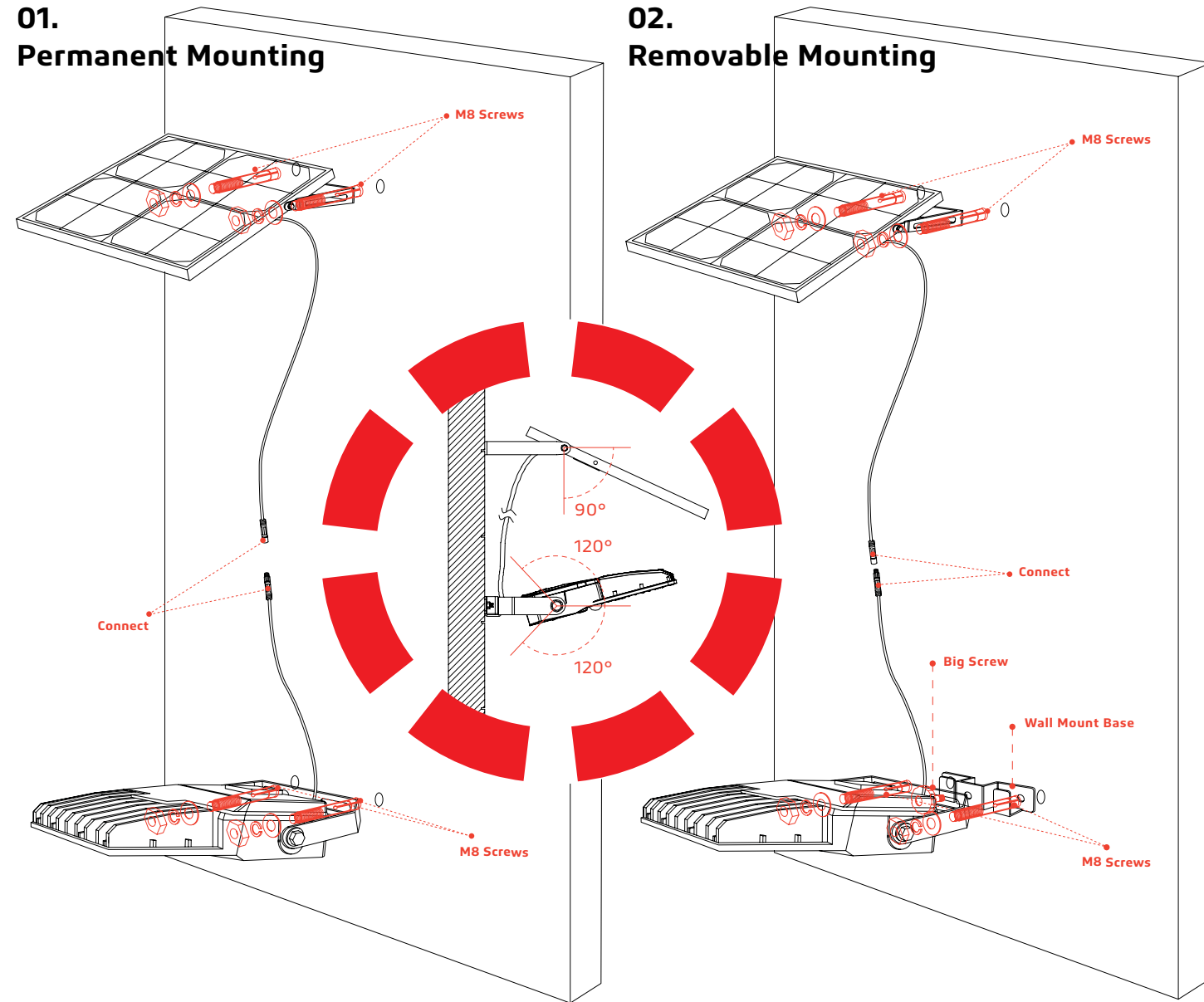

#### First mount the solar panel:

1. Drill two holes into the wall surface then use the screw kit to secure the solar panel bracket on the wall.
2. After you secure the solar panel bracket, attach the solar panel to the bracket.

#### Then mount the fixture:

3. Drill two holes into the wall surface. Attach the bracket to the fixture then secure to the wall surface with the screw kit.
4. Connect the light and solar panel cables.

### 02. Removable Mounting

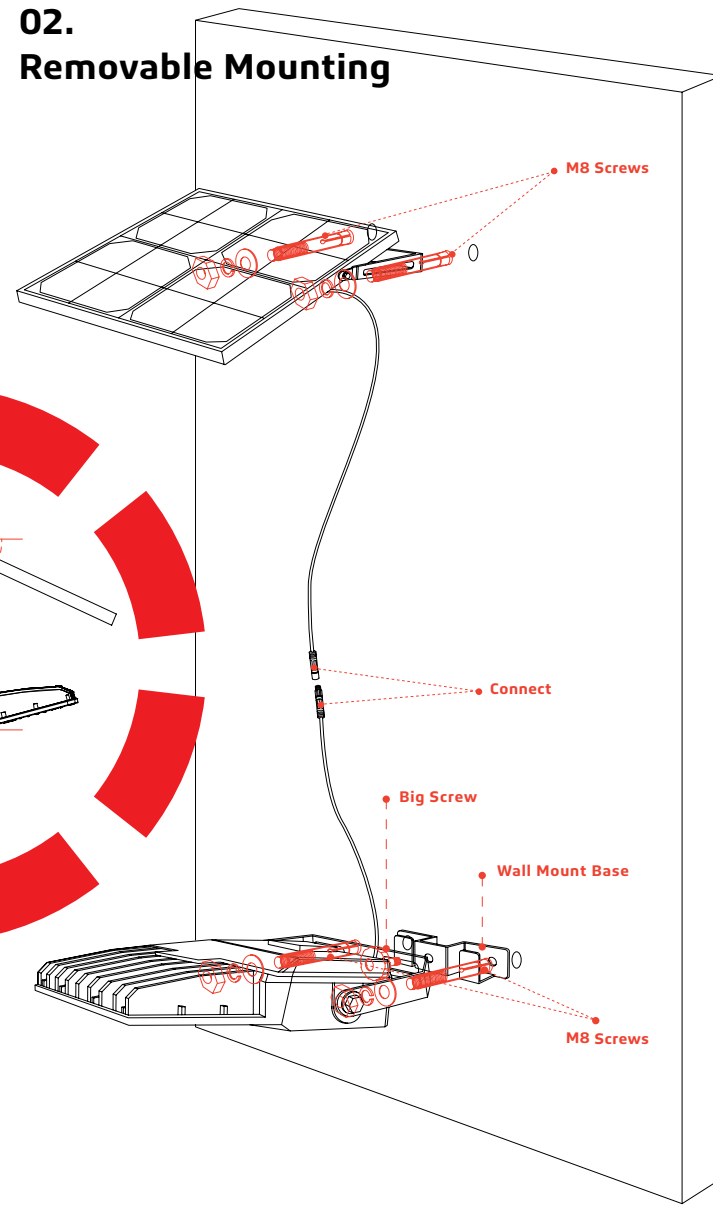

#### First mount the solar panel:

1. Drill two holes into the wall surface, then use the screw kit to secure the solar panel bracket on the wall.
2. After you secure the solar panel bracket, attach the solar panel to the bracket.

#### Then mount the fixture:

3. Drill two holes into the wall surface, then screw in the wall mount base to the wall.

4. Attach the bracket to the fixture and then hang the bracket on the wall mount base. Lastly, use the big screw nob to hold them together.
5. Connect the light and solar panel cables.

## POLE MOUNT

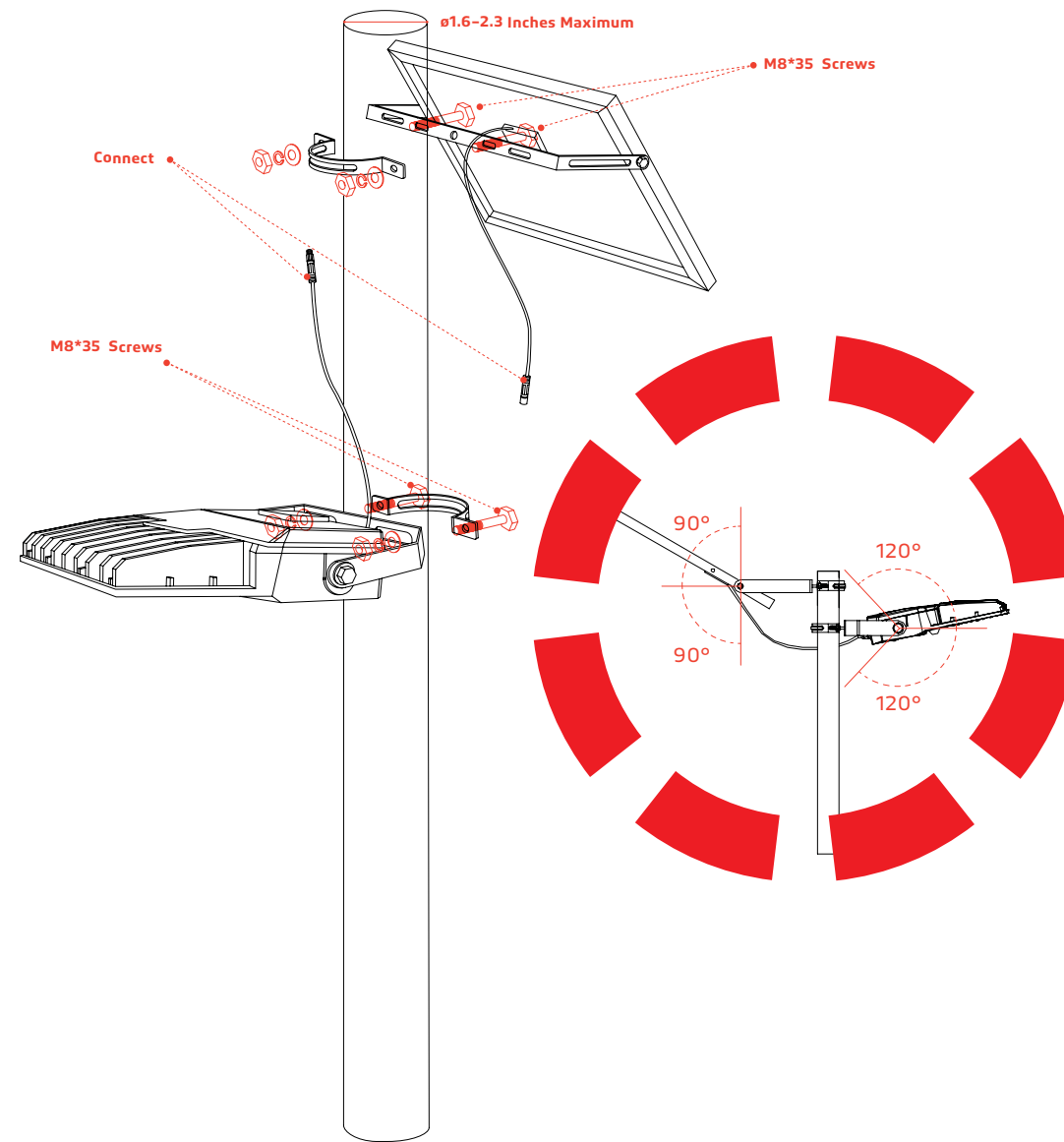

#### First, mount the solar panel to the pole:

1. Use the screw kit to secure the pole mount base and the solar panel bracket to the pole.
2. Then attach the solar panel to the bracket.

#### Then, mount the fixture:

3. Attach the bracket to the fixture.
4. Use the screw kit to secure the fixture bracket to the pole mount base on the pole.
5. Connect the light and solar panel cables.

# REMOTE CONTROL (6W, 20W)

## REMOTE CONTROL INSTRUCTIONS

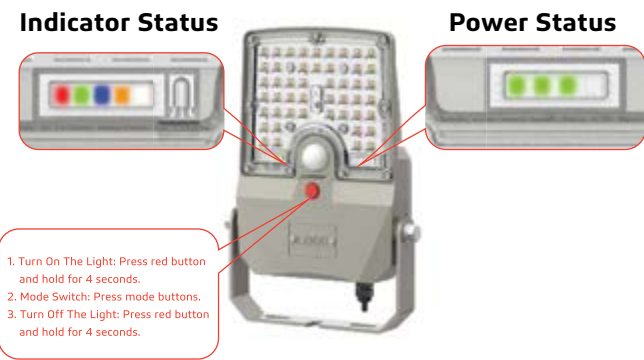

Remote Buttons	Indicator Status
A	Red
B	Green
C	Red+Green
D	Blue
E	Blue+Red
F	Blue+Green

### Additional Notes

- The flood lights "Turn On" time depends on the client's local time (Turn-on Light Level:< 20Lux).
- A, B, C, D, E and F modes have memory functions. For example, if you press mode A and then press the OFF button, Mode A will still be activated when you turn the light on again until end user resets the mode.



## MOTION SENSOR MODES

**A** Light on 100% if motion is detected, stand-by period is 60 seconds. Light will turn off when no motion is detected.

**B** Light on 100% if motion is detected, stand-by period 60 seconds. Light will dim down to 5% output when no motion is detected.

**C** Light on 100% if motion is detected, stand-by period is 120 seconds. Light will turn off when no motion is detected.

**D** Light on 100% if motion is detected, stand-by period is 120 seconds. Light will dim down to 5% output when no motion is detected.

**E** Light on 50% for 3 hours (Sensor disabled), then returns to motion sensor mode. If motion detected, stand-by period 60 seconds. Light will turn off when no motion is detected.

**F** Light on 50% for 3 hours (Sensor disabled), then returns to motion sensor mode. If motion detected, stand-by period is 60 seconds. Light will dim down to 5% output when no motion is detected.

**RST** Light on 50% for 2 hours, then dims down to 20% for 6 hours, then dims down to 10% until dawn (Sensor disabled).