

# MAILBOX DELUXE POST ASSEMBLY INSTRUCTIONS

Before installing your deluxe Whitehall mailbox post, consult your local branch of the US post office for road setback requirement and height from roadbed or curb. Post is designed for a 40" average height from ground to base of mailbox.

- A - Whitehall Mailbox - 1 (Sold Separately)
- B - 54" Deluxe Post - 1
- C - 1/4" Lag Bolts - 2
- D - Mounting Brackets - 2
- E - 10/24 x 1/2" Panhead Screws - 8
- F - Finial - 1
- G - Tube of Silicon Sealer
- H - Clear Plastic Cup Washer - 4
- I - Screw Cover - 4 (four color choices)
- J - Plastic Lag Bolt Covers - 2 of each color

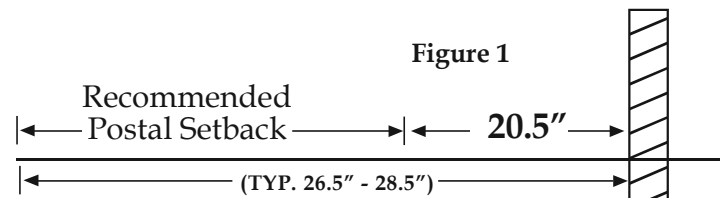

- 1) Purchase a 4" x 4" x 48" piece of treated lumber from your local lumber yard or home center.
- 2) From post office recommended road setback line add 20.5" and mark position on ground for front edge of post. (See Figure 1)
- 3) Place the 4" x 4" post into the hole so that the face of the post is at the marked line (See step 2) leaving at least 18" out of the ground. (See Figure 2)
- 4) Partially backfill the hole around the 4" x 4" post. Using a level make sure the post is vertical.
- 5) Complete the back fill of the post hole packing the earth firmly. Recheck for vertical and adjust if necessary, then repack soil. Note: For a more permanent installation you may use concrete mix to backfill the hole unless it is against local post office or county road commission guidelines.
- 6) Slide aluminum post (B) over the partially buried 4x4 with the two bolt holes positioned away from the road and the aluminum post resting on the ground. (See Figure 2)
- 7) Plumb the aluminum post to vertical and use 2 - 1/4" x 2" lag bolts provided (C) to secure aluminum post to treated post. (See Figure 2 - drilling pilot holes in the wood may be necessary) Please Note: Apply small amount of Silicon Sealer (G) in and around holes before securing the two bolts to the post.
- 8) Use the plastic lag bolt covers (J) to cover exposed lag bolt once the silicone has dried
- 9) Apply small amount of Silicon Sealer (G) in and around holes on brackets (D) and attach to deluxe post (B) facing the street using 4 screws (E) and cup washers (H). (See Figure 3) DO NOT tighten screws until mailbox is attached. (if a double mailbox mount is being used, the road set back will be recommended postal set back plus 9", 2 sets of bracket are used and brackets are set parallel with the street)
- 10) Place finial (F) over top of post (B) and, using a rubber mallet, tap finial down firmly on the post.

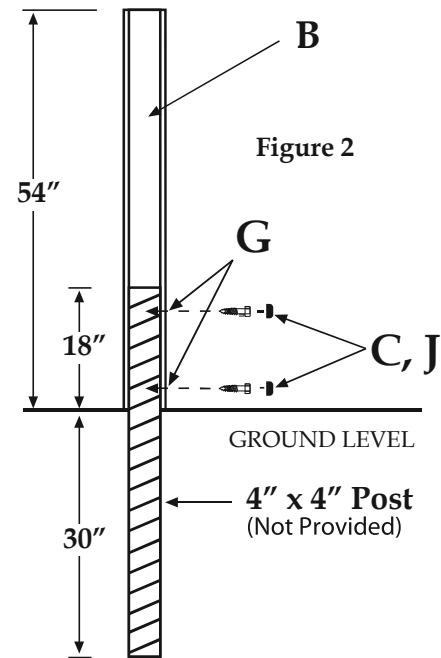

## Attaching your mailbox to the deluxe post and brackets:

- 1) Apply a small amount of Silicon Sealer (G) in and around the 4 holes top of the brackets (D). Place the mailbox (A) on top of the brackets (D) with the back of the box against the post (B) and the box centered over the brackets.
- 2) Using 4 screws (E) provided, reach inside the mailbox and place them thru the 4 holes and into the bracket (threaded holes) hand tighten. (Loosening the brackets on the post may be necessary to get alignment. If so retighten the brackets to the post once the box is secure).
- 3) Use a Phillips screwdriver to tighten the 4 screws inside the mailbox and 4 screws on the brackets.
- 4) Place matching screw cover (I) over the screws (E) and cup washers (H) on the brackets.

