

# ALL-O-MATIC®



Intertek

UL-325 **6th edition**,  
UL-991 & CSA C22.2  
#247 Compliant

WWW.ALLOMATIC.NET

## BLDC SLIDERS Installation Manual



# TABLE OF CONTENTS

|   |       |
|---|-------|
| Important safety instructions.....                              | 2     |
| Different UL 325 class types.....                               | 3-4   |
| Concrete pad installation.....                                  | 5-8   |
| Different installation types (front & rear mounts).....         | 9     |
| Gate travel adjustment.....                                     | 10    |
| Directional settings.....                                       | 11    |
| Electrical power connection.....                                | 12    |
| Typical loop layout.....  | 13-14 |
| Accessory & Loop rack connections.....                          | 15-16 |
| Three button station system installation.....                   | 17    |
| Entrapment Protection Installation For Sliding Gates.....       | 18    |
| Entrapment Protection Device connections.....                   | 19    |
| Master/Slave connection.....                                    | 20    |
| Magnetic/Solenoid lock installation.....                        | 21    |
| Radio receiver hookup.....                                      | 22    |
| Open and close electronic reversing sensor(ERDs) adjustment.... | 23    |
| Timer settings.....   | 24    |
| Programable relay & Leaf delay.....                             | 25    |
| Dip switch functions.....                                       | 26    |
| Solar panel installation.....                                   | 27    |
| External solar installation.....                                | 28    |
| Led diagnostics.....  | 29    |
| Emergency release.....  | 30-31 |
| Pad lock tabs.....  | 32    |

# IMPORTANT SAFETY INSTRUCTIONS

## **WARNING**

### **To reduce the risk of injury:**

READ AND FOLLOW ALL INSTALLATION INSTRUCTIONS. DO NOT THINK OF STARTING UNTIL YOU HAVE READ AND UNDERSTAND THESE DIRECTIONS. IF THERE IS SOMETHING YOU DO NOT UNDERSTAND CALL US.

**Never** let children operate or play with gate controls. Keep the remote control away from children.

Locate the control station: (a) within sight of the gate, and (b) at a minimum height of 5 feet so small children cannot reach it.

Install the Entrapment Warning Placard next to the control station in a prominent location.

For products having a manual release, instruct the end user on the operation of the manual release. Use the manual release only when the gate is not moving.

Always keep people and objects away from the gate. No one should cross the path of the moving gate.

This operator must be tested monthly. The gate must reverse on contact with a ridged object or stop when an object activates the non-contact sensors. After adjusting the force or the limit travel, re-test the gate operator. Failure to adjust and retest the gate operator properly may cause severe injury or death.

Keep gates properly maintained. Have a qualified service person make repairs to gate hardware. It takes many years of experience to make proper adjustments to gate hardware and operators.

This entrance is for vehicles only. Pedestrian must use separate entrance.

There is nothing on a gate operator that is easily repaired without a great deal of experience. Save yourself some time and call a qualified Gate Service Contractor who knows your type of gate operator.

## **SAVE THESE INSTRUCTIONS**

# **INSTALL THE GATE OPERATOR ONLY WHEN YOU HAVE READ THE FOLLOWING:**

- \*Confirm that the gate operator being installed is appropriate for the application.
  - \*Confirm that the gate is designed and built according to current published industry standards.
  - \*Confirm that all appropriate safety features and safety accessory devices are being incorporated, including all entrapment protection devices.
  - \*Make sure that the gate works freely before installing the operator.
  - \*Repair or service worn or damaged gate hardware before installation of the operator.
  - \*Eliminate all gaps in a sliding gate below a 6 foot height that permits a 2 ¼ inch sphere to pass through any location, including the area of the adjacent fence covered when the gate is in the open position.
  - \*Eliminate all gaps in a swinging gate below a 4 foot height that permit a 4 inch sphere to pass through any location, including the hinge area of the gate.
  - \*Operator must be disconnected from the power source before attempting any installation of accessories.
  - \*Install this gate operator according to our installation instructions.
  - \*Adjust the operator clutch or load sensing device to the minimum force setting that will still allow for reliable gate operation.
  - \*Install the operator inside the fence line(do not install the operator on the public side of fence line).
  - \*Install a proper electrical ground to a gate operator.
  - \*Controls intended for user activation must be located at least six feet (6') away from any moving part of the gate and where the user is prevented from reaching over, under, around or through the gate to operate the controls. Outdoor or easily accessible controls shall have a security feature to prevent unauthorized use.
- The Stop and/or Reset button must be located in the line-of-sight of the gate. Activation of the reset control shall not cause the operator to start.
- \*Install a minimum of two(2) WARNING SIGNS, one on each side of the gate where easily visible and take pictures of the installation.
  - \*Test all safety features for proper function before placing the automatic vehicular gate into service.
  - \*Train owner/users about basic functions and safety features of the gate system, including how to turn off the power and how to operate the manual disconnect feature.
  - \*Leave safety instructions, product literature, installation manual and maintenance manual with end user.
  - \*Explain to the owner/user the importance of routine service and retesting on a monthly basis.

# DIFFERENT UL 325 CLASS TYPES

## **Class one: Residential**

A vehicular gate operator intended for use in garages or parking areas associated with a residence of one to four single families.

## **Class Two: Commercial or General Public Access**

A vehicular gate operator intended for use at a commercial location or building such as a multi-family housing unit (five or more single family units), hotel, garages, retail stores, or other buildings accessible by or servicing the general public.

## **Class three: Industrial or limited Access**

A vehicular gate operator intended for use at an industrial location or building such as a factory, loading dock area or other locations not accessible by or intended to service the general public.

## **Class Four: Restricted Access**

A vehicular gate operator intended for use at a guarded industrial location or building such as airport security areas or other restricted access locations not servicing the general public where unauthorized access is prevented via supervision by security personnel.

## **Other components required to satisfy UL 325**

Each class must have two monitored entrapment protection devices in each entrapment zone to sense and react to obstructions within two seconds.

## **The six types of obstruction sensing systems are:**

### **Type A:**

Inherent entrapment protection system. This system must sense and initiate the reverse of the gate within two seconds of contact with a solid object.

### **Type B 1:**

Non-contact sensor (photoelectric sensor or equivalent). This system shall upon sensing an obstruction in the direction of travel of the gate, reverse the gate within a maximum of 2 s.

### **Type B2:**

Contact sensor (edge device or equivalent). This system shall, upon sensing an obstruction in the direction of travel of the gate: Initiate the reversal of the gate with a maximum of 2 s.

### **Type C:**

Inherent force limiting, inherent adjustable clutch or pressure relief valve.

### **Type D:**

Actuating device requiring continuous pressure to maintain opening or closing motion of the gate.

**All of All-O-Matic Inc's Gate operators conform to the most ridged Class One.**

# CONCRETE PAD PLACEMENT FOR SL-45DC

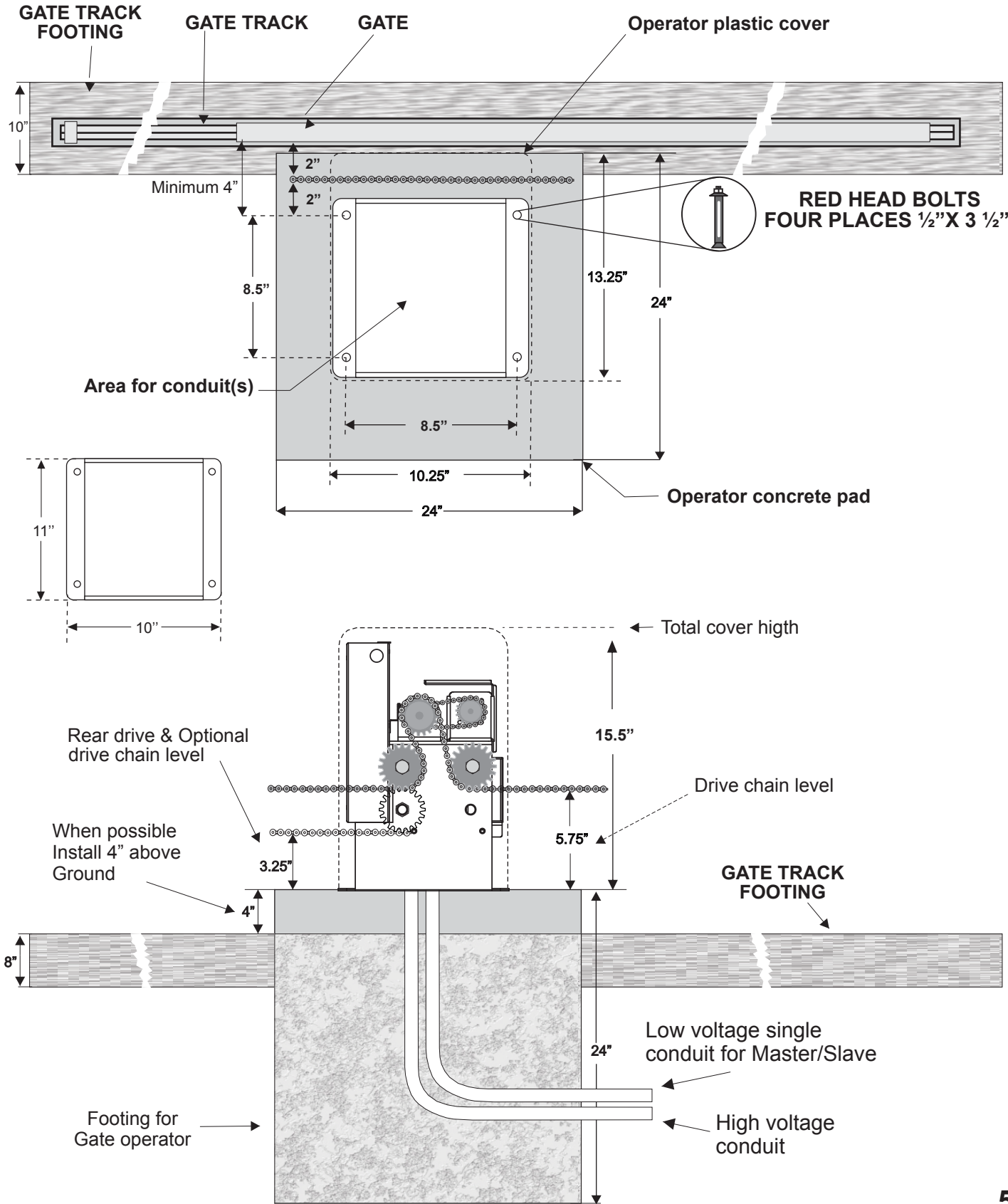

# CONCRETE PAD PLACEMENT FOR **SL-90DCFP**

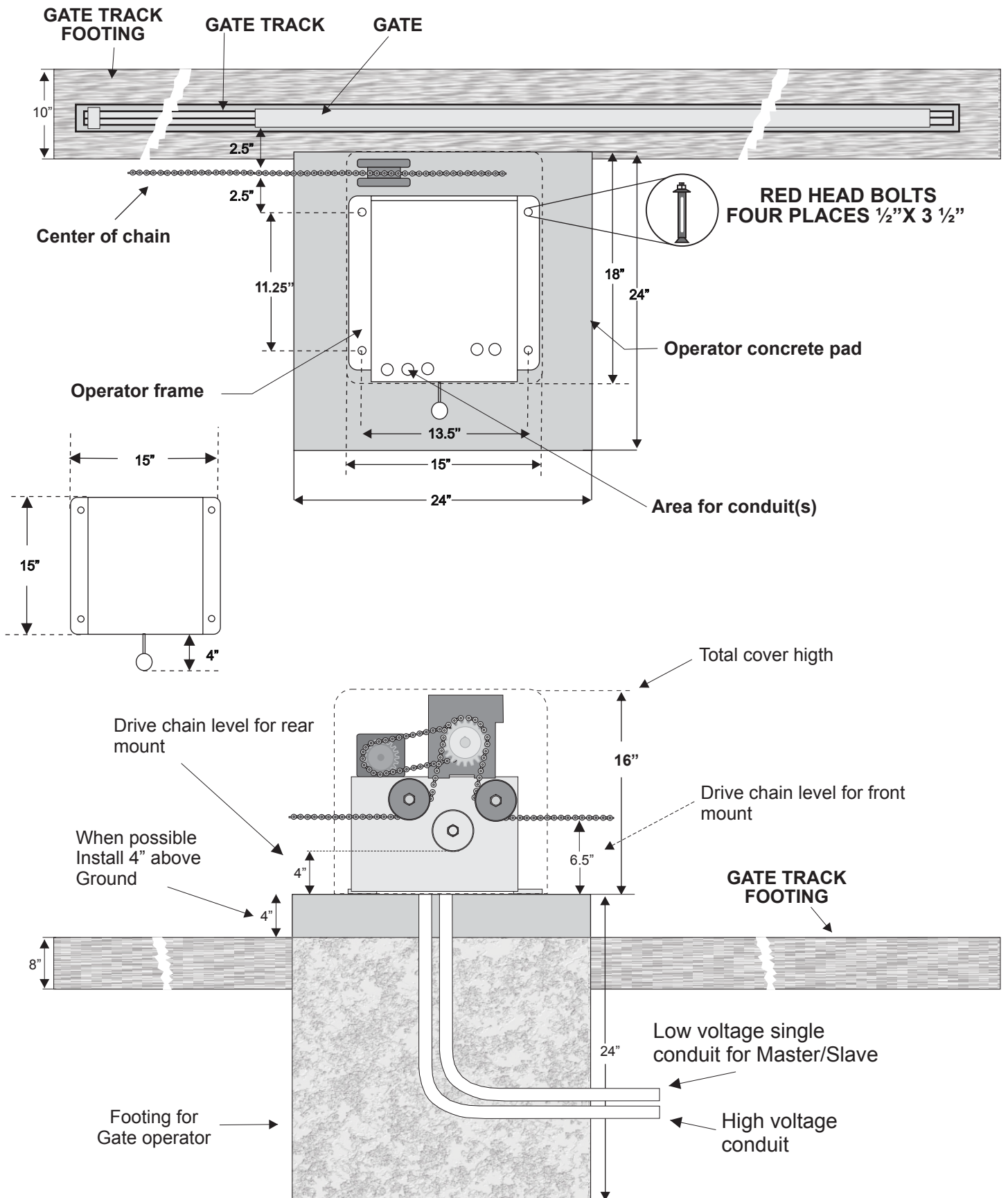



# CONCRETE PAD PLACEMENT FOR SL-100DC

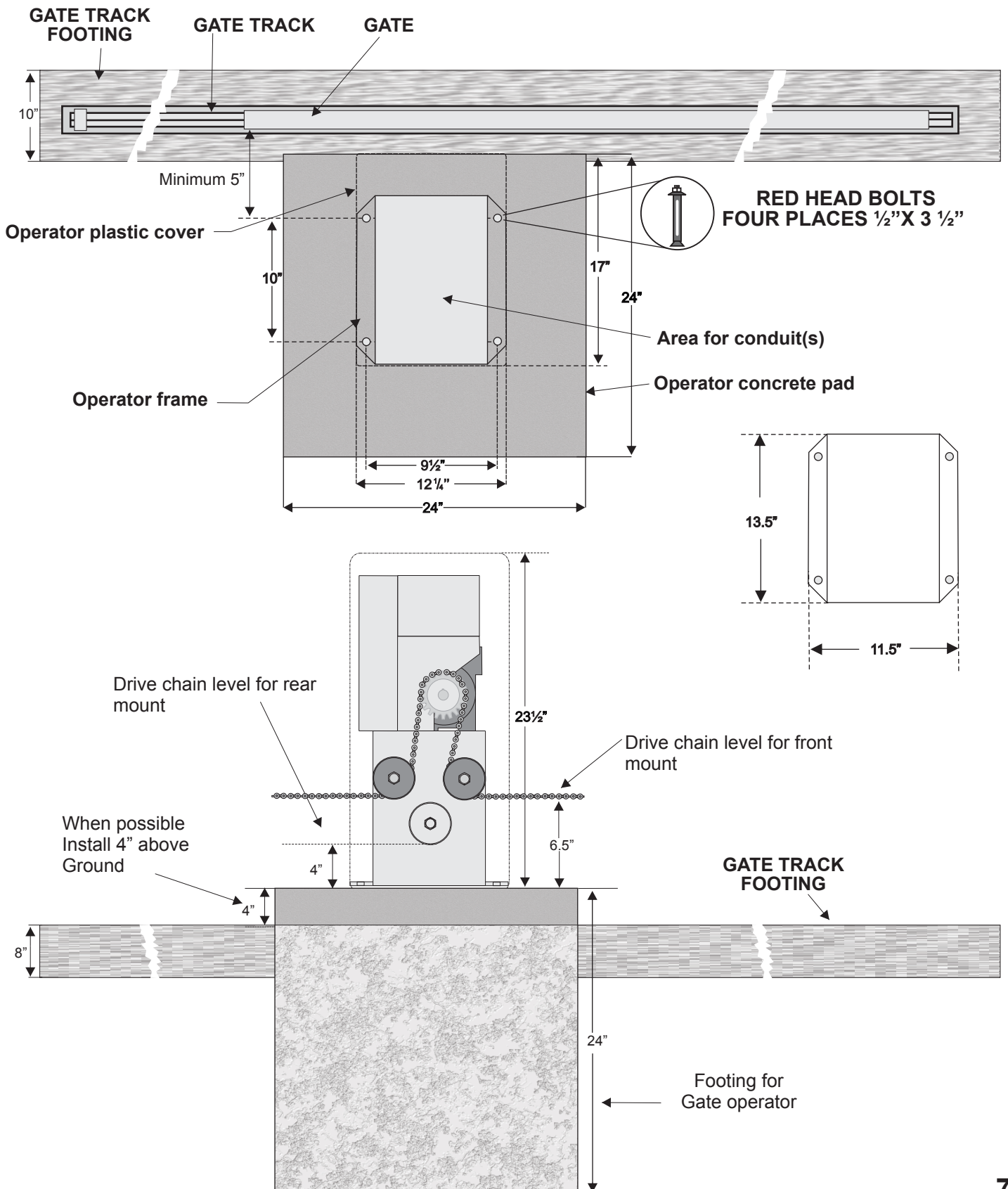

# CONCRETE PAD PLACEMENT FOR SL-150DC

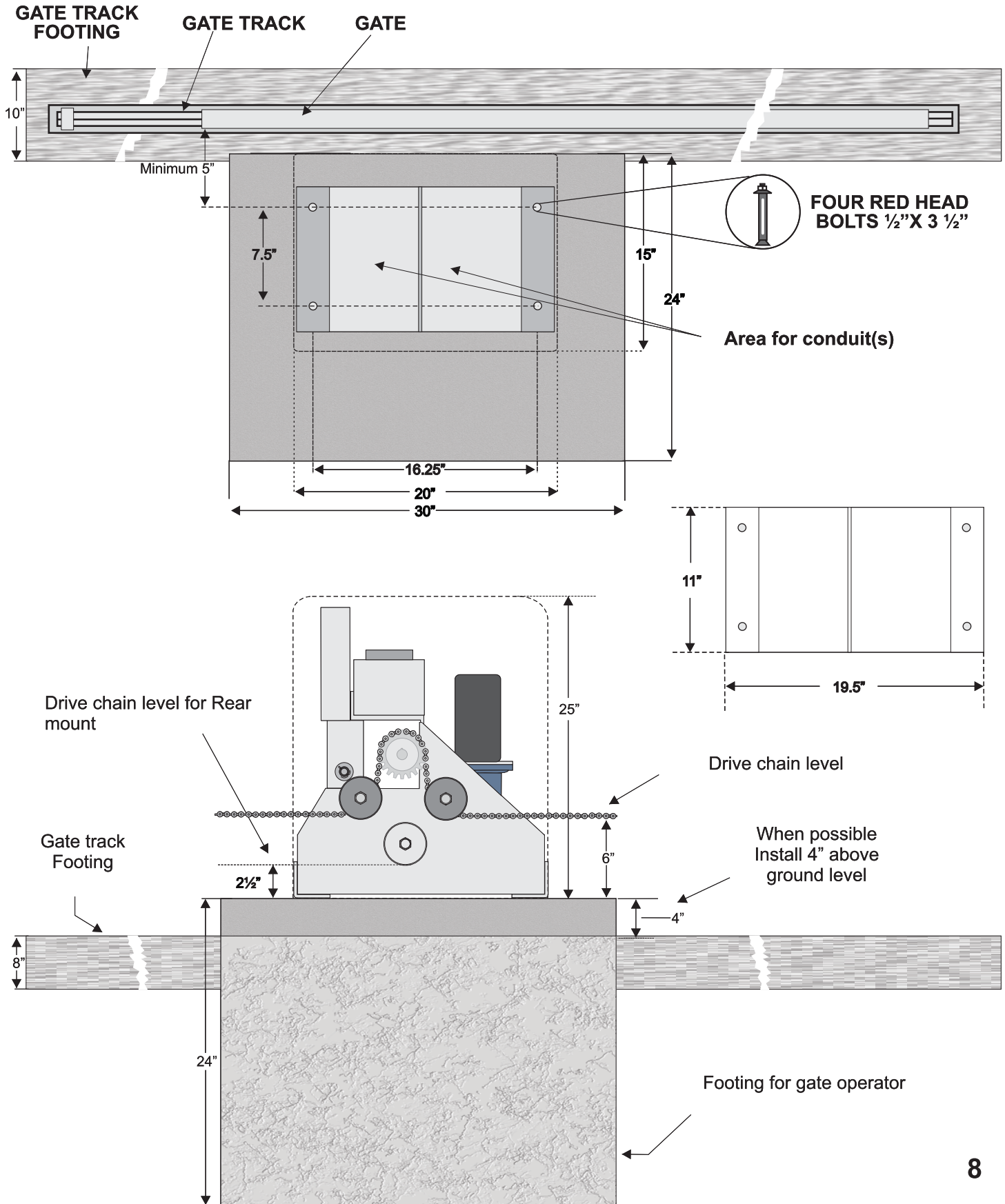

# DIFFERENT INSTALL CONFIGURATIONS

## A front mount installation and chain layout

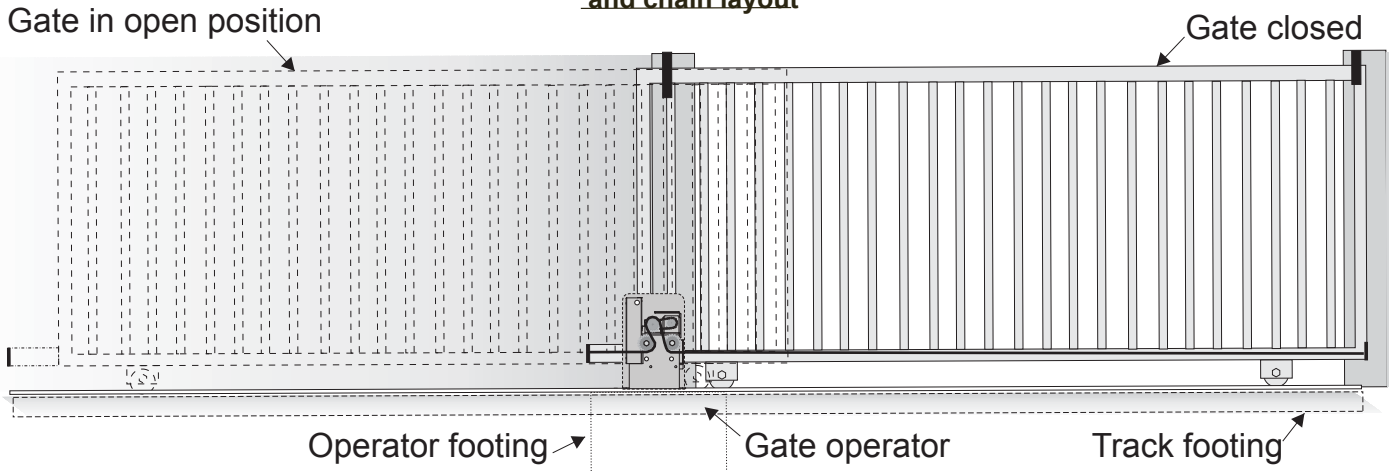

### Overhead View

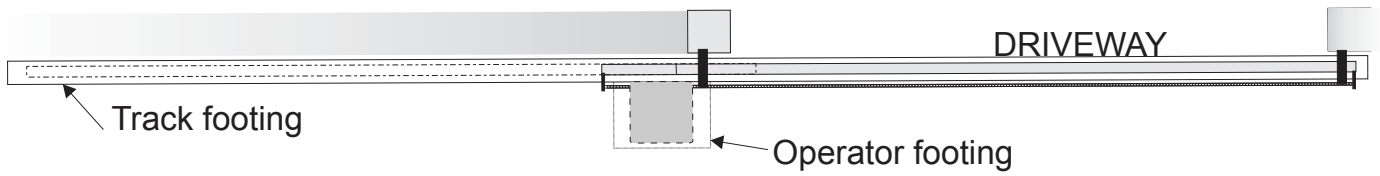

## Rear mount installation and chain layout

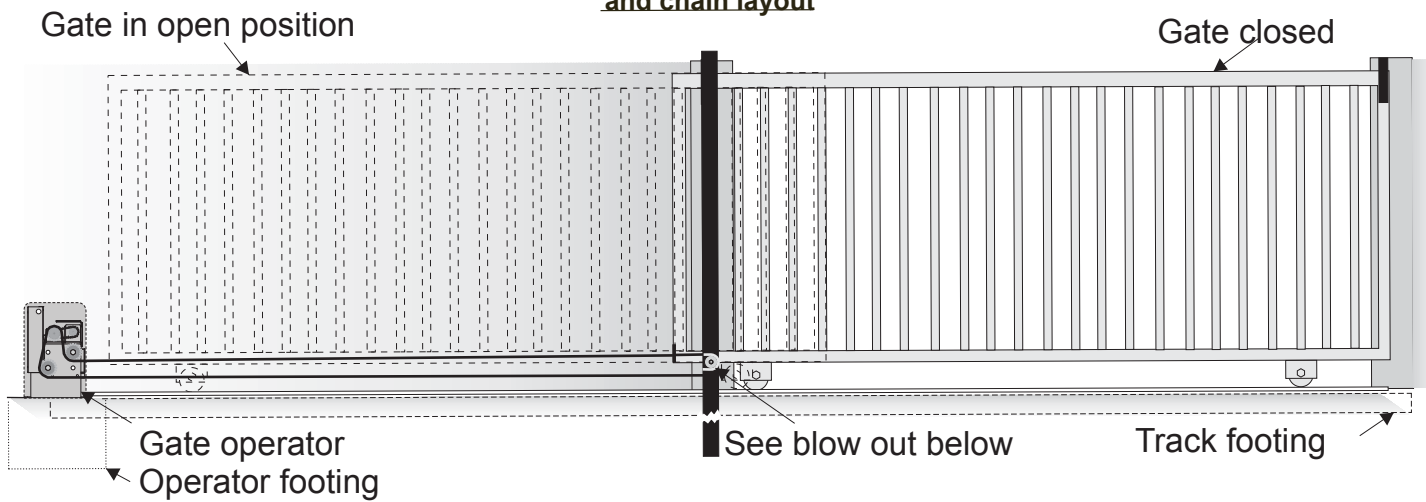

### DRIVEWAY

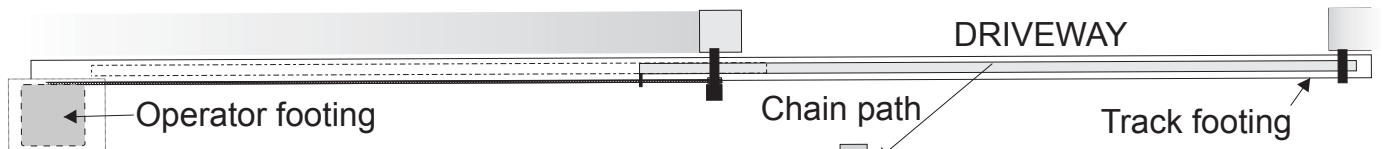

Move one idler to bottom hole and follow chain path as shown.

Gate operator footing

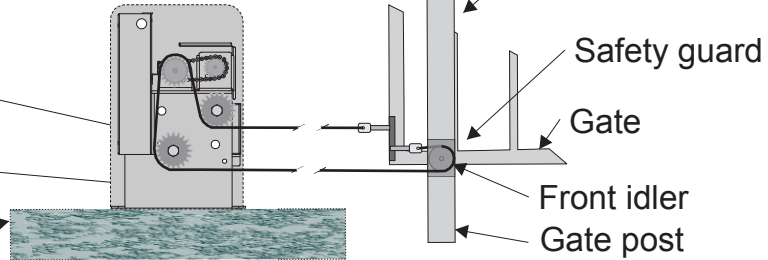

# GATE TRAVEL ADJUSTMENT FOR **SL-45 SL-90 & SL-100DC**

Locate limit switches

Step 1: Stop the gate operator using the three button station on the board.

Step 2: Push limit lock plate down. Turn limit nut in the desired direction.

Step 3: Place limit plate to its locked position.

Step 4: Run gate operator.

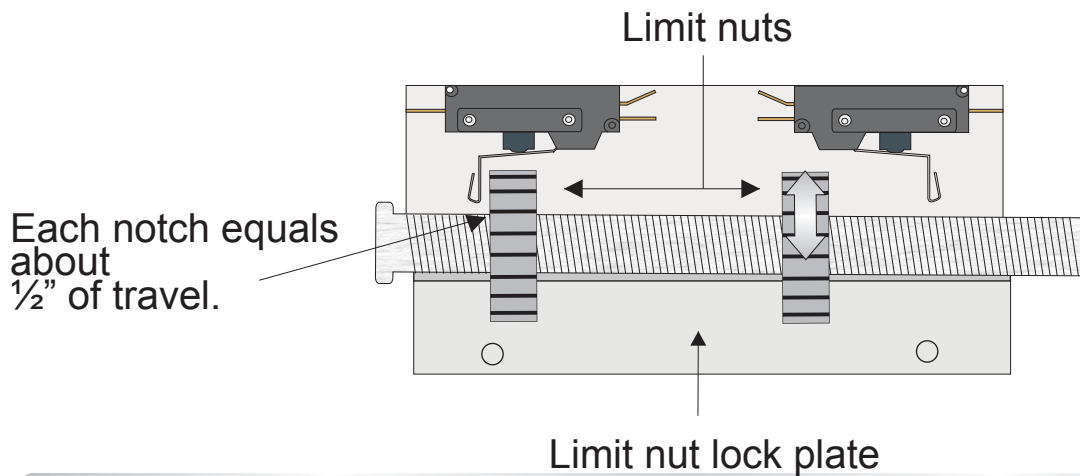

# ADJUSTMENT FOR **SL-150DC**

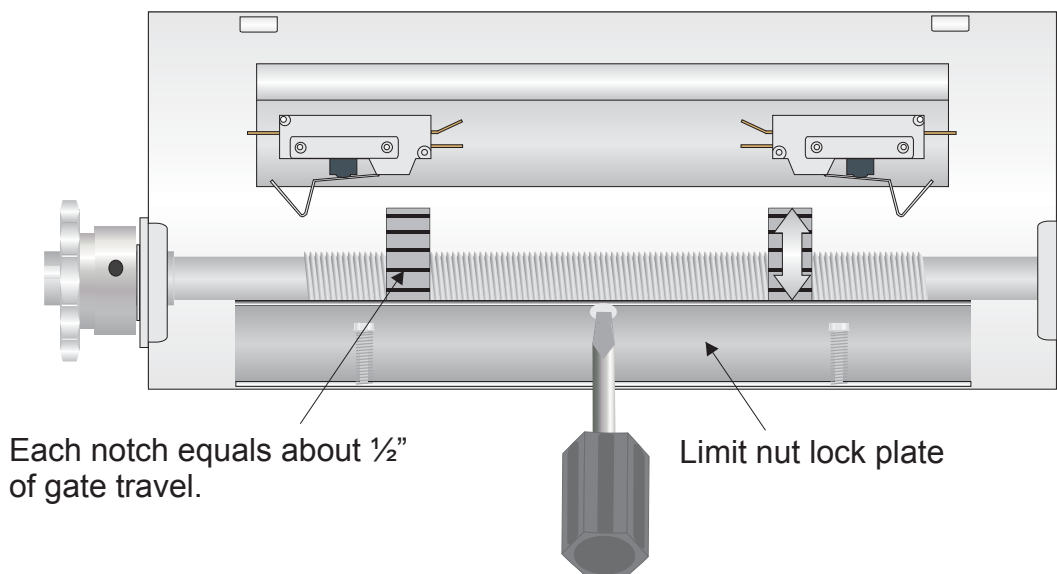

Limit plate must be tight in limit nut slots for gate to hold it's limits.

# OPENING DIRECTION SETTINGS

Use **OPEN L/R** dipswitch to change the opening direction on the operator. **OFF** for left hand opening, **ON** for right hand opening.

LED's will show opening or closing directions when gate is running.

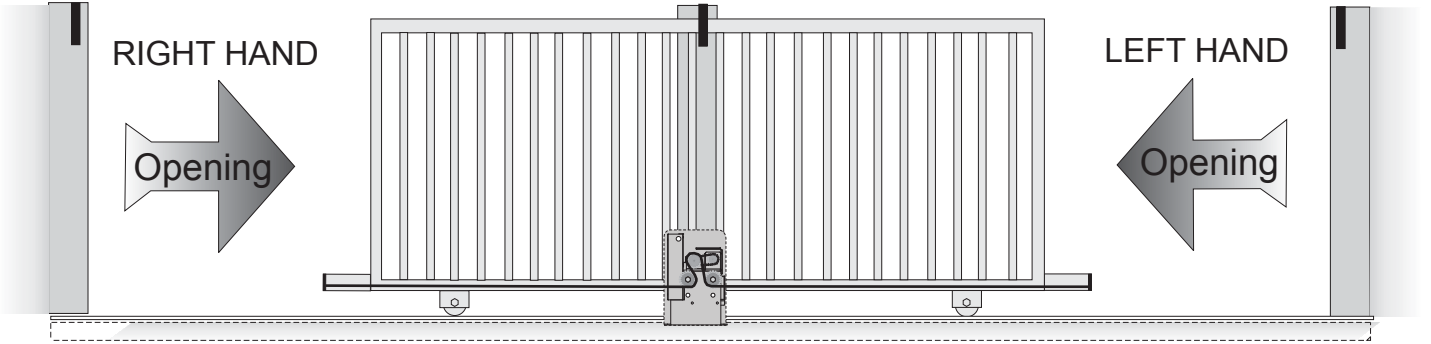
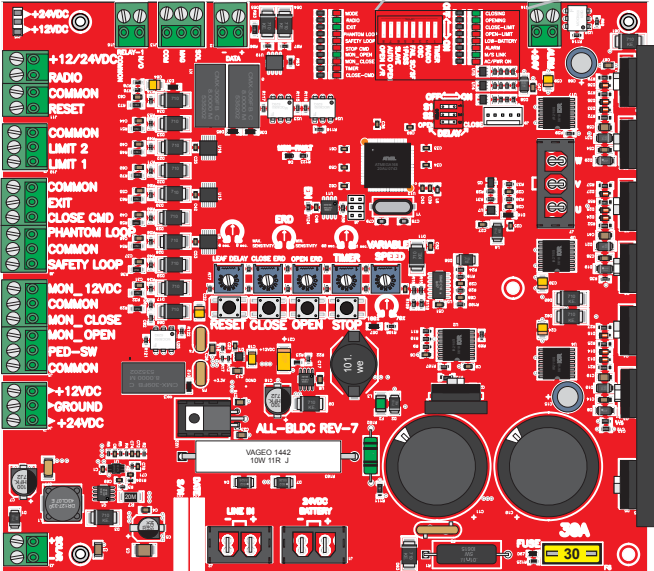
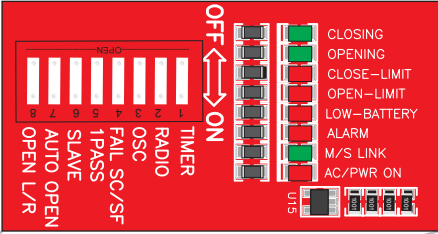

Right hand and left hand opening is from behind the operator.

# ELECTRICAL CONNECTION

**OPERATORS MUST BE PROPERLY GROUNDED!**

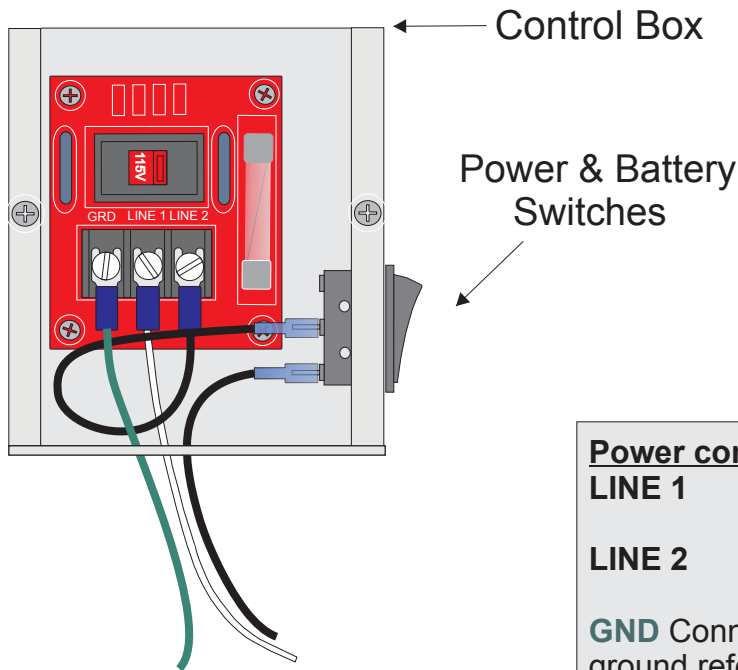

**NOTE:** When applying 230V to operator make sure voltage switch is flipped to 230V position.

| Power connection |   | 115VAC   | 220VAC Single Phase |
|------------------|---|----------|---------------------|
| LINE 1           | = | 115V HOT | 220V LINE 1         |
| LINE 2           | = | 115V N   | 220V LINE 2         |

**GND** Connect to ground. Use a proper **ground rod** for a ground reference.

Use the shortest and thickest wire possible for ground.

For power, a minimum of a **20-Amp** dedicated circuit breaker is needed.

**For power wire enclosure use UL listed conduits.**

All gate operators **MUST** be properly grounded.

A proper ground in a gate operator installation minimizes or prevents damage from an electrical charge, such as a near lightning strike or an electrical static discharge.

Use a single wire for the ground. **DO NOT** splice two wires for the ground. If the wire breaks or is cut, replace it with a single length. **NEVER** use two wires for the ground.

Check with your City code for proper earth ground rod type and proper grounding procedures.

# TYPICAL LOOP LAYOUT

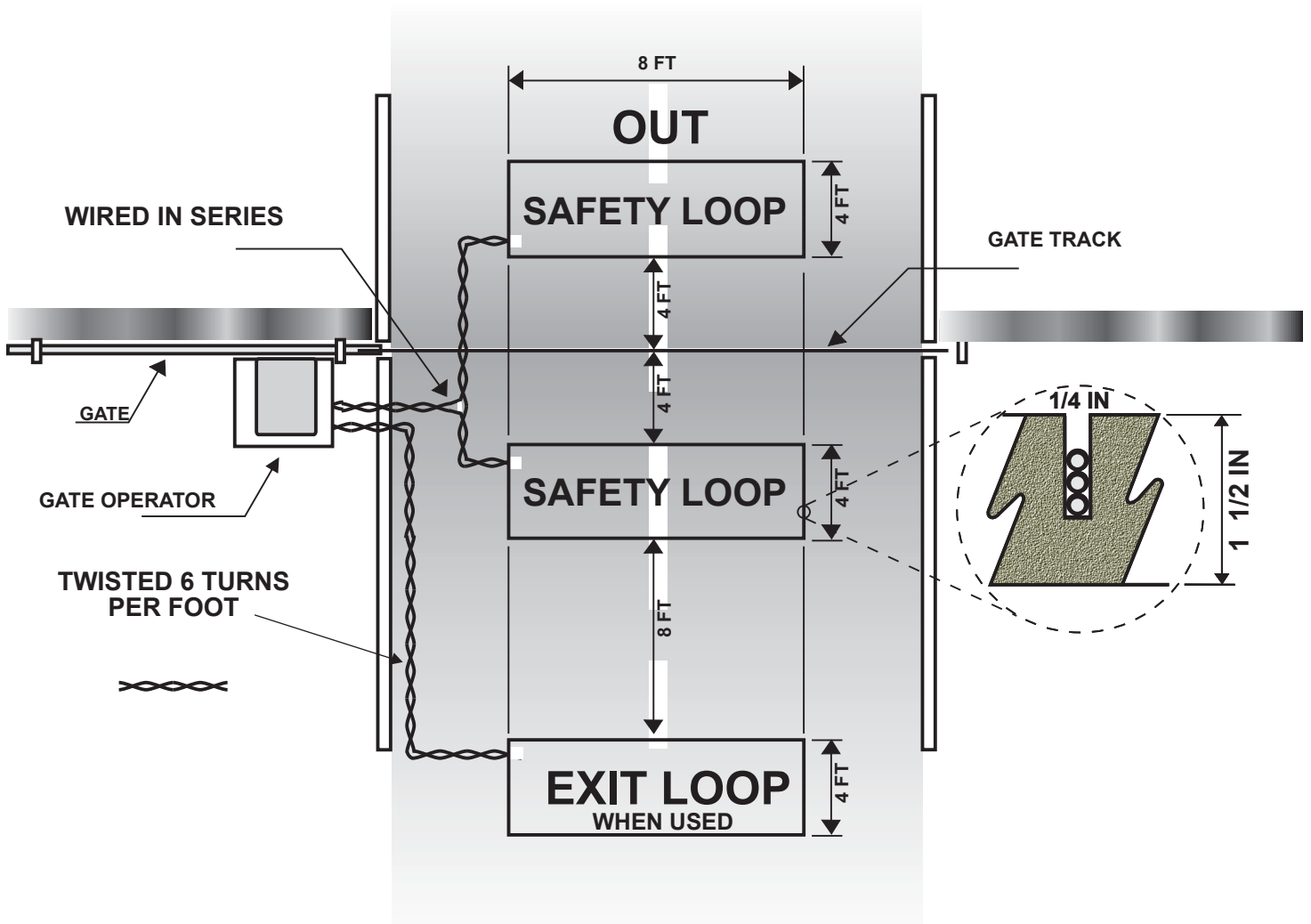

This is a normal loop layout. Remember when connecting to an All-O-Matic circuit board you use the **normally closed contacts** for your safety loop detector and **normally open contacts** from the exit loop. You must twist your wires from your exit point of the saw cut all the way to the circuit board, no exceptions.

# GENERAL LOOP INSTALLATION GUIDELINES

The following loop installation guidelines are for installing typical driveway loops for access control applications (i.e. parking gates, sliding gates, swing gates etc...) Always consult with loop detector manufacturers for specific equipment guidelines. This will confirm that the proper configuration and installation techniques are properly applied for your application.

Useful information about inductive loops:

- A. The typical sensing height is 2/3 of the shortest leg of loop (in feet)  
Therefore a 4' x 8' loop typically has a detection height of 2.6'.
- B. The inductance of a conventional four-side loop can be estimated using the formula:

$$L = P \times (T^2 + T) / 4$$

Where L = Loop Inductance in microHenries  
P = Loop Perimeter in feet  
T = Number of turns of wire in saw slot

Therefore a 4' x 8' loop with 3 turns would be:

$$L = (4 + 8 + 4 + 8) \times (3^2 + 3) / 4$$

$$L = 24 \times (9 + 3) / 4$$

$$L = 24 \times 12 / 4$$

$$L = 24 \times 3$$

$$L = 72 \text{ microHenries}$$

Suggested guidelines for loop installation:

Loop wires should be twisted 6 turns per foot, and twisted from saw slot to the detector. If possible start twisting the wires from the edge of the loop.

All 90 degree corners should be chamfered so that the course of the wire does not change direction sharply but rather at shallower angles of 45 degrees or less. Core drilling of the corners achieves the same effect but can still lead to failure due to sharp edges remaining in the corner area.

| Loop Perimeter | # of Turns |
|----------------|------------|
| 6' - 12'       | 6          |
| 13' - 20'      | 5          |
| 21' - 60'      | 4          |
| 61' - 240"     | 3          |
| 241 & Up       | 2          |

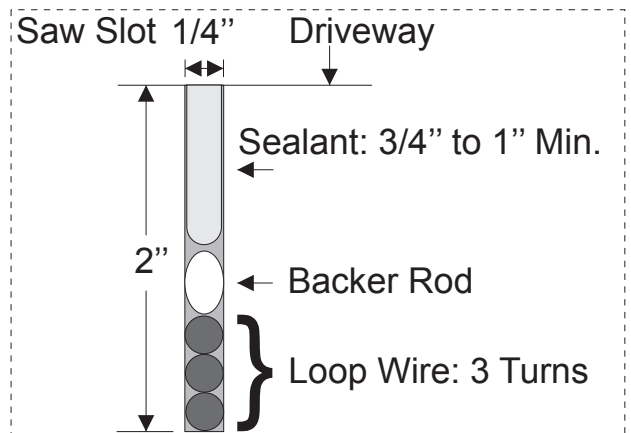
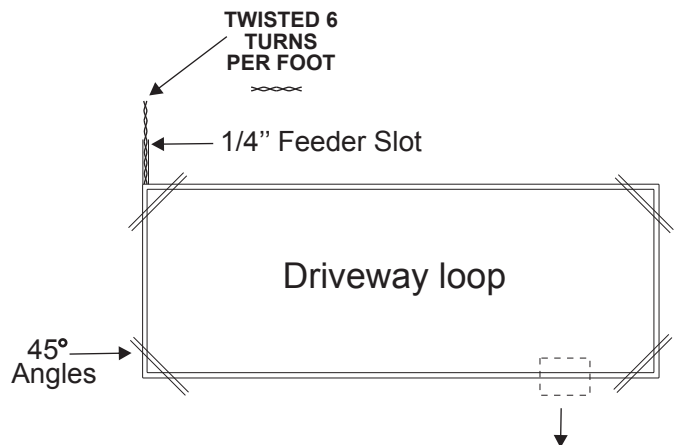



# ACCESSORY CONNECTIONS

The circuit board **12 & 24VDC** outputs provide up to **500mAmps** each input of power for accessories. More than two or three accessories will require a separate power supply.

**NOTE:** 12 & 24VDC Accessories only.

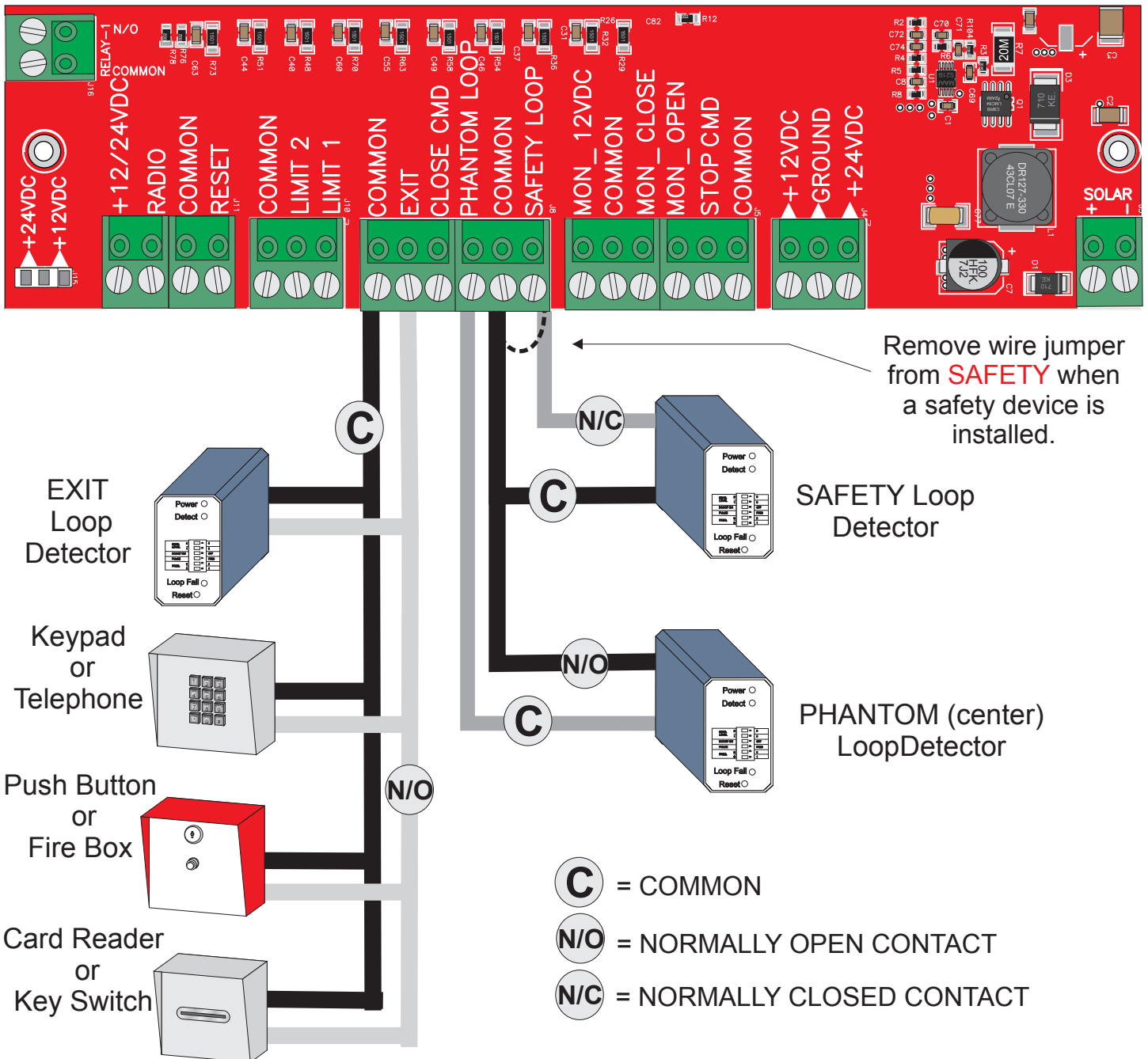



# LPR-1 LOOP RACK INSATALLATION

This is a **typical** loop configuration for a gated driveway. Remember when connecting to an All-O-Matic circuit board the safety (reverse) uses **normally closed contacts** from the loop detector, the wire jumper from the safety connector needs to be removed when a safety loop is inatalled.

You must twist your wires from your exit point of the saw cut all the way to the loop detectors, no exceptions.

**Not Included on SL-45DC**

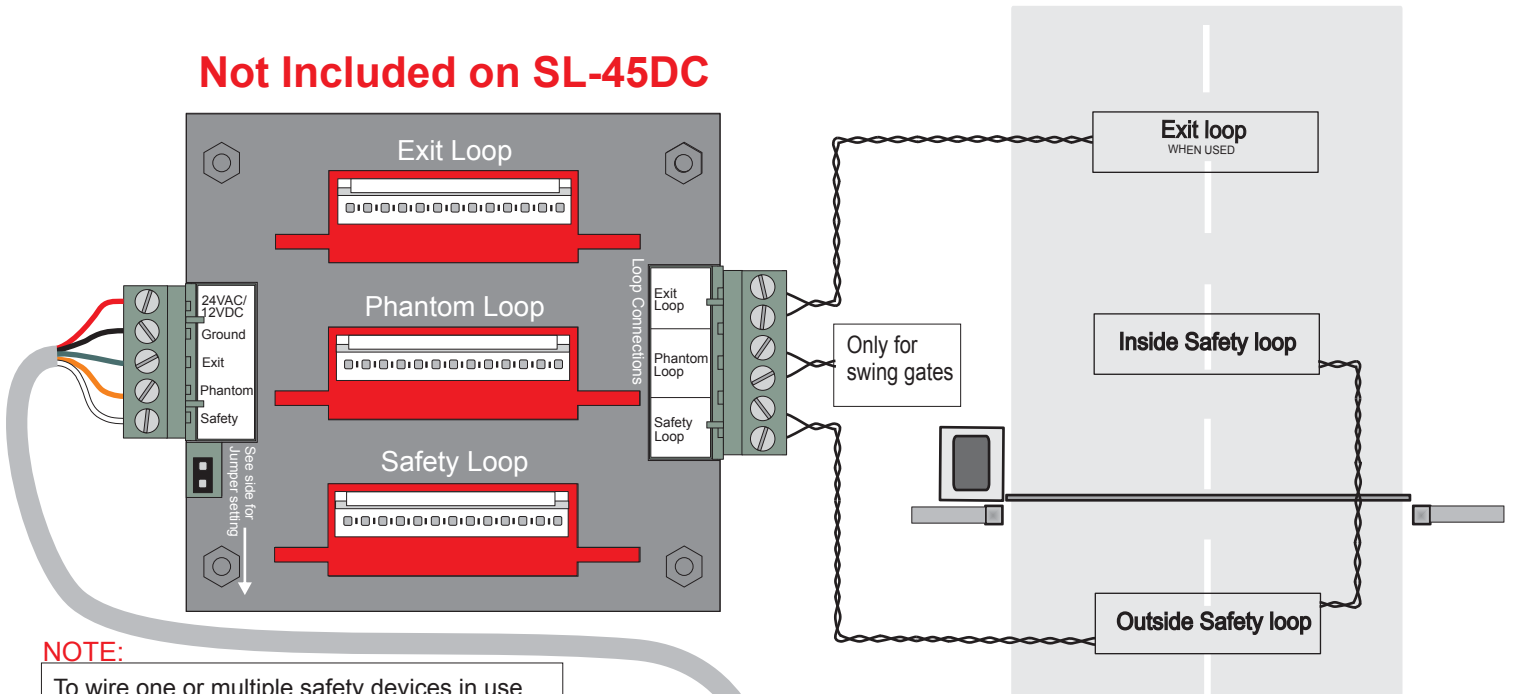

**NOTE:**

To wire one or multiple safety devices in use with loop rack safety device remove loop rack safety white contact wire (N.C.) From safety pin connector on circuit board and wire in Series with added safety devices using the (N.C.) Contact wire from your safety device in the safety contact.

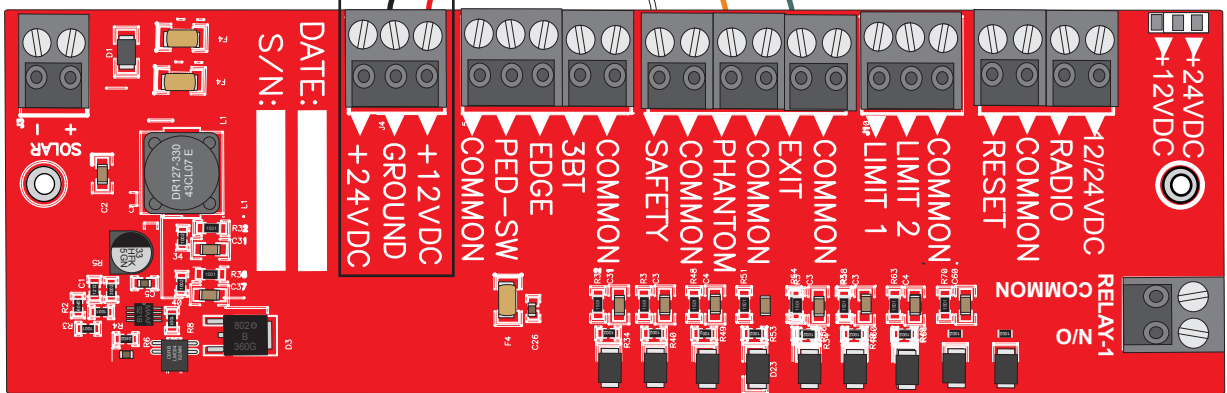

### Compatible Detectors

| Brand           | Model No.   | Jumper setting                         |
|-----------------|-------------|--|
| Reno A&E        | H2          | <input type="checkbox"/> OFF           |
| EDI             | LMA-1500-LP | <input type="checkbox"/> OFF           |
| Diablo Controls | DSP-40S     | <input checked="" type="checkbox"/> ON |

# THREE BUTTON STATION SYSTEM

See push button connections below.

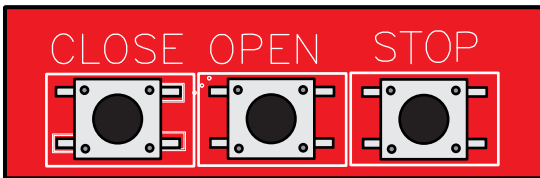

A three button station was integrated on the board to make adjustments easier when setting limit switches and adjusting ERDs.

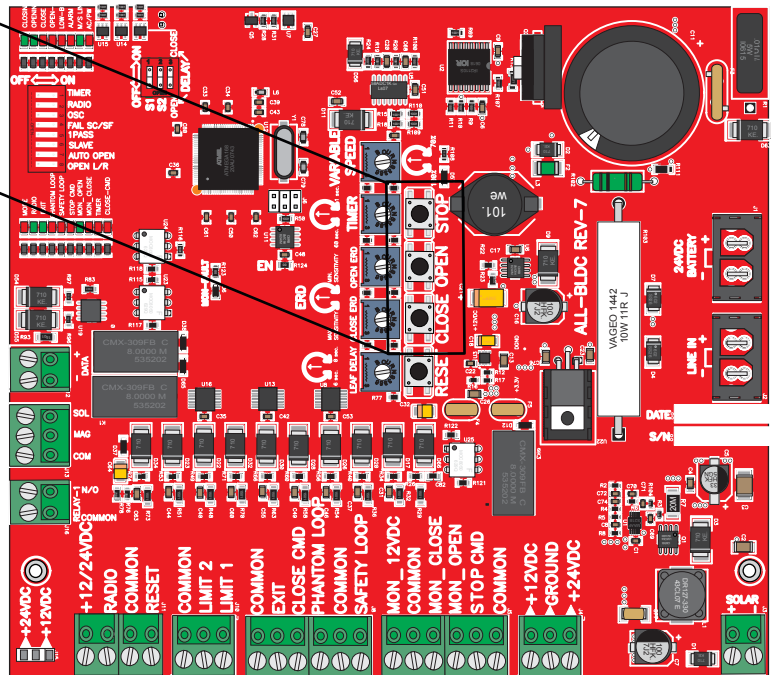

Connect the **COMMON** from all the push buttons to **COMMON** input on the board.

Connect **OPEN** push button **N.O.** contact to **EXIT** input on the board.

Connect **CLOSE** push button **N.O.** contact to **3BT** input on the board.

Connect **STOP** push button **N.C.** Contact to **STOP CMD** input on the board and remove **STOP CMD** jumper.

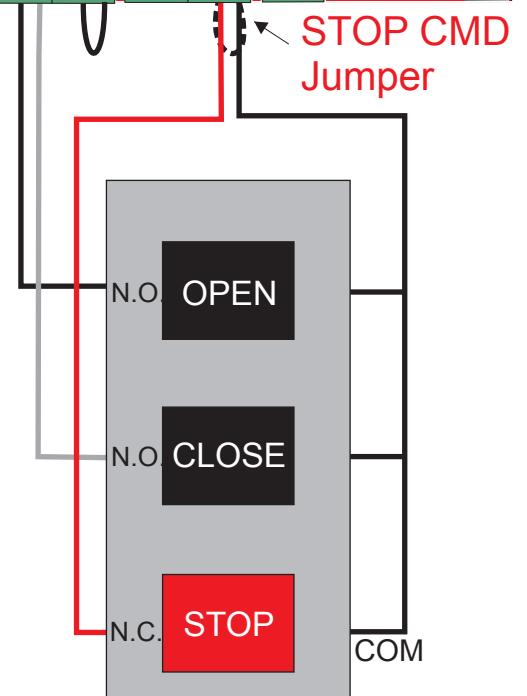

# ENTRAPMENT PROTECTION INSTALLATION FOR SLIDING GATES

A minimum of two monitored entrapment protection devices are **required** for each entrapment zone. All locations or point of contact where a person can become entrapped between a moving gate and a rigid object is considered an entrapment zone. The operator has an inherent entrapment protection (ERD) system. It requires an external monitored entrapment protection device (contact edge sensor or non-contact photoelectric sensor) for each entrapment zone prior to gate operation. The operator cycles power to the external entrapment protection device and checks for device signals. If the operator does not receive the correct feedback from the device, the gate will not operate.

Below are some samples of entrapment zones and where the entrapment protection devices should be installed.

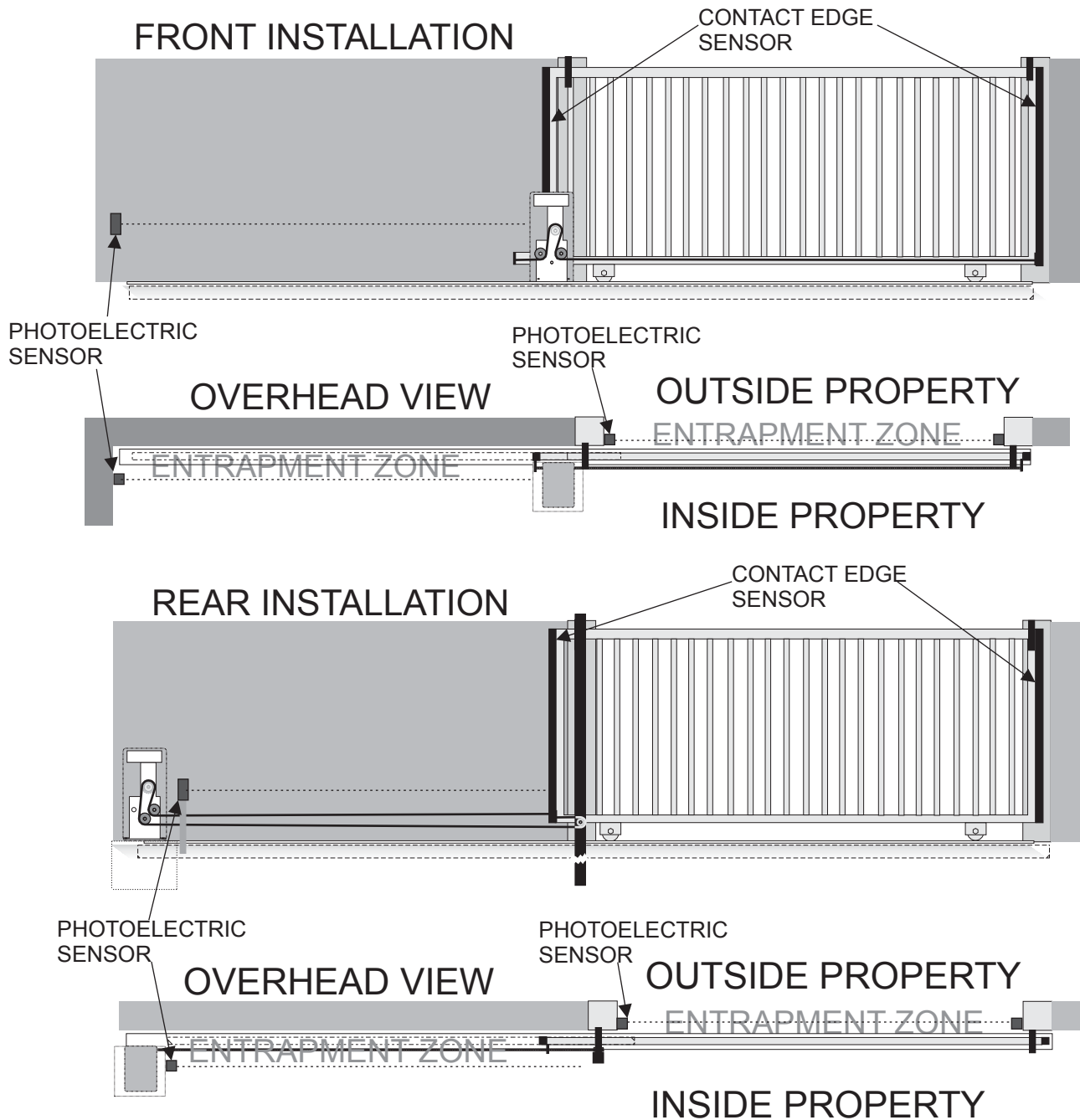

# ENTRAPMENT PROTECTION DEVICE CONNECTIONS

There are two type of entrapment protection devices that can be connected to the operator, NON-CONTACT SENSOR (PHOTO EYE) and CONTACT SENSOR (EDGE SENSORS). These inputs are for monitored ENTRAPMENT PROTECTION devices.

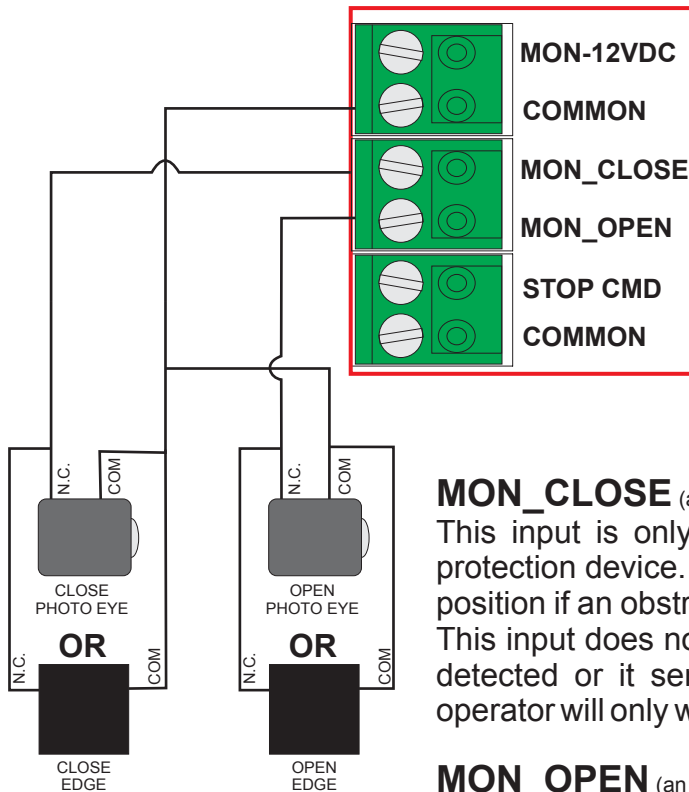

Wiring for brushless DC gate operators.

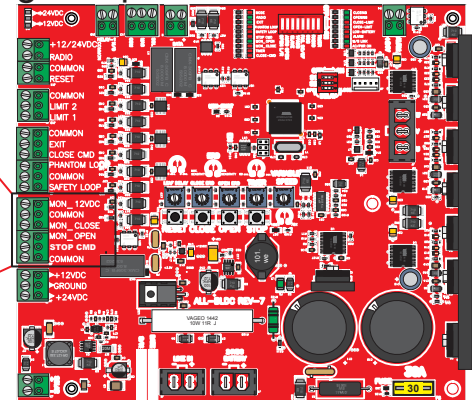

PCB model: ALL-BLDC

**MON\_CLOSE** (an LED will indicate when an obstruction is detected or device not present)  
This input is only for the close direction monitored entrapment protection device. When gate is closing it will open to the full open position if an obstruction is sensed and resets the auto close timer. This input does nothing in the opening direction. If a device is not detected or it senses a fault (**MON\_FAULT** LED will turn ON), the operator will only work on constant pressure actuated switch.

**MON\_OPEN** (an LED will indicate when an obstruction is detected or device not present)  
This input is only for the open direction monitored entrapment protection device. When gate is opening it will reverse 2 seconds and stop if an obstruction is sensed. This input does nothing in the closing direction. On power up, if a device presence is not detected the operator will assume one is not required for opening direction. If a device is connected and board detects a fault (**MON\_FAULT** LED will turn ON), the operator will only work on constant pressure actuated switch.

Monitored entrapment protection devices use four wires to connect to the board. From the device, connect **relay common** to board **COMMON** and **N.C.** relay contact to assigned **MON\_OPEN** or **MON\_CLOSE** input. Connect the power wires to the **COMMON** and **MON-12VDC**. **VERY IMPORTANT:** The **MON-12VDC** supply must be used (not the normal 12VDC terminal) to properly monitor entrapment protection devices.

Refer to the device manufacturer wiring instructions for details. Be sure to follow the **N.C.** directions. Some devices may work on different monitoring interfaces as well as the **N.C.**.

Should there be a need for more than one entrapment protection device for each direction, a multi-input module from Miller Edge Model: MIM-62 (not included) may be used.

# MASTER/SLAVE CONNECTION

Before connecting master/slave gate operators together, test and adjust the limit switches and the ERDs for each operator as “stand alone” machines. All accessories must be installed on the master board, no exception.

See page 26 for dip switch settings.

Use a two wire **shielded cable** and run it through a UL listed conduit for master/slave connection. Follow the wiring diagram as shown below.

Master Board

Slave Board

+ ..... Positive to Positive ..... +

- ..... Negative to Negative ..... -

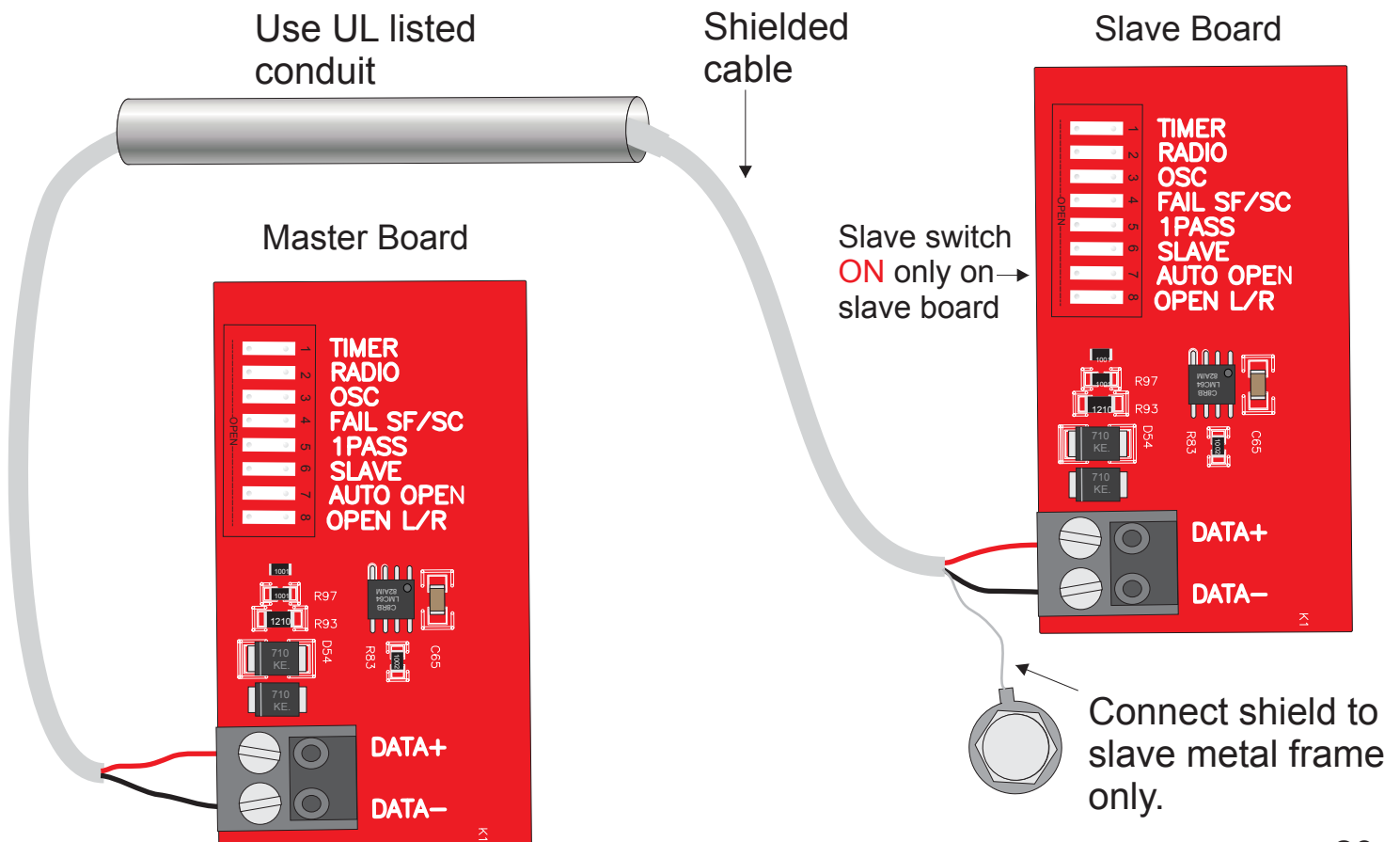

# MAGNETIC/SOLENOID LOCK CONNECTIONS

Magnetic lock installation requires a step down transformer with appropriate voltage for the specific lock accessory. Operator will provide a 120VAC outlet for the step down transformer.

**Connections:** Plug the lock device transformer to the 120VAC outlet plug.

**For Magnetic lock:** Connect one wire from transformer directly to one wire of the magnetic lock, the other wire from transformer will be connected to the relay plug **COM** input and the **MAG** relay output connects to the other wire of the magnetic lock. See illustration below.

**For Solenoid lock:** Connect one wire from transformer directly to one wire of the solenoid lock, connect the other wire from transformer to the relay plug **COM** input and the **SOL** relay output connects to the other wire of the solenoid lock. See illustration below.

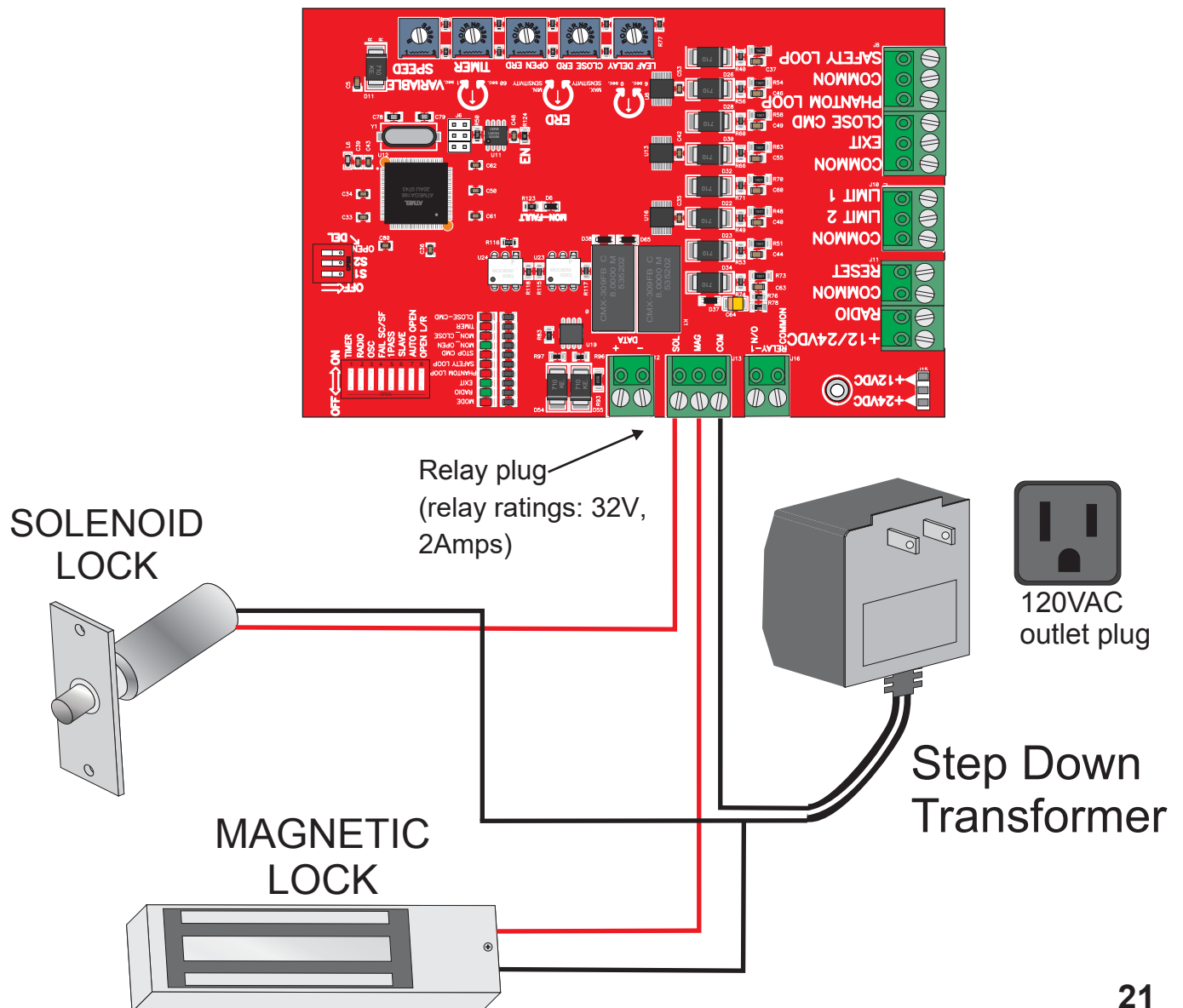

# RADIO RECEIVER CONNECTIONS

**4 wire receiver:** connect the two relay wires to 1 & 2 terminals. Black **negative** wire to terminal 1 and Red **positive** wire to terminal 3 on receiver strip outside control box as shown below.

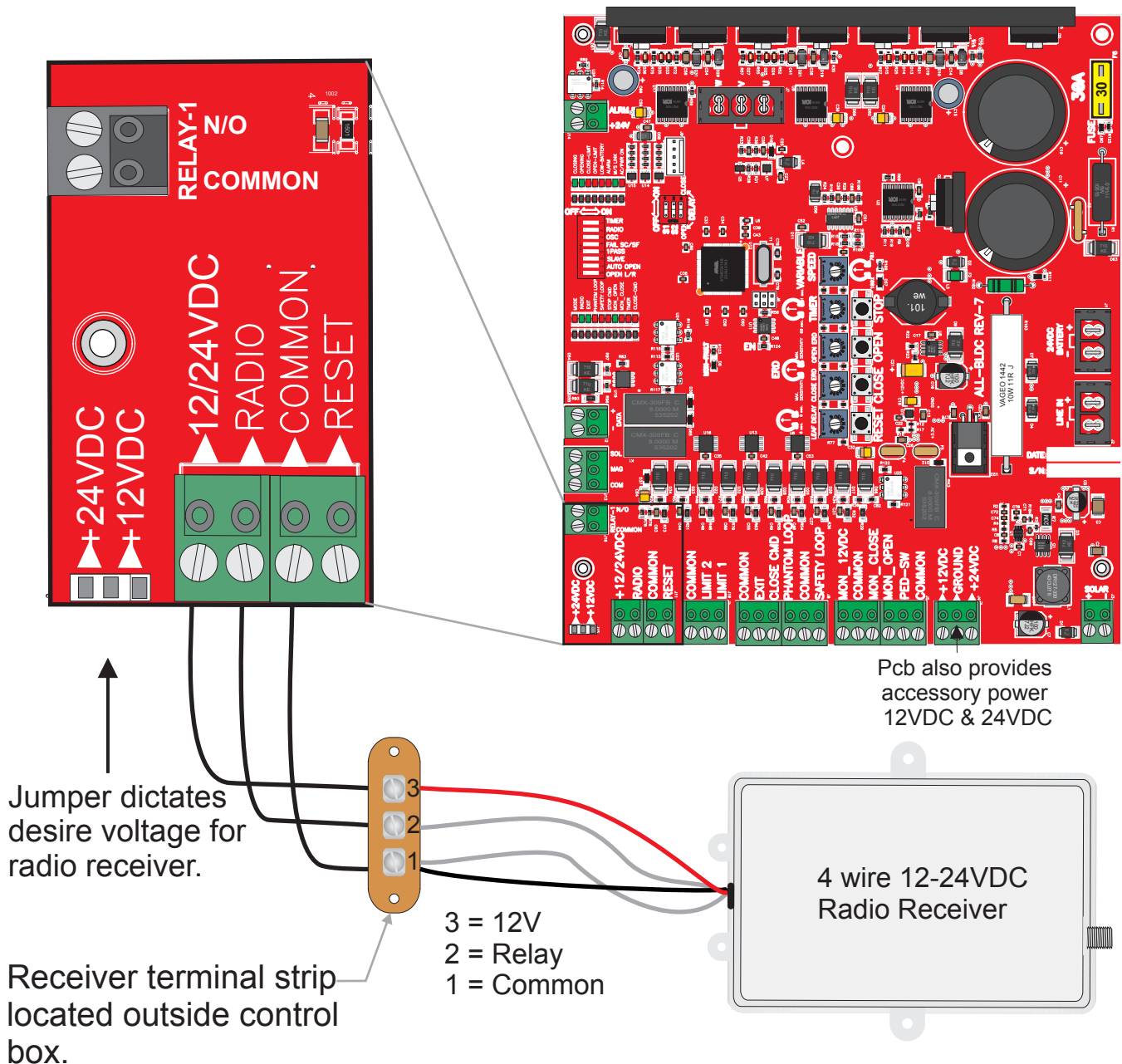



# OPEN AND CLOSE ELECTRONIC REVERSING SENSOR(ERDs) ADJUSTMENT

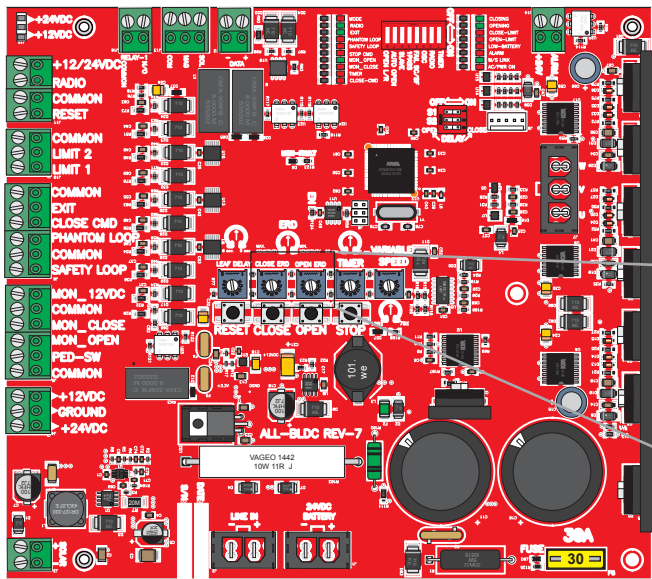

Open and Close ERD SENSITIVITY

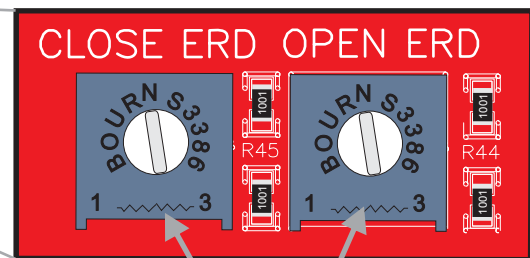
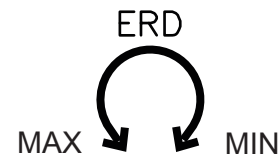

ERD'S must be adjusted by qualified technician.

The gate operator ERDs must be adjusted so that the gate provides regular, reliable and safe cycles.

ERD must be checked every six months.



Counter clockwise maximum sensitivity



Clockwise minimum sensitivity

When gate stops and reverses by itself, the ERD is **too sensitive**.

The gate must stop and reverse when it hits an obstruction or the ERD is **not sensitive enough**.

# TIMER ADJUSTMENT

TIMER ON: Timer to close, can be set from 1 to 60 seconds.

TIMER OFF: Gate operation is push button to open, push button to close.

TO OVERRIDE THE TIMER: Turn the RADIO switch to the "ON" position. This will allow the radio receiver to close the gate before the timer.

## TIMER ADJUSTMENT



Turn potentiometer counter clockwise for more time.



Turn potentiometer counter clockwise for less time.

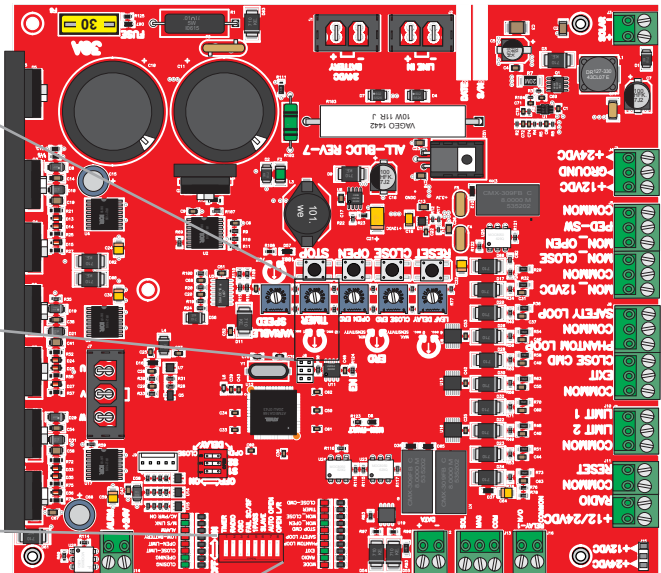
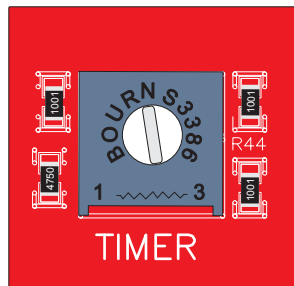

TIMER "ON" to activate the timer

RADIO "ON" = Allows the transmitter to close the gate before the timer.

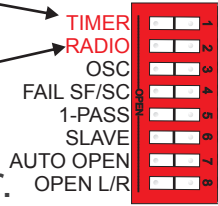

OFF ← ON

# PROGRAMMABLE RELAY & GATE DELAY

The board model **ALL-BLDC** includes a programmable relay with four different configurations.

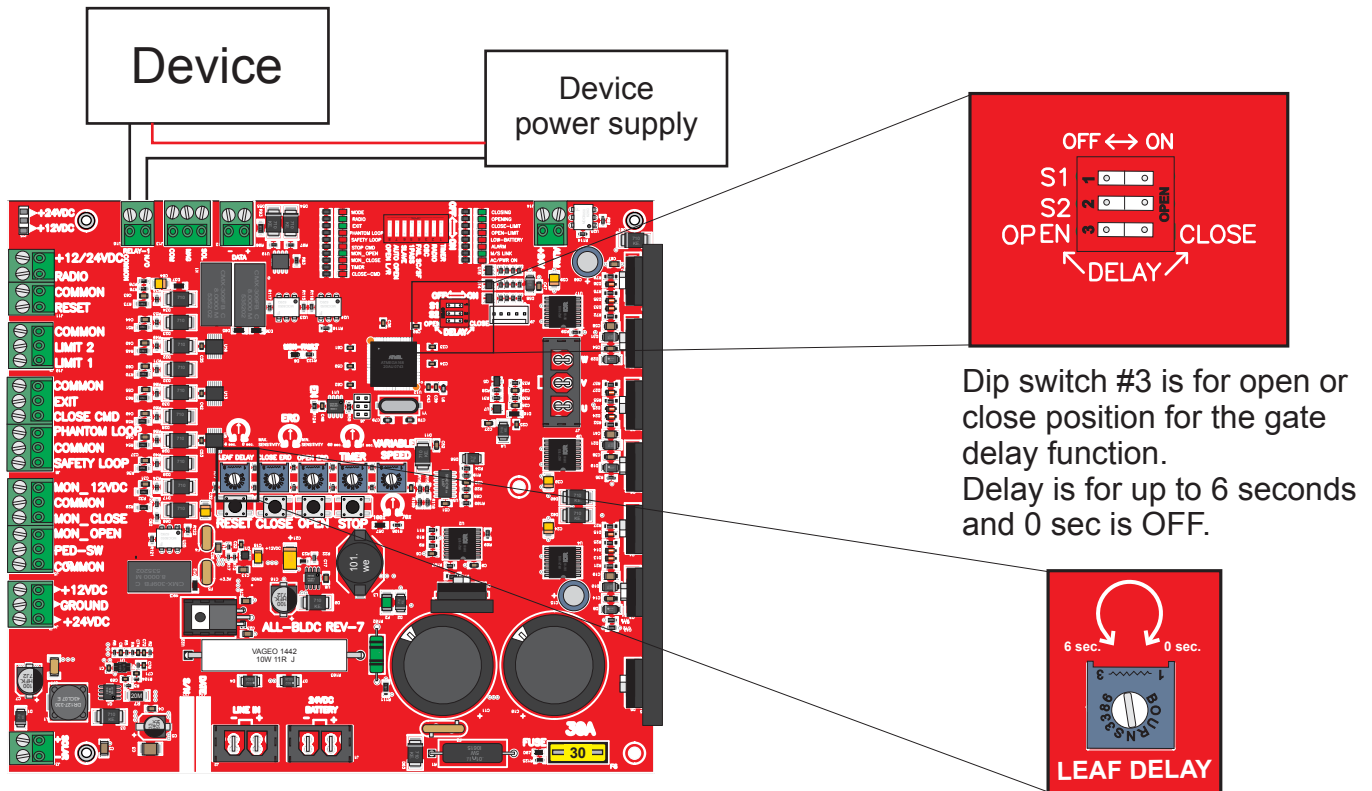

| S1  | S2  | Relay-1 Functions             |
|-----|-----|-------------------------------|
| OFF | OFF | 1 Second pulse in every open  |
| ON  | OFF | On when gate is in motion     |
| OFF | ON  | Alarm system output           |
| ON  | ON  | On when gate not fully closed |

The 1 second pulse is normally used for a cycle counter.

The “On” when gate is in motion is used for an audible alarm or a strobe light to warn when gate is in motion.

The “Alarm System” output will activate the relay whenever the gate is forced open (without access device).

The last function is for a gate status. It activates the relay when gate is not fully closed.

# DIP SWITCH FUNCTIONS

**NOTE:** Any changes to dip switches while power is **ON** requires you to reset the processor in order for board to read the change.

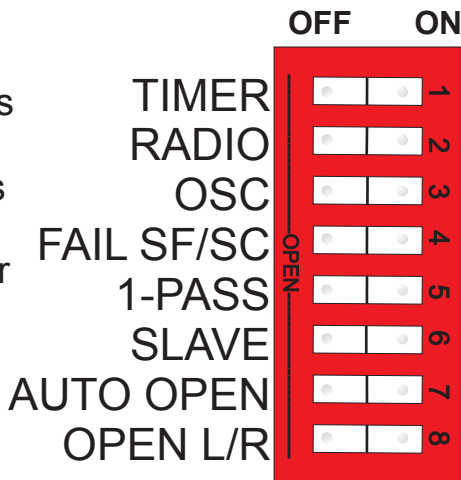
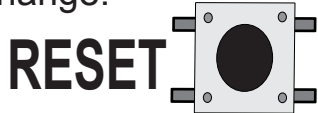

## TIMER

**TIMER** switch “ON” activates the TIMER. See page 24 for details

## RADIO

**RADIO** switch “ON” allows the radio receiver to override the timer. See page 24 for details.

## OSC

**OSC** switch ON allows the radio receiver to stop and reverse the gate in any direction. During a cycle the first signal stops gate a second signal reverses gate.

## FAIL SF/SC

This is to set the operator as fail-safe or fail secure. **ON** for **Fail-safe**: on power failure, board will monitor battery voltage to make sure gate opens before battery drains out completely. **OFF** for **Fail-secure**: on power failure gate will run until battery is low and stay close.

## 1-PASS

This is a true one pass, anti-tailgating feature. This feature may only be used with safety loops. With this switch in the “ON” position, the gate will open until one car passes the safety loops then it will stop and close. If a second car pulls on the loop the gate will stop the car must then back off the loop before the gate will close.

## SLAVE

This feature is used on master/slave setups. Set slave switch “ON” on slave machine, all other switches “OFF”. Set slave switch to the “OFF” position on master machine. Set other function switches on master machine as desired. See page 20 for more details on master/slave connections and settings.

## AUTO OPEN

This feature is to automatically open the gate on power interruption. It is a very particular feature used in areas where the fire department requires the gate to open automatically after a power outage. Set this dip switch “ON” when this feature is desired.

## OPEN L/R

This feature is to set the direction the operator will open. See page 11 for details.

# SOLAR PANEL CONNECTION

The solar panel input will take a 12VDC panel 40W minimum. The charging circuit is limited by 1 Amp max.

When using 24VDC panel up to 40W connect straight into the **LINE IN** input.

For solar installation upgrade batteries according to usage.

**NOTE:** For information on what solar panels, batteries and type of installation call ALL O MATIC for Assistance.

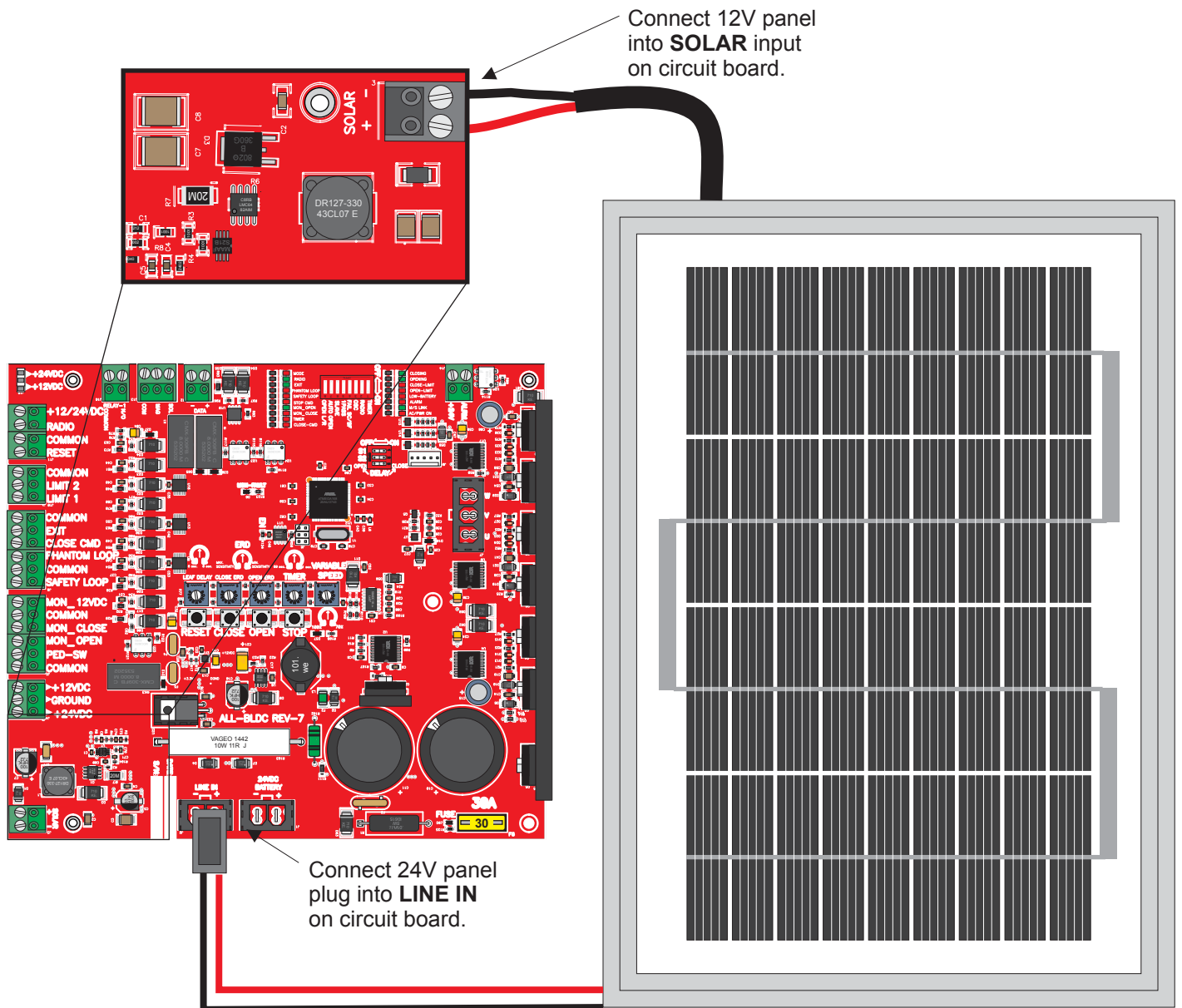

# EXTERNAL SOLAR SYSTEM INSTALLATION

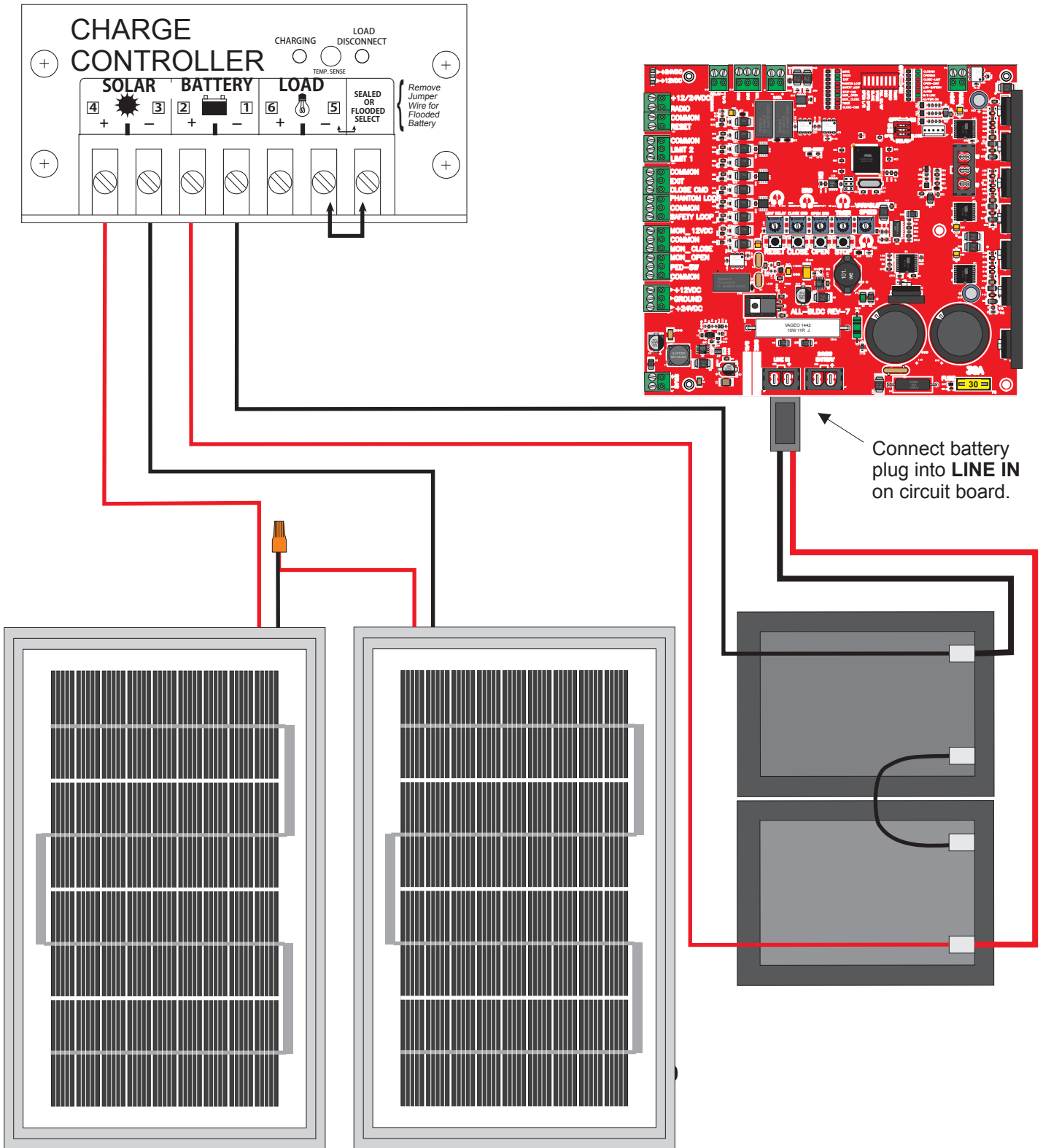

When using External solar package connect straight into the **LINE IN** input. batteries have to be upgraded according to usage.

**NOTE:** For information on what solar panels, batteries and types of installation call ALL O MATIC for Assistance.

# LED DIAGNOSTICS

**AC/PWR ON:** Will be lit when AC power is ON.

**M/S LINK:** Will be lit when master/slave communication is active.

**ALARM:** Two states.

1st state: LED will blink(horn will beep also) every 30 seconds when battery is low, bad or disconnected.

2nd state: LED will turn on for 5 minutes when operator goes on shut down mode do to the gate hitting an obstruction(E.R.D.). Also, the horn will sound for 5 minutes.

**LOW BATTERY:** LED will be on solid when battery is low.

**MODE:** Two states.

1st state: LED will blink slow(about every 2 seconds) when an overload occurs(over current).

2nd state: Will blink fast(abouty every ½ second) when gate is jammed or motor sensors Are not responding or disconnected.

**OPEN-LIMIT:** LED will be on while limit nut is against open limit switch.

**CLOSE-LIMIT:** LED will be on while limit nut is against close limit switch.

**OPENING:** LED will be on while operator is in the open cycle(running open).

**CLOSING:** LED will be on while operator is in the close cycle(running close).

**RADIO:** LED will turn on while radio input is activated(closed circuit to COMMON).

**EXIT:** LED will turn on while EXIT input is activated(closed circuit to COMMON).

**PHANTOM:** LED will turn on while PHANTOM input is activated(closed circuit to COMMON).

**SAFETY:** LED will turn on while SAFETY input is activated(circuit is open from COMMON).

**STOP CMD:** LED will turn on while STOP CMD input is activated(circuit is open from COMMON).

**CLOSE CMD:** LED will turn on while CLOSE CMD input is activated(closed circuit to COMMON).

**MON\_OPEN:** LED will turn on while MON\_OPEN input is activated(open circuit to COMMON) or when a device is not installed.

**MON\_CLOSE:** LED will turn on while MON\_CLOSE input is activated (open circuit to COMMON) or when a device is not installed.

**MON-FAULT:** LED will turn on when a entrapment device (MON\_OPEN or MON\_CLOSE) is not installed or a fault condition has been detected.

**TIMER LED:** LED will blink when timer is counting (on the open position only).

# EMERGENCY RELEASE

## For **SL-45DC**

Procedures to open gate for **SL-45DC**.

1. Remove operator cover.

2. Locate power box, Turn both power and battery switches OFF.

3. Push or pull gate open.





# EMERGENCY RELEASE

## SL-90FP, SL-100FP & SL-150DC

Procedures to open gate for **SL-100DC**.

1. Turn power OFF.
2. Our gear box has a 10 to 1 ratio so it allows you to push gate open.

Procedures to release gate for **SL-150DC,SL-90DCFP & SL-100DCFP**

1. Turn power OFF.
2. Push pedal down & move pedal **slightly to the left to hold pedal down in position.**
3. Push gate open.



# PAD LOCK TABS

Lock tabs are provided in hardware bag on SL-45DC Only.

Remove bolt and install lock tabs for cover securing and pad locking purpose.

Lock kits available for purchase for SL-100 & SL-150AC or DC.

