

iGAZE[®] RE KIT

Transceiver System for Mechanical, 10k Ω , or 8.2k Ω
Resistive Safety Edges



Movable Device
TCO0900



Fixed Device
RCO0900



INSTRUCTION MANUAL
v.5.23.17



TRANSCEIVER SYSTEM FOR SAFETY EDGES

TECHNICAL SPECIFICATIONS

Movable device name	TCCO900
Fixed device name	RCOO900
Frequency	902-928 Mhz
Range of the system in free space	20 m / 60 feet
TCCO9000 power supply	2 x 1.5V batteries (AA)
RCOO900 power supply	12/24 Vac-dc
Battery duration	2 years (normal functioning mode). 5 years (Low Power mode).
Minimum battery level (TCCO900)	1.9V
Compatible safety edges (TCCO900)	Mechanical (N.C. o N.O.) and/or resistive (8.2 kΩ/10kΩ).
Number of outputs (RCOO900)	2
Maximum number of Transmitters for each RCOO900	8 for each device.
Maximum number of safety edges for each output	8 for each relay.
Power draw on RCOO900 (24Vdc)	25mA (standby) 28 mA (one relay engaged) 50mA (two relays engaged)
Resistive Safety Edge (max value)	5kOhm < R < 20KOhm (safety edge OK) R<5KOhm (safety edge in short circuit) R>20KOhm (OPEN safety edge)
Frequency for alternate current (RCOO900)	50-60Hz
Operating Temperature	-10°C to +55°C / 14°F to 131°F

QUICK START GUIDE

BELOW IS THE MOST COMMON INSTALLATION

TCCO900 - Both safety edges are 8.2kΩ or 10kΩ resistive

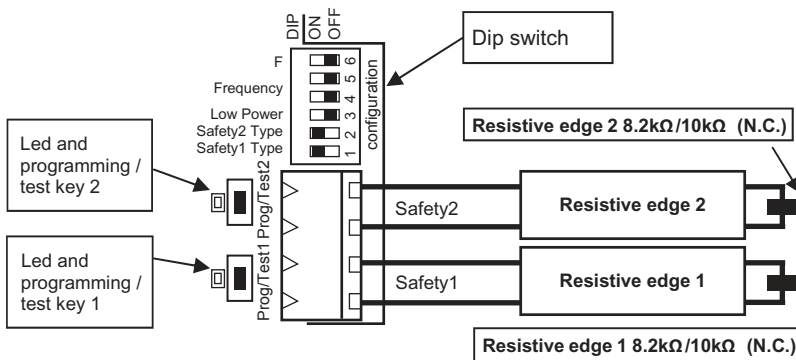

DIP1 ON: resistive safety edge 8.2kΩ/10kΩ 1

If you want to connect a resistive edge on the input Safety1 (8.2kΩ/10kΩ resistor), you must set dip switch 1 to «ON».

DIP2 ON: resistive safety edge 8.2kΩ/10kΩ 2

If you want to connect a resistive edge on the input Safety2 (8.2kΩ/10kΩ resistor), you must set dip switch 2 to «ON».

DIP6: Not Used

RCOO900 - 10kΩ output on both relay 1 and relay 2.

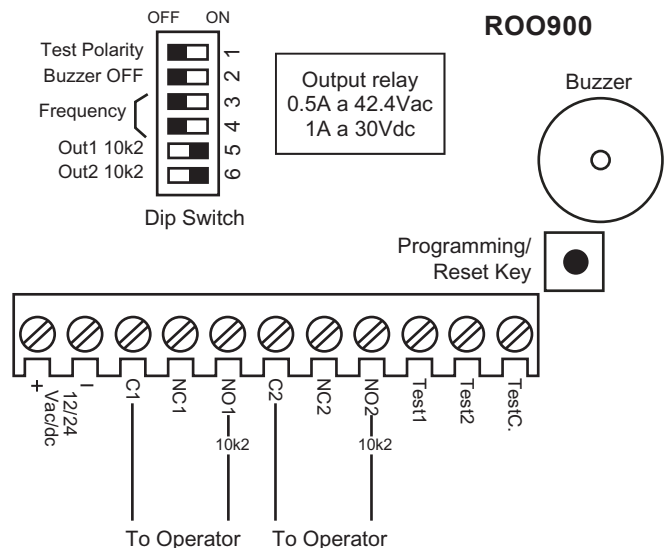

A DESCRIPTION

The iGAZE® RE transceiver system is intended as a safety device for automated gates and rolling doors. The system is comprised of 1 fixed device (RC00900) with 2 output relays, which is connected to the operator, and up to 8 movable devices (TC00900) for each relay. The system TCOO900 will accept safety edges with the following outputs: Mechanical edges with a N.O. or N.C. output, 10kΩ or 8.2kΩ Resistive edges. The fixed device also has 2 controls to perform an “Auto-test” for operators that have this feature. The transmission signal is bi-directional and utilizes the frequencies 902-928MHz. Maximum range between the movable and fixed devices is 60 feet.

TCOO900 is suitable for outdoor use. RCO0900 is suitable for indoor use only (“indoor” means inside the operator box.) The installation of the system must be carried out by a qualified installer.

B CONFIGURATION AND ELECTRICAL CONNECTIONS

STEP 1

CONNECT THE SAFETY EDGE TO THE SAFETY EDGE MOVABLE DEVICE (TCOO900)

It is possible to connect multiple safety edge technologies into each safety edge movable device within certain conditions as shown in *Table 1*.

Table 1

	OPTION 1 <i>Refer to Example 1</i>	OPTION 2	OPTION 3	OPTION 4
SAFETY 1 INPUT	Resistive safety edge 8.2kΩ / 10kΩ	Resistive safety edge 8.2kΩ / 10kΩ	Mechanical safety edge (N.C./N.O.)	Mechanical safety edge (N.C./N.O.)
SAFETY 2 INPUT	Resistive safety edge 8.2kΩ / 10kΩ	Mechanical safety edge (N.C./N.O.)	Resistive safety edge 8.2kΩ / 10kΩ	Mechanical safety edge (N.C./N.O.)

WARNING: If you use mechanical safety edges, both safety edges must be configured the same with either a normally open contact, or a normally closed contact.

STEP 2

SET THE DIP SWITCHES OF THE TCOO900 TO CORRESPOND TO THE EDGE CONFIGURATION YOU HAVE CHOSEN ACCORDING TO THE CONDITIONS OF TABLE 1 AND PER THE FOLLOWING EXAMPLES:

TCOO900

DIP

ON

OFF

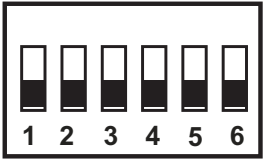

N° DIP	Function
1	Mechanical (OFF) or resistive (ON) edge 1.
2	Mechanical (OFF) or resistive (ON) edge 2.
3	Low Power. (see Section E on page 11)
4	Frequency channel selection (see page 6)
5	
6	Mechanical edge with N.C. contact (OFF) or Mechanical edge with N.O. contact (ON)

(All switches in example above are set to OFF)

EXAMPLE 1 - Both safety edges are 8.2kΩ or 10kΩ resistive (MOST COMMON INSTALLATION)

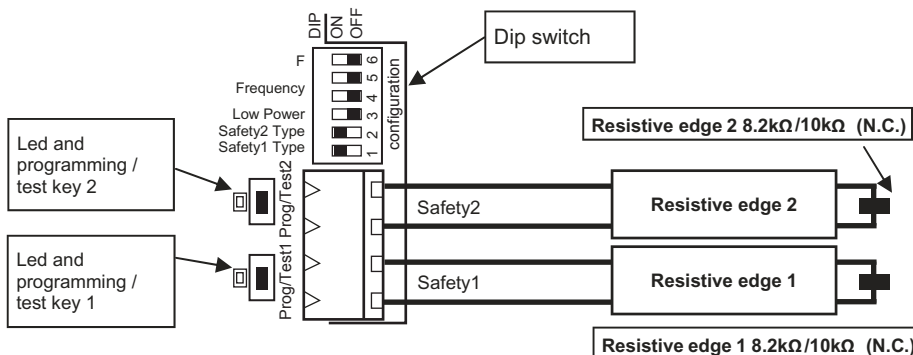

DIP1 ON: resistive safety edge 8.2kΩ/10kΩ 1
If you want to connect a resistive edge on the input Safety1 (8.2kΩ/10kΩ resistor), you must set dip switch 1 to «ON».

DIP2 ON: resistive safety edge 8.2kΩ/10kΩ 2
If you want to connect a resistive edge on the input Safety2 (8.2kΩ/10kΩ resistor), you must set dip switch 2 to «ON».

DIP6: Not Used

EXAMPLE 2 - Both safety edges are normally closed.

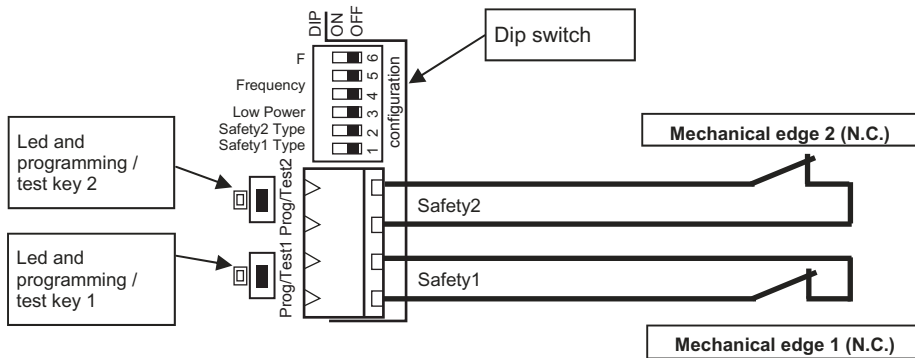

DIP1 OFF: mechanical safety edge 1
If you want to connect a mechanical edge on the input Safety1 (normally closed contact), you must set dip switch 1 to «OFF».

DIP2 OFF: mechanical safety edge 2
If you want to connect a mechanical edge on the input Safety2 (normally closed contact), you must set dip switch 2 to «OFF».

DIP6 OFF: mechanical safety edge N.C.
If you want to use a mechanical safety edge with a normally closed contact, you must set dip switch 6 to «OFF».

EXAMPLE 3 - Both safety edges are normally open.

Warning: This configuration does not meet the current UL-325-2016 standard, but is accepted for older installations installed before 2016.

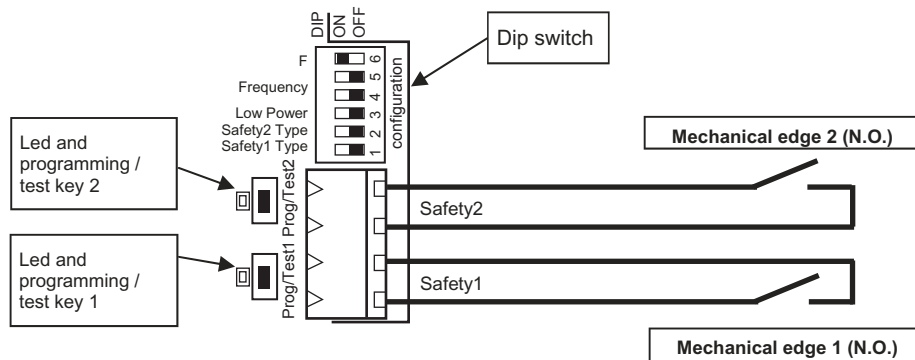

DIP1 OFF: mechanical safety edge 1
If you want to connect a mechanical edge on the input Safety1 (normally open contact), you must set dip switch 1 to «OFF».

DIP2 OFF: mechanical safety edge 2
If you want to connect a mechanical edge on the input Safety2 (normally open contact), you must set dip switch 2 to «OFF».

DIP6 ON: mechanical safety edge
If you want to use a mechanical safety edge with a normally open contact, you must set dip switch 6 to «ON».

EXAMPLE 4 - Safety edge with 8.2kΩ or 10kΩ resistive edge on input 1 and mechanical safety edge with a Normally Closed output on input 2.

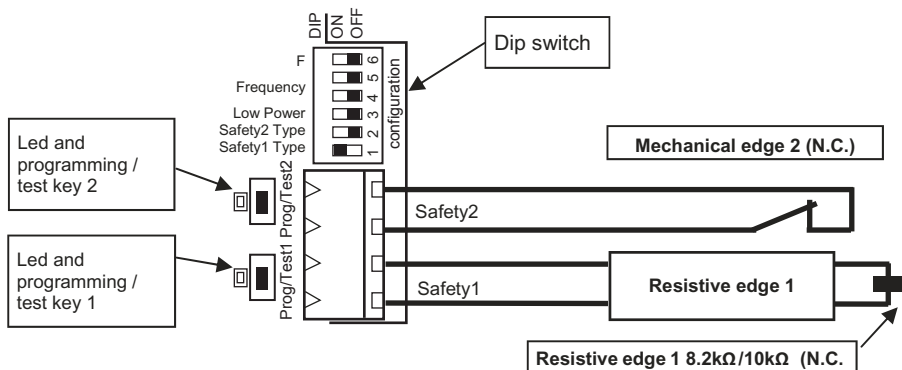

DIP1 ON: resistive safety edge 8.2kΩ/10kΩ 1
If you want to connect a resistive edge on the input Safety1 (8.2kΩ/10kΩ resistor), you must set dip switch 1 to «ON».

DIP2 OFF: mechanical safety edge 2
If you want to connect a mechanical edge on the input Safety2 (normally closed contact), you must set dip switch 2 to «OFF».

DIP6 OFF: mechanical safety edge N.C.
If you want to use a mechanical safety edge with a normally closed contact, you must set dip switch 6 to «OFF».

EXAMPLE 5 - TCO0900 with mechanical safety edge N.C. on input 1 and 8.2kΩ or 10kΩ resistive edge on input 2

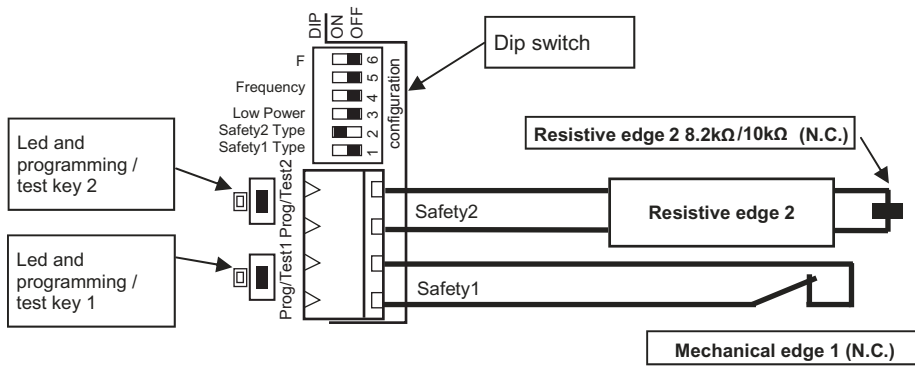

WARNING:

DIP1 OFF: mechanical safety edge 1
If you want to connect a mechanical edge on the input Safety1 (normally closed contact), you must set dip switch 1 to «OFF».

DIP2 ON: resistive safety edge 8,2kΩ/10kΩ 2
If you want to connect a resistive edge on the input Safety2 (8.2kΩ/10kΩ resistor), you must set dip switch 2 to «ON».

DIP6 OFF: mechanical safety edge
If you want to use a mechanical safety edge with a normally closed contact, you must set dip switch 6 to «OFF».

EXAMPLE 6 - 8.2kΩ or 10kΩ resistive edge on input 1 and normally open on input 2

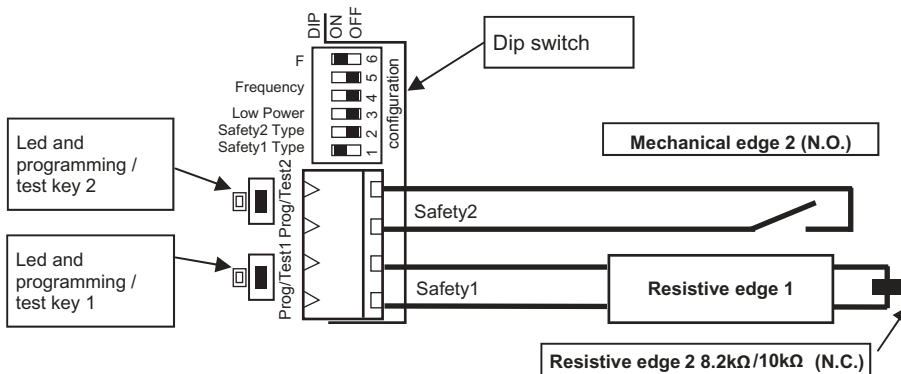

DIP1 ON: resistive safety edge 8,2kΩ/10kΩ 1

If you want to connect a resistive edge on the input Safety1 (8.2kΩ/10kΩ resistor), you must set dip switch 1 to «ON».

DIP2 OFF: mechanical safety edge 2
If you want to connect a mechanical edge on the input Safety2 (normally open contact), you must set dip switch 2 to «OFF».

DIP6 ON: mechanical safety edge
If you want to use a mechanical safety edge with a normally closed contact, you must set dip switch 6 to «ON».

EXAMPLE 7 - Normally open edge on input 1 and 8.2kΩ or 10kΩ resistive edge on input 2

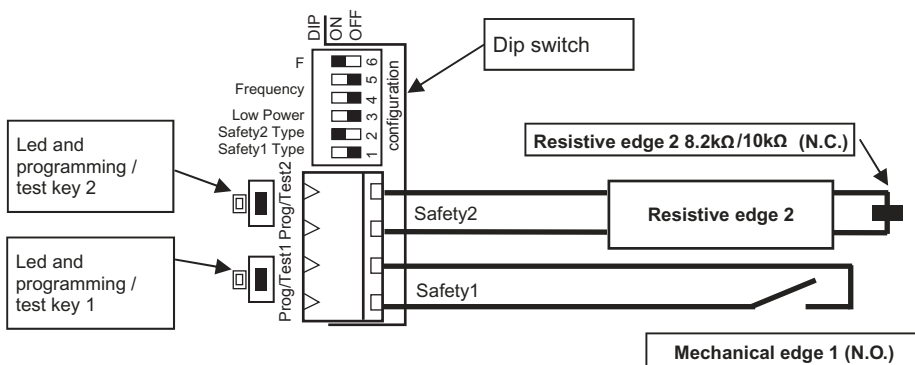

DIP1 OFF: mechanical safety edge 1

If you want to connect a mechanical edge on the input Safety1 (normally open contact), you must set dip switch 1 to «OFF».

DIP2 ON: resistive safety edge 8,2kΩ /10kΩ 2
If you want to connect a resistive edge on the input Safety2 (8.2kΩ/10kΩ resistor), you must set dip switch 2 to «ON».

DIP6 ON: mechanical safety edge
If you want to use a mechanical safety edge with a normally open contact, you must set dip switch 6 to «ON».

STEP 3

SET DIP SWITCHES 4 AND 5 ON THE TCOO900 AND 3 AND 4 ON THE RCOO900 TO THE SAME SETTINGS.

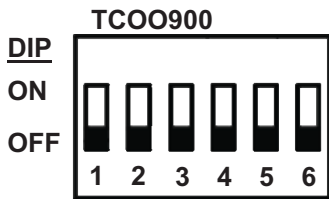

N° DIP	Function
1	Mechanical (OFF) or resistive (ON) edge 1.
2	Mechanical (OFF) or resistive (ON) edge 2.
3	Low Power. (see Section E on page 11)
4	Frequency channel selection
5	
6	Mechanical edge with N.C. contact (OFF) or Mechanical edge with N.O. contact (ON)

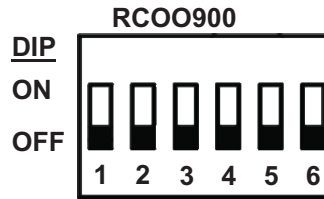

N° DIP	Function
1	Test device.
2	Buzzer ON / OFF.
3	Frequency channel selection
4	
5	NO1 output: N.O. contact (OFF) or 8k2 signal (ON) 1.
6	NO1 output: N.O. contact (OFF) or 8k2 signal (ON) 2.

It is possible to associate a maximum of 8 TCOO900 to each RCOO900.

WARNING: for a correct functioning of the system, every TCOO900 must have the frequency dip switch set the same way as the corresponding RCOO900.

Frequency channel selection

Channel	Dip 3(4)	Dip 4(5)	Frequency (MHz)
1	OFF	OFF	912.900
2	OFF	ON	914.900
3	ON	OFF	916.900
4	ON	ON	918.900

On a safety system with more than one Receiver, to avoid interference, we recommend the use of different frequency settings on each set of a RCOO900 and the associated TCOO900.

STEP 4

POWER THE TCOO900 BY INSTALLING THE TWO AA BATTERIES (1.5V) INTO THE BATTERY HOLDER. PLEASE NOTE THE CORRECT POLARITY.

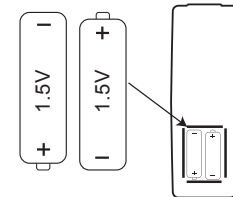

STEP 5

MOUNT THE TCOO900 AS HIGH AS POSSIBLE AND IN SUCH WAY AS THERE ARE NO OBSTACLES IN THE DIRECTION OF THE RCOO900 AND IN SUCH A WAY AS THE MAXIMUM DISTANCE BETWEEN THE TWO DEVICES IS LESS THAN 60 FEET (MAX 20 METERS / 60 FEET).

WARNING: install the TCOO900 at a minimum height of 8" from the ground. Keep the installation area clean of debris which can effect the normal operation of the system.

NOTE: Transmitter Solutions is not responsible for any damage caused by an improper, incorrect, or unintended use of the product.

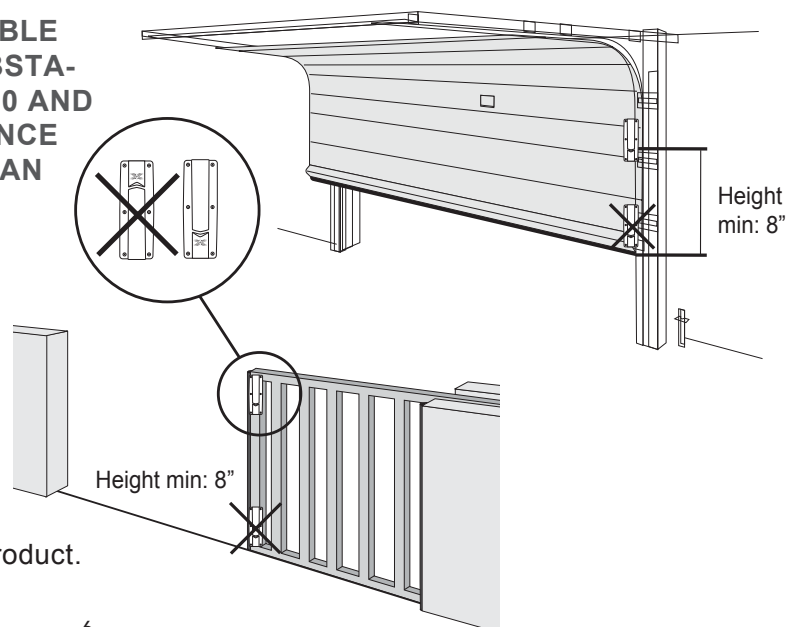

STEP 6

MOUNT THE RCOO900 AS CLOSE AS POSSIBLE TO THE TCOO900. IF MOUNTED TO A WALL, USE SUITABLE SCREWS AND ANCHORS TO SECURE THE RCOO900.

STEP 7

DEPENDING ON THE TYPE OF SIGNAL REQUIRED, CONNECT THE OUTPUTS AS EXPLAIN IN THE FOLLOWING TABLE, AND ACCORDING TO THE FOLLOWING EXAMPLES.

Table 2

OUTPUT SIGNAL	TERMINAL BOARD	SETTING OF DIP SWITCH
N.C. contact	NC1-C1 (NC2-C2)	-
N.O. contact	NO1-C1 (NO2-C2)	DIP5 OFF (DIP6 OFF)
10k Ω resistive	NO1-C1 (NO2-C2)	DIP5 ON (DIP6 ON)

WARNING: The power supply for the receiver must be an insulated transformer to protect against short circuits.

NOTE: The signals given on the outputs to relay 1 and 2 are a N.C. contact and a N.O. contact or a N.C. contact and a resistive output (10k Ω), depending on the setting of dip switches 5 and 6, and the wiring connection.

NOTE: The level of acoustic noise generated by the device is less then 70 dBA.

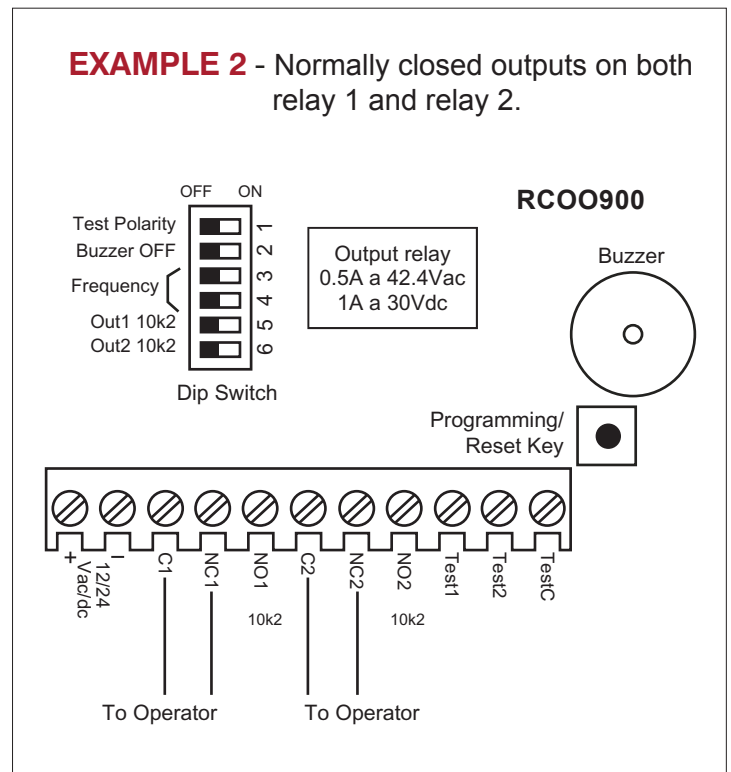
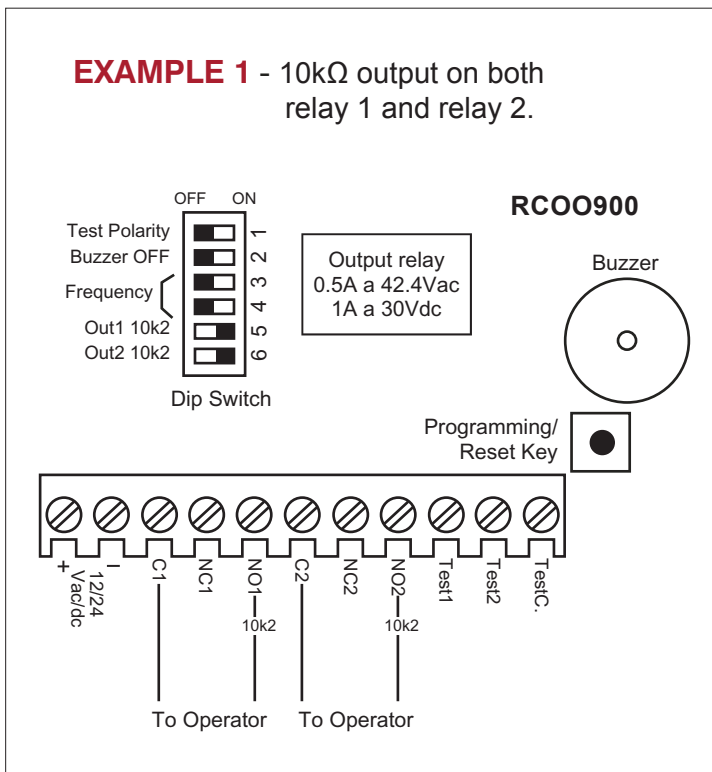

EXAMPLE 3 - Normally open outputs on both relay 1 and relay 2.

NOTE: This configuration does not meet the current UL 325-2016 requirement because it cannot be monitored.

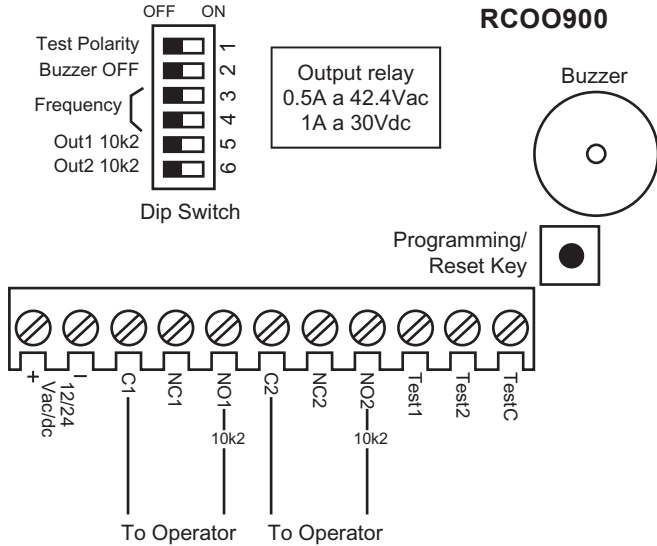

EXAMPLE 4 - Normally closed output on relay 1 and 10kΩ resistive output on relay 2.

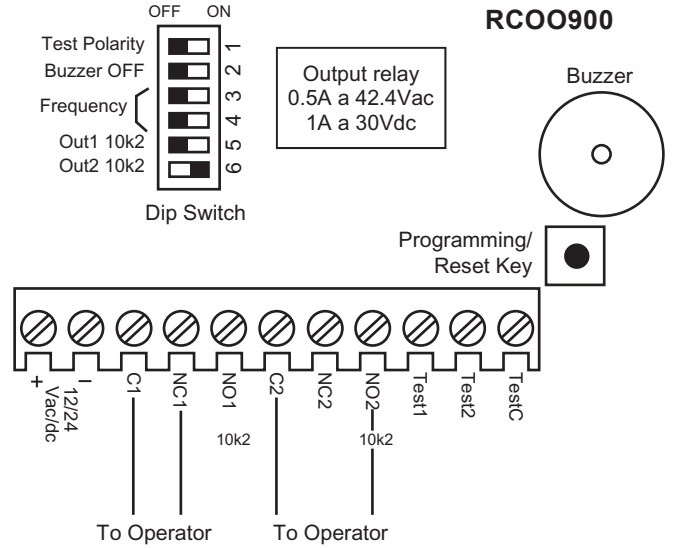

EXAMPLE 5 - 10kΩ resistive output on relay 1 and normally closed output on relay 2.

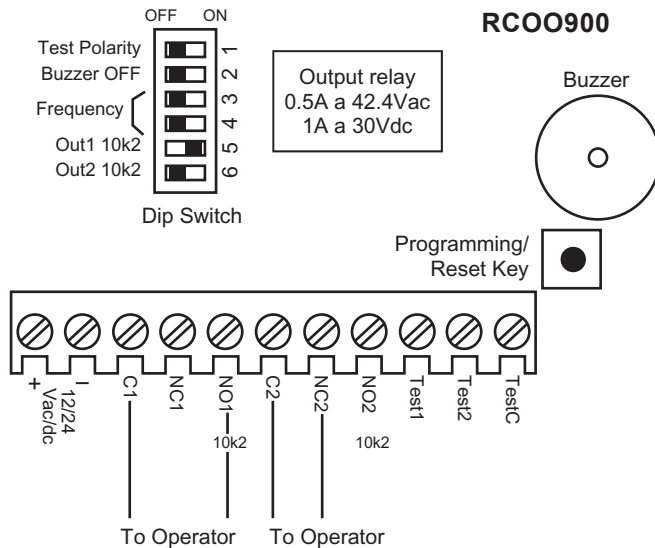

STEP 8 MOUNT THE IGAZE® RE RCOO900

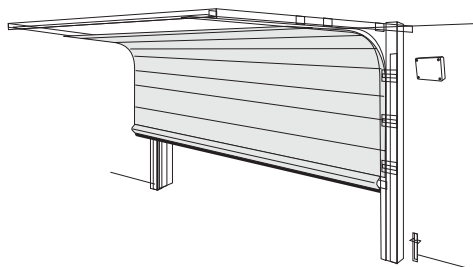

STEP 9 POWER THE RCOO900 WITH 12-24 VAC/DC INSULATED POWER SUPPLY (NOT INCLUDED WITH THE IGAZE® RE KIT).

STEP 10

PROGRAM THE TCOO900 TO THE RCOO900 ACCORDING TO THE FOLLOWING INSTRUCTIONS:

PROGRAMMING OF THE MOVABLE DEVICE ON RELAY 1 OF THE FIXED DEVICE

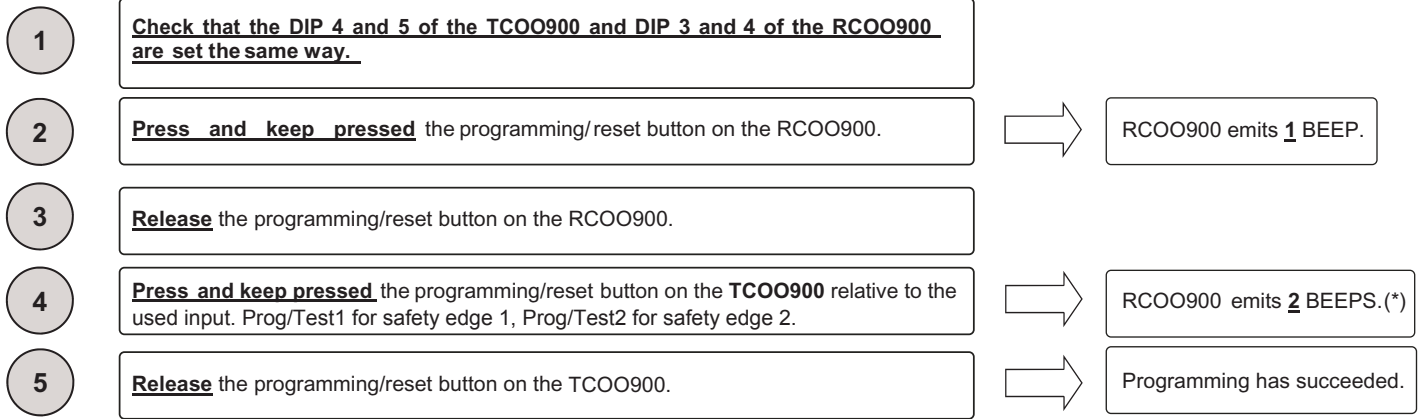

To enter more TCOO900 in the RCOO900, repeat the operation from step 2. (on page 2)

(*) **If you hear 4 BEEPS**, it means that the maximum number of safety edges for the selected channel has been reached and that no new devices on the same relay can be memorized.

NOTE: When the TCOO900 is used with two connected safety edges, it is necessary to carry out the learning process two times, one for each input.

WARNING: The same output of the TCOO900 can be memorized on both relays. To erase the memorized input it is necessary to perform a complete reset of the RCOO900 (see page 9).

PROGRAMMING OF THE TRANSMITTER ON RELAY 2 OF THE FIXED DEVICE

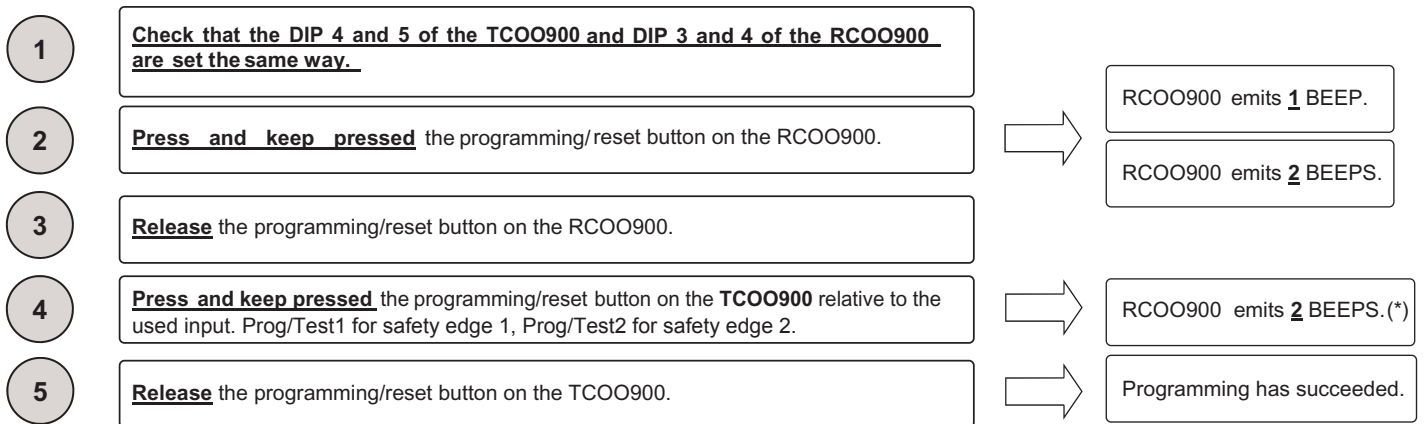

To enter more TCOO900 in the RCOO900, repeat the operation from step 2. (on page 2)

(*) **If you hear 4 BEEPS**, it means that the maximum number of safety edges for the selected channel has been reached and that no new devices on the same relay can be memorized.

NOTE: When the TCOO900 is used with two connected safety edges, it is necessary to carry out the learning process two times, one for each input.

WARNING: The same output of the TCOO900 can be memorized on both relays. To erase the memorized input it is necessary to perform a complete reset of the RCOO900 (see page 9).

STEP 11

TEST THAT THE PROGRAMMING OF THE MOVABLE DEVICE WAS SUCCESSFUL.

On each TCOO900, two buttons, labeled “programming/test key”, and two leds are present. Pushing the programming button of the edge to test during normal functioning (so not in programming) produces a signal that is sent to the RCOO900 which closes the contact of the relay and responds to this signal with:

<u>Acoustic signaling during the normal functioning</u>		
Number of BEEP/ BLINK	Meaning	What to do
1	Regular functioning, no mistake found.	-
2	One or more safety edges faulty.	Check the safety edge connections
3	One or more 8.2k /10k resistive edges disconnected.	Check the resistive edges connected
4	Battery level low.	Substitute the batteries of the indicted device
5	Low battery.	Replace the batteries
6	One or more associated devices disconnected	Check each associated device

Note: If one TCOO900 is in the alarm state and it is necessary to open or close the operating device, press and keep pressed the programming / test button of the TCOO900 in alarm at the same time the operating device is activated to open or close.

STEP 12

VERIFY THE CORRECT FUNCTION OF EACH SAFETY EDGE, MOVABLE AND FIXED DEVICES WITH THE OPERATOR INSTALLED.

D RECEIVER RESET

Using the program/reset key, it is possible to erase all TCOO900 that are programmed into the RCOO900.

NOTE: This procedure resets all memory to factory defaults.

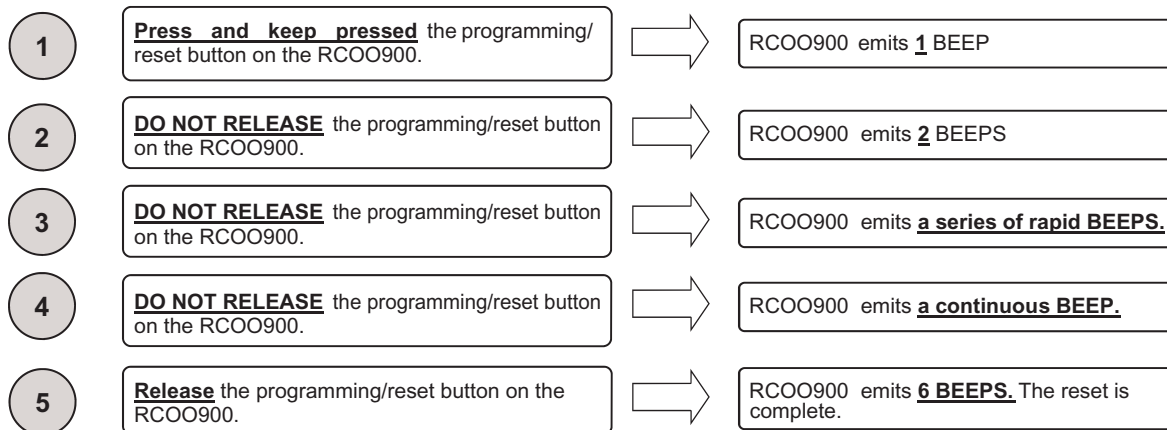

E ENERGY SAVING (LOW POWER)

With the dip switch set to low power it is important to remember that the TCOO900 will only check in with the RCOO900 every 15 seconds. If a power failure (dead battery) were to occur during this 15 second interval, the RCOO900 will only signal an alarm after the 15 second interval has been reached.

TCOO900 Dip switch 3 set **ON**: (Low power activated) state of the transmitter is checked every 15 seconds.

TCOO900 Dip switch 3 set **OFF**: (Low power deactivated) state of the transmitter is checked each second.

F DEVICES TEST

Through dip switch 1 on the receiver it is possible to select the device test to be carried out with either a high or low logic signal.

With Dip switch 1 ON: Test of the device is carried out with a low logic signal of 0Vdc between terminals TEST1 and TESTC.

With Dip switch 1 OFF: Test of the device is carried out with a high logic signal of 10Vdc to 24Vdc.

NOTE: TEST1 and TESTC are used to carry out a test for relay 1 - TEST2 and TESTC will carry out a test for relay 2 in the same manner. If you do not want to use the device test feature place Dip1 to the OFF position.

G FCC COMPLIANCE

FCC ID: SU7TCO900 and SU7RCO900

This device complies with part 15 of the FCC rules. Operation is subject to the following two conditions: (1) This device may not cause harmful interference, and (2) this device must accept any interference received, including interference that may cause undesired operation.

IMPORTANT! Any changes or modifications not expressly approved by the party responsible for compliance could void the user's authority to operate this equipment.

NOTE: This equipment has been tested and found to comply with the limits for a Class B digital device, pursuant to part 15 of the FCC Rules. These limits are designed to provide reasonable protection against harmful interference in a residential installation. This equipment generates, uses and can radiate radio frequency energy and, if not installed and used in accordance with the instructions, may cause harmful interference to radio communications. However, there is no guarantee that interference will not occur in a particular installation. If this equipment does cause harmful interference to radio or television reception, which can be determined by turning the equipment off and on, the user is encouraged to try to correct the interference by one or more of the following measures:

- Reorient or relocate the receiving antenna.
- Increase the separation between the equipment and receiver.
- Connect the equipment into an outlet on a circuit different from that to which the receiver is connected.
- Consult the dealer or an experienced radio/ TV technician for help.

FCC Radiation Exposure Statement

This equipment complies with FCC radiation exposure limits set forth for an uncontrolled environment. This equipment should be installed and operated with minimum distance 20cm between the radiator and your body.

1 – Ensure that wire leads from safety edge are securely attached to the movable device (TCOO900).

NOTE: Wire leads from safety edge have no specific polarity and can be placed in either terminal of Safety device Input1 or Safety device Input2 on the movable device.

Ensure that wire leads into the fixed device (RCOO900) are firmly connected and into proper terminals (ie N.C. or N.O.) for help in wiring RCOO900 inputs see STEP 7 examples 1 -5.

2 – Determine the type of safety edge attached to the TCOO900 – either resistive or mechanical.

How to determine the type of edge if there is no clear label:

A voltmeter can be used to determine the type of edge:

- 1- Set voltmeter to read Ohms
- 2- Place a test probe on each of the wire leads from the safety edge
- 3- If the voltmeter registers resistance (ie 8.2K Ω or 10K Ω) the safety edge is resistive
- 4- If the voltmeter does not register resistance (ie 1) the safety edge is mechanical

If safety edge is resistive ensure that DIP 1 or 2 is in the ON position (DIP 1 for Safety1 input – DIP 2 for Safety2 input) – refer to step 2

If safety edge is mechanical ensure that DIP 1 or 2 is in the OFF position (DIP 1 for Safety1 input – DIP 2 for Safety2 input) – refer to step 2

And if N.O. mechanical edge DIP 6 on the TCOO900 is in the ON position – refer to step 2

And if N.C. mechanical edge DIP 6 on the TCOO900 is in the OFF position – refer to step 2

Determine what type of output signal the gate operator is looking for:

- Doorking – 10K resistive device
- HySecurity – NC device
- NICE – 8.2K resistive device
- If 8.2k or 10k (resistive): DIP switch 5 or 6 on the RCOO900 need to be in the ON position (DIP 5 for Output1 and Safety Device 1 and DIP 6 for Output2 and Safety Device 2)
- If N.O. contact: DIP switch 5 or 6 on the RCOO900 need to be in the off position (DIP 5 for Output1 and Safety Device 1 and DIP 6 for Output2 and Safety Device 2)
- If N.C. contact: setting of DIP switch 5 and 6 on RCOO900 is not necessary

3 – To ensure that the TCOO900 and RCOO900 are communicating within the same frequency DIP switch 4 and 5 on the TCOO900 and DIP switch 3 and 4 on the RCOO900 need to be in the same position.

4 – Check batteries in TCOO900 to ensure correct polarity and sufficient power.

5 – If TCOO900 and RCOO900 are still not communicating ensure that obstacles between the devices are moved and mount devices as high as possible and away from metal objects.

WARRANTY

The warranty period of this product is 24 months, beginning from the manufacturing date. During this period, if the product does not operate correctly, due to a defective component, the product will be repaired or replaced at the sole discretion of Transmitter Solutions. This warranty does not extend to the product casing which can be damaged by conditions outside of the control of Transmitter Solutions.

EXCEPT AS SET FORTH ABOVE, TRANSMITTER SOLUTIONS MAKES NO WARRANTIES REGARDING THE GOODS, EXPRESS OR IMPLIED, INCLUDING WARRANTY OF MERCHANTABILITY OR WARRANTY OF FITNESS FOR A PARTICULAR PURPOSE. BUYER MAKES NO RELIANCE ON ANY REPRESENTATION OF TRANSMITTER SOLUTIONS, EXPRESS OR IMPLIED, WITH REGARD TO THE GOODS AND ACCEPTS THEM "AS-IS/WHERE-IS". TRANSMITTER SOLUTIONS SELLS THE GOODS TO BUYER ON CONDITION THAT TRANSMITTER SOLUTIONS WILL HAVE NO LIABILITY OF ANY KIND AS A RESULT OF THE SALE. BUYER AGREES THAT TRANSMITTER SOLUTIONS SHALL HAVE NO LIABILITY FOR DAMAGES OF ANY KIND, WHETHER DIRECT, INCIDENTAL OR CONSEQUENTIAL DAMAGES, INCLUDING INJURIES TO PERSONS OR PROPERTY, TO BUYER, ITS EMPLOYEES OR AGENTS, AS A RESULT OF THE SALE. BUYER ALSO AGREES TO HOLD TRANSMITTER SOLUTIONS HARMLESS FROM ANY CLAIMS BUYER, OR ANY THIRD PARTY, MAY HAVE AS A RESULT OF BUYER'S USE OR DISPOSAL OF THE GOODS. BUYER HAS READ THIS DISCLAIMER AND AGREES WITH ITS TERMS IN CONSIDERATION OF RECEIVING THE GOODS.



2480 South 3850 West, Suite B
Salt Lake City, UT 84120
(866) 975-0101 • (866) 975-0404 fax
www.transmittersolutions.com