



INSTALLATION INSTRUCTIONS AND SAFETY INFORMATION

FOR THE VIKING G-5S GATE OPERATOR



CLASS I
Residential Vehicular
Swing Gate Operator





The G-5S™ Viking Solar Gate Operator has the capacity to operate swing gates up to 1000 lbs. and 16 ft. long under extreme conditions. This efficient operator provides a solution for residential swing gate solar applications thanks to its efficient electromechanical design. Equipped with the latest solar innovations, the G-5S™ is the most energy efficient swing gate operator offered on the market.

THE VIKING G-5S™ SOLAR SWING GATE OPERATOR

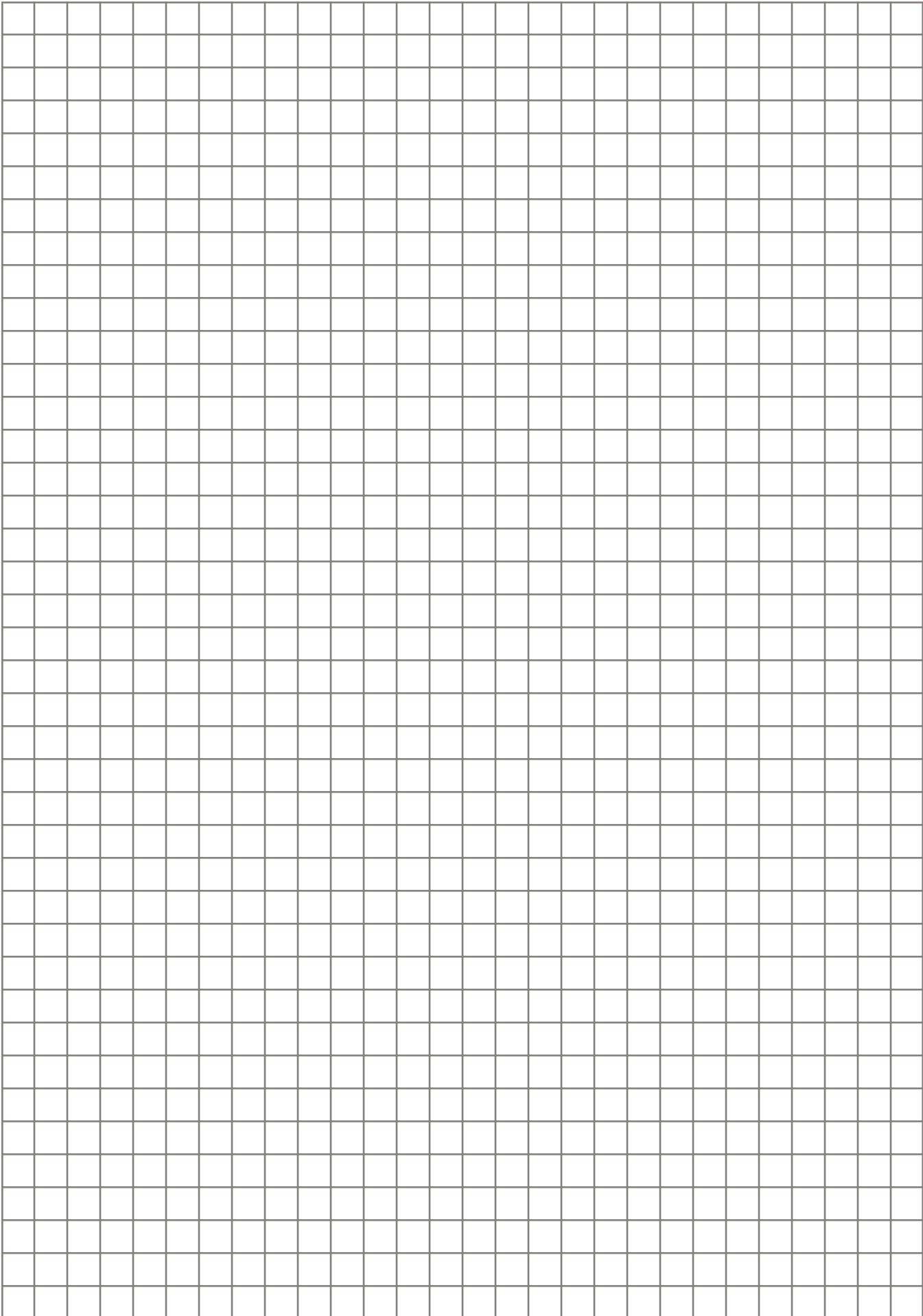

PARTS DIAGRAM - OPERATOR:

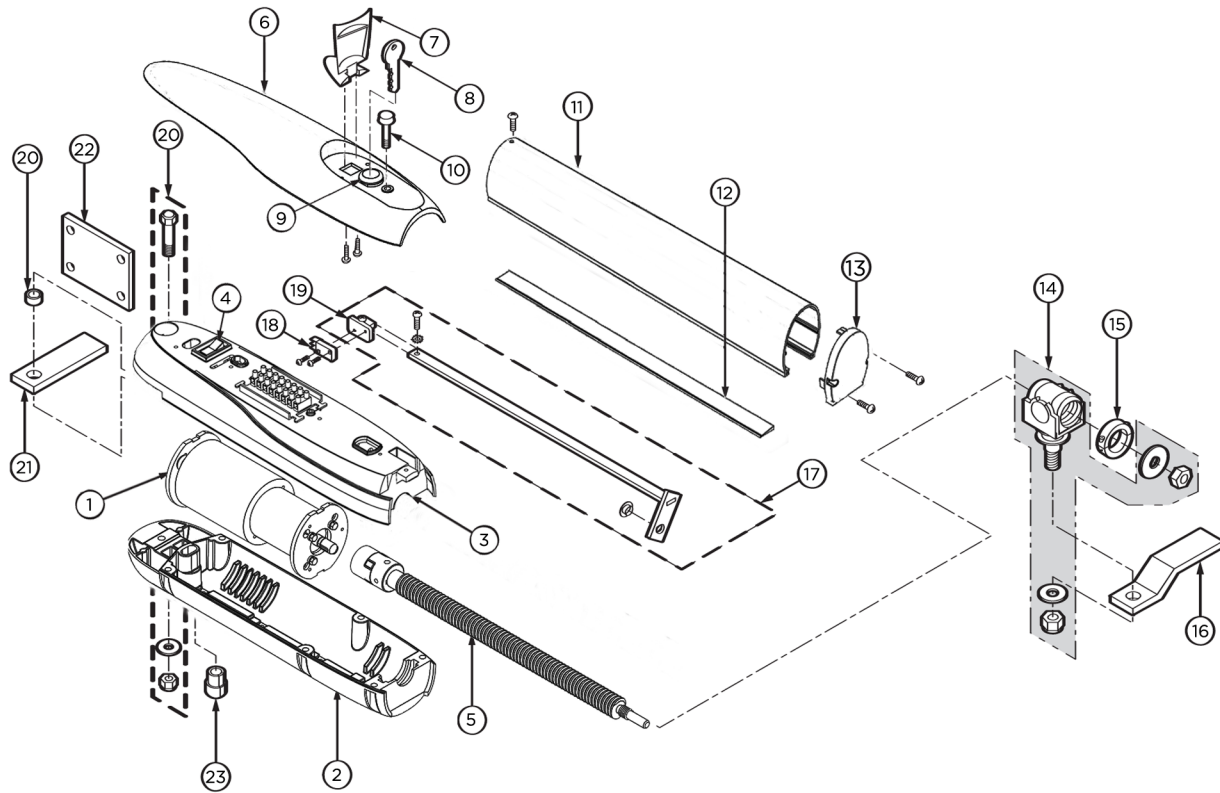

Item	Description	Part No.
1	24V DC Motor	VG5MOSLR
2	G5 Motor Casing Lower	VNXG5CL
3	G5 Motor Casing Upper	VNXG5CU
4	Manual Release Switch	DUMRS20
5	Lead Screw (w/ coupler)	VNXG5LDSW
6	Cover, Terminal	VNXG5CT
7	Door, Cover Release	VNXG5DCR
8	Key, Cover Release	VNXG5K
9	Key Cylinder, Cover Release	VNXG5KC
10	Thumbscrew, Cover Release	VNXG5TSCR
11	Cover, Lead Screw	VNXG5CLS
12	Dust Brush (2)	VNXG5DB
13	End Cap, Lead Screw Cover	VNXG5ECC
14	Carrier with Hardware	VNXG5C78
15	Positive Stop	VAG5PSE
16	Mounting Bracket, Front	VNXG5MBF78
17	Limit Mounting Bar	VNXG5LMB
18	Limit Switch (2)	VNXG5LS
19	Limit Switch Bracket (2)	VNXG5LSB
20	Mounting Hardware, Back	VNXG5MHB
21	Mounting Bracket, Back	VNXG5MBB
22	Backing Plate, Bracket Mount (2)	VNXG5BPBM
23	Strain Relief (G-5)	VNXG5SRCH

Overall Dimensions

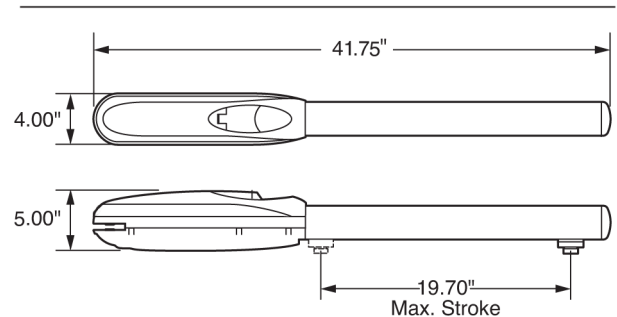

Weight

40 lb.

PARTS DIAGRAM - ECU BOX:

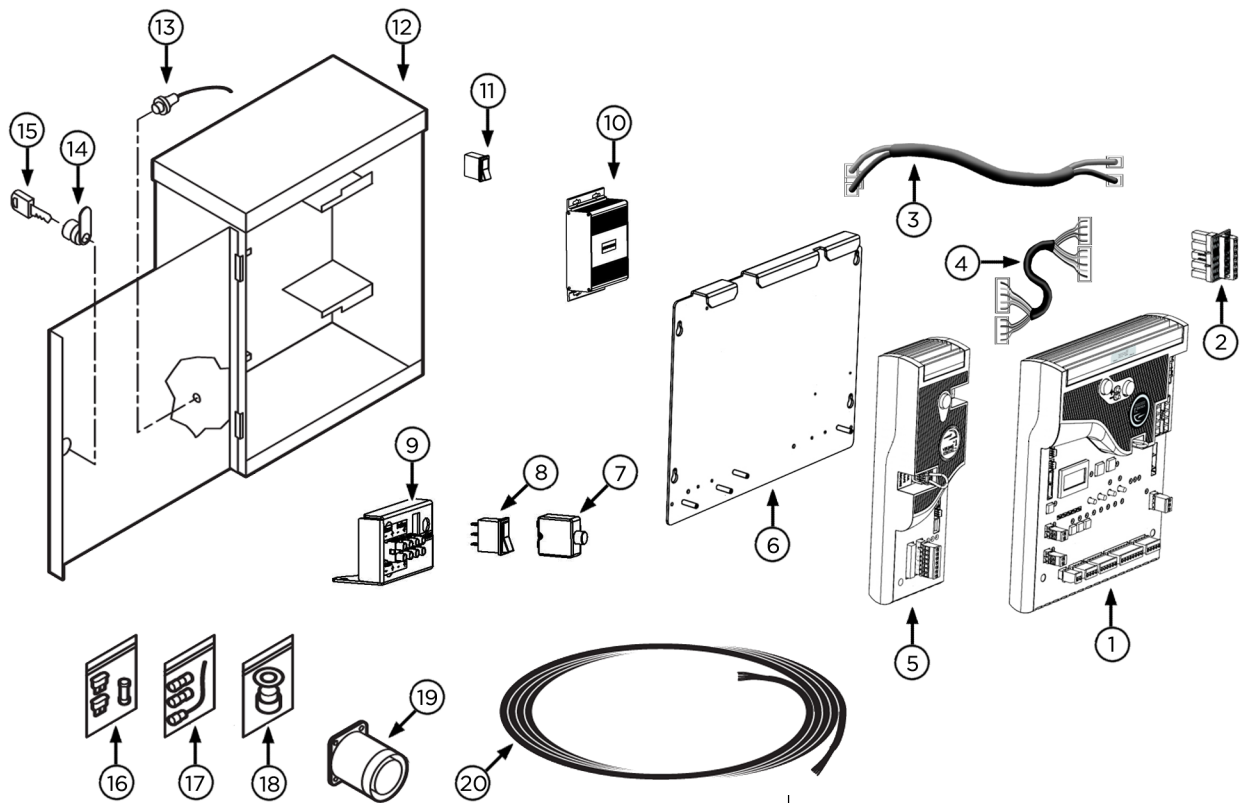

Item	Description	Part No.
1	Solar Control Board	VSPCBU16
2	Motor Connector - Master	VEUCMCM
3	Slave Power Harness <i>(Dual Controller only)</i>	VECUSPH
4	Master/Slave Comm Cable <i>(Dual Controller only)</i>	VEUCMSC
5	Slave Solar Module <i>(Dual Controller only)</i>	VSSMPCBU16
6	Board Mounting Plate	VECUBMP
7	Solar Battery Breaker	VASBB25
8	Solar Panel Switch	DUMRS5
9	Solar Terminal Block Assembly	VSTBAECU
10	Solar Charger	VSCHARGEUCU
11	Power Switch	DUMRS10
12	ECU Cabinet Chassis	VNXCUBB
13	Alarm Reset Switch	ECURW
14	ECU Key Cylinder & Key(s)	ECUKEYC20
15	ECU Access Key(s)	ECUKEY20
16	Fuse Kit	DUFSKNX
17	Radio Antenna Kit	VARAK
18	Strain Relief (ECU)	DH3/4NMCC
19	Alarm	DUAL10
20	6 Conductor Cable, 16 AWG Shielded	VA-CB16

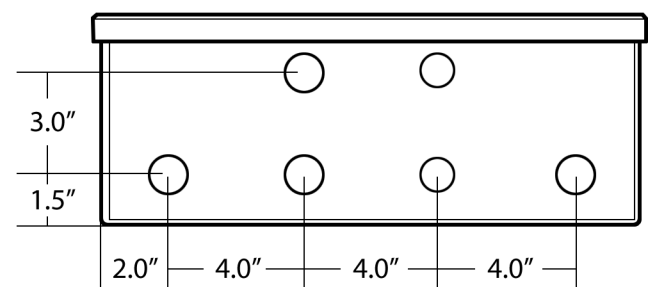
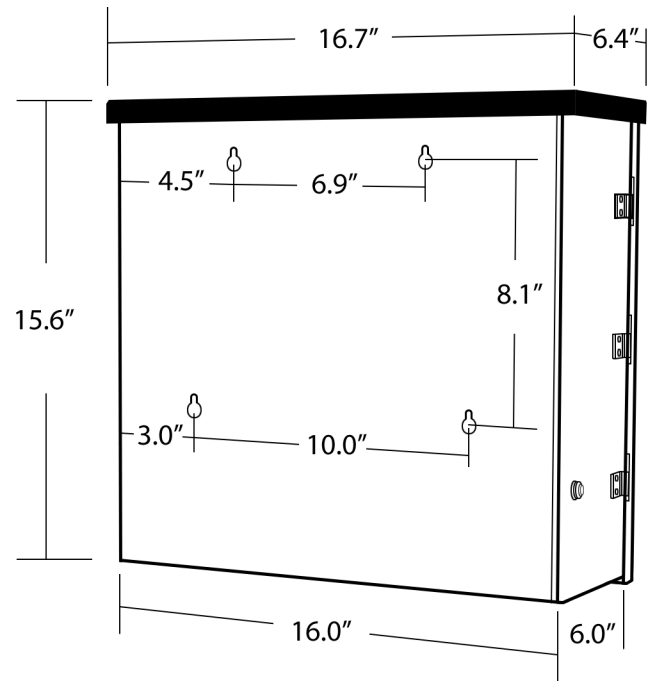

CONTROL BOARD REFERENCES:

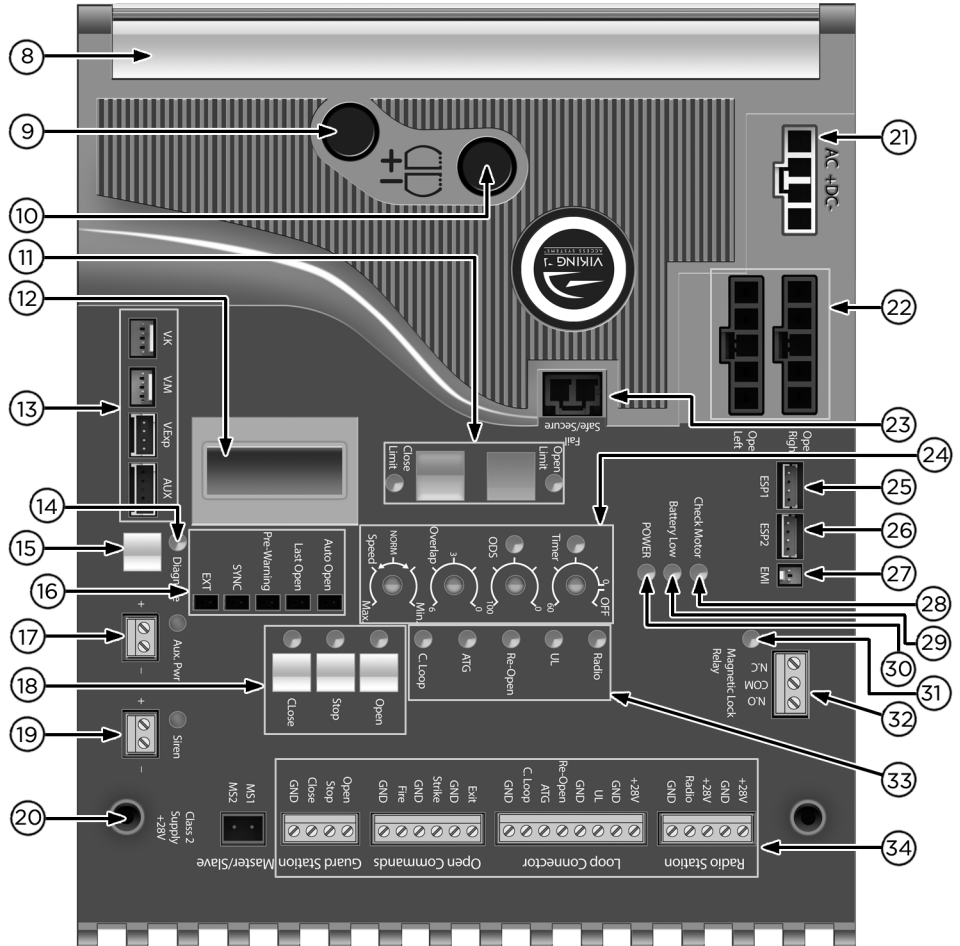
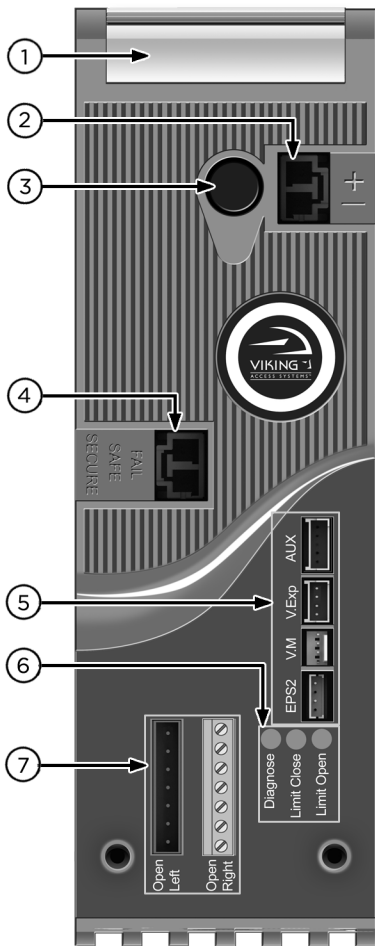

1. HEAT SINK - SLAVE MODULE
secures the control board and dissipates heat.
2. SLAVE MODULE POWER HARNESS CONNECTOR
provides power to the Slave Module. pg 23
3. FUSE HOLDER - 15 AMP
for the Slave motor circuit.
4. "FAIL SAFE/SECURE" Jumper - SLAVE MODULE
power failure option. pg 26
5. M/S COMM CABLE CONNECTION - SLAVE MODULE
for master/slave (dual) gate application. pg 23
6. STATUS LEDs - SLAVE MODULE
provides diagnostic information.
7. SLAVE MOTOR CONNECTION
provides power to the Slave motor. pg 23
8. HEAT SINK - MASTER/SINGLE
secures the control board and dissipates heat.
9. FUSE HOLDER - 4 AMP
not applicable to this model.
10. FUSE HOLDER - 15 AMP
for the Master motor circuit.
11. LIMIT SETUP BUTTONS
available for future developments.
12. LCD DIAGNOSTICS DISPLAY
provides error messages, diagnostics settings
and operator status information. pg 36-38

13. M/S COMM CABLE CONNECTION - MASTER BOARD
for master/slave (dual) gate application. pg 23
14. "DIAGNOSE" LED
informs that errors have been detected and
available on LCD Display. pg 36-38
15. "DIAGNOSE" Button
allows you to navigate through the
Diagnostics LCD Display. pg 36-38
16. FEATURE ACTIVATION PIN HEADERS
activate features by placing a jumper onto the
pin headers. pg 26
17. "AUX. PWR" Terminal Block
used for solar applications & in-motion
warning devices. pg 21, 26
18. ON-BOARD 3 BUTTON STATION
controls the gate during set up.
19. "Siren" TERMINAL BLOCK
Vikings UL Siren is connected here. pg 12, 27
20. CONTROL BOARD MOUNTING HOLES
secures and grounds the control board.
21. POWER HARNESS CONNECTOR
provides power to the control board. pg 21
22. MASTER or SINGLE MOTOR CONNECTION
provides power to the motor. pg 22
23. "FAIL SAFE/SECURE" Jumper
power failure option. pg 26

24. FEATURE ACTIVATION TRIM POTS
activate and set features. pg 25
25. "EPS1" CONNECTOR
communication for Viking Solar Charger.
26. "EPS2" CONNECTOR
available for future developments.
27. "EMI" CONNECTOR
not applicable to this model.
28. "CHECK MOTOR" Status LED
indicates motor power status. pg 34
29. "BATTERY LOW" Status LED
indicates battery power status. pg 34
30. "POWER" Status LED
control board power status. pg 34
31. "MAGNETIC LOCK Relay" Status LED
status of this on-board relay. pg 34
32. "MAGNETIC LOCK Relay" Terminal Block
connect electric locks here. pg 34
33. INPUT STATUS LEDs
indicates input status. pg 34-35
34. ACCESS CONTROL TERMINAL BLOCKS
accessory connections. pg 28-31, 40-42

TABLE OF CONTENTS:

PARTS DIAGRAM/PARTS LIST	2-3
CONTROL BOARD REFERENCES	4
IMPORTANT SAFETY INFORMATION	6-12
Important Safety Instructions.....	6
Important Installation Instructions.....	7
Maintenance.....	8
General Safety Precautions.....	8-9
Operator Classification.....	9
Secondary Entrapment Protection Requirements.....	10
Secondary Entrapment Protection Installation.....	11
Manual Release.....	11
Audible Alarm Reset Installation.....	12
Warning Placard Installation.....	12
IMPORTANT INSTALLATION INFORMATION	13
Specifications.....	13
GATE OPERATOR INSTALLATION	14-17
Pull to Open Installation.....	14
Push to Open Installation.....	15
Mounting the Gate Operator.....	16
Limit Switch Setup.....	17
ECU BOX INSTALLATION	18
ELECTRICAL INSTALLATION	19-23
Battery & Solar Panel Selection.....	19
Solar Panel Care & Installation Tips.....	20
Solar Connection & Power Saving Tips.....	21
Motor Cable.....	22-23
LIMIT INDICATIONS	24
CONTROL BOARD SETUP	25-27
Initial Settings.....	25-26
Obstruction Detection Sensor (Primary Entrapment Protection).....	27
ACCESSORY CONNECTIONS	28-33
Re-Open Photo Beam (Vehicular Safety).....	28
Radio Receiver (Typical).....	29
Anti-Tailgate, Open Commands, Guard Station.....	30
Viking Loop Rack.....	31
Guidelines for Loop Installations.....	32
Barrier Arm (B-12) Synchronization Option.....	33
TROUBLESHOOTING	34-39
LED References.....	34-35
LCD Display References.....	36-38
Solutions.....	39
APPENDIX A, B & C	40-43
VIKING EXPANSION PRODUCTS	44

IMPORTANT SAFETY INFORMATION

⚠ WARNING! Not Following these instructions may cause severe injury or death.

IMPORTANT SAFETY INSTRUCTIONS

⚠ WARNING! To reduce the risk of severe injury or death.

1. READ AND FOLLOW ALL INSTRUCTIONS.
2. Never let children operate or play with gate controls. Keep the remote away from children.
3. Always keep people and objects away from the gate. **NO ONE SHOULD CROSS THE PATH OF THE MOVING GATE.**
4. Test the gate operator monthly. The gate **MUST** reverse on contact with a rigid object or when an object activates the non-contact sensors. After adjusting the force or the limit travel, retest the gate operator. Failure to adjust and retest the gate operator properly can increase the risk of injury or death.
5. Use the emergency release only when the gate is not moving.
6. **KEEP GATES PROPERLY MAINTAINED.** Read the user's manual. Have a qualified service person make repairs to gate hardware.
7. The entrance is for vehicles only. Pedestrians must use a separate entrance.
8. **Every gate operator installation MUST have secondary protection devices against entrapment, such as edge sensors and photo beams more in particular in places where the risk of entrapment is more likely to occur.**
9. SAVE THESE INSTRUCTIONS.

IMPORTANT INSTALLATION INSTRUCTIONS

1. Install the gate operator only when:
 - a. The operator is appropriate for the construction of the gate and usage Class of the gate (refer to page 9),
 - b. All openings of a horizontal slide gate are guarded or screened from the bottom of the gate to a minimum of 6 feet (1.83 m) above the ground to prevent a 2-1/4 inch (57.2 mm) diameter sphere from passing through the openings anywhere in the gate, and in that portion of the adjacent fence that the gate covers in the open position,
 - c. ALL EXPOSED PINCH POINTS ARE ELIMINATED OR GUARDED, AND
 - d. GUARDING IS SUPPLIED FOR EXPOSED ROLLERS.
2. The Operator is intended for installation only on gates used for vehicles. Pedestrians must be supplied with a separate access opening. The pedestrian access opening shall be designed to promote pedestrian usage. Locate the gate such that persons will not come into contact with the vehicular gate during the entire path of travel of the vehicular gate.
3. The gate must be installed in a location so that enough clearance is supplied between the gate and adjacent structures when opening and closing to reduce the risk of entrapment. Swinging gates shall not open in to the public access areas.
4. The gate must be properly installed and work freely in both directions prior to the installation of the gate operator. Do not over-tighten the operator clutch or pressure relief valve to compensate for a damaged gate.
5. The gate operator controls must be placed so that the user has full view of the gate area when the gate is moving **AND AWAY FROM THE GATE PATH PERIMETER.**

IMPORTANT SAFETY INFORMATION

 **WARNING! Not Following these instructions may cause severe injury or death.**

IMPORTANT INSTALLATION INSTRUCTIONS (Continued)

6. Controls intended for user activation must be located at least six feet (6') away from any moving part of the gate and where the user is prevented from reaching over, under, around or through the gate to operate the controls.
Exception: Emergency access controls only accessible by authorized personnel (i.e. fire, police, EMS) may be placed at any location in the line-of-sight of the gate.
7. The Stop and/or Reset button must be located in the line-of-sight of the gate. Activation of the reset control shall not cause the operator to start.
8. A minimum of two (2) WARNING SIGNS shall be installed, in the area of the gate. Each placard is to be visible by persons located on the side of the gate on which the placard is installed.
9. **For gate operators using non-contact sensors (photoelectric beam or like) in accordance with section 31.1.1 of the UL standard:**
 - a. See instructions on the placement of non-contact sensors for each type of application (refer to page 10).
 - b. Care shall be exercised to reduce the risk of nuisance tripping, such as when a vehicle, trips the sensor while the gate is still moving, and
 - c. One or more non-contact sensors shall be located where the risk of entrapment or obstruction exists, such as the perimeter reachable by a moving gate or barrier (refer to page 10).
 - d. Use only Miller Edge photoelectric beams (refer to pages 10-11).
10. **For a gate operator utilizing a contact sensor (edge sensor or like) in accordance with section 31.1.1 of the UL 325 standard:**
 - a. One or more contact sensors shall be located where the risk of entrapment or obstruction exists, such as a the leading edge, trailing edge, and post mounted both inside and outside of a vehicular horizontal slide gate (refer to page 10).
 - b. One or more contact sensors shall be located at the bottom of a vehicular vertical lift gate.
 - c. One or more contact sensors shall be located at the pinch point of a vehicular vertical pivot gate.
 - d. A hardwired contact sensor shall be located and its wiring arranged so that the communication between the sensor and the gate operator is not subject to mechanical damage.
 - e. A wireless contact sensor such as one that transmits radio frequency (RF) signals to the gate operator for entrapment protection functions shall be located where the transmission of the signals are not obstructed or impeded by building structures, natural landscaping or similar obstructions. A wireless contact sensor shall function under the intended end-use conditions.
 - f. One or more contact sensors shall be located on the inside and outside leading edge of a swing gate. Additionally, if the bottom edge of a swing gate is greater than 6 inches (152 mm) but less than 16 inches (406 mm) above the ground at any point in its arc of travel, one or more contact sensors shall be located on the bottom edge.
 - g. One or more contact sensors shall be located at the bottom edge of a vertical barrier (arm).
 - h. Use only Miller Edge edge sensor (refer to pages 10-11).

IMPORTANT SAFETY INFORMATION

 **WARNING! Not Following these instructions may cause severe injury or death.**

MAINTENANCE

Remove the Power Harness from the Control Board. (refer to page 21)

- Clean and lubricate the turning pins and gate hinges using the recommended lubricant.
- Check that all mounting hardware of the gate operator is properly tighten.
- Ensure that the gate moves freely.
- Check for corroded parts and replace if necessary.
- Check the battery for the following:
 - Battery connections must be free of corrosion.
 - Battery voltage must be 13VDC (fully charged battery).

Reconnect the Power Harness for the Control Board. (refer to page 21)

- Check and confirm the proper operation of all safety devices (photoelectric eye, edge sensors or like).
- Check and confirm the operation of all installed accessories.
- Check and confirm the operation of all special features such as the Intelligent Obstruction Sensor and Hold Open Timer. (refer to pages 25-27)
- Check and confirm the operation of the manual release. (refer to page 11)

GENERAL SAFETY PRECAUTIONS

The following precautions are an integral and essential part of the product and must be supplied to the user. Read them carefully as they contain important indications for the safe installation, use and maintenance.

- These instruction must be kept and forwarded to all possible future users of the system.
- This product must be used only for that which it has been expressly designed.
- Any other use is to be considered improper and therefore dangerous.
- The manufacturer cannot be held responsible for possible damage caused by improper, erroneous or unreasonable use.
- Avoid operating in the proximity of the hinges or moving mechanical parts.
- Do not enter the path of the moving gate while in motion.
- Do not obstruct the motion of the gate as this may cause a situation of danger.
- Do not allow children to play or stay within the path of the moving gate.
- Keep remote control or any other control devices out of the reach of children, in order to avoid possible involuntary activation of the gate operator.
- In case of break down or malfunctioning of the product, disconnect from the main power source. Do not attempt to repair or intervene directly, contact only qualified personnel for repair.
- Failure to comply with the above may create a situation of danger.
- All cleaning, maintenance or repair work must be carried out by qualified personnel.
- In order to guarantee that the system works efficiently and correctly it is important to have the manufacturer's instructions on maintenance of the gate and operator carried out by qualified personnel.
- In particular, regular checks are recommended in order to verify that the safety devices are operating correctly.

All installation, maintenance and repair work must be documented and made available to the user.

IMPORTANT SAFETY INFORMATION

⚠ CAUTION: To Reduce the Risk of Fire or Injury to Persons:

UL325 Gate Operator Classifications

GLOSSARY

RESIDENTIAL VEHICULAR GATE OPERATOR

CLASS I - A vehicular gate operator (or system) intended for use in garages or parking areas associated with a residence of one-to four single families.

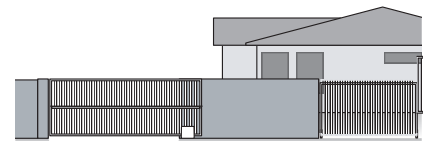

COMMERCIAL/GENERAL ACCESS VEHICULAR GATE OPERATOR

CLASS II - A vehicular gate operator (or system) intended for use in a commercial location or building such as a multi-family housing unit (five or more single family units), hotel, garages, retail store, or other building servicing the general public.

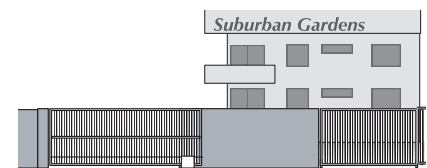

INDUSTRIAL/LIMITED ACCESS VEHICULAR GATE OPERATOR

CLASS III - A vehicular gate operator (or system) intended for use in an industrial location or building such as a factory or loading dock area or other locations not accessible by or intended to service the general public.

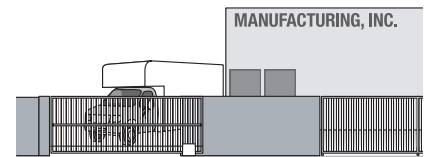

RESTRICTED ACCESS VEHICULAR GATE OPERATOR

CLASS IV - A vehicular gate operator (or system) intended for use in a guarded industrial location or building such as an airport security area or other restricted access locations not servicing the general public, in which unauthorized access is prevented via supervision by security personnel.

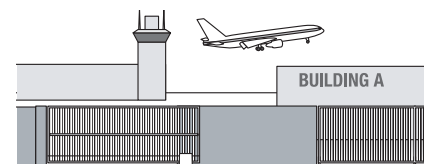

Install the gate operator only when:

The operator is appropriate for the construction of the gate and the Usage Class of the gate.

IMPORTANT SAFETY INFORMATION

⚠ WARNING! Not Following these instructions may cause severe injury or death.

Secondary Entrapment Protection Requirements

IMPORTANT: SECONDARY PROTECTION MUST BE INSTALLED

- **REQUIRED BY UL 325, an approved MONITORED secondary entrapment protection sensor is REQUIRED to be installed in all areas accessible to potential entrapment and pinch points.**
- The installed sensor **MUST** be **“10K Resistor Based”**.
- At least **ONE** monitored sensor **MUST** be connected. (also, refer to page 43)
- You may connect up to **FOUR** monitored sensors, wired parallel.
- **Failure to install an approved monitored secondary entrapment protection sensor will render the gate operator INOPERABLE until one is installed.**
- Consult the installation manual of the sensor for detailed information about the usage, installation and maintenance.
- This type of installation will only reverse the gate approximately 12” in the opposite direction it was traveling when the sensor is triggered. (also, refer to page 43)
- This type on installation is to protect against entrapment only and **DOES NOT** reverse the gate all the way back to its limits when the sensor is triggered. (also, refer to page 43)
- Use only UL Listed Edge Sensor and Photoelectric Beams.

Photo Beam (non-contact sensor)

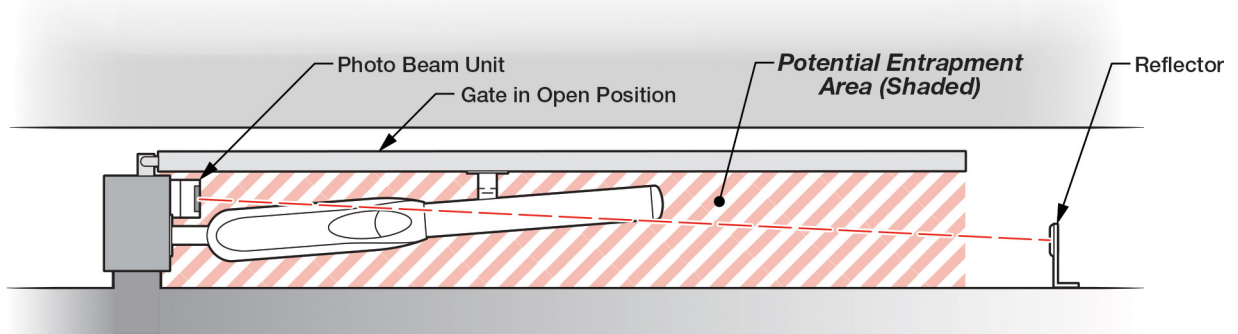

Edge Sensor (contact sensor)

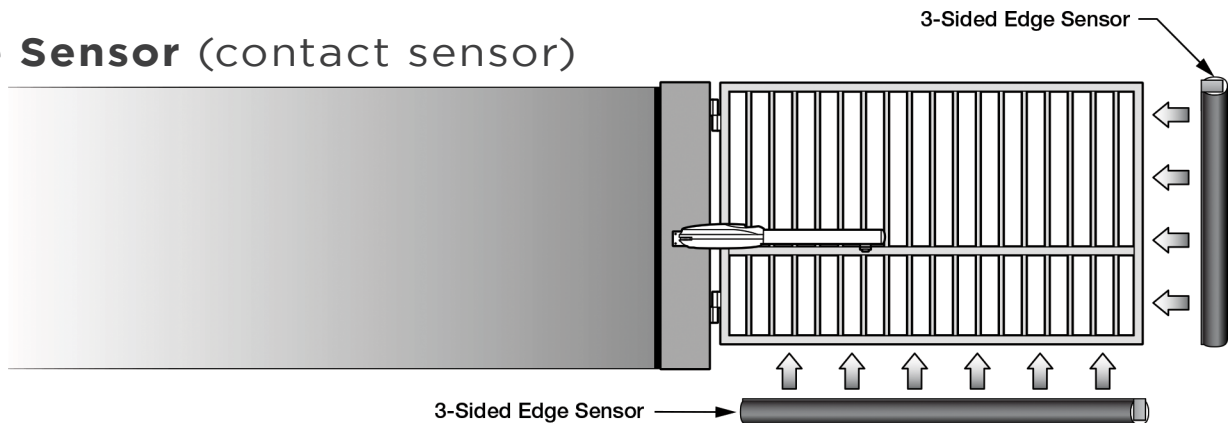

IMPORTANT SAFETY INFORMATION

⚠ WARNING! Not Following these instructions may cause severe injury or death.

Secondary Entrapment Protection Installation

STEP 1

Connect the secondary entrapment protection sensor(s) to the Viking control board as illustrated below. Up to four 10K resistor based sensors can be wired in parallel.

STEP 2

Confirm the number of sensors connected:

- Toggle the “Diagnose” button until you see **UL LEARN** on the LCD Display.
- Default setting is 1 sensor.

Proceed with the following Learn Process:

- If the number of connected sensors does not match the display.
- If the “Stop” LED is flashing.
- If the error message **ERR UL SENSOR** is displayed.

LEARN PROCESS

With the “UL LEARN” menu displayed and all secondary sensors properly connected to the control board:

- Press and hold the “Stop” button.
- Toggle the “Diagnose” button once.
- The correct number of sensors should now be displayed.

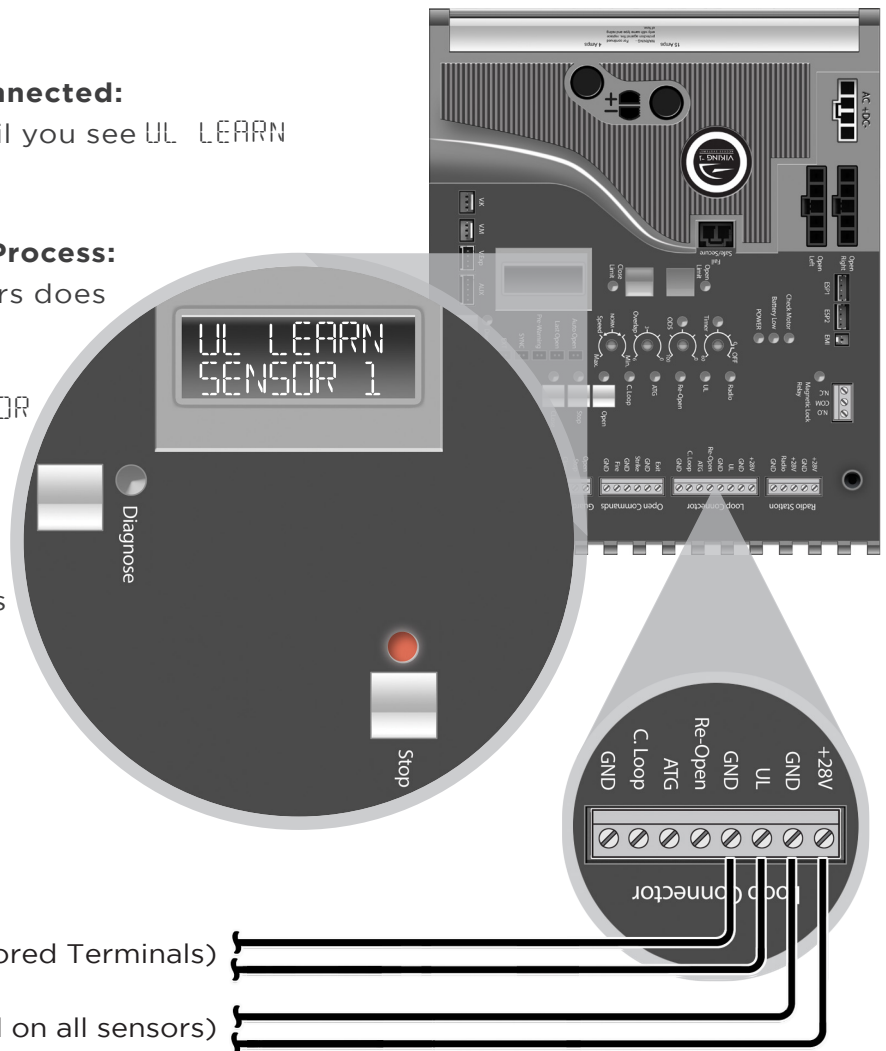

Manual Release

When manual operation is required:

1. Unlock and remove the Top Cover with the Key or optional Thumb Screw.
2. Press the Manual Release Switch to the “RELEASE” Position.

The gate can now be moved manually. To resume normal operation, press the switch to the “ENGAGE” position.

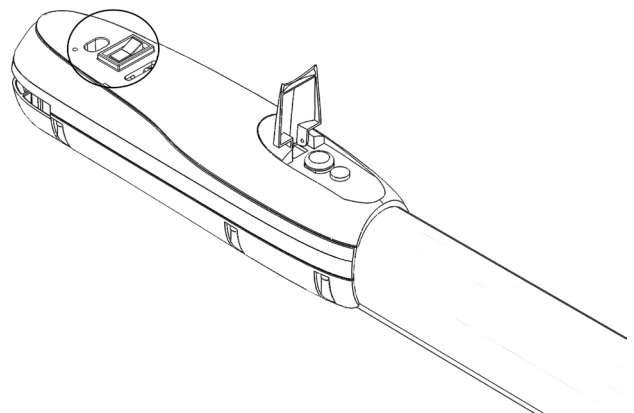

IMPORTANT SAFETY INFORMATION

⚠ WARNING! Not Following these instructions may cause severe injury or death.

Audible Alarm Reset Switch Installation

Manual Reset for the Audible Alarm

- UL325 standard requires an audible alarm to sound after two consecutive events detected by the primary entrapment protection of the gate operator (obstruction sensor).
- The audible alarm will continue to sound for 5 minutes or until a stop command gets actuated.
- The Stop command can be actuated in three different forms:
 1. Using the Built in Stop switch on the Control Board; or
 2. Using an External Stop button within the sight of the gate, away from moving parts of the gate and out of reach of children.
 - a. Controls intended for user activation must be located at least six feet (6') away from any moving part of the gate and where the user is prevented from reaching over, under, around, or through the gate to operate the controls. Outdoor or easily accessible controls shall have a security feature to prevent unauthorized use.
 - b. The Stop and/or Reset button must be located in the line-of-sight of the gate. Activation of the reset control shall not cause the operator to start.
 3. Using the Reset Button on the Electronic Control Unit that is externally accessible on the left side of the cabinet.

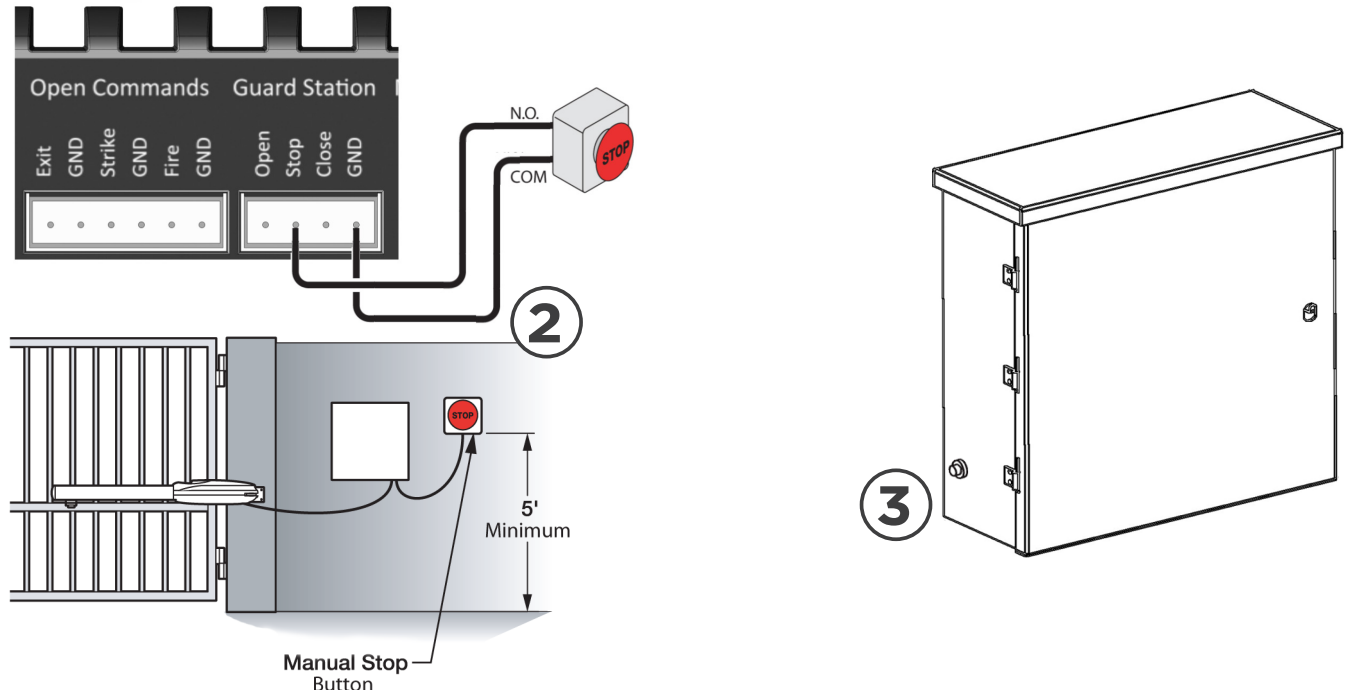

Warning Placard Installation

- All Warning Placards must be installed where visible in the area of the gate.
- A minimum of two placards shall be installed.
- A placard is to be installed in the area of each side of the gate and be visible.

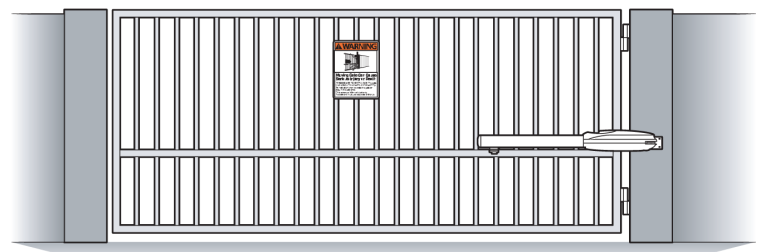

IMPORTANT INSTALLATION INFORMATION

⚠ CAUTION: To Reduce the Risk of Fire or Injury to Persons:

⚠ WARNING: For use with gates at a maximum 1000 lbs. in weight or 16 ft. in length.



DO NOT allow pedestrian use of this gate

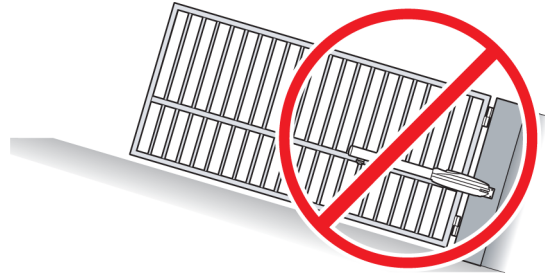

DO NOT install the gate operator to lift gates

Locate Control Buttons:

1. Within sight of the gate,
2. At a minimum height of 5 feet so small children are not able to reach it; and
3. At least 6 feet away from all moving parts of the gate.

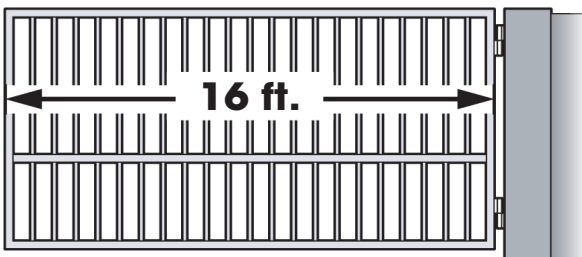
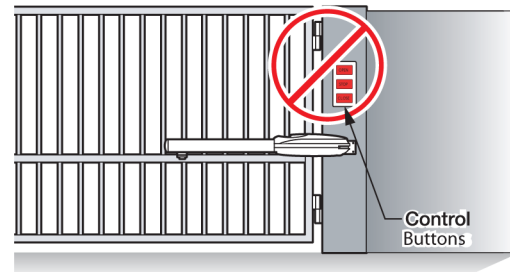

G-5S Specifications:

UL Application Class:	Class I
Maximum Gate Length:	16 ft.
Maximum Gate Weight:	1000 lb.
Operating Temperature:	-4°F (-20°C) to 160°F (71°C)

GATE OPERATOR INSTALLATION

Pull to Open Installation Option

This application is typically used to open the gate towards the inside of the property. The operator will “**PULL**” the gate to open.

1. The gate must be installed in a location so that enough clearance is provided between the gate and adjacent structures to reduce the risk of entrapment when opening and closing.
2. Swing gates are not to open into public access areas.

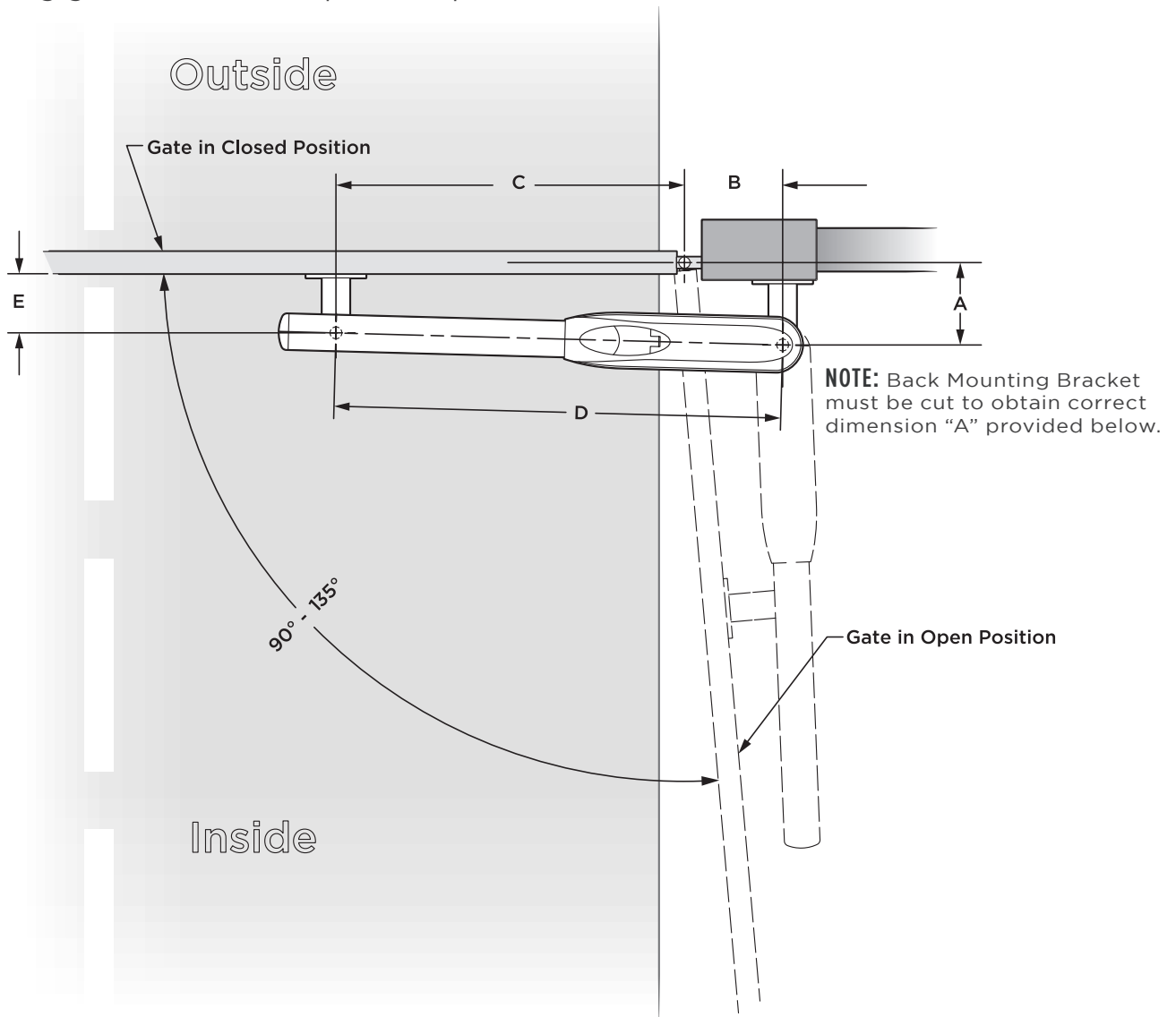

ALL DIMENSIONS ARE MEASURED IN INCHES

Range	A	B	C	D	E	Opening Time
90° - 120°	6.000	4.500	27.000	31.500	4.750	Faster
90° - 120°	6.625	7.875	28.000	35.875	4.750	Slower
121° - 135°	7.500	7.750	28.500	36.250	5.500	

⚠ Varying from the dimensions provided above may severely affect the speed and performance of the gate operator.

GATE OPERATOR INSTALLATION

Push to Open Installation Option

This application is typically used to open the gate towards the outside of the property. The operator will “**PUSH**” the gate open.

1. The gate must be installed in a location so that enough clearance is provided between the gate and adjacent structures to reduce the risk of entrapment when opening and closing.
2. Swing gates are not to open into public access areas.

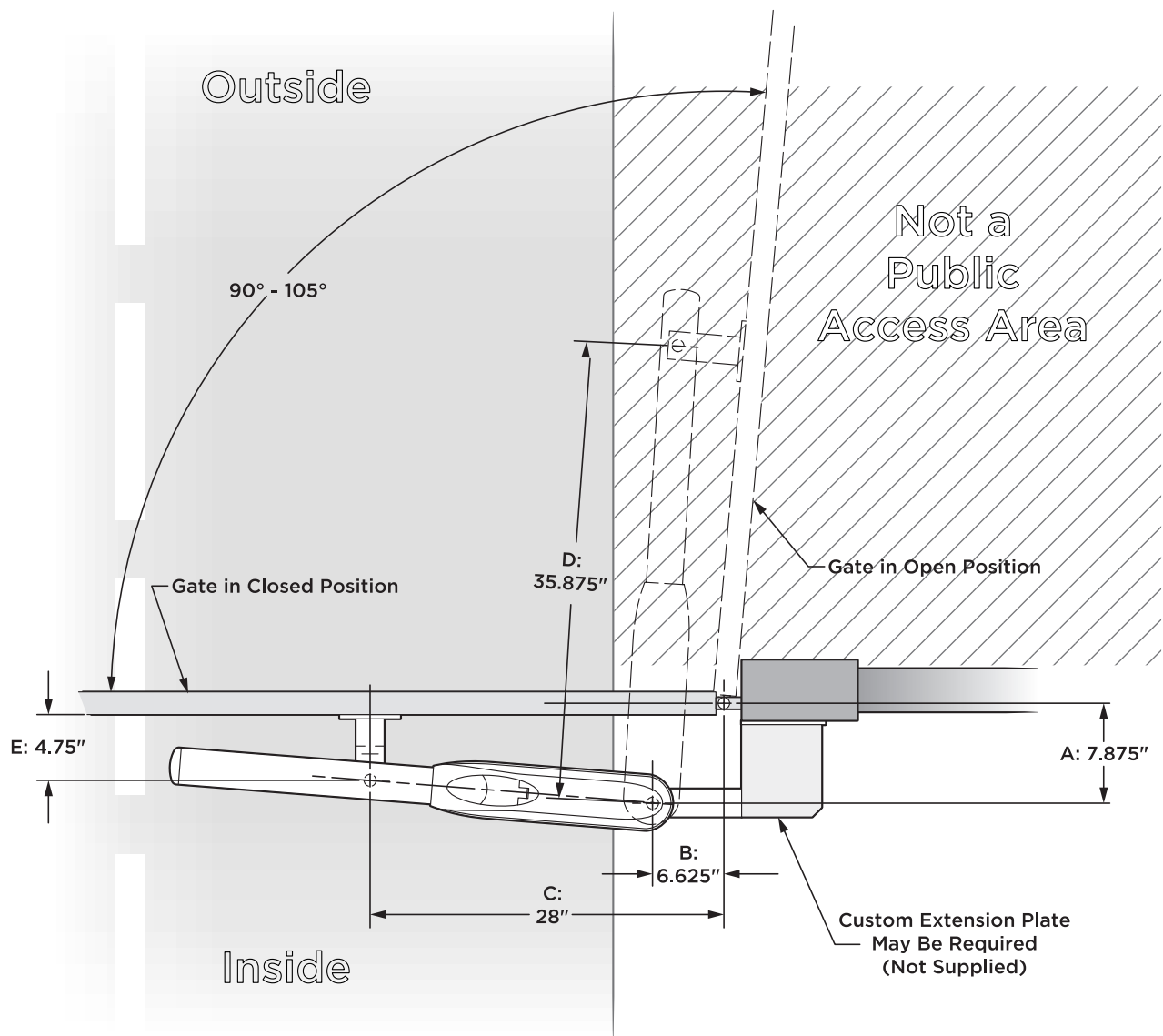

⚠ Varying from the dimensions provided above may severely affect the speed and performance of the gate operator.

GATE OPERATOR INSTALLATION

Mounting the Gate Operator

⚠ Caution: If the Front Mounting Bracket is not attached to a frame member that runs the full length of the gate, the gate operator may damage the gate. **DO NOT** attach the bracket or backing plate to just a few pickets.

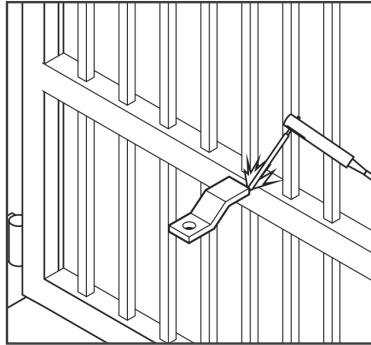

STEP 1

Front Mounting Bracket:

- Position the bracket according to the dimensions provided on pages 14 or 15.
- Ensure the bracket is level and tack weld in place.

⚠ TIP: Alternatively, if you choose to bolt this bracket to the gate, a backing plate has been provided with four bolt holes.

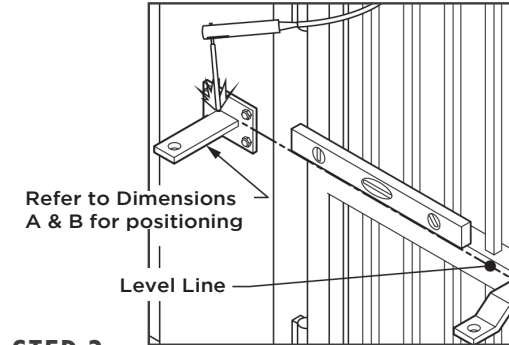

STEP 2

Back Mounting Bracket:

- Cut and position the bracket according to pages 14 or 15.
- Ensure the bracket is level and tack weld in place.

⚠ TIP: Alternatively, if you choose to bolt this bracket to the gate, a backing plate has been provided with four bolt holes.

STEP 3

Mount the Gate Operator:

- Install the operator onto the mounting brackets.
- Place the Manual Release Switch in the "Release" position. Refer to page 11.
- Manually move the gate to ensure the gate and operator moves freely.

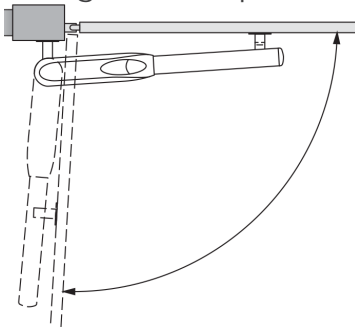

STEP 4

Complete the Installation:

- Dismount the operator.
- Complete the welding process.
- Lubricate the front bracket pivot point.
- Reinstall the gate operator and verify once again that the gate moves freely.
- Place the Manual Release Switch back to the "Engage" Position.

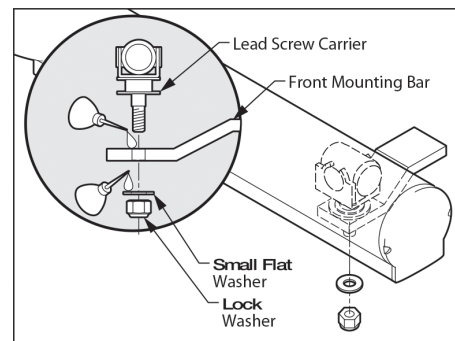

Post Mounting Option

Part # VA-G5PSKT Post Mount Kit is available for the G-5 Operator as an option to welding the operator Mounting Brackets.

- Mounting hardware provided for 3 1/2" round, 4" and 6" square posts.
- Mounting Brackets are powder coated 1/4" steel.

GATE OPERATOR INSTALLATION

Limit Switch Setup

STEP 1

Remove the Lead Screw Cover:

- Remove the cover mounting screw.
- Slide the cover off.

⚠ TIP: Leave the cover off until after the installation of the ECU Box and electrical installation. Verify that the operator opens and closes to the desired limit positions under power. Make any adjustments as necessary

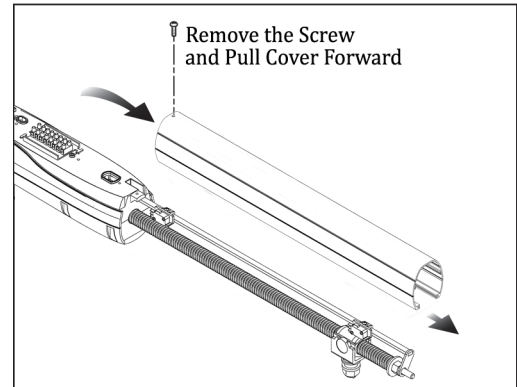

STEP 2

Position the Limit Switches:

- Loosen the setscrews on the Limit Switch Holders and slide the Limit Switches to the desired positions.
- Move the gate manually and ensure the Limit Switches are actuated (click) at the desired open and closed positions.
- Resecure the Limit Switch Holders when the proper position has been determined. DO NOT OVERTIGHTEN

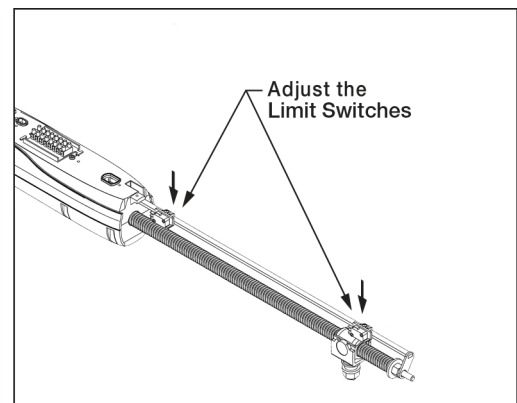

STEP 3

Positive Stop Collar:

- After the limit positions have been verified, partially open the gate and position the Positive Stop Collar as shown, with a 1/16" gap between the Collar and the Limit Switch Holder.
- Tighten the Collar EVENLY to secure.
- Run the gate two complete cycles and check that the Lead Screw Carrier makes firm contact to the Positive Stop Collar.

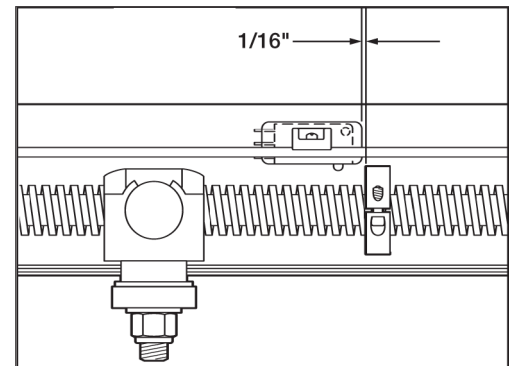

STEP 4

Reinstalling the Lead Screw Cover:

- Ensure that the End Cap is properly positioned over the tip of the Lead Screw as shown.

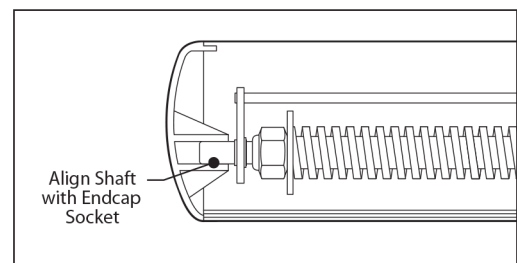

ECU BOX INSTALLATION

Mounting the ECU Box

⚠ WARNING: If the control box is not mounted properly it may fall, causing damage and/or injury. The Electronic Control Unit (ECU) weight is approximately 40 lbs. Be sure that the substrate being mounted to and the fasteners being used are appropriate to support the weight of the control box.

STEP 1

Disconnect the Siren, Stop Button and EMI Harness from the Control Board. Remove the Control Board Mounting Plate. The plate is held in the box by four screws.

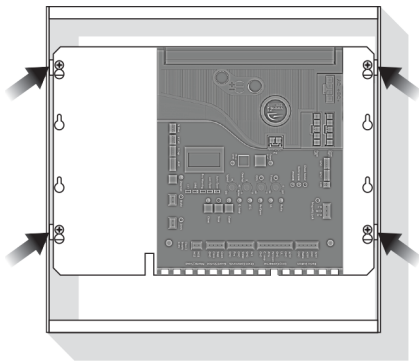

STEP 2

Position the ECU Box in the desired place and mark the mounting holes. Prepare the holes to receive the anchors/fasteners. NOTE: Anchors are Not Supplied.

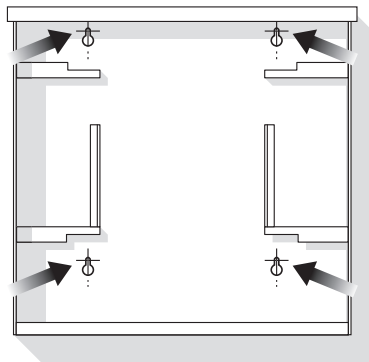

STEP 3

Position the ECU Box and secure it to the mounting surface using the Sealed Washers provided (rubber side of the washers against the inside of the control box).

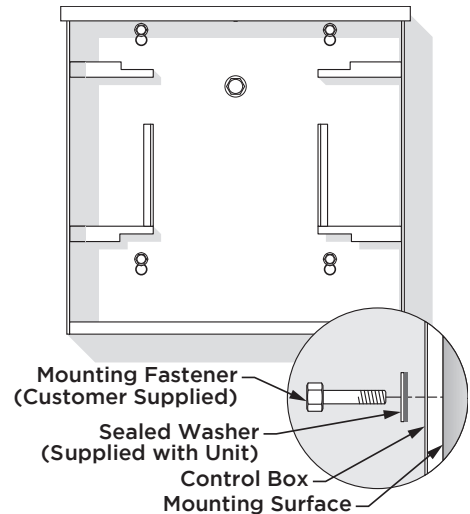

ELECTRICAL INSTALLATION

SAVE THESE INSTRUCTIONS - This manual contains important instructions for the ECUs model gate operator that shall be followed during installation and maintenance of the charge controller.

Battery Selection

- Battery is sold separately.
- Use only UL recognized 12V Sealed Lead Acid (SLA)
- 35Ah Maximum battery capacity.

Battery Care and Location

- Use at least 12AWG wire, rated 90°C or better.
- Two 7Ah batteries can be stored within the ECU's battery compartments.
- **Alternatively**, a 35Ah battery can be stored in a sperate BOX such as Viking part# VNxECUBB
- Ensure the battery terminals will maintain a 1/4" spacing from all other circuits and metal parts.
- Do not dispose of the battery in fire. The cells may explode. Check with local codes for possible disposal instructions.
- Do not open or mutilate the battery. Released electrolyte is corrosive and may cause damage to the eyes or skin. It may be toxic if swallowed.
- Exercise care in handling batteries in order not to short the battery with conducting materials such as rings, bracelets and keys.
- CAUTION - A battery can present a risk of electrical shock, burn from high short circuit current, fire or explosion from vented gasses. Observe proper precautions.
- Observe proper polarity orientation between the battery and charging circuit.

Solar Panel Selection

- Solar panel(s) are sold separately.
- Use only UL Listed 12V solar panel(s), such as Viking part #s:

Wattage	Viking Part#	Open-Circuit Voltage	Short-Circuit Current
20 Watts	VA-SO20W	21.7V	1.25A
40 Watts	VA-SO40W	21.8V	2.57A

Ratings

System Voltage:	12V	
Max. Solar Wattage:	40W	
Max. Solar Voltage:	29V	
Max. Battery Capacity:	35Ah	
Min. Battery Voltage:	8V	
Max. Charger Load Current:	3A	
Output Voltage for Controls:	24V	This is the voltage the control board will provide

⚠ Important: The number of cycles achieved daily is dependent on many factors, including current draw of the motor and accessories, and local solar radiation data. **If more specific information is needed please consult with Viking Access Systems. For more information regarding solar energy refer to: <http://rredc.nrel.gov/solar/pubs/redbook/>**

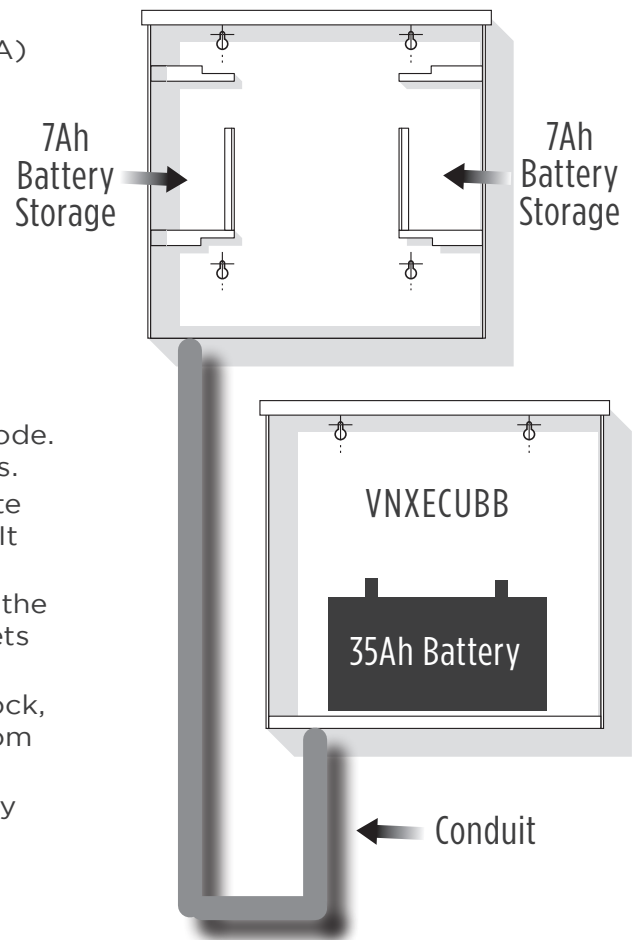

ELECTRICAL INSTALLATION

Solar Panel Care and Location

- Where it will receive maximum sunlight throughout the year.
- Avoid trees and buildings or obstructions, which could cast shadows on the panel.
- South facing and tilted at an inclined angle that is equal to latitude.
- If dirt build-up becomes excessive, clean the glass with a soft cloth using a mild detergent and water.
- Install solar panels in the following conditions:
 - Operating temperature: -40°F to 185°F
 - Humidity: Below 85RH%
 - Wind pressure: Below 50.12lb / ft² (2400Pa)
 - Snow load pressure: Below 112.76lb / ft² (5400Pa)
- DO NOT install the solar panel near open flames or flammable materials.
- DO NOT install the solar panel where there is a risk of being immersed in water or continually exposed to water from a sprinkle, fountain, etc..

Solar Panel Safety Precautions

- ⚠ Installation must be performed by a qualified technician.
- Before installing your system, contact local authorities and determine the necessary permit, installation and inspection requirements.
- Follow all local codes and guidelines.
- To reduce the risk of electrical shock or burns, the solar panel must be covered with an opaque material during installation.
- Do not touch live terminals with bare hands as they can present a risk of electrical shock, burn or fire.

Solar Panel Installation (per article 690 of ANSI/NFPA 70)

- Use appropriate methods to mount the solar panel. Fall of the panel from high places will cause death, injury or damage.
- The solar panel must be mounted on a post with a supporting structure to support wind and snow loads rated for use by the appropriate local or civil codes.
- Use stainless steel washers between the panel and the supporting frame to prevent electrolysis corrosion.
- Use conduit and the appropriate wire type for outdoor applications.
- Properly ground solar panel and operator according to NEC code.
- Use the appropriate wire size according to distance and the maximum power (Watt) rating of the solar panel, or panels combined.
- Use at least 16 AWG photovoltaic cable or 90°C, sunlight and moisture resistant direct burial cable or better.
- WARNING - This charge controller must be used with an external GFDI device as required by article 690 of the National Electric Code for the installation location.

Tips for proper ground installation:

- Use a ground rod to provide a ground reference.
- Consult your city code and be aware of under-ground services in the site of the gate operator to prevent inconveniences.
- Always use a single bonding point for grounding.
- All ground wires must be as short and as thick as possible.
- Prevent unnecessary turns or loops in all ground wires.

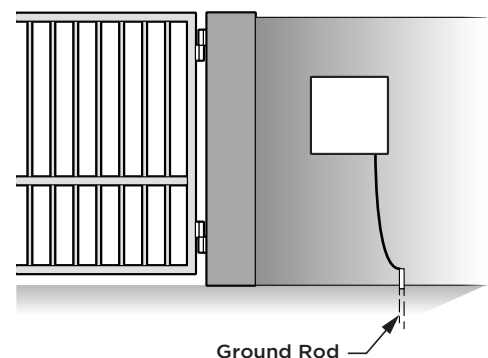

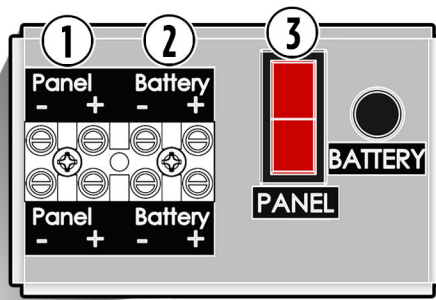
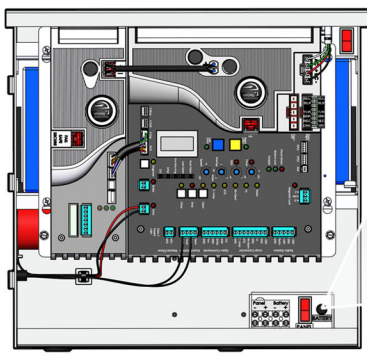

Power Connections

⚠ Caution: Ensure correct polarity

Step 1: Connect the 12V Solar Panel to the terminals labeled “PANEL”. ①

Step 2: Connect the 12V Battery to the terminals labeled “Battery”. ②

Step 3: Turn the “PANEL” switch to the “RESET” position. ③

Step 4: Turn the “POWER” Switch to the “RESET” position. ④

Step 5: Connect the Power Harness ⑤ and verify the “POWER” indicator ⑤a is illuminated solid.

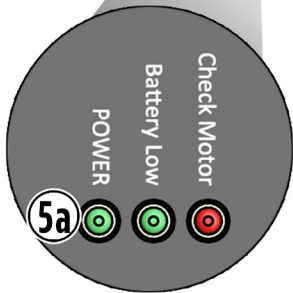
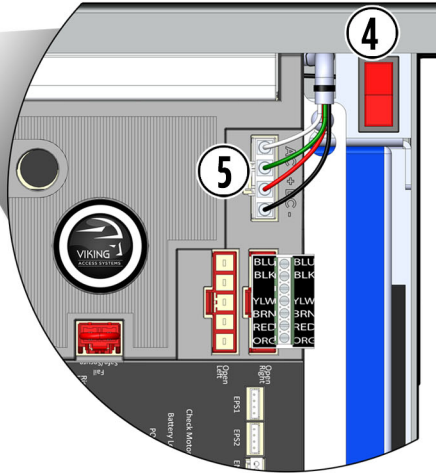
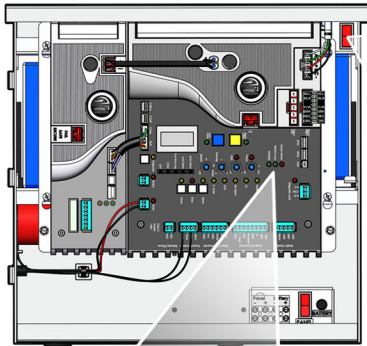

Power Saving Tip:

The solar VFlex “control board” shuts down the power at the “Aux. Pwr” Terminal ① when the board is in sleep mode.

To save energy, get the power for your non-essential devices (such as photo beams) from this terminal.

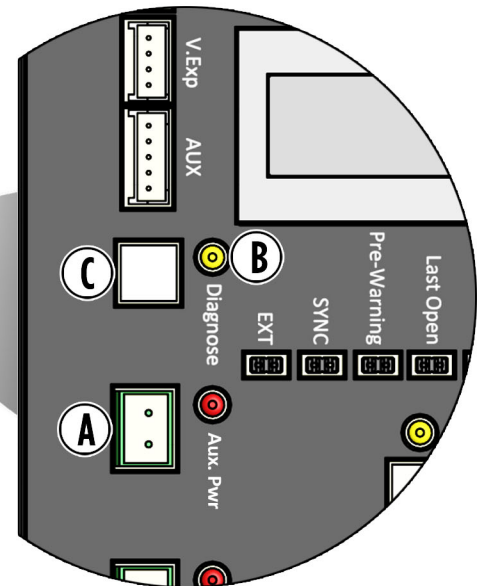
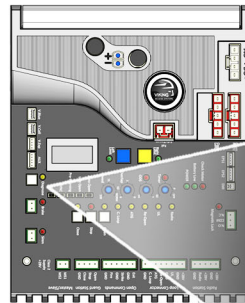

LCD Display References

Solar Related Error Messages

ER PANEL LOW	Indicates that the voltage being provided from the solar panel is too low.
ER PANEL HIGH	Indicates that the voltage being provided from the solar panel is too High.
ER SOLAR NO PANEL	Indicates that there is no voltage being provided from the solar panel.
ERR NO SOL UNIT	Solar board can't detect a solar gate operator.
ERR CHRG HIGH	Potential problem with the Solar Charger.
ERR BAT LOW	The battery is low

Diagnostics steps

If errors are detected the “Diagnose” indicator ② starts flashing.

Error messages will display automatically, otherwise press and release the “Diagnose” button ③ until the error messages appear.

ELECTRICAL INSTALLATION

Motor Cable - Master (Single)

NOTE: The Single Electronic Control Unit (VA-ECUSNX) is equipped to operate a single gate motor only, and does not include a Slave Module. The steps described on page 23 do not apply for this type of application.

STEP 3

Master Motor:

- Connect motor cable to the Motor Connector at the Master Control Board as illustrated, according to the printed color code.
- Attach the grounding wire, non insulated, to the Board Mounting Plate using the screw provided.

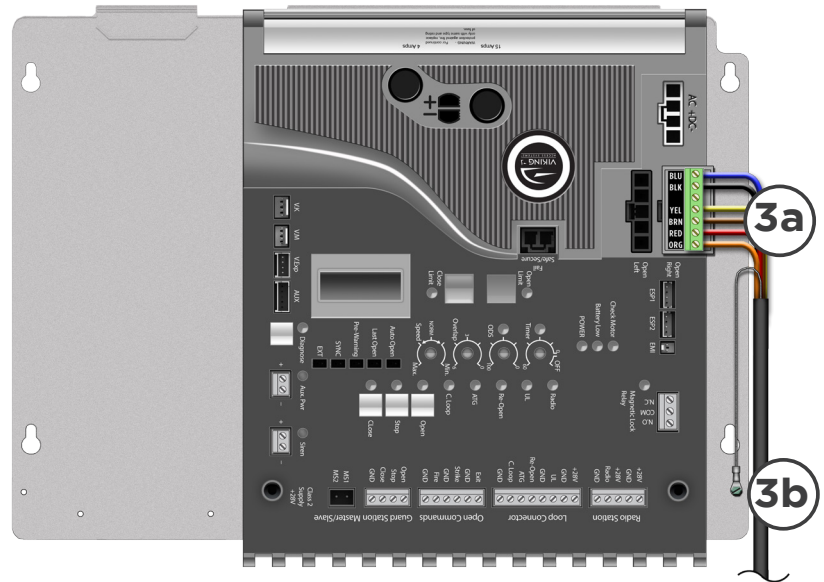

STEP 4

Master Open Left or Open Right:

Place the terminal block in the proper location for the gate opening direction.

- “OPEN RIGHT” Connector if the gate opens to the **INSIDE (pull to open)**.
- “OPEN LEFT” Connector if the gate opens to the **OUTSIDE (push to open)**.

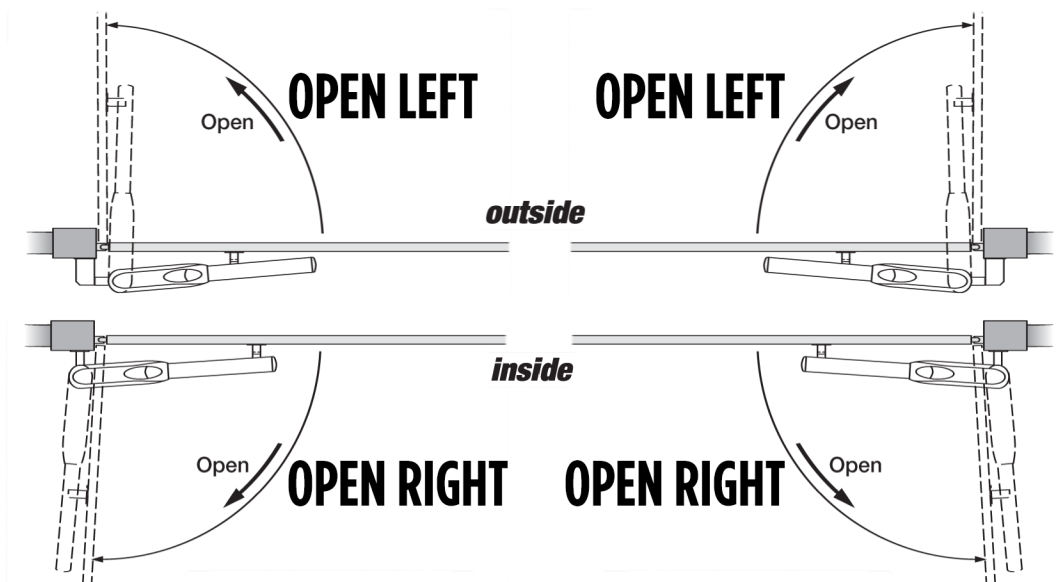

ELECTRICAL INSTALLATION

Motor Cable - Slave (Dual)

NOTE: The Master/Slave, or Dual, Electronic Control Unit (VA-ECUMSNX) is equipped with both the VFlex Control Board (Master) and a Slave Module, both are required to operate two gate motors in tandem.

STEP 5

Slave to Master Connections:

- Ensure that the Slave Power Harness is connected as illustrated. Polarity is important!
Red to “+” Black to “-”
- Ensure that the Master/Slave Communication Cable is connected as illustrated.

STEP 6

Slave Motor:

- Connect motor cable to the terminal block at the Slave Module as illustrated, according to the color code provided.
- Attach the grounding wire (non insulated) to the Board Mounting Plate using the screw provided.

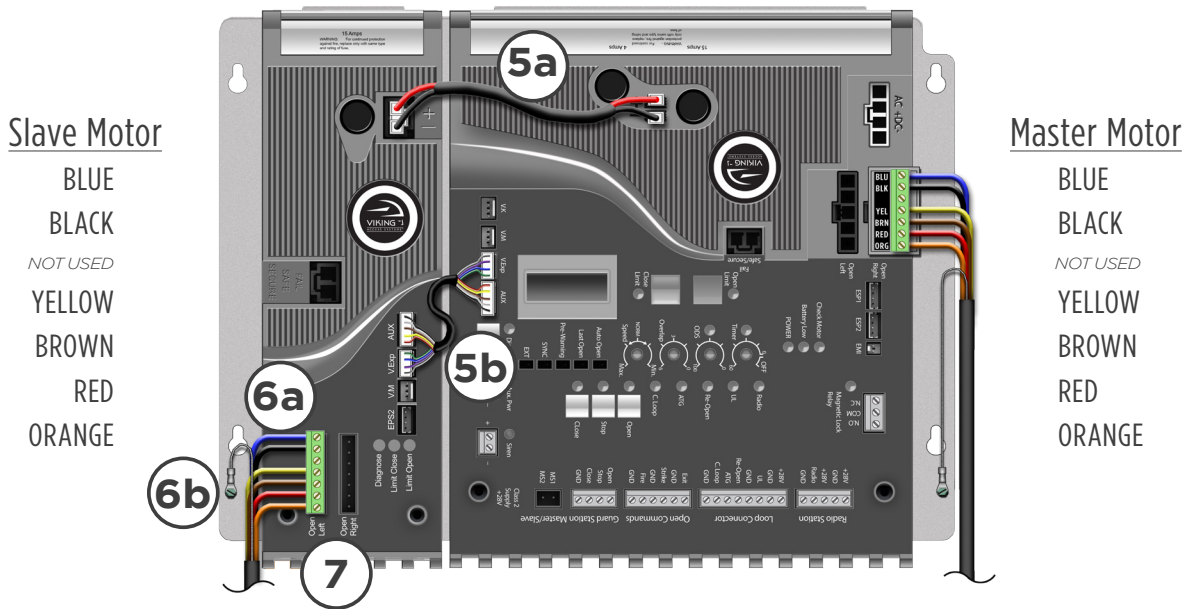

STEP 7

Slave Open Left or Open Right: Refer to the illustration on page 22.

Place the terminal block in the proper location for the gate opening direction.

- “OPEN RIGHT” Connector if the gate opens to the INSIDE (**pull to open**).
- “OPEN LEFT” Connector if the gate opens to the OUTSIDE (**push to open**).

LIMIT INDICATIONS

⚠ IMPORTANT: The gate operator uses mechanical limits. Therefore, the limits cannot be set electronically by this controller. The Limit Buttons on the control board have been rendered inactive by the controller. Refer to page 18 for specific instructions on how to set the limits for this gate operator..

⚠ TECHNICAL TIP: The Limit LEDs will illuminate solid when this operator reaches its corresponding limit. If both Limit LEDs are illuminated at the same time, this indicates that there is a problem with the limit switches or wiring.

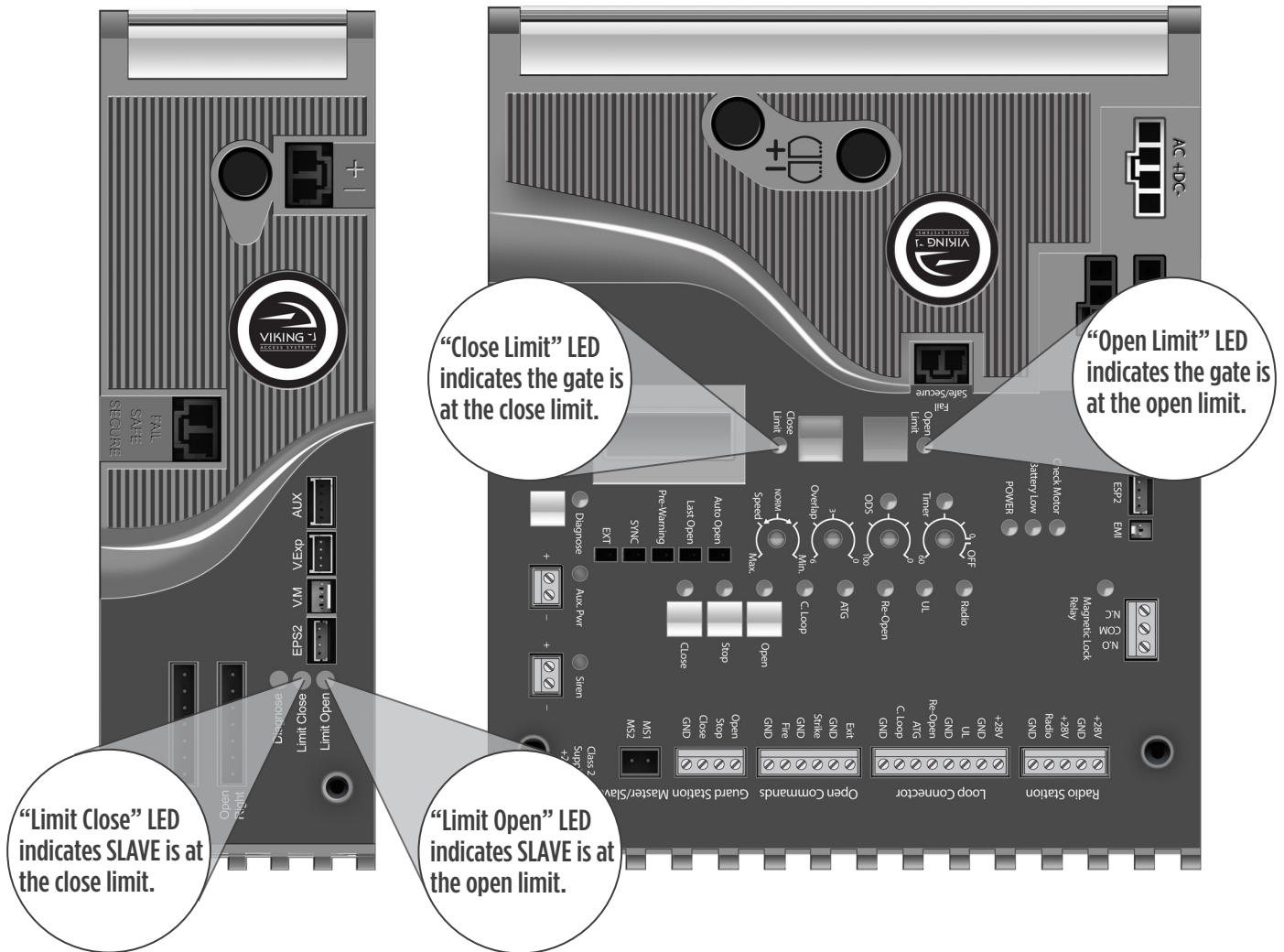

Reference Wiring Diagram

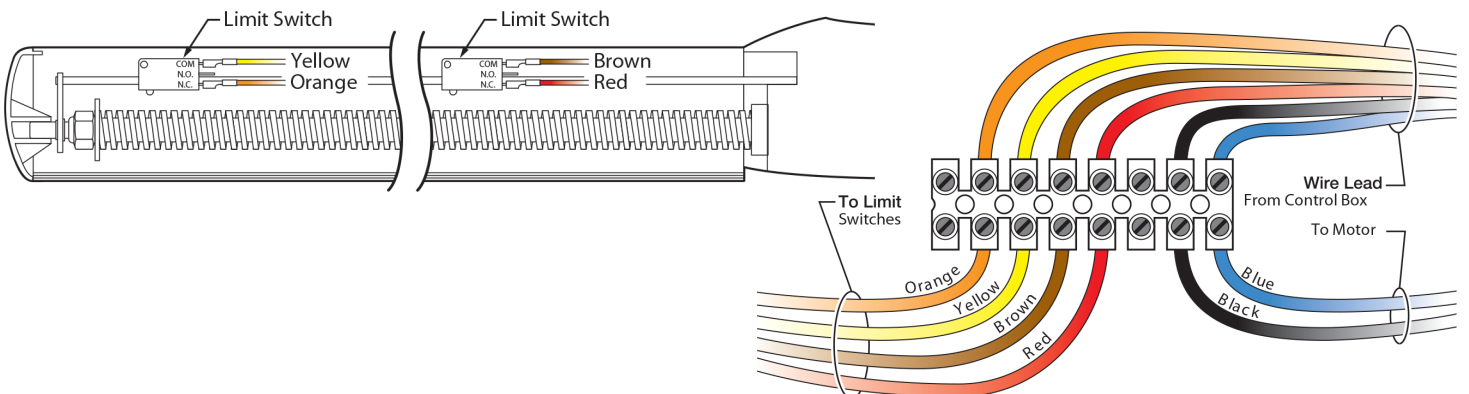

CONTROL BOARD SETUP

Initial Settings

“Speed” Motor Speed

Increases or decreases the speed of gate travel.

“ODS” Obstruction Detection Sensor

Sets the amount of force required to trip the inherent obstruction sensor.

Refer to page 27 for more details about this feature.

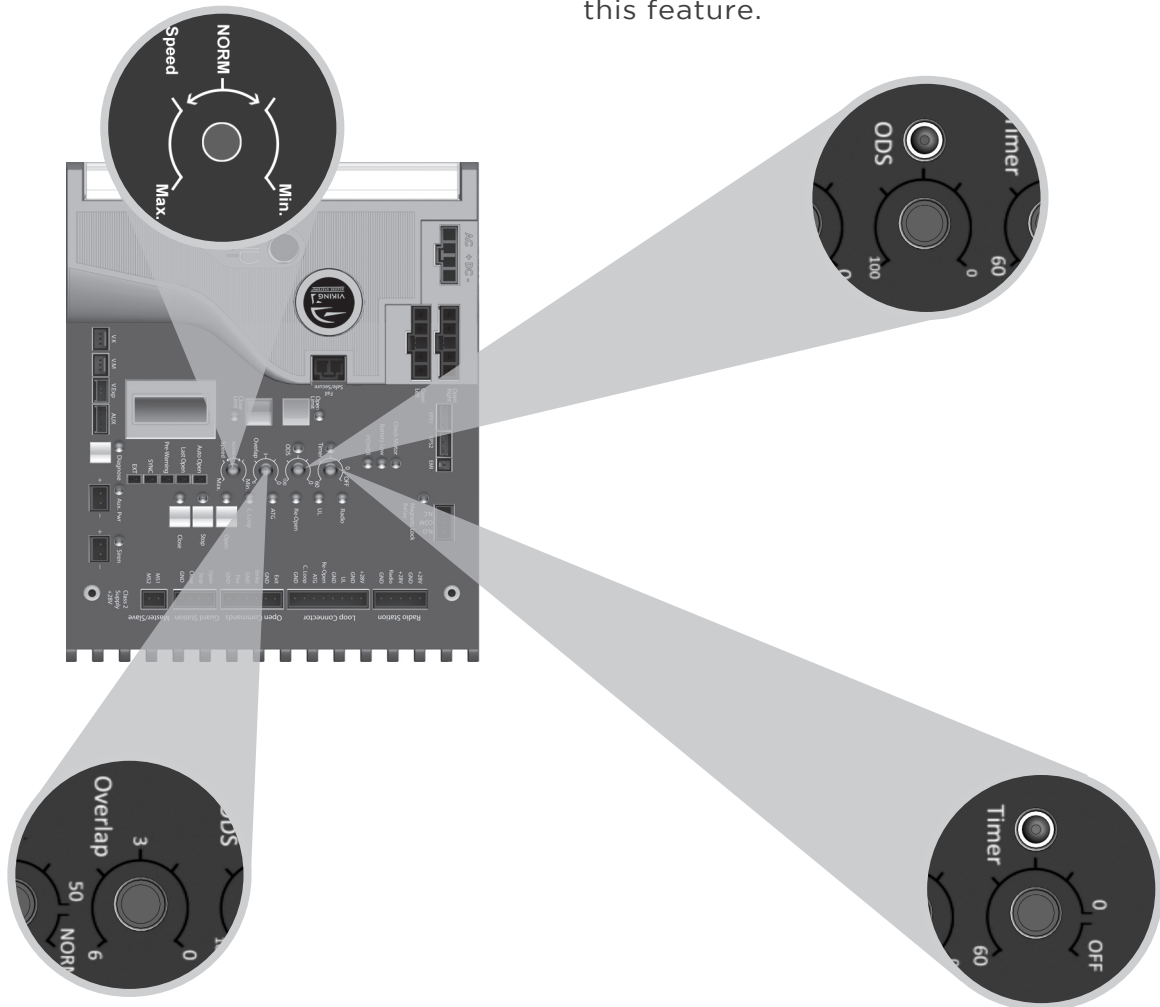

“Overlap” Overlap Delay

Delays the gate from opening for the selected amount of time from 1-6 seconds.

⚠ For Master/Slave or dual applications, the Master will delay to open and the slave will delay to close.

“Timer” Hold Open Timer

Automatically closes the gate after the selected amount of time from 1-60 seconds.

Turning the dial between “0” and “OFF” will disable this feature, requiring a close command to close the gate.

CONTROL BOARD SETUP

Initial Settings

NOTE: Installing a shunt, or jumper, on the pins will activate the feature.

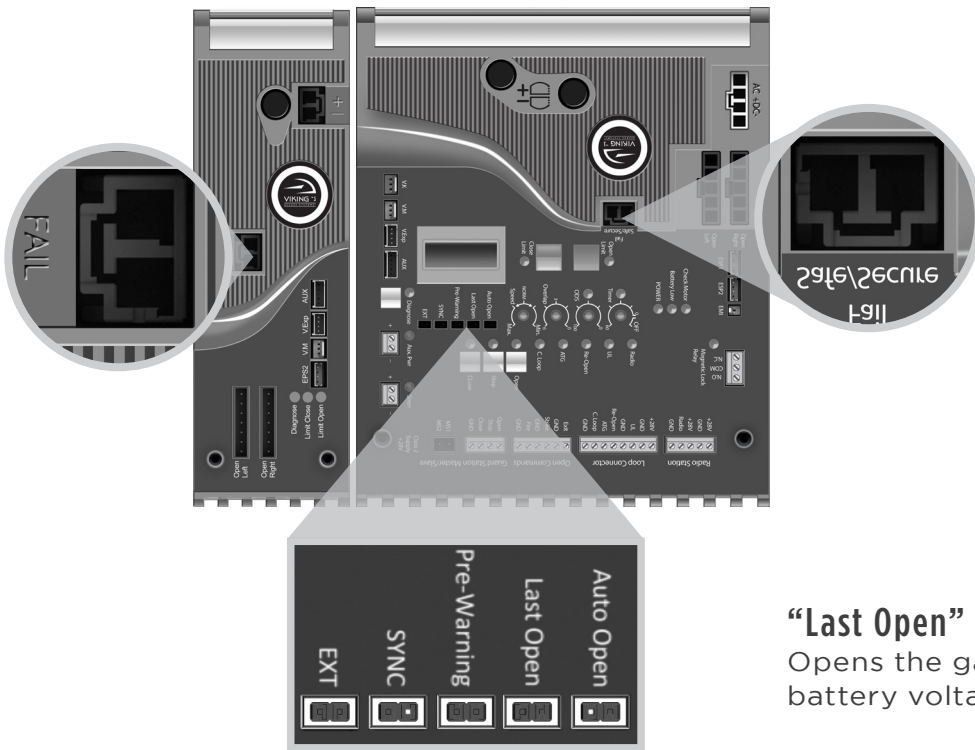

“Fail Safe/Secure”

During complete power failure, including battery power; determines the force required to manually move the gate.

- **Fail Safe Mode:**
By removing the wire-jumper plug from the “Fail Safe/Secure” connector:
The gate can move manually with a relatively low amount of force.
- **Fail Secure Mode:**
By inserting the wire-jumper plug into the “Fail Safe/Secure” connector:
The gate will not move manually.

“Last Open” - Power Failure Option

Opens the gate automatically when the battery voltage is critically low.

“Pre-Warning” Initiates two options for an audio or visual warning, 3 seconds prior to gate motion, and will continue:

1. **Until gate reaches closed limit:**
“Magnetic Lock” terminals provide a contact between “COM” and “N.O.”.
2. **Until gate reaches either limit:**
“AUX. PWR” terminals provide 24VDC.

“Sync” Used only in conjunction with the Viking Barrier gate operator model B-12. Activating this feature allows for synchronized operation with the B-12 operator. See page 33.

“EXT” Available for future developments.

CONTROL BOARD SETUP

Obstruction Sensor (Primary Entrapment Protection)

⚠ IMPORTANT: The appropriate “ODS” setting is dependant upon the gate installation and construction. Set this feature accordingly. Additional Safety equipment should be used to reduce possible risk of injury or vehicle damage.

“ODS” Obstruction Detection Sensor

The Obstruction Sensor detects obstructions in the path of the traveling gate. The dial sets the amount of force required to activate the operators inherent obstruction detection.

Setting the dial to “0” will require the least amount of force to activate;

Setting the dial to “100” will require the maximum amount of force to activate.

UL325 standard requires an audio alarm to go off after two consecutive entrapment events sensed by the Inherent Entrapment Protection of the Gate Operator.

The audio alarm will sound for a period of 5 minutes or until a Stop command or the “Alarm Reset” switch has been actuated. (refer to page 12)

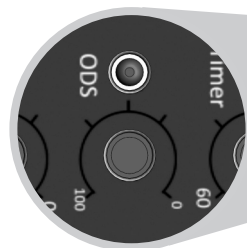
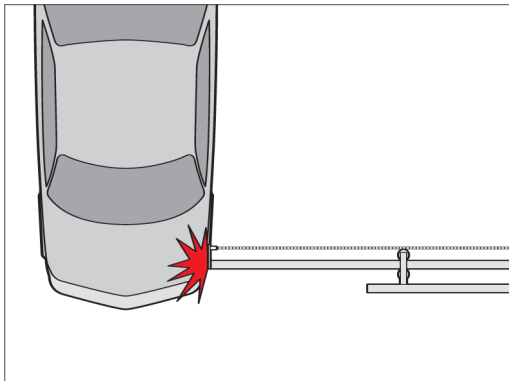

When the Obstruction Sensor detects an obstruction it will:

1. Stop the gate’s movement and reverse it momentarily.
2. Bring the gate to a resting position.
3. Disable the Hold Open Timer feature until the Gate Operator receives a new command.

If second obstruction is detected before the gate reaches either limit it will:

1. Stop the gate’s movement.
2. Disable the Gate Operator.
3. Sound the UL Alarm
4. A STOP command must be provided to disable the alarm and continue operation.

⚠ TECHNICAL TIP: The Status LED for the “ODS” will indicate the following when it has been triggered.

A. **Solid:** Obstruction.

Detected a sudden or abrupt increase in gate resistance.

B. **Flashing:** Overload.

Detected a more subtle, but sustained increase in gate resistance.

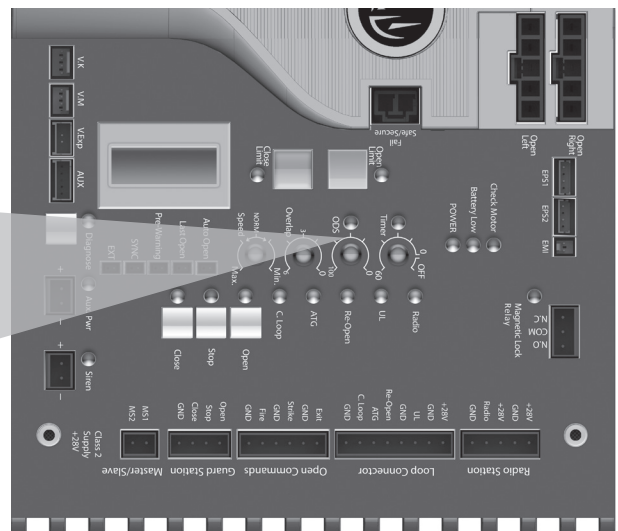

ACCESSORY CONNECTIONS

Re-Open Photo Beam (vehicular safety)

NOTE: This type of photo-beam installation will stop then RE-OPEN the gate all the way to the open limit when the beam is obstructed. Intended for vehicular safety ONLY. For the purpose of pedestrian entrapment, see pages 10-11 and 43.

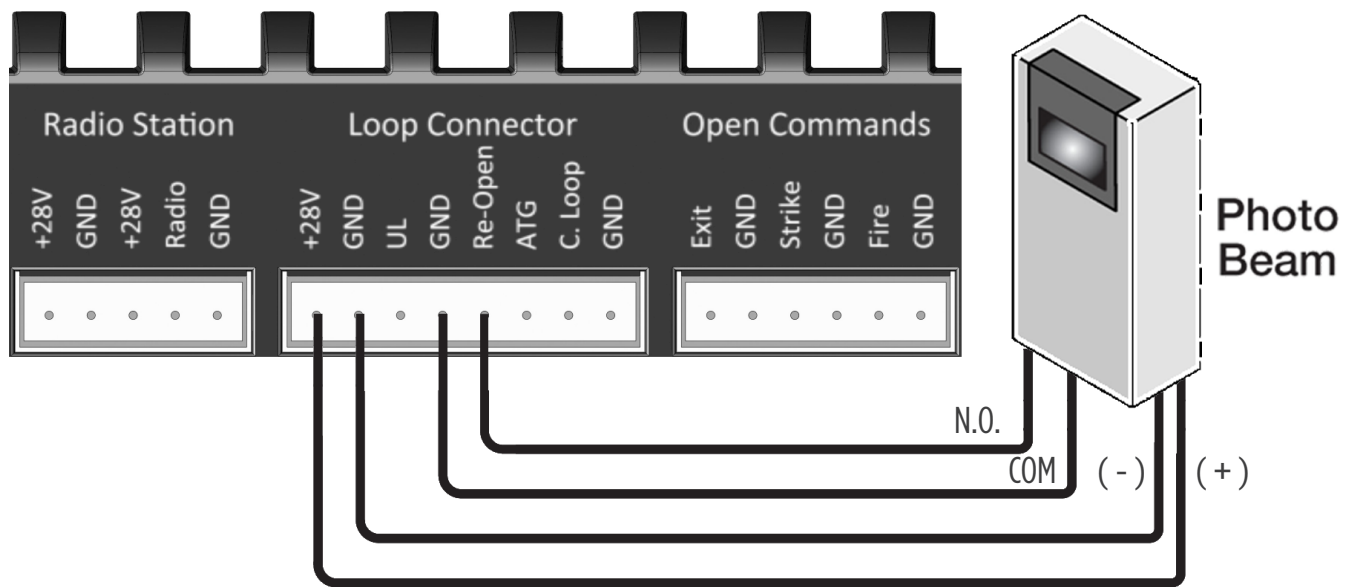

Power Saving Tip:

To save energy, get the power for your non-essential devices (such as photo beams) from the “Aux. Pwr” terminal block. Detailed on page 21.

Note regarding Photo Beam types:

Fail-Safe type - connect the “**N.C.**” terminal of the photo beam to the “**Re-Open**” terminal on the control board. Typically, these are the reflective type photo beams.

Fail -Secure type - connect the “**N.O.**” terminal of the photo beam to the “**Re-Open**” terminal on the control board. Typically, these are the transmitter/receiver type photo beams.

Check for proper operation:

The “**Re-Open**” LED will illuminate solid while the beam is obstructed and remain off when the beam is unobstructed.

⚠ TECHNICAL TIP: For more information regarding accessory connections to the control board and individual input terminal functions, refer to “**Appendix (A)**”, pages 40-41.

ACCESSORY CONNECTIONS

Radio Receiver (Typical)

⚠ IMPORTANT: The Hold Open “Timer” setting (page 25) affects how the gate will respond to the radio receiver command.

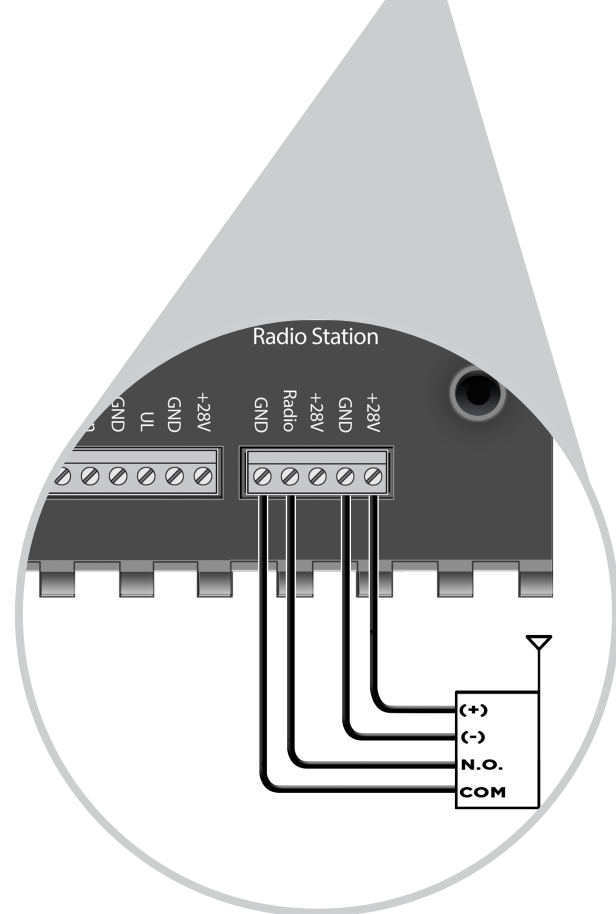
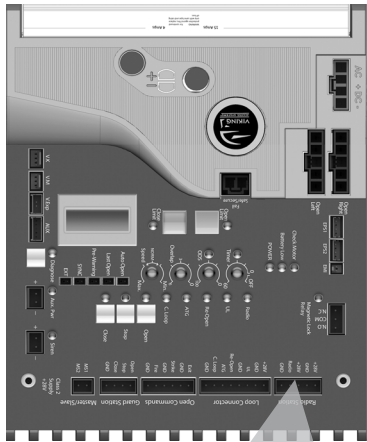

⚠ TECHNICAL TIP: For more information regarding accessory connections and terminal functions, refer to “Appendix (A)” on pages 40-41.

See “Appendix (B)” on page 42 for connecting common radio receiver models.

The control board provides two modes of operation that a radio receiver can control the gate:

Open-Stop-Close

1. By having the radio receiver connected as illustrated and with the Hold Open Timer OFF (see page 25):

Every command of the radio transmitter will control the gate as follows:

- First command opens the gate,
- Second command stops the gate and
- Third command closes the gate
- Any subsequent commands will continue in the same order to control the gate.

This type of configuration is not recommended for commercial installations.

Open Only

2. By having the radio receiver connected as illustrated and with the Hold Open Timer ON (see page 25):

Each command of the radio transmitter is **ALWAYS AN OPEN COMMAND** to the gate.

For maximum reception range:

Locate the radio antenna to the top of the gate column.

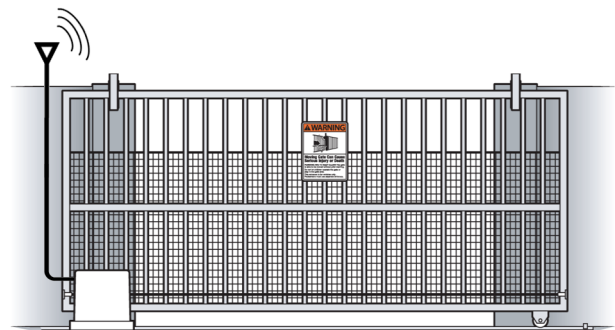

ACCESSORY CONNECTIONS

Anti-Tailgate, Open Commands & Guard Station

⚠ TECHNICAL TIP: For more information regarding accessory connections and terminal functions, refer to “Appendix (A)” on pages 40-41.

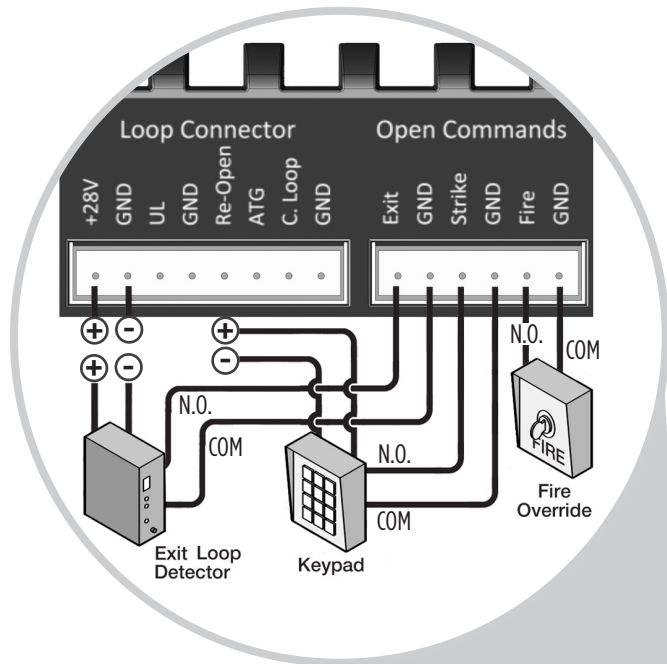

Open Commands

“Exit”, “Fire” and “Strike” input terminals all provide an open command to the control board. Any device connected as shown will open the gate.

Guard Station

⚠ All three buttons must be a Normally Open “N.O.” type of switch, and can share the same common “C” connection to “GND”.

“ATG” Anti-Tailgate

This input will stop the gate when the vehicle triggers the sensor, then closes the gate when the vehicle leaves the sensor, preventing unauthorized vehicles from entry.

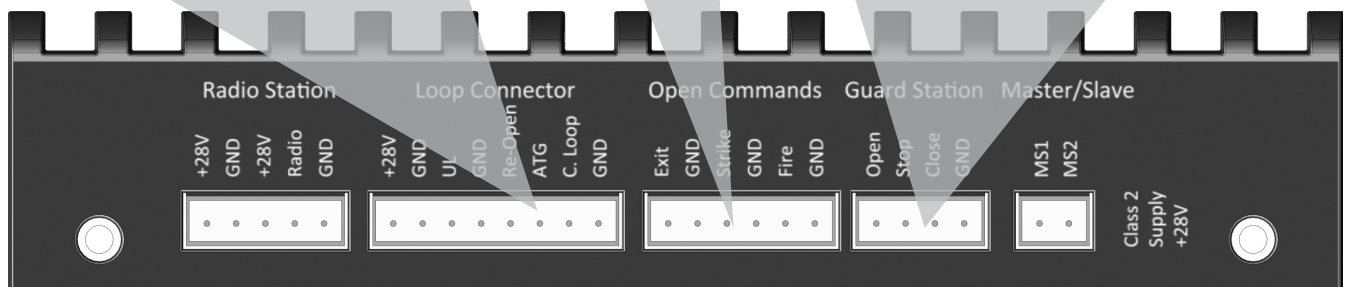
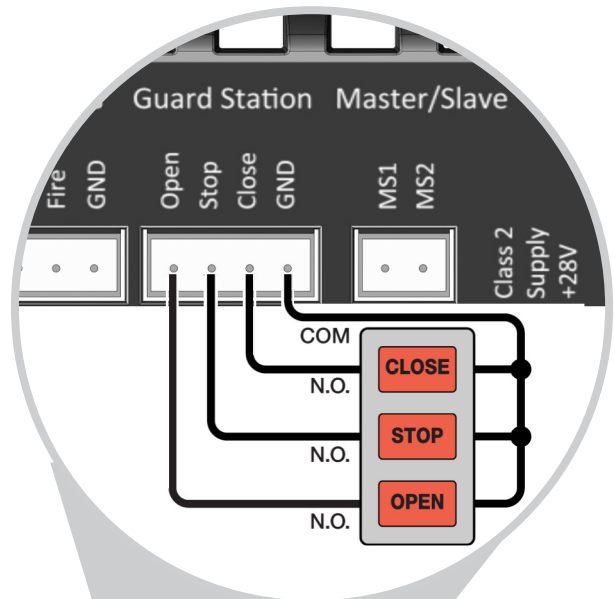
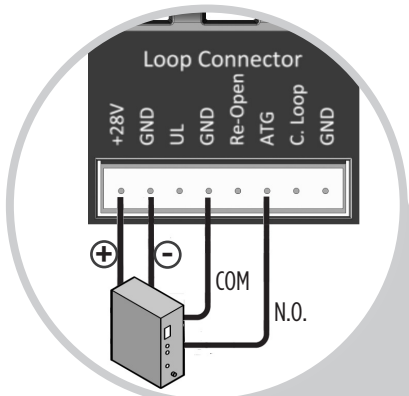

ACCESSORY CONNECTIONS

Viking Loop Rack

TIP: This operator may be equipped with a pre-wired **Loop Rack** that plug-in type loop detectors can be connected to. This provides a convenient alternative to the box type loop detectors that would need to be wired to the control board. Viking does not provide either type of loop detectors.

Loop Rack: Part # VA-LR

Loop Rack Wiring Harness: Part # VA-LRH

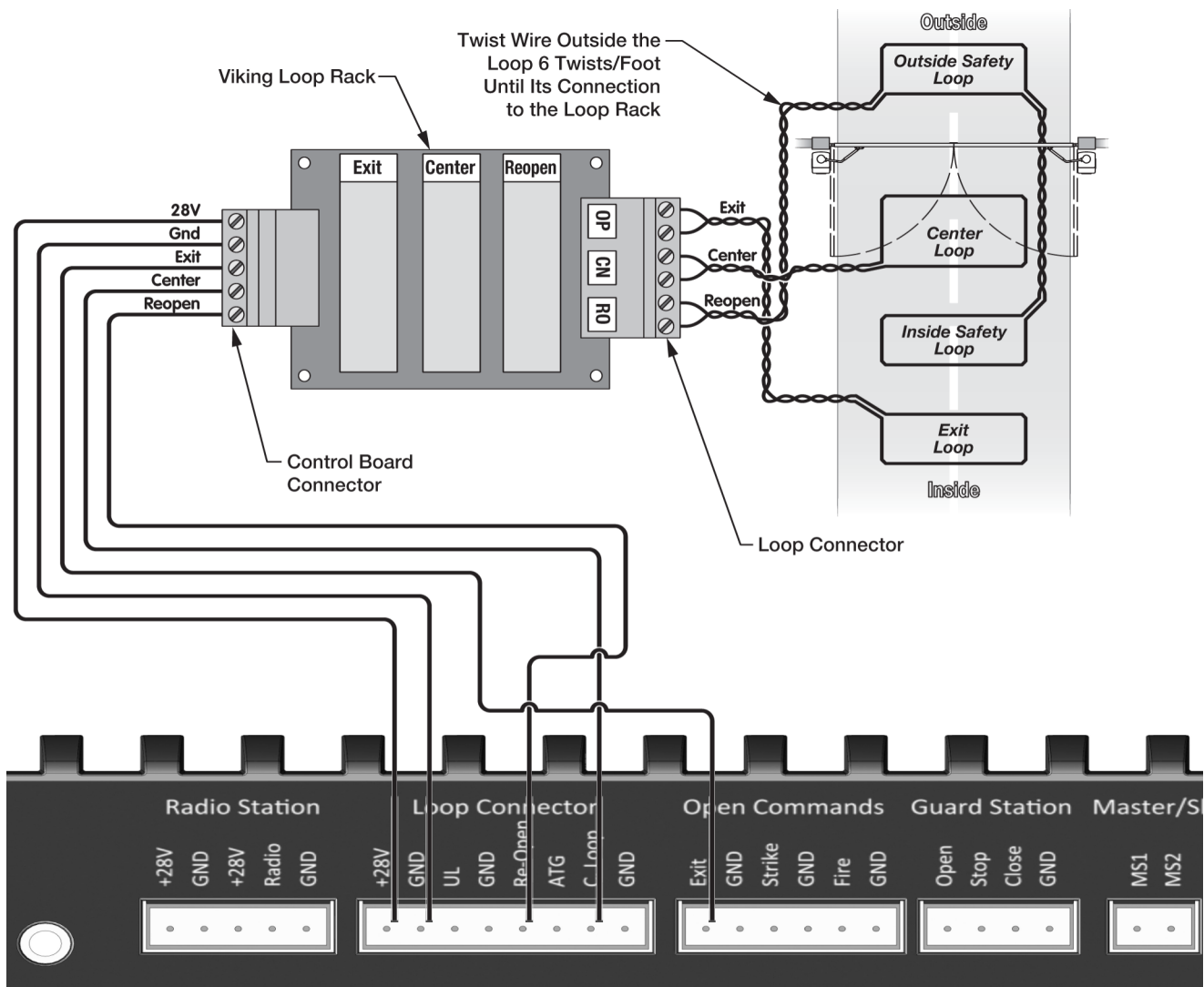

ACCESSORY CONNECTIONS

Guidelines for Loop Installation

1. Prevent sharp corners in the geometry of the loop sensor.
2. Install the appropriate number of turns for your loop geometry based on the loop perimeter. Use Table C (below) as a guide.
3. Use XLP (cross-linked-polyethylene) type of wire. This wire reduces the effects of moisture and other environmental events in altering the functionality of the vehicular loop detector.
4. Twist the lead wire at least 6 turns per foot.
5. Use BACKER-ROD to minimize damage to the loop detector wire prior to using the sealant.
6. Place the loop detector wire and adjust the sensitivity of the vehicular loop detector unit in a way to minimize the effects of the gate over the loop detector wire.

⚠ IMPORTANT! Some of the following parameters may affect the proper functionality of the vehicular loop detector.

Consult the manufacturer of the vehicular loop detector and/or loop wire.

- Gate size
- Number of turns in the loop sensor wire
- Distance of the loop sensor wire to the gate at either at the open or close position

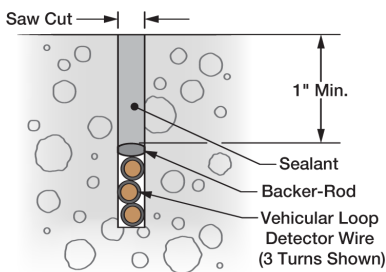
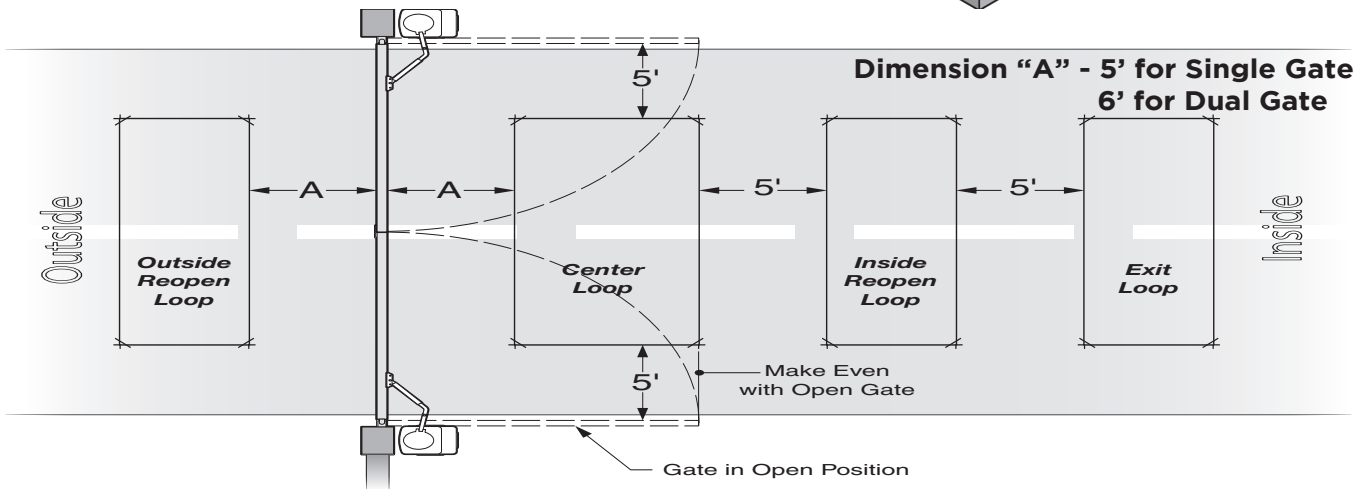
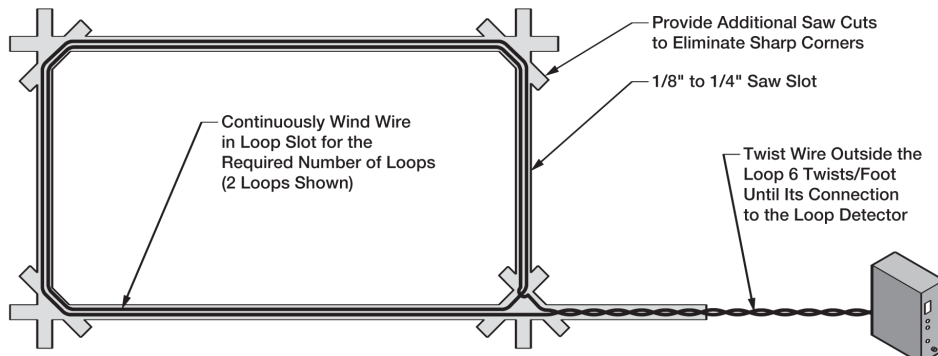

Table C - Recommended Number of Turns

Perimeter (ft.)	Number of Turns
10	5
20	4
30-40	3
50-100	2



SYNCHRONIZATION WITH B-12

Barrier Arm (B-12) Synchronization Option

NOTE: The Control Board provides a convenient solution for applications that require synchronized operation with the Viking Barrier Arm Operator model B-12.

This type of application opens and closes in the following pattern:

1. Open Command is provided only to the Viking B-12 Barrier Arm Operator.
2. The Barrier Arm will delay to open until this Gate Operator reaches its Open Limit.
3. The Gate Operator will delay to close until the Barrier Arm reaches its Close Limit.

STEP 1 (Figure A & B)

Connect the Gate Operator to the Viking B-12 Barrier Arm Operator as illustrated.

STEP 2 (Figure A)

At the B-12 Barrier Arm Operator, connect the primary device that will be used as the OPEN input.

STEP 3 (Figure B)

On the Gate Operator Control Board, activate Sync Mode by placing a jumper on to the pin headers labeled "SYNC".

Figure A

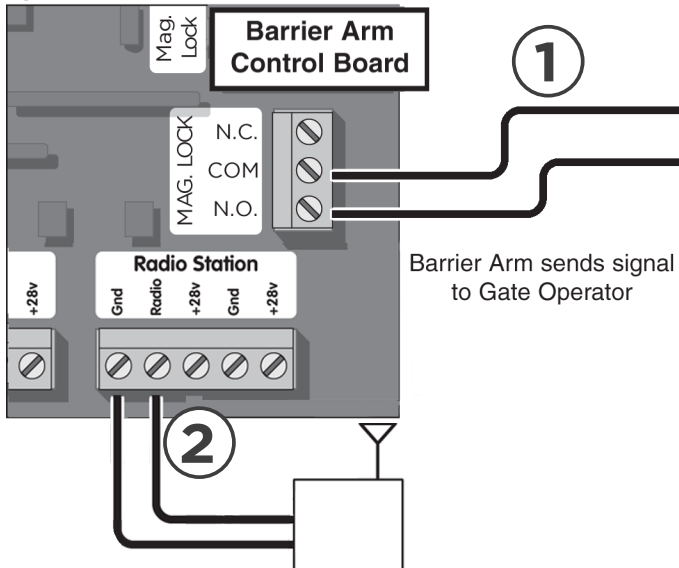
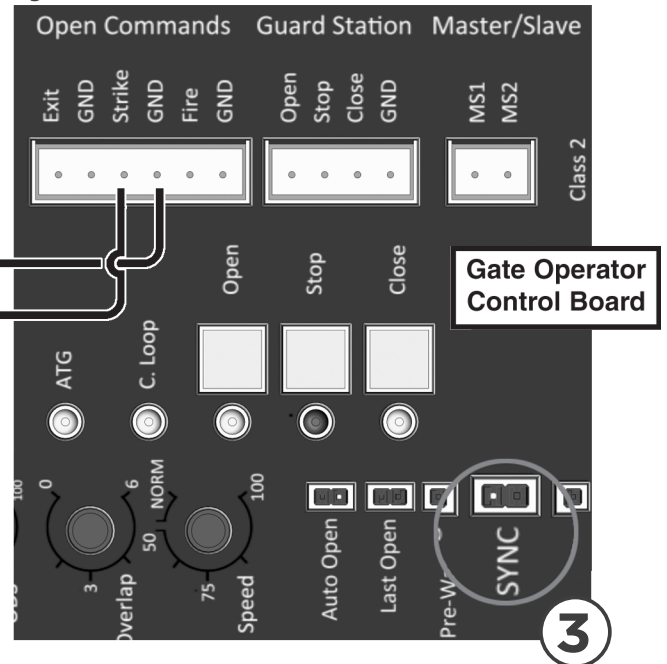

Figure B



STEP 4 (Figure C & D)

Connect Viking B-12 Barrier Arm Operator to the Gate Operator as illustrated.

Figure D

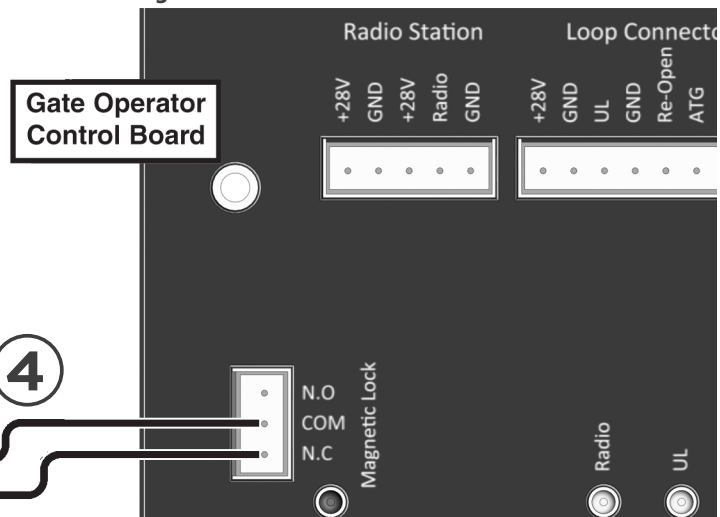
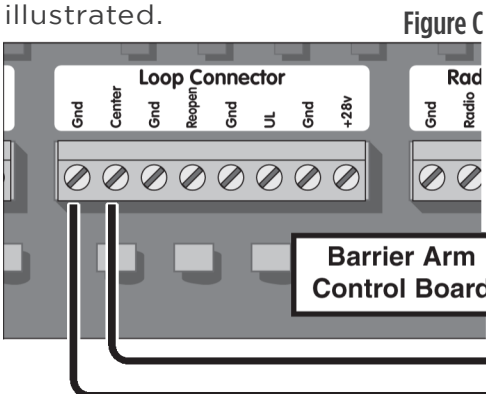

TROUBLESHOOTING

#	LED	Status	Meaning	TS Ref#(s)
9	“C Loop”	OFF	Normal Condition.	
		SOLID	An input from a device connected to the C Loop terminal (pg 31, 40)	9, 10
10	“Open”	OFF	Normal Condition.	
		SOLID	An input from a device to Exit, Fire, Strike or Open terminal (pg 30, 40)	9, 10
11	“STOP”	OFF	Normal Condition.	
		SOLID	Control Board is receiving an input from a device connected to the Stop terminal (pg 12, 30, 40).	9, 10
		FLASHING	There is a problem with the required monitored sensor(s) connected to the “UL” input terminal (pg 10-11)	16, 22
12	“Close”	OFF	Normal Condition.	
		SOLID	An input from a device connected to the Close terminal (pg 30, 40)	9, 10
13	“Siren”	OFF	Normal Condition.	
		SOLID	Second consecutive obstruction has been detected. (pg 25, 27)	11, 13
		FLASHING	Batteries are critically low.	
14	“Aux. Pwr”	OFF	No voltage output on these terminals at the moment.	
		SOLID	There is 24VDC output on these terminals at the moment.	
15	“Diagnose” (master)	OFF	Normal Condition	
		FLASHING	Errors have been detected; Check LCD Display for ERR messages (pg 38)	
16	“Close Limit” (master)	OFF	Gate is not at the close limit position.	
		SOLID	Gate is at the close limit position.	
		FLASHING	Indicates a problem with the limit switches or wires.	6
17	“Open Limit” (master)	OFF	Gate is not at the open limit position.	
		SOLID	Gate is at the open limit position.	
		FLASHING	Indicates a problem with the limit switches or wires.	6
18	“ODS”	OFF	Normal Condition.	
		SOLID	Obstruction event has been detected on the MASTER motor. (pg 25, 27)	11, 13
		FLASHING	Overload event has been detected on the MASTER motor. (pg 25, 27)	11, 13
19	“Timer”	OFF	If gate is at the open limit, the Timer to close is turned OFF. (pg 25)	
		SOLID	Timer to close is ON and counting down to close the gate. (pg 25)	
		FLASHING	Timer is ON but is not timing out due to a conflicting command. (pg 25)	9, 10
S1	“Diagnose” (slave)	OFF	Normal Condition	
		FLASHING	Errors have been detected; Check LCD Display for ERR messages. (pg 38)	
		SOLID	Obstruction event has been detected on the SLAVE motor. (pg 25, 27)	11, 13
		RAPID FLSH	Overload event has been detected on the SLAVE motor. (pg 25, 27)	11, 13
S2	“Limit Close” (slave)	OFF	Slave gate is not at the close limit position.	
		SOLID	Slave gate is at the close limit position.	
		FLASHING	Indicates a problem with the limit switches or wires on the slave operator.	6
S3	“Limit Open” (slave)	OFF	Slave gate is not at the open limit position.	
		SOLID	Slave gate is at the open limit position.	
		FLASHING	Indicates a problem with the limit switches or wires on the slave operator.	6

TROUBLESHOOTING

LCD Display References

The control board is equipped with a LCD Display that provides operator information, current conditions, settings, diagnostics and error messages. Use the table below to identify the corresponding “TS Ref#” and refer to page 39 for further troubleshooting.

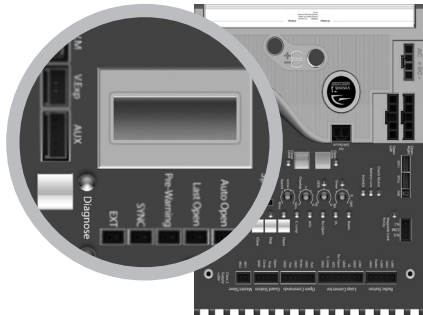

1. Error Messages will be displayed first.
2. The “Diagnose” LED will flash consecutively indicating how many Error Messages are available.
3. Press the Diagnose button to manually scroll through all of the Messages.

Page 39
TS Ref #s

LCD MSG	Meaning	
MODEL G55/X95	Indicates the Model of the unit. G-5 or X-9 Solar.	
System Status Messages		
GATE IS IDLE	Gate is stopped between limits.	
GATE IS OPENING	Gate is opening.	
GATE IS CLOSING	Gate is closing.	
GATE IS OPENED	Gate is at the limit open position.	
GATE IS CLOSED	Gate is at the limit close position.	
STOP BY OBSTRUCT	Master or Single motor has stopped due to an obstruction of the gate system. Also refer to the “ODS” LED. (pg 27, 34, 35 @ 18)	11, 12, 13
STOP BY OVERLOAD	Master or Single motor has stopped due to an overload of the gate system. Also refer to the “ODS” LED. (pg 27, 34, 35 @ 18)	11, 12
OVERLAP TIMING	Gate is waiting for the overlap time.	
HOLDING __ SEC	Gate is at the limit open position and timing to close - The display shows the actual time left before closing.	
STOP BY ODS S	Slave motor has stopped due to an obstruction sensor event. Also refer to the “DIAGNOSE” LED on the Slave Module. (pg 27, 34, 35 @ S1)	11, 12, 13
UL LEARN SENSOR _	Indicates the number of connected Secondary Entrapment Protection Sensors that are being monitored through the UL input terminal. (pg 11)	

LCD Display References

LCD MSG Meaning

Multi Meter Displays

MOT AMP
---- A This is the motor current amperage during operation.

MOT VOLT
---- VDC This is the actual motor voltage during operation.

SOL VOLT
---- VAC This is the actual voltage from the solar panel.

CHARGE
---- VDC Indicates the voltage being supplied to the Control Board from the Viking Solar Charger.

BAT VOLT
---- VDC This is the actual voltage from the Battery

Board Settings Messages

SPEED
...% Shows the percentage of speed set by the Speed adjustment on the control board. (pg 25)

OVERLAP
... SEC Shows the number of seconds set by the Overlap Adjustment on the control board.

ODS SENS
----% Shows the force setting selected to trip the obstruction sensor. (pg 25, 27)

TIMER
... SEC Shows the amount time set or remaining to hold the gate at the Open Limit position, before the gate starts to close. (pg 25)

TROUBLESHOOTING

LCD Display References

Page 39
TS Ref #s

LCD MSG	Meaning	
Error Messages		
ER PANEL LOW	Indicates that the voltage being provided from the solar panel is too low.	?
ER PANEL HIGH	Indicates that the voltage being provided from the solar panel is too High.	?
ER SOLAR NO PANEL	Indicates that there is no voltage being provided from the solar panel.	?
ERR NO SOL UNIT	Solar board can't detect a solar gate operator.	?
ERR CHRG HIGH	Potential problem with the Solar Charger.	?
ERR BAT LOW	The battery is low	?
ERR FUSE 15 AMP	15 Amp motor fuse is blown on the Master or Single Control Board.	7, 11, 12
ERR FUSE 15A S	15 Amp motor fuse is blown on the SLAVE Module.	7, 11, 12
ERR REFV WRONG	One, or more, of the internal reference voltages from the VFlex (Master) Control Board are incorrect.	?
ERR UL SENSOR	There is a problem with the required monitored sensor(s) connected to the "UL" input terminal (pg 10-11).	22

TROUBLESHOOTING

Solutions

Begin the troubleshooting process by referring to the error messages on the LCD Display and/or the Status LEDs on the control board. Use pages 32-36 to identify the Troubleshooting Reference # (TS Ref#) then reference the table below.

TS Ref#	CHECK	Page Ref#
1	Not applicable to this model.	
2	Not applicable to this model.	
3	Not applicable to this model.	
4	Not applicable to this model.	
5	Check that the Power Harness is connected to the control board.	pg 4, 25
6	Check that the limit circuits are Normally Closed (N.C.). Check the limit switch.	pg 4, 17, 22-23
7	Check the Motor Fuse on the control board.	pg 4
8	Check that the operator is not in Manual Release mode.	pg 11
9	Check the Status LEDs and LCD Display to determine if the control board is receiving an input from any external devices or if the "ODS" has been triggered.	pg 25, 27 34-36
10	Remove the external devices from the control board to determine if the control board is responding to an input or problem with the external device or wiring.	pg 28-31, 34-35
11	Check the "ODS" setting on the control board.	pg 27
12	Check that the gate can be moved manually with low resistance throughout its full range of motion.	pg 8
13	Check the limit position.	
14	Not applicable to this model.	
15	Not applicable to this model.	
16	Check the LCD Display for Error Messages.	pg 38
17	Not applicable to this model.	
18	Not applicable to this model.	
19	Manually adjust any setting on the Control Board to clear all wireless override settings.	
20	Not applicable to this model.	
21	Not applicable to this model.	
22	Check the secondary entrapment protection sensors connected to "UL" terminal.	pg 10-11
?	Call Viking Technical Support for further assistance.	

Appendix (A)

Access Control Connections

Power Connections

The control board provides a 24VDC output to power external devices and controls.

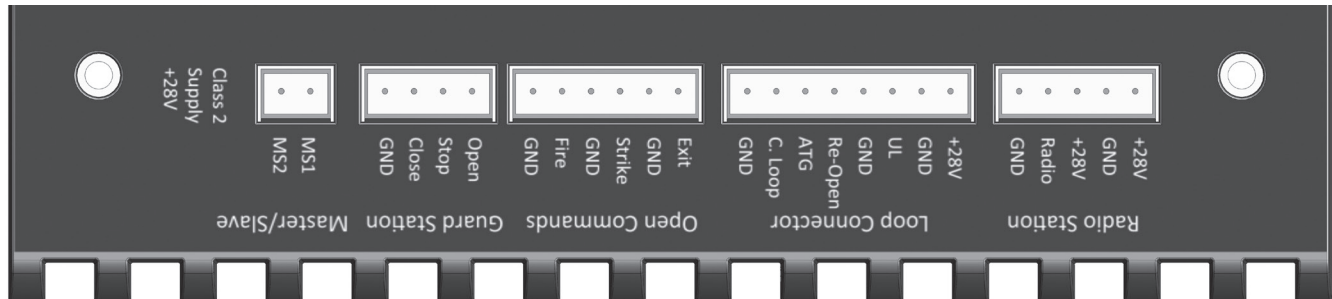

Terminals Connections and Input Functions:

“C”	=	Common
“N.O.”	=	Normally Open

Viking Terminal	Function	Device Terminal
“+28V”	DC Positive	“+”
“GND”	DC Negative	“-”
“GND”	Relay Common	“C”
“Radio”		“N.O.”
	If “Timer” OFF: If “Timer” ON:	Open - Stop - Close Open / Reopen if closing
“UL” (see pages 10 & 11)		“N.O.”
	If input is brief: If input is longer: If “UL ADV” is ON:	Stops gate then Reverses 12 inches Stops gate, does not reverse Stops then Opens gate
“Re-Open”		“N.O.”
	If stopped: If closing:	No function Stops then Opens gate
“ATG” Anti-Tailgate		“N.O.”
	Input is received: Input is released:	Stops gate if closing Closes gate to prevent tailgating
“C. Loop”		“N.O.”
	If not at open limit: If at open limit:	No function Prevents gate from Closing
“Open”, “Exit”, “Fire” & “Strike”		“N.O.”
	If stopped: If closing:	Opens gate Stops then Opens gate
“Stop”		“N.O.”
	If traveling:	Stops gate
“Close”		“N.O.”
	If stopped: If traveling:	Closes gate No function

⚠ TECHNICAL TIP: Each input Terminal (i.e. Radio, Exit, Re-Open, UL) has a corresponding Status LED that when illuminated indicates an input is currently being provided to the terminal and the gate is responding accordingly. (See pages 34-35 LED References)

Relays In General

NOTE: Viking Access Systems does not provide the external safety devices and access controls. These items can be purchased from your dealer or distributor.

In General

In regards to the Viking control board, all external safety devices and access controls contain, and are, simple relays that provide an input to the Viking control board when the device is activated.

When these devices are activated, their internal relays create a contact, or short, between the “C” and “N.O.” terminals. This contact is what provides the command to the Viking control board.

▲ TECHNICAL TIP: Viking uses the Normally Open “N.O.” contact from the device, excluding “fail-safe” type photo beams. In such instances, the Normally Closed “N.C.” will be used instead.

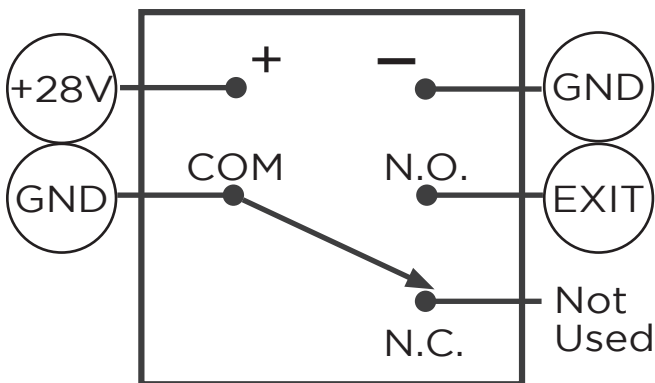

Glossary of Terms

- 1. Terminal:** Wire Connections.
- 2. Input Terminal:** On the Viking control board, the terminal which is labeled for a specific command (Re-Open, Exit, Radio, etc.). The N.O. contact from the access control device is to be connected to the Input Terminal.
- 3. Terminal Block:** On the Viking control board, a removable block containing multiple terminals.
- 4. Relay:** The component of an access control or safety device that provides an input or command to the Viking control board.
- 5. “C” Relay Common Terminal:** This is the relay terminal that makes contact (a short) to the N.O. terminal when the device is activated. *Always wire this relay terminal to any “GND” terminal at the control board.*
- 6. “N.O.” Relay Normally Open Terminal:** The relay terminal that has an open contact to “C” while the relay is not activated, and a closed contact when the relay is activated. *Almost always wire this relay terminal to an “Input Terminal” at the control board,*
- 7. “N.C.” Relay Normally Closed Terminal:** The relay terminal that has a closed contact to “C” while the relay is not activated, and an open contact when the relay is activated. *This terminal is rarely used.*
- 8. Relay Coil:** Contains the terminals that provide power at the relay.
- 9. “+” Relay Positive Terminal:** The positive power pole for the relay coil. *Always wire this relay terminal to any “+28v” terminal at the control board.*
- 10. “-” Relay Negative Terminal:** The negative power pole for the relay coil. *Always wire this relay terminal to any “GND” terminal at the control board.*

Appendix (B)

Common Radio Receivers - Connections

Multi-Code 1099

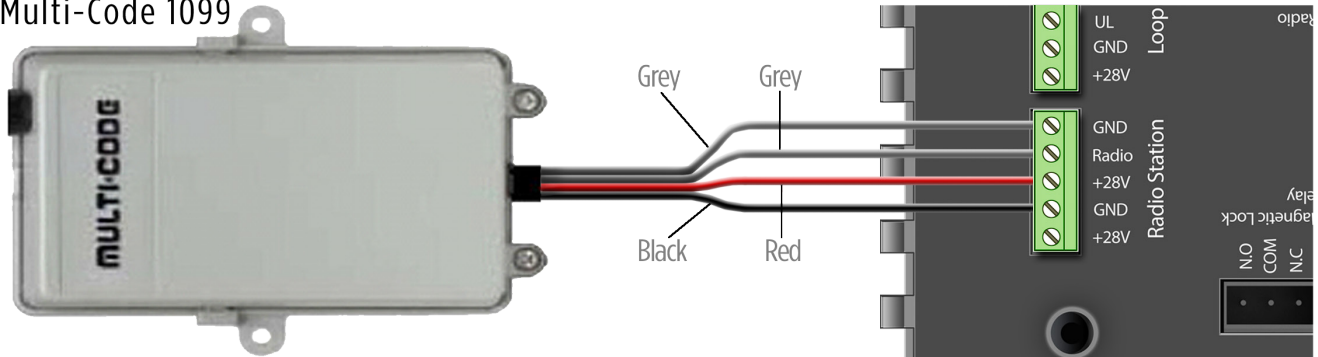

Multi-Code 1090

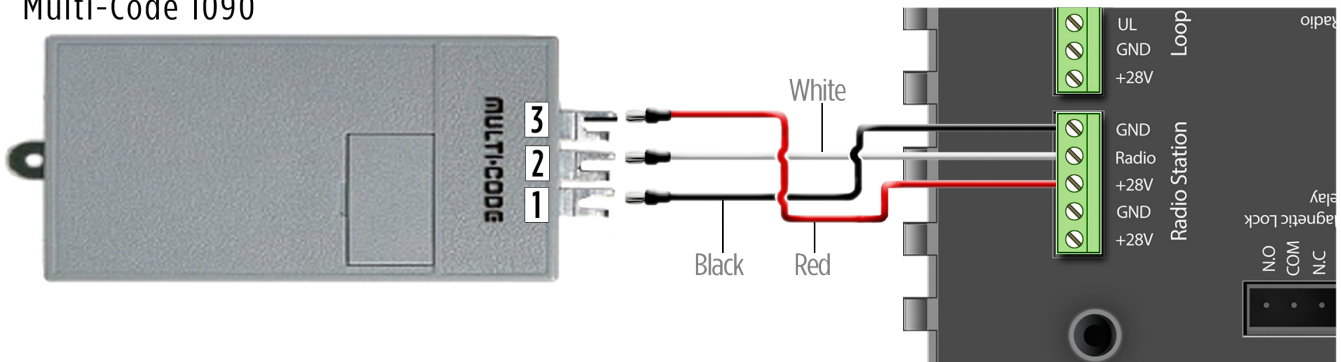

Liftmaster 312HM

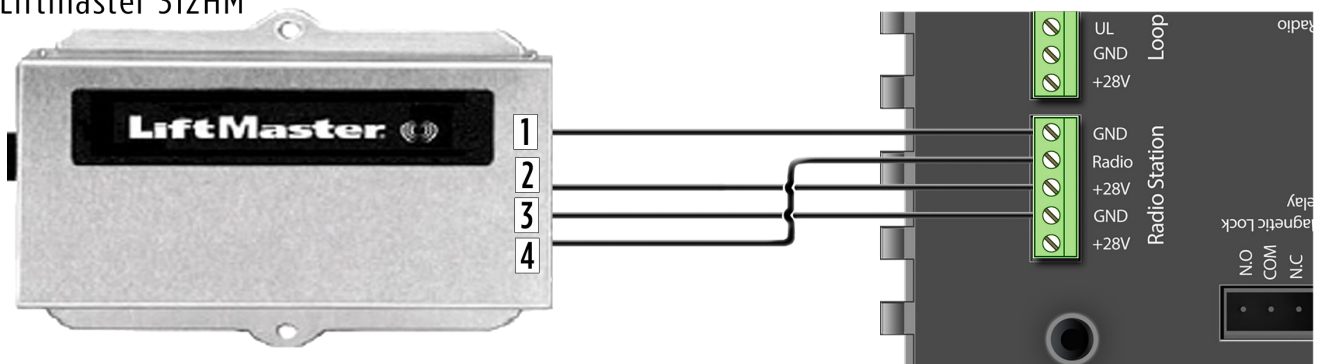

Linear Delta 3 GRD

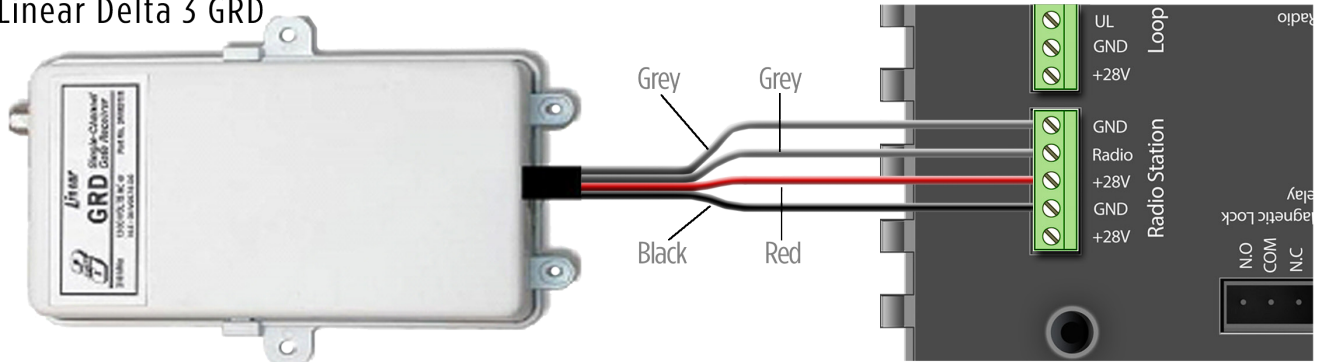

UL ADV Feature

IMPORTANT REQUIREMENTS:

- The installed sensor MUST be “10K Resistor Based”.
- **Only use this feature if** ALL sensors connected to the UL input terminal are desired to reverse the gate all the way to the OPEN LIMIT position.

STEP 1

Connect the Monitored Sensor to the Viking control board input terminals “UL” and “GND” as illustrated.

STEP 2

Turn ON the UL ADV Feature:

- Toggle the “Diagnose” button until you see UL ADV on the LCD Display.
- Default setting is OFF.
- Press and hold the “Stop” button.
- Toggle the “Diagnose” button once.
- The feature should now be displayed as “ON”.

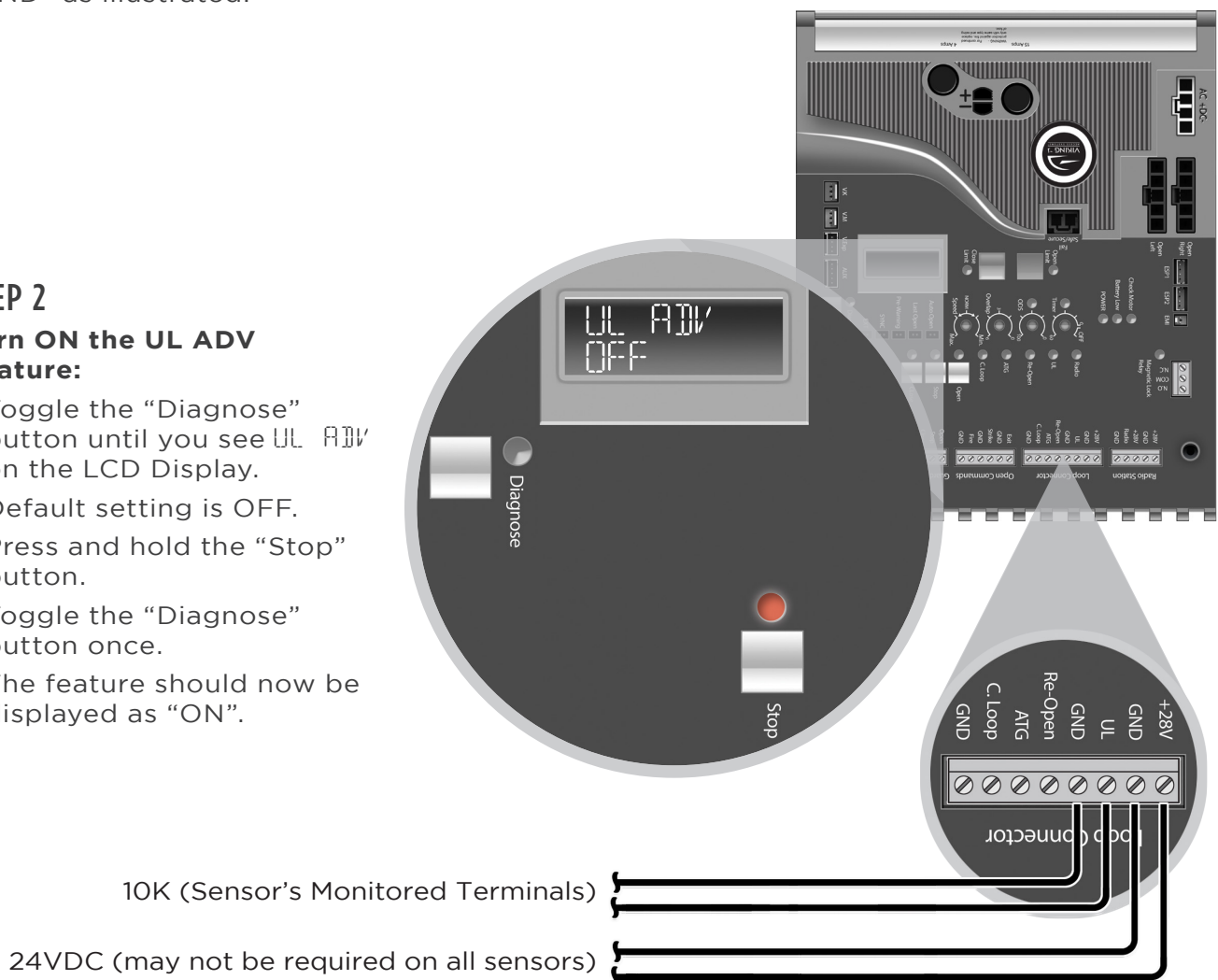

VIKING EXPANSION PRODUCTS



VIKING KONNECT Master/Slave Kit Secure and reliable Master/Slave communication between two single ECU's using Viking's Konnect technology. Paired with the Viking App, the Slave module also doubles as a diagnostic tool.

Part# VA-KONNECT-MS

****Q-7, B-12 & ECU Operators require (2) Antenna Extension Cables (part# VA-RPSMA)****



VIKING KONNECT Diagnostic Tool On-site remote access to the operator from the convenience of a compatible hand held device. With the Viking App, this tool becomes a wireless extension of the control board allowing you to view and change settings, review diagnostic information, operate the gate for testing and update the control boards firmware. **Part# VA-KONNECT-D**

****Q-7, B-12 & ECU Operators require (1) Antenna Extension Cable (part# VA-RPSMA)****



VIKING MONITOR Off-site access to operator diagnostics and perform firmware updates from just about anywhere with cellular service. With the Viking App, this tool allows you to monitor and label multiple operators by site and location for quick reference. Provides error notifications, operator status, settings and diagnostic information.

Part# VA-MONITOR

****Q-7, B-12 & ECU Operators require (1) Antenna Extension Cable (part# VA-RPSMA)****



VIKING APP Mobile device user interface application for Viking Konnect and Viking Monitor. Available for iOS, Android and Windows operating systems. Free for download from your mobile device application store or www.vikingaccess.com



VIKING SOLAR Related Components:

12V 40W Solar Panels Part# VA-S040W

12V 35Ah batteries Part# DUBA35

⚠ NOTE: The number of cycles achieved are dependent upon the following and may require increased panel and battery capacities:

- Power consumption of all accessories being used
- Average solar radiation of geographic location

OUR CONTINUOUS COMMITMENT TO EXCELLENCE

Viking Access Systems is continuously working hard to identify and design products that will appeal to the industry and its needs. As technology continues to advance, we have developed a completely efficient and intelligent line of gate operators to meet the changing demands. These machines offer: full UL325 and UL991 compliance, soft-start and soft-stop, intelligent obstruction sensors and extreme power efficiency. Innovative features include: adaptive and self-learning algorithms, redundancy design in both hardware and software to ensure operation and functionality, protection from lightning, short circuit and power surges, and our exclusive drive-train design offering the highest efficiency rating in the industry. Our entire product line is continually modified and improved based on the latest technology and our customer's valuable feedback. The results are products that offer accuracy, efficiency, reliability and performance, all in sleek, high-tech designs.

We pledge to continue establishing ourselves as the leader in high quality, innovative gate operators by developing "Next Level" technology. We are committed to providing safety and convenience with innovative solutions for every security gate need.



STANDARD FEATURES

- Single 12V battery and single 12V solar panel operation.
- Most Advanced Charging System in the industry.
- Power Saving Technology minimizes current draw.
- Viking Solar Power Management System maximizes the number of cycles per day
- Sleep Mode for non-essential accessories minimizes current draw on stand-by.
- High Efficiency Electromechanical Design increases the number of cycles per day.
- Twice, or more, the number of cycles per day, with a 10W solar panel, compared to other manufacturers.
- Real Time Status Display of the solar panel voltage, charging voltage and battery voltage.
- 4 years limited warranty (Visit our website for more details)
- Built-in protection against lightning strikes or similar electrical surges
- Inherent Overload Protection; Redundancy Design with multiple types of protection.
- Powder Coated Aluminum Enclosure.
- Easy access to manual operation, allowing the gate to be move by hand, independently of the operator.
- Fast and easy installation process.
- Modular connectors for easy access control and accessory installation.
- LCD display for monitoring and diagnostic purposes.
- Self Diagnose Features conveniently displays any errors in the system.
- Made in USA.

INSTALLATION DATE: _____

COMPANY / INSTALLER: _____

CONTACT: _____

SERIAL NUMBER(S): _____

ALL INSTALLATION, MAINTENANCE AND REPAIR WORK MUST BE DOCUMENTED AND MADE AVAILABLE TO THE USER.



VIKING ACCESS SYSTEMS

631 Wald Irvine, CA 92618

Phone 800.908.0884

Fax 949.753.1640

www.vikingaccess.com