

Also available from SECO-LARM:

Twin Photobeam Sensors



- Up to 390ft (120m) range
- Laser-beam alignment
- Weatherproof
- Anti-frost system
- Adjustable response time

Quad Photobeam Detectors



- 4 Models available - up to 660ft (200m) range
- Weatherproof
- 12~24 VAC/VDC
- Laser-beam alignment

Curtain / Barrier Sensors



- 2, 4, 6, 8 or 10 Beams available (10 Beams - curtain sensor only)
- Curtain sensor - Up to 50ft (15m)
- Barrier sensor - Up to 393ft (120m)
- Weatherproof
- Adjustable interruption time

Reflective Photobeam Sensor



- Available with 45ft (14m) or 35ft (11m) range
- Weatherproof
- Mounting hardware included
- Reflector included
- UL325 - 2016 compliant

Hooded Reflective Photobeam Sensor



- Available with 50ft (15m) or 33ft (10m) range
- Weatherproof
- Polarized version available
- Round reflector included
- UL325 - 2016 compliant

Flush-Mount Photobeam Sensors



- Available with reflective beam and 16ft (5m) range or through-beam and 33ft (10m) range
- Adjustable alignment angle
- Mounts to a single-gang box

WARRANTY: This SECO-LARM product is warranted against defects in material and workmanship while used in normal service for a period of one (1) year from the date of sale to the original consumer customer. SECO-LARM's obligation is limited to the repair or replacement of any defective part if the unit is returned, transportation prepaid, to SECO-LARM. This Warranty is void if damage is caused by or attributed to acts of God, physical or electrical misuse or abuse, neglect, repair, or alteration, improper or abnormal usage, or faulty installation, or if for any other reason SECO-LARM determines that such equipment is not operating properly as a result of causes other than defects in material and workmanship. The sole obligation of SECO-LARM, and the purchaser's exclusive remedy, shall be limited to replacement or repair only, at SECO-LARM's option. In no event shall SECO-LARM be liable for any special, collateral, incidental, or consequential personal or property damages of any kind to the purchaser or anyone else.

NOTICE: The information and specifications printed in this manual are current at the time of publication. However, the SECO-LARM policy is one of continual development and improvement. For this reason, SECO-LARM reserves the right to change specifications without notice. SECO-LARM is also not responsible for misprints or typographical errors. Copyright © 2016 SECO-LARM U.S.A., Inc. All rights reserved. This material may not be reproduced or copied, in whole or in part, without the written permission of SECO-LARM.

SECO-LARM® U.S.A., Inc.

16842 Millikan Avenue, Irvine, CA 92606
Tel: 800-662-0800 / 949-261-2999 Fax: 949-261-7326

PITSW3
file:MI_E96x-DxxxGQ_160218.pmd
Website: www.seco-larm.com
E-mail: sales@seco-larm.com



Twin Photobeam Detectors

Manual



Model #	Outdoor Range	Indoor Range
E-960-D90GQ	90 ft. (30m)	190 ft. (60m)
E-960-D190GQ*	190 ft. (60m)	390 ft. (120m)
E-960-D290GQ*	290 ft. (90m)	590 ft. (180m)
E-964-D390GQ*	390 ft. (120m)	790 ft. (240m)

Note: All above models are also available as non-ETL compliant versions.

* Special order only (E-964-D390Q is a multi-frequency version).



TABLE OF CONTENTS

Important	2	Beam Frequency Selection Chart	7
Choosing a Location	3	(E-964-D390GQ Model Only)	
Typical Installations	4	Multiple Sensors Sample Applications	7-8
Running the Cable	4	Adjusting the Alignment	9
Wiring the Transmitter – Wall Mount	4	Testing the Unit	10
Wiring the Transmitter – Pole Mount	5	Specifications	10
Wiring	5	Dimensions	11
Examples of Ways To Connect Sensors	6	Troubleshooting	11
Selectable 4-channel Beam Frequency	7		

Features:

- Four selectable beam frequencies (For E-964-D390GQ model only).
- Twin beams provide reliable perimeter security, minimizing false alarms from falling leaves, birds, etc.
- Lensed optics reinforce beam strength and provide excellent immunity to false alarms due to rain, snow, mist, etc.
- Weatherproof, sunlight-filtering case for indoor and outdoor use.
- Non-polarized power inputs.
- Automatically adjusts beam strength to compensate for different weather conditions
- Automatic input power filtering with special noise rejection circuitry.
- NC/NO trigger output.
- N.C. tamper circuit included.
- Quick, easy installation with built-in laser beam alignment system.

Included:

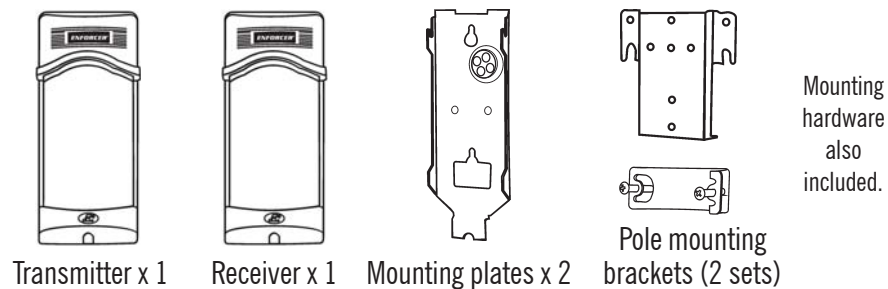

IMPORTANT – Do not connect to power until the sensor is completely installed and the installation has been double-checked.

Fig. 11: Dimensions

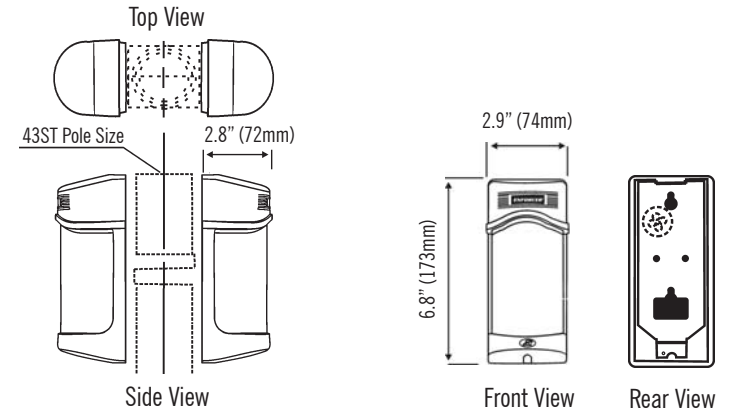

Fig. 12: Beam Spread

The beam spread (s) can be calculated as $s=0.03xd$.

Distance (d)	Beam spread (s)
90ft (30m)	2.7 ft (0.8m)
190 ft (60m)	5.7 ft (1.7m)
290 ft (90m)	8.7 ft (2.7m)
390 ft (120m)	11.7 ft (3.6m)

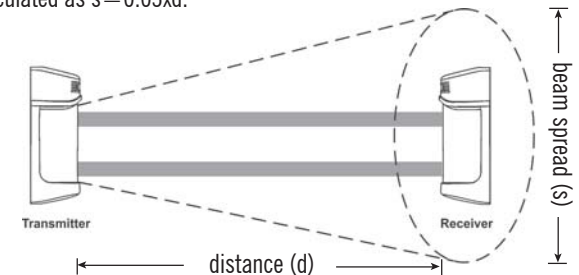

Table 6: Troubleshooting

Situation	Possible Problem	Solution
Transmitter LED does not light.	Incorrectly wired and/or insufficient voltage	Ensure the power supply to the transmitter is 12 to 30V DC/AC, 60Hz.
Receiver LED never lights up when the beam is interrupted.	a. Insufficient voltage b. Beam reflected away from receiver c. Beams not simultaneously interrupted.	a. Double-check the voltage. b. Clean the cover. c. Check overall installation.
Beams interrupted and LED lights, but no trigger output.	Trigger cable may be cut, or the relay contact stuck due to overloading.	Check the continuity of the wiring between the sensor and the alarm.
Trigger LED continuously lit.	a. Lenses out of alignment. b. Beams are blocked. c. Cover is foggy or dirty.	a. Realign the lenses. b. Remove any obstacles. c. Clean the cover.
Trigger becomes erratic in bad weather.	Lenses out of alignment.	Check overall system installation. If still erratic, realign the lenses.
Frequent false triggers from leaves, birds, etc.	a. Too sensitive. b. Bad location.	a. Reduce the response time. b. Change the transmitter and/or location.

Testing the Unit

1. Power up the transmitter and receiver.
2. If the yellow or red LED remains steady ON even when the beam is not interrupted, re-adjust the alignment.
3. Walk between the transmitter and receiver to interrupt the beams. Walk at various speeds, and adjust the delay time adjustment knob as needed.

NOTE – The sensor will be triggered only if both the upper and lower beams are simultaneously interrupted.

IMPORTANT – Test the detector periodically to ensure the alignment settings are suitable for the site.

Table 5: Specifications

Model	E-960-D90GQ	E-960-D190GQ	E-960-D290GQ	E-964-D390GQ
Max. range (outdoor)	90' (30m)	190' (60m)	290' (90m)	390' (120m)
Max. range (indoor)	190' (60m)	390' (120m)	590' (180m)	790' (240m)
No. of beam channel	N/A	N/A	N/A	4
Current draw	50mA max. (laser alignment only)			
	150mA max. (active operation excluding laser alignment)			
Operating voltage	12-30V DC/AC 60Hz, 200mA			
Detection method	Simultaneous breaking of 2 beams			
Interrupt speed	10msec			
Trigger output	SPDT NO/NC/COM relay, 1A@30 VDC/VAC			
Tamper output (Tx & Rx)	N.C. switch, 1A@30 VDC/VAC			
Sensor LED (receiver)	Red LED - ON: When transmitter and receiver are not aligned or when beam is broken			
Signal LED (receiver)	Yellow LED - ON: When receiver's signal is weak or when beam is broken			
Power LED (Tx & Rx)	Green LED ON: Indicates connected to power			
Laser wavelength	650nm			
Laser output power	≤5mW			
Alignment angle	Horizontal: ±90°, Vertical: ±5°			
Operating temperature	-13°F ~ +131°F (-25°C ~ +55°C)			
Weight	2.5-lb (1.1kg)			
Case	PC Resin			

Note: Depending on the monitoring system used by the gate motor, it may be necessary to use either the N.C. output or connect the included 10kΩ resistor to the N.O. or N.C. output. Please refer to the gate operator manual or the gate operator manufacturer for the preferred monitoring method.

Fig. 1: Identifying the Sensors

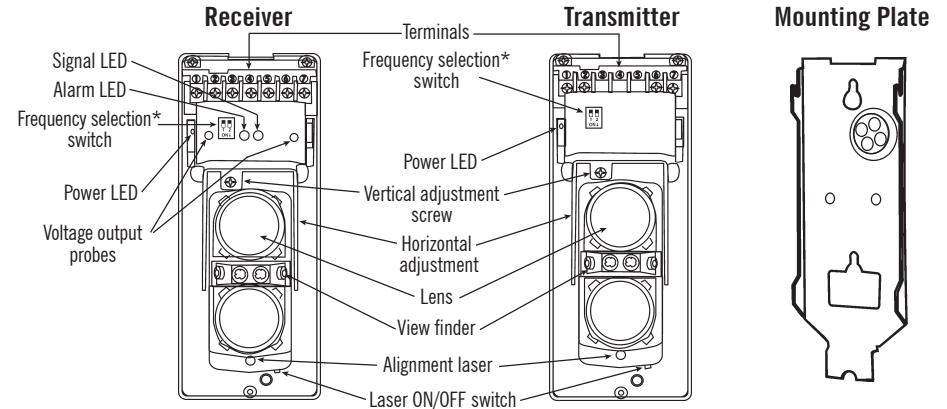

* For multi-frequency E-964-D390GQ model only.

Choose a Location

To prevent erratic operation and/or false alarms:

- Wind will not directly cause false alarms, but could cause leaves or similar objects to fly or wave into the beams. Therefore, do not mount near trees, bushes, or other leafy vegetation.
- Do not mount where the transmitter or receiver could be splashed by water or mud.
- Do not mount where the unit could be suddenly exposed to a bright light, such as a floodlight or a passing automobile's headlight.
- Do not let sunlight or any direct beam of light enter the sensing spot of the transmitter. If needed, mount so the receiver, not the transmitter, faces the sun.
- Do not mount where animals could break the beams.

Fig. 2: Vertical and Horizontal Adjustments

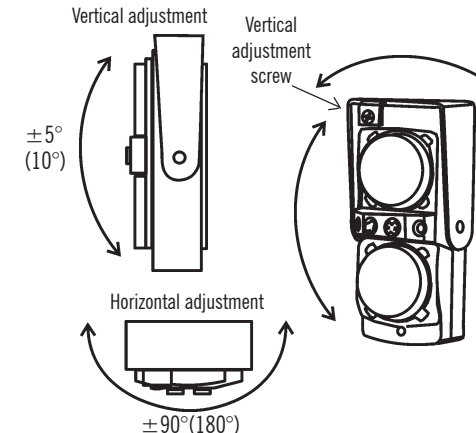
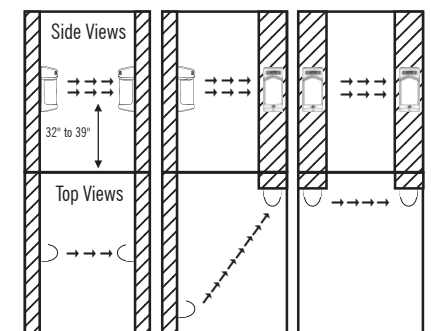

Fig. 3: Typical Installations



Typical Installations

The photoelectric beam lens can be adjusted horizontally $\pm 90^\circ$, and vertically $\pm 5^\circ$ (see fig. 2). This allows much flexibility in terms of how the transmitter and receiver can be mounted. See fig. 3.

Install at a distance of 32" to 39" (80 to 100 cm) above the ground for most situations. See fig. 3.

Running the Cable

Run a cable from the control unit to the photobeam sensor. If burying the cable is required, make sure to use electrical conduit. Shielded cable is strongly suggested. See Table 1 for maximum cable length.

Table 1: Cable Length

Model	E-960-D90GQ		E-960-D190GQ		E-960-D290GQ		E-964-D390GQ	
	12V	24V	12V	24V	12V	24V	12V	24V
AWG22 0.33mm ² 0.0005in ²	320m 1,050 ft.	2,800m 18,000 ft.	280m 920 ft.	2,400m 7,870 ft.	200m 660 ft.	1,600m 5,250 ft.	110m 390 ft.	900m 2,950 ft.
AWG20 0.52mm ² 0.0008in ²	550m 1,800 ft.	4,800m 15,750 ft.	450m 1,480 ft.	4,200m 13,780 ft.	350m 1,150 ft.	3,000m 9,840 ft.	170m 560 ft.	1,400m 4,590 ft.
AWG18 0.83mm ² 0.0013in ²	800m 2,600 ft.	7,200m 23,620 ft.	700m 2,300 ft.	6,200m 20,340 ft.	500m 1,640 ft.	4,200m 13,780 ft.	250m 820 ft.	2,200m 7,220 ft.
AWG17 1.03mm ² 0.0016in ²	980m 3,190 ft.	8,800m 28,870 ft.	850m 2,790 ft.	7,600m 24,930 ft.	590m 1,940 ft.	5,200m 17,060 ft.	310m 1,020 ft.	2,600m 8,530 ft.

Note (1): Max. cable length when two or more sets are connected is the value shown in Table 1 divided by the number of sets.

Note (2): The power line can be wired to a distance of up to 3,300 ft. (1,000m) with AWG22 (0.33mm²) telephone wire.

Wiring the Transmitter – Wall Mount

1. Remove the cover. Remove the screw under the lens unit in order to detach the mounting plate. See fig. 4.
2. If the sensor wiring comes from inside the wall – Break a hole in the mounting plate's rubber grommet, and pull the cable through the grommet's hole. Then run the cable through the hole near the top of the sensor unit so it comes out the front. Using two of the included mounting screws, attach the mounting plate to the wall. Then reattach the sensor unit to the mounting plate, connect the wires, and snap on the cover. See fig. 5.
3. If the sensor wiring is run along the surface of the wall – There are two plastic knockouts on the back of the sensor unit, one on top and one on bottom. Break out the appropriate knockout, and pull the wiring through the knockout. Then run the wiring through the hole near the top of the sensor unit so it comes out the front. Using two of the included mounting screws, attach the mounting plate to the wall. Then reattach the sensor unit to the mounting plate, connect the wires, and snap on the cover. See fig. 6.

Adjusting the Alignment

The transmitter and receiver sensor units can be adjusted $\pm 5^\circ$ vertically and $\pm 90^\circ$ horizontally once the unit is mounted and power is connected (see fig. 2 on page 3).

There are two ways to adjust alignment:

1. Laser adjustment (see fig. 1 on page 3):
 - a. Remove the transmitter cover, then turn the laser on with the ON/OFF switch (see fig. 1 on page 3). A red dot will show where the photoelectric beams are aimed.
 - b. Adjust the transmitter's sensor unit vertically and horizontally until the red dot is centered on the receiver and both the receiver's LEDs turn off. See Table 3. It may be necessary to adjust the horizontal and vertical angles of the receiver's sensor unit as well.
 - c. Repeat steps a and b for the receiver.
 - d. Turn the lasers off, and then replace the covers.

WARNING: Do not look directly at the lasers.

2. Eyeball adjustment (see fig.10):
 - a. Remove the transmitter cover, and look into one of the alignment viewfinders (one of the four holes located between the two lenses) at a 45° angle.
 - b. Adjust the horizontal angle of the lens vertically and horizontally until the receiver is clearly seen in the viewfinder.
 - c. Repeat steps a and b for the receiver.
 - d. Replace the transmitter and receiver covers.

NOTE - If you cannot see the opposite unit in the viewfinder, put a sheet of white paper near the unit to be seen, move your eyes about 2" (5cm) away from the viewfinder, and try again.

Fine Tuning the Receiver

1. Once the sensor is mounted and aligned, the sensor can be fine tuned using the voltage output jack.
 - a. Set the range of a volt-ohm meter (VOM) to 1~5VDC.
 - b. Insert the red (+) probe into the (+) terminal and the black (-) probe into the (-) terminal.
 - c. Measure the voltage (see table 4).
 - d. Adjust the horizontal angle by hand until the VOM indicates the highest voltage.
 - e. Adjust the vertical angle by turning the vertical adjustment screw until the VOM indicates the highest voltage.

NOTE: Do not interrupt the beam while adjusting alignment.

Fig. 10:
Horizontal and Vertical Sensor Adjustment

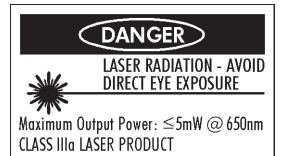
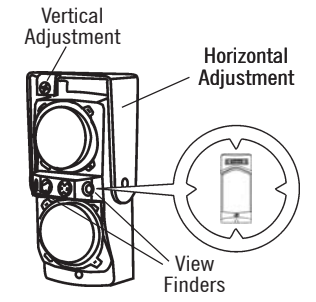

Table 3: Receiver LED Indicators

Alarm (Red LED)	Signal (Yellow LED)		Signal strength
	Single frequency	Multi frequency	
OFF	OFF	OFF	Best
OFF	OFF	Flash	Good
OFF	ON	ON	Fair
ON	ON	ON	Re-adjust

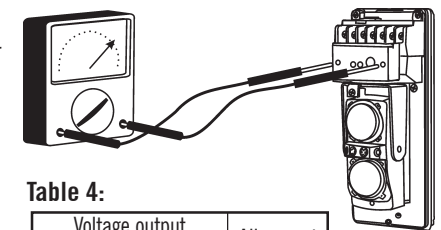
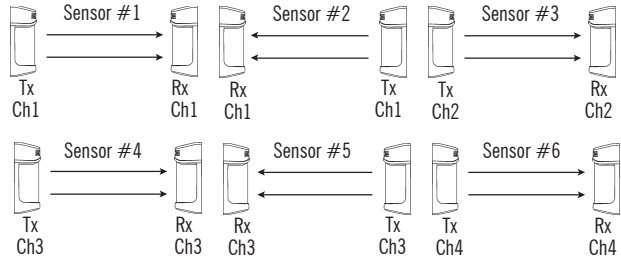

Table 4:

Voltage output		Alignment quality
Single frequency	Multi frequency	
>2.8V	>2.8V	Best
1.7~2.7V	1.8~2.7V	Good
1.1~1.6V	1.1~1.7V	Fair
<1.0V	<1.0V	Re-adjust

3. Two layer (double stacked) applications.



4. Perimeter security application.

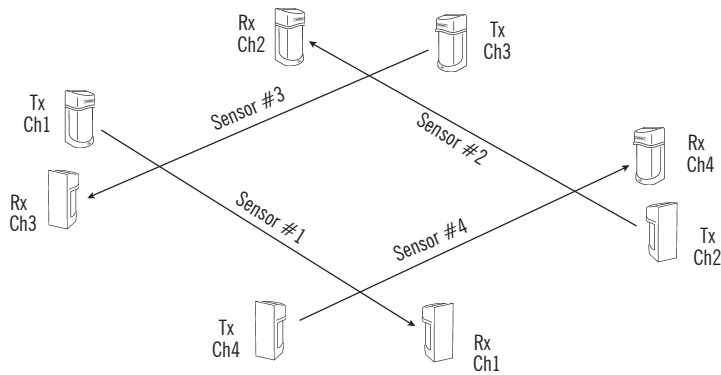

5. Two layer (double stacked) perimeter security application.

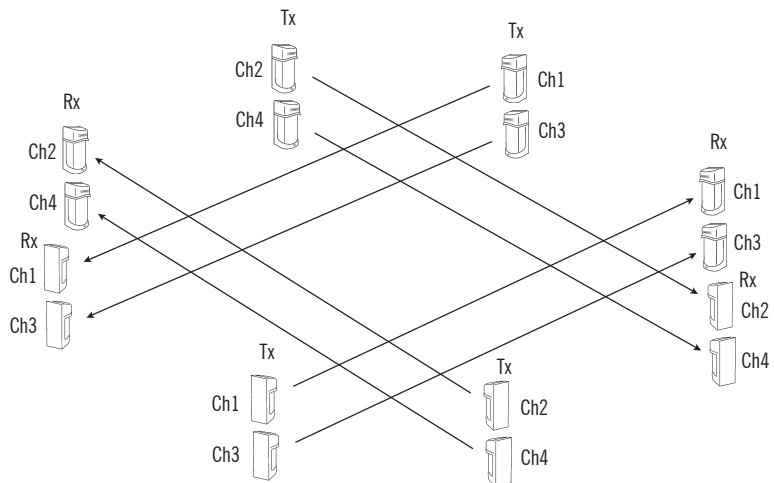

Wiring the Transmitter – Pole Mount

(NOTE – Pole mounting bracket required.)

1. Remove the cover. Remove the screw under the lens unit in order to detach the mounting plate. See fig. 4.
2. Break a hole in the mounting plate's rubber grommet, and pull the cable through the grommet's hole. Then run the cable through the hole near the top of the sensor unit so it comes out the front. Use the included mounting bracket to mount to the pole. Then

reattach the sensor unit to the mounting plate, connect the wires, and snap on the cover. See fig. 7.

Wiring (fig. 8)

1. Screw the wires tightly to avoid slipping off the terminals, but not so tight that they break.
2. Screws on terminals which are not used should be tightened.
3. Grounding may be necessary, depending on the location.

Fig. 4: Remove the Transmitter cover

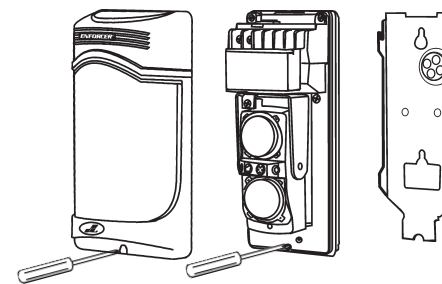

Fig. 5: Wall Mount, Wire from Inside Wall

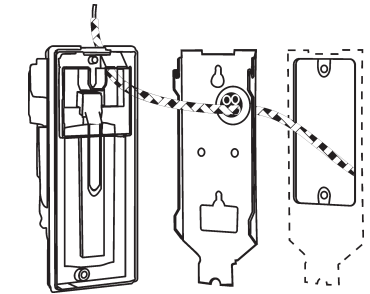

Fig. 6: Wall Mount, Wire Runs Along Wall

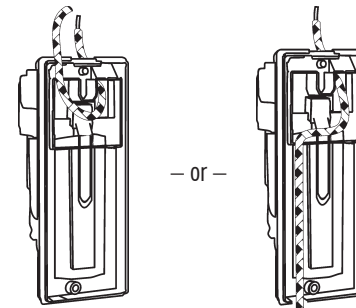

Fig. 7: Pole Mount

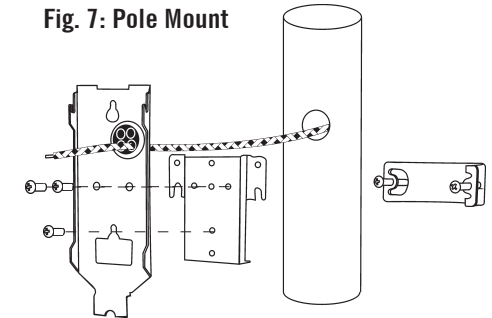

Fig. 8: Wiring

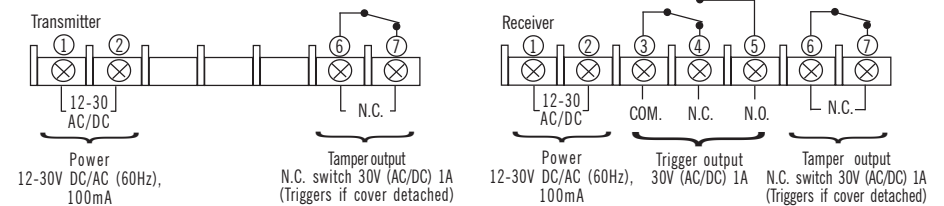
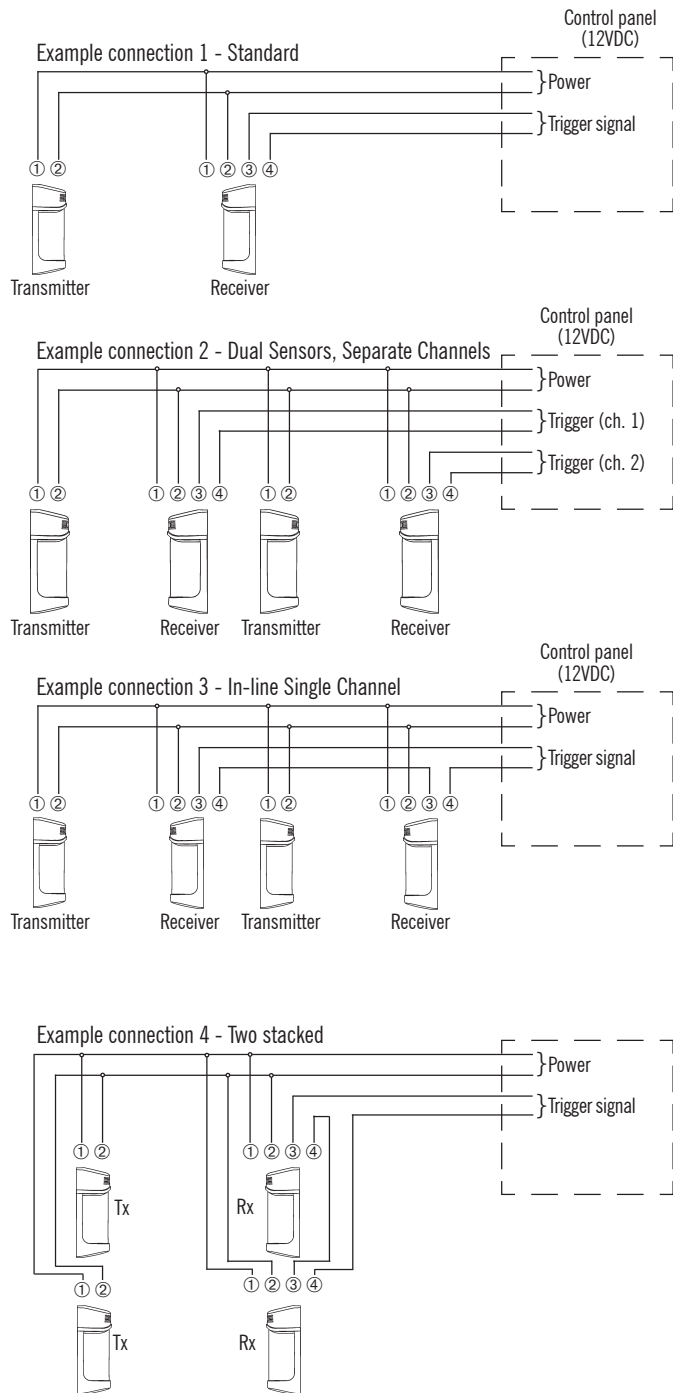

Fig. 9: Examples of Possible Ways To Connect One or More Sensors



Selectable 4-channel beam frequency (For E-964-D390GQ model only)

The sensor beam frequency can be set at different levels on-site to avoid interference from other twin photobeam sensors nearby. Useful during multiple sensor applications as shown below. To select between four different beam frequencies, adjust the beam channel switch of the transmitter side and receiver side. See fig. 1 for switch location and table 2 for switch position.

Important – The transmitter and receiver sensor pair must be set with the same frequency.

Table 2: Beam Frequency Selection Chart (For E-964-D390GQ model only)

Frequency channel	CH1	CH2	CH3	CH4
Switch position				

Multiple sensor sample applications (For E-964-D390GQ model only)

1. Single pair multiple layer application.

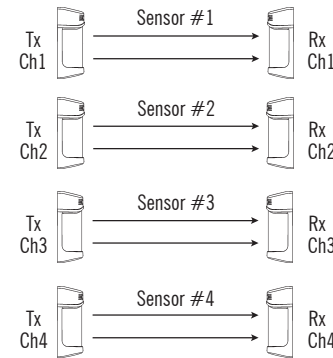

2. Long distance series application.

