

TIGERGRIP | DS-Grab 5 - 6

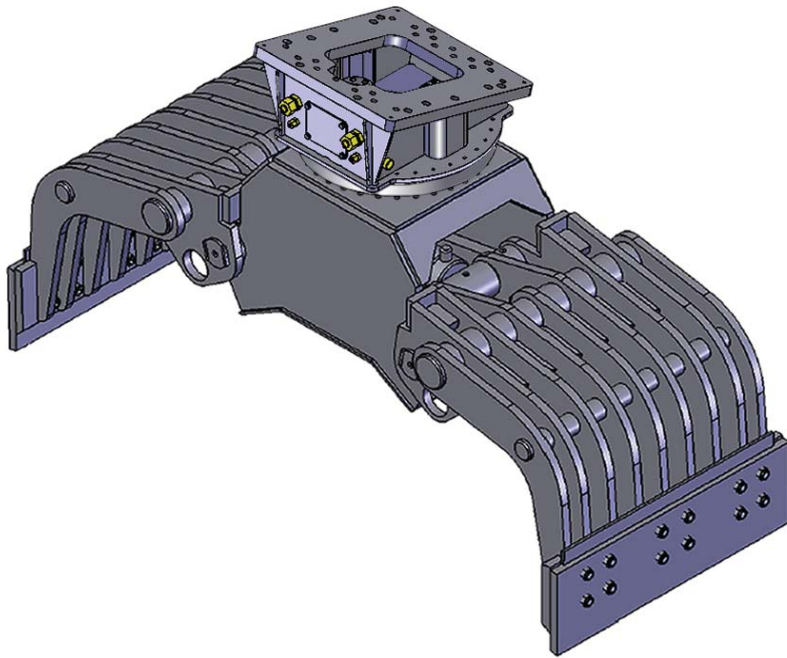

KEY FEATURES

- Heavy duty
- Double guide bars
- High pressure cylinder with double piston rod seals
- High tensile wear resistant steel (400 HB)
- Extra reinforced body for rigid mounting - Excavator design
- Self lubricating bushings
- Reversible cutting edges
- High tensile wear resistant steel cutting edges (500 HB)
- Pilot operated check valve

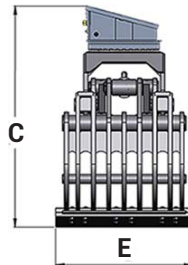
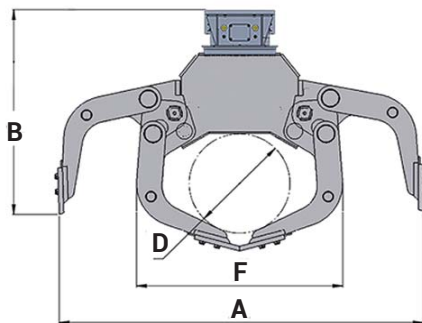

	DS-Grab 5	DS-Grab 6
A	1936	2347
B	1283	1447
C	1485	1687
D	530	650
E	800	1000
F	1085	1330

MODEL SPECIFICATIONS



Model	Kg	m ²	Bar	l/min	kN	ton
DS-Grab 5	1225	0,35	350	60/30	57	18-22
DS Grab 6	1770	0,50	350	90/30	69	20-25

INTERMERCATO

High performance lift and load attachments for Forestry, Transport, Construction and Recycling.

