

ST11

Compact Track Loader



**WACKER
NEUSON**
all it takes!



Versatility is the real driver of this machine

The versatile ST11 Compact Track Loader is an excellent addition to any hire or contractor fleet and is the perfect fit for landscaping projects, light site work, grading, auguring, general material handling and much more!

- Diesel engine Turbo Kubota V 1505 T, 4 cylinders, 1498 cm³.
- Two speed with a maximum speed of 10 Km/h.
- “High Flow” option to operate high demand attachments.
- Idle wheels with taper roller bearings giving high carrying capacity.
- ROPS FOPS 1st stage - open cab - Power Take Off (P.T.O.) with quick couplings - Floating valve to equalize the bucket to ground level – Universal quick hitch. Front working lights. Reverse motion alarm. Suspension seat, foot and hand throttle, flip up cab for ease of maintenance access.

ST11 Technical specifications

Rated Operating Capacity @35%/50%	400/520 kg
Break-out force	930 daN
Operating weight	2,220 kg
Travel speed I / II	4.5 / 10 Km/h
Operating pressure - ground	180 bar
Lifting force (from ground)	1030 daN
Auxiliary Flow (std/hf)	39/70 l/min
Engine / Motor	Kubota Diesel Engine V1505T
Power	41 hp
Fuel tank capacity	42 litres

ST11 Dimensions

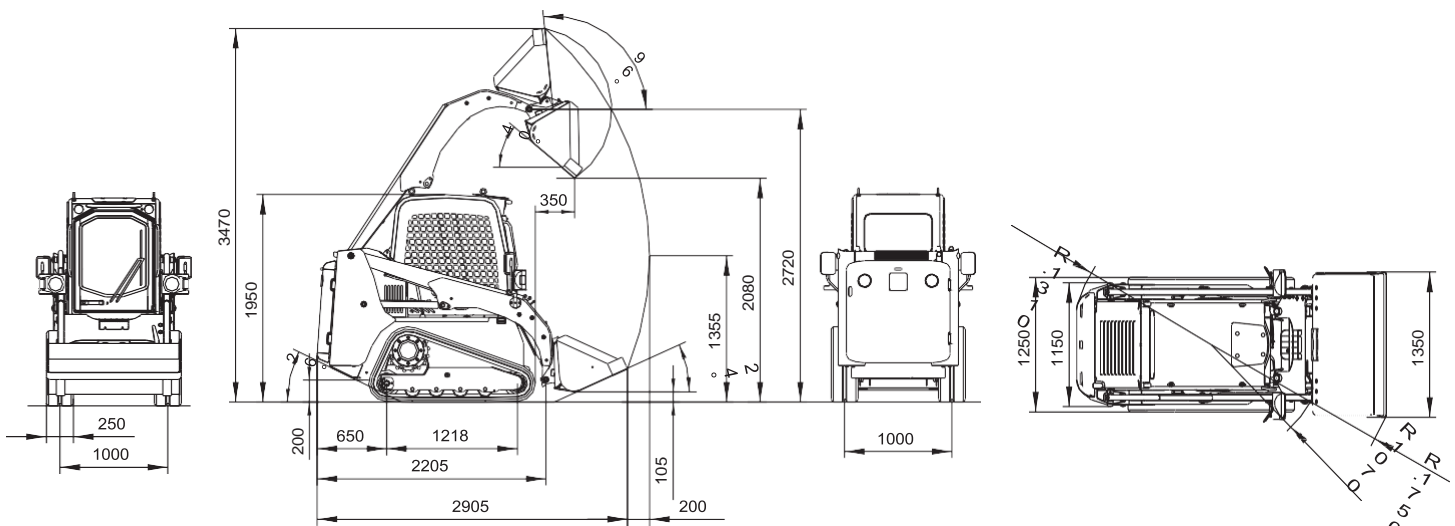

Dimensions in mm

Data, features and pictures are not binding and may be altered without any prior notice.

Please note: that product availability can vary from country to country. It is possible that information / products may not be available in your country. More detailed information on engine power can be found in the operator's manual; the stated power may vary due to specific operating conditions. Subject to alterations and errors excepted. Applicable also to illustrations.

Copyright © 2022 Wacker Neuson SE.