

# SATELLITE 480 (SP) Generation3

## SAFETY & OPERATORS MANUAL & PARTS LISTING

CAUTION: Read the instruction manual before using the appliance.



DESIGNED & BUILT IN AUSTRALIA

Satellite 480 G3 Manual

V210514

## **Contents**

Specifications.....	2
Safety instructions .....	3
Safety instructions .....	4
Operating Instructions.....	5
Operating Instructions.....	6
Handle Positions .....	7
Tooling position & Magnetic plugs .....	8
Axle height adjustment.....	8
Display Functions .....	11
Electrical safety.....	12
Problem solving .....	13
Diamonds .....	14
Diamonds .....	15
Wiring Diagram.....	16
Main Machine Breakdown .....	17
Handle Breakdown .....	18
Disk Breakdown .....	19
Handle Lock Breakdown .....	20
Motor Breakdown.....	21
Axle Breakdown .....	22
Screen Breakdown .....	23
Shroud Breakdown.....	23
SP Plug Breakdown (for SP machines only).....	25
SP Drive Boss Breakdown (for SP machines only).....	26
SP Shrouds Breakdown (for SP machines only) .....	27
Warranty .....	28

Specifications

Satellite 480 Generation3	
Weight	160kg (182kg including weights)
Head Pressure	112kg (134kg with weights on head)
Dimensions	543 x 1007 x 1447 (Width x Height x Length)
Rated Voltage	230 Volt 50 Hz
Rated Watts	2200W
Grinding Path	480mm

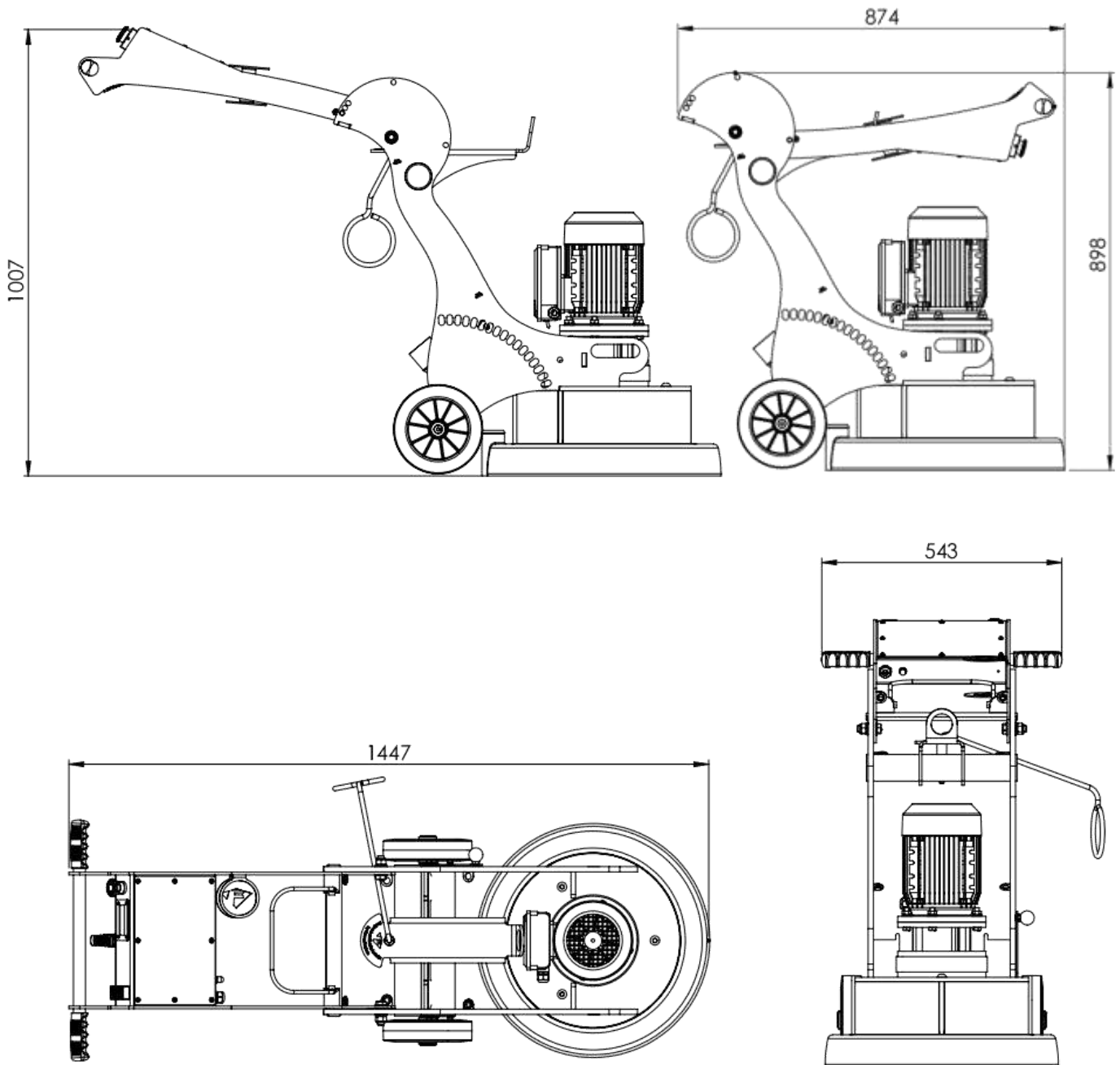

### Safety instructions

1. Read and understand the instructions on the machine and in this manual and engine manual (if applicable). Different models may have different parts and controls.
2. Equipment should only be operated by trained personnel, in good physical condition and mental health (not fatigued). The operator and maintenance personnel must physically be able to handle the bulk weight and power of this machine.
3. The SATELLITE 480 Generation3 must only be used according to the instructions given in this manual. Any other work methods or practices could result in injury or death
4. The SATELLITE 480 Generation3 has different positions in which the handle can be locked into. These are described in this manual as 'OPERATE', 'TOOLING POSITION' and LIFT/STORAGE'. See Handle Positions for diagrams of these positions. When to use and when not to use these positions is described throughout this manual
5. This is a one person machine. Maintain a safe operating distance to other personnel. Remember 'one machine, one operator'.
6. This equipment is intended for commercial use.
7. For the operators' safety and the safety of others, always keep all guards and shrouds in place.
8. The weights are there to assist the machine in operation. Always remove them from the handle before folding it to the tooling mode or storage mode
9. Never start or run machine when it is unattended.
10. Check for wear on magnetic plugs every 3 hours of use
11. This machine is only intended for use on floor surfaces such as concrete, terrazzo and other hard floor surfaces.
12. The handle height is adjustable with different positions for operator comfort. These positions are shown next to the locking mechanism as 'OPERATE'. The SATELLITE 480 must never be started or used with the handle in any other position other than the 'OPERATE' positions'
13. Never attempt to adjust the handle position when the machine is in operation.
14. Never start or run machine with the handle folded or when disk(s) are not in contact with the surface.
15. Do not lend or rent machine without the operating and safety instructions for the machine (and the engine, if applicable).
16. Wear clothing suitable for the job and for the work place including, safety shoes, hard hat, hearing protection, non-fogging vented safety goggles, and dust mask suitable for dust.
17. Keep body parts or any loose clothing away from moving parts. Failure to comply could result in bodily injury.

**Safety instructions**

18. Do not modify machine in any way. Only use genuine SATELLITE parts and accessories.
19. Repairs should be performed by qualified persons only.
20. Ensure parts have stopped moving and disconnect power or spark plug when servicing or changing blades or accessories.
21. Never operate machine in rain or if heavy moisture is present.
22. Petrol is extremely flammable and poisonous. Petrol should only be dispensed in well ventilated areas, and only when engine is cool.
23. **WARNING! POISONOUS EXHAUST GASES.** Do not operate petrol powered equipment, including generators, without adequate ventilation. Carbon monoxide is an invisible odourless gas that can harm or can kill.
24. Do not operate SATELLITE 480 with any covers or doors removed or open.
25. The SATELLITE 480 can produce sound pressure levels greater than 85db. The operator must wear approved safety ear protection.
26. Do not allow the supply cord to come in contact with the cutting blade/head or other moving parts of this machine.

### Operating Instructions

27. Wear clothes suitable for the job and for the work place including, safety shoes, hard hat, hearing protection, non-fogging vented safety goggles, and dust respirator suitable for dust.
28. The SATELLITE 480 Generation3 must only be used according to the instructions given in this manual. Any other work methods or practices could result in injury or death
29. WARNING! Disconnect power before moving the Handle to the 'TOOLING POSITION' or 'LIFT' positions.
30. WARNING! POISONOUS EXHAUST GASES. Do not operate petrol powered equipment, including generators, without adequate ventilation. Carbon monoxide is an invisible odourless gas that can harm or can kill.
31. Be sure all equipment is tested and tagged prior to use on any job.
32. Inspect entire area to be ground before grinding and remove any bolts or concrete nails (etc) that could damage tooling or the machine and which could cause a hazardous situation.
33. Ensure there are no obstacles or existing structures that could present a hazard to the operator. If so, take necessary action to eliminate the hazard.
34. Fold handle to the 'TOOLING' position and ensure it is locked in place, then tilt machine back so handle is resting along the floor.
35. The machine takes a set of three (3) tools. Be sure the tools are of even height.
36. Install appropriate diamond tooling or other available tooling into the machine. Only use genuine SATELLITE tooling. Failure to comply could result in bodily injury. See section 'TOOLING POSITION' for illustrations on how to remove and install tooling
37. Tilt machine back onto the disk and put the handle in one of the 'OPERATE' positions. Adjust the position to one that you are comfortable with.
38. Never attempt to adjust the handle position when the machine is in operation.
39. Connect machine to suitable power outlet. Only use heavy duty power lead suitable for high current use (preferably 2.5mm<sup>2</sup> cable), no longer than 15 meters.
40. If no power is available within the specified distance, have a qualified person install a suitable power outlet closer to your work. Alternatively use 4mm<sup>2</sup> cable for up to 40 meters.
41. Connect a suitable dust extractor to the machine via a 38 or 50mm flexible hose. The machine is designed to take the standard 50mm hose ends to make connection of dust extractors easy and hassle free.
42. Keep machine clear of drainage pits, grates, steps or major lips or such hazard. Failure to comply could result in bodily injury and or could damage the machine or property.
43. Ensure machine is on a level surface and handle is in one of the 'OPERATE' positions
44. This machine is designed to operate with the wheels in contact with the floor at all times. Do not operate with wheels off the floor.

### Operating Instructions

45. The SATELLITE 480 Generation3 has axle height adjustment to make it easy to adjust the machine so it doesn't cause fatigue on the operator. To set axle height, adjust the axle height lever to the vertical position, or midpoint. This is a good starting point. After initial operation the axle can be adjusted. The axle lever must be set as far back (toward operator) as possible without creating excess force on the operator during operation.
46. Switch on the dust extractor.
47. Hold the handles firmly and switch the SATELLITE 480 Generation3 on by pushing the green button.
48. The controls on the SAT480 Generation3 include an over load device. It is there to protect the controls and motor from irreparable damage. If it trips it indicates a problem. (i.e.; undersize power lead or poor power to your power supply). Refer earlier in this section for recommendations on power leads. Rectify the problem or decrease load on the Satellite 480 by using tooling with more surface area, or place weights supplied on the brackets on handle for this purpose.
49. Continuing to use the SATELLITE 480 when constant tripping occurs, VOIDS THE WARRANTY.
50. Do not attempt to make any adjustments while the machine is in operation. Any adjustments must only be performed when machine is stopped and power disconnected.
51. In the event of the machine pulling to one side all the time; adjust the axle height to obtain the best result. (See 'AXLE HEIGHT'). This machine is designed to operate with the wheels in contact with the floor at all times. Do not operate with wheels off the floor.
52. After a few minutes of grinding check the wear of the diamond tooling. This will pay handsomely if the diamonds are wearing out fast due to soft concrete / abrasive concrete. There is a wide range of diamonds available to suit every need. See Section 'DIAMOND TOOLING SELECTION GUIDE'.
53. Check for wear on magnetic plugs every 3 hours of use
54. See Section 'PROBLEM SOLVING' for tips on how to grind faster on tough concrete and how other problems can be rectified.
55. **WARNING!** As with any diamond tooling, breathable silica may be generated by use and maintenance of this machine. Silica can cause severe and permanent lung damage, cancer, and or other serious diseases. Do not breathe the dust. Do not rely on your sight or smell to determine if dust is in the air. Silica may be in the air without a visible dust cloud. If air monitoring for silica is not provided by your employer at your work site, you must wear appropriate respiratory protection when operating or maintaining this equipment. Consult your employer for proper respiratory protection.

### Handle Positions

56. The handle on this machine can be locked in different positions for different purposes. These positions must only be used for the purpose intended as outlined in this manual. . Failure to comply could result in bodily injury.

57. These positions are shown below and when and where to use them is outlined throughout this manual.

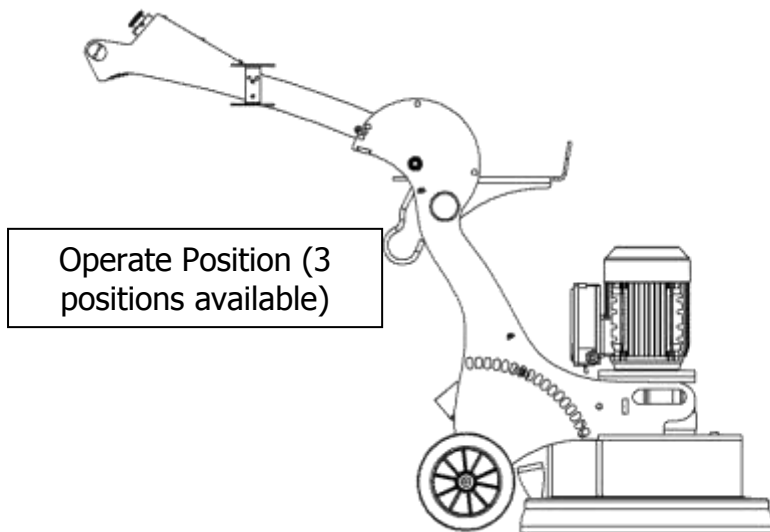

Lift / Storage Position

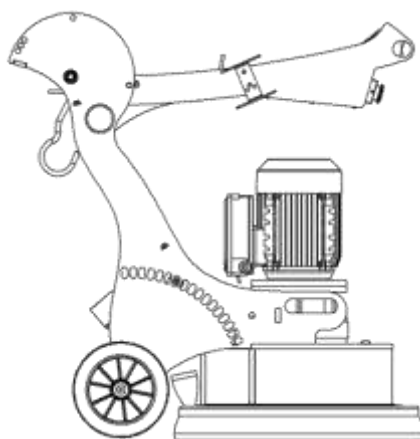

Tooling Position

Tilt Onto Back

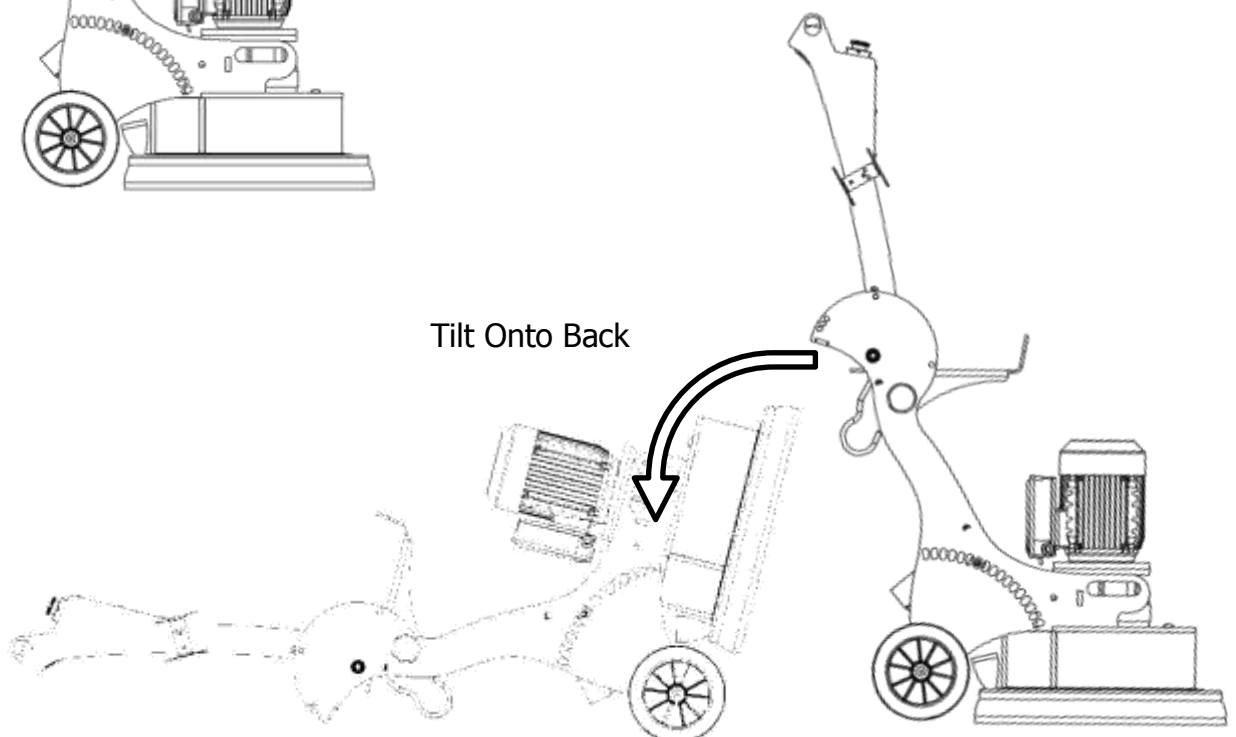



Tooling position & Magnetic plugs

- 58. It is very important to remove all plugs from the unit before installing standard Diamond Plugs. This includes Magnetic and for the SP machines, the SP Drive System.
- 59. To remove tooling from the magnetic plugs, Tilt the machine to the tooling position as per instructions in the operating instructions and grasp hold of the diamond disk and give it a sharp pull away from the main black disk.
- 60. To remove the plug from the main black disk strike the black disk beside the taper insert as shown below.



- 61.
- 62. The magnetic plugs must be cleaned from dust and other debris every time you change satellite disks. The insert should go in all the way up into the plug up to the step on the insert.
- 63. If the insert is getting signs of wear on the top it is because the insert hole has debris in it or hard packed dust against the magnet.



- 64.
- 65. Clean out the hole in the plug where the insert goes. Ensure there are no particles or pieces of steel (such as staples ETC). The hole where the insert goes in the plug can be cleaned with a screwdriver to remove packed dust etc.

**Magnetic plugs**

66. Ensure the insert is not worn to less than 20mm diameter where the blade runs on the insert. This is equivalent to the diameter of the section above it.



67.

68. Put the insert through the satellite disk and install the two parts onto the plug ensuring the insert goes completely into the plug.

**SP plugs**

69. The SP versions of the Satellite machines don't have magnetic plugs supplied. The SP versions have the SP plug with a disc retaining rubber ring that retains the diamond tooling onto the machine.

70. Magnetic Plugs can be used but the SP plugs must be removed before to prevent damage to the unit.

71. The disc retaining rubber ring must be checked for wear or splitting before each operation to ensure the safety of the machine is not compromised.

72. The SP Machines must be used with original manufacturer's diamond tooling with the drive holes to assure safe operation. Using aftermarket tooling could void the warranty on the machine and could cause an unsafe operation.

73. To remove the diamonds on the SP machines simply pull the tag on the disc retaining rubber ring. To reinstall the tooling fit the disc and then work the ring over the face of the plug and into the groove making sure the ring is bedded correctly in the groove.

Disc retaining rubber ring

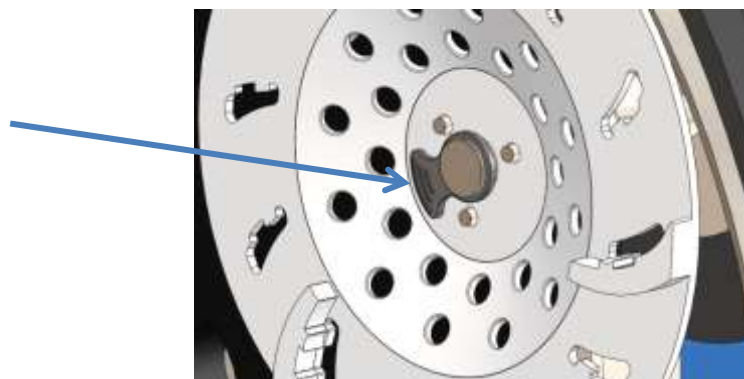

### Axle height adjustment

74. This machine is designed to operate with the wheels in contact with the floor at all times. Do not operate with wheels off the floor.
75. There is a level bubble provided (located behind the motor) for levelling the machine for best user experience and coupling life. It does not change the grinding results in any way.
76. The axle lever should be set so the bubble is up to the forward line on the spirit level. This assures the longevity of the coupling life and gives the nicest position for ease of use. (Assuming the floor is level)

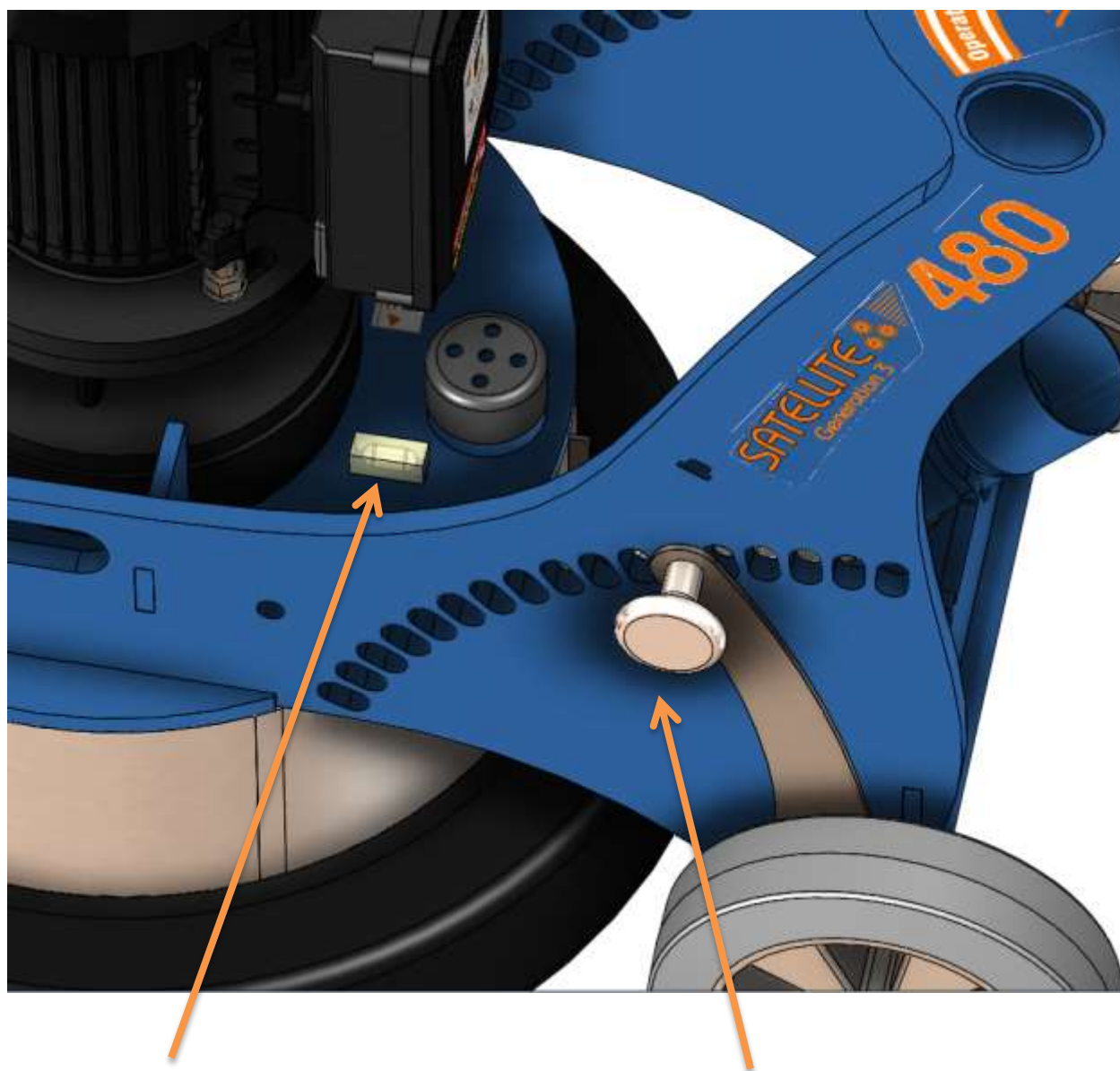

Level Bubble

Axle Lever

Display Functions

- 77. The Generation3 Grinders feature a display screen with a backlight. This is a new feature that greatly enhances the user experience in that the operator knows what the machine is doing, taking a lot of the guess work out of the job.
- 78. There are 3 things the meter measures.
  - a. Voltage
  - b. Amps Draw
  - c. Hours Run
- 79. When you first plug the machine in, the display will be similar to the "READY" screen below.

READY Screen



- 80. This Screen shows the voltage of the supply and also the hours that machine has been running for.
- 81. When you start to use the machine the "RUNNING" display will show. This screen shows the Voltage and the amps while the machine is in operation. The bottom line shows the LOAD as a percentage of motor power available. Running the machine over 100% for extended periods will result in the overload tripping to protect the machine.

RUNNING Screen



- 82. With the HVA meter on the satellite it is now possible to check a lot of the things your electrician will check if there are power issues. Common problems that can be identified are;
  - a. Voltage drop when under load due too long or under size extension leads. This often causes the Amps to increase in proportion to the voltage loss.
  - b. High amps when voltage is still within 10% of normal. Caused by high load jobs like aggressive diamonds or when polishing.
- 83. Hours run is only counted when machine is being used (over 0.5 Amps) and counted with accuracy of two decimal places
  - a. The first decimal place is a 10<sup>th</sup> of an hour being 6 minutes
  - b. The second decimal place is a 10<sup>th</sup> of 6 minutes being 36 seconds.

### Electrical safety

84. All electrical maintenance and repairs are to be carried out by qualified persons only.
85. CAUTION - Line terminals may be alive when main switch is in the off position. Disconnect the machine completely before performing any maintenance or repairs.
86. WARNING - DO NOT operate the machine with any electrical panels open.
87. WARNING - The controls on the SAT480 Generation3 include an over load device. It is there to protect the controls and motor from irreparable damage. If it trips it indicates a problem. (i.e.; undersize power lead or poor power to your power supply). Refer earlier in this manual for recommendations on power leads. Rectify the problem or decrease load on the Satellite 480 by using tooling with more surface area, or place weights supplied on the brackets on handle for this purpose.
88. Continuing to use the SATELLITE 480 when constant tripping occurs, VOIDS THE WARRANTY!
89. Never operate machine in the rain or if heavy moisture is present.
90. The overload is there to protect you and the machine from harm. DO NOT bypass or adjust the over load in any way. If it is faulty, only replace with original part that is identical to the faulty one.
91. Never bypass over current devices in this machine.
92. Never connect or disconnect power cables with voltage present or while under load.
93. Disconnect all power connections and observe lock out / tag out procedures before attempting to carry out any maintenance or repair on any equipment.
94. Avoid any contact with any rotating parts or driven parts.
95. Never use equipment that has not been tested and tagged (including cords).
96. Before connecting the machine to power, check the condition of all power leads and cables on, or used in conjunction with the machine. DO NOT USE it if any faults, cuts, wear marks, etc... Get qualified persons to repair and re-tag it as required by regulations in your country.
97. Connect machine to suitable power outlet. Only use heavy duty power lead suitable for high current use (preferably 2.5 mm<sup>2</sup> cable), no longer than 15 meters.
98. If no power is available within the specified distance have a qualified person install a suitable power outlet closer to your work. Alternatively use 4 mm<sup>2</sup> cable for up to 40 meters.
99. Do not operate SATELLITE 480 with any covers or doors removed or open.

**Problem solving**

101. Diamond Grinding has many variables. When you understand some of these, you can solve a lot of problems without a lot of bother and expense.

PROBLEM	CAUSE	REMEDY	EXPLANATION
Machine will not start / run.	No power is present at cable end.	Check the power is present with another tool.	Using another tool confirms power is present
	Machine is trying to start on glue or other sticky substance.	Clear a patch with a scraper and grind into the glue a little at a time.	This means it only tackles a small amount of glue at a time and keeps the glue residue coated with dust, preventing glue sticking and building up on the diamonds.
	Power lead is too small in capacity or too long.	Upgrade the power lead to 2.5mm <sup>2</sup> (15meters max) or 4mm <sup>2</sup> (40 meters max).	The long / small capacity cable is too restrictive and can't allow enough power through for the machine to start / run properly.
		Use weight on the handle.	The weight on the handle reduces the load on the machine thus reducing the current.
Machine is not grinding at all.	No blades / accessories in unit.	Fit blades. <b>Note; check wear on machine.</b>	
	Very hard concrete or glazed topping on concrete.	Turn dust extractor down / restrict flow. Only just control the dust from escaping.	The extra dust accumulating on the floor acts as an abrasive between the segments and the floor thus exposing the diamonds better.
		Place river sand or cement on the floor.	The sand is an abrasive as described above.
		Use softer grade of diamond tooling.	The softer grade will expose the diamonds better.
		Use coarser diamond tooling.	The coarser diamond tooling can get through hard toppings without wearing out the diamonds too fast.
		Reverse the rotation of the machine (switch on the bottom of the motor box)	The tooling exposes the diamonds when reversed. This works best when using plugs.
The diamonds are wearing out too fast.	The concrete is: *Soft *Abrasive *Rain Damaged *A rough finish (Scarified or shot blasted).	Use a powerful dust extractor to remove as much dust as possible.	The dust, as described acts as an abrasive between the segments exposing the diamonds prematurely, wasting them.
		Use harder diamond matrix.	The harder segments don't expose as easily.
		Use tooling with more segments or area <sup>2</sup> of segment.	The tooling with more segments or area <sup>2</sup> doesn't have the same weight on them, reducing wear.
	The diamonds are too soft or too few.	Use weights on the handle	This reduces the weight on the diamonds thus reducing the wear on them.

**NOTE: THIS IS A GUIDE ONLY**



## Diamonds

	ST7-S08016	<b>8 Segment Diamond Wheel</b> For Hard Concrete / Soft Matrix • Colour - Black • Grit Size - 16# 10mm Segment
	ST7-S03016	<b>3 Segment Diamond Wheel</b> For Very Hard Concrete / Soft Matrix Colour - Grey • Grit Size - 16 # 10mm Segment
	ST7-H12030	<b>12 Segment Diamond Wheel</b> For Very Soft or abrasive concrete / Hard Matrix • Colour - Blue • Grit Size - 30/40# 10mm Segment
	ST7-H03030	<b>3 Segment Diamond Wheel</b> For Hard Concrete / Hard Matrix • Colour - Orange • Grit Size - 30/40# 10mm Segment
	ST7-S06030	<b>6 Segment Diamond Wheel</b> For Hard Concrete / Soft Matrix • Colour - Brown • Grit Size - 30/40# 10mm Segment

This list is only showing the Satellite 7" Disks, Many other types of tooling is available for polishing, Removal, cleaning, and even sanding timber. Contact your representative for more information or go to [www.floorex.com.au](http://www.floorex.com.au)

**Diamonds**

	<p>ST7-H09030</p>	<p><b>9 Segment Diamond Wheel</b>                  For Medium to Soft Concrete - Hard Matrix                  Colour - White                  Grit Size - 30/40#                  10mm Segment</p>
	<p>ST7-S03030</p>	<p><b>3 Segment Diamond Wheel</b>                  For Very Hard Concrete - Soft Matrix •                  Colour - Gold •                  Grit Size - 30/40#                  10mm Segment</p>
	<p>ST7-H09080</p>	<p><b>9 Segment Diamond Wheel</b>                  For Soft to Medium - Medium to Hard Matrix •                  Colour - Green •                  Grit Size - 80#                  10mm Segment</p>
	<p>ST7-H09150</p>	<p><b>9 Segment Diamond Wheel</b>                  For Soft to Medium - Medium to Hard Matrix •                  Colour - Red •                  Grit Size - 150#                  10mm Segment</p>
	<p>ST7-S09150</p>	<p><b>9 Segment Diamond Wheel</b>                  For Hard Concrete / Soft Matrix •                  Colour - Yellow •                  Grit Size - 150#                  10mm Segment</p>

This list is only showing the Satellite 7" Disks, Many other types of tooling is available for polishing, Removal, cleaning, and even sanding timber. Contact your representative for more information or go to [www.floorex.com.au](http://www.floorex.com.au)



Wiring Diagram

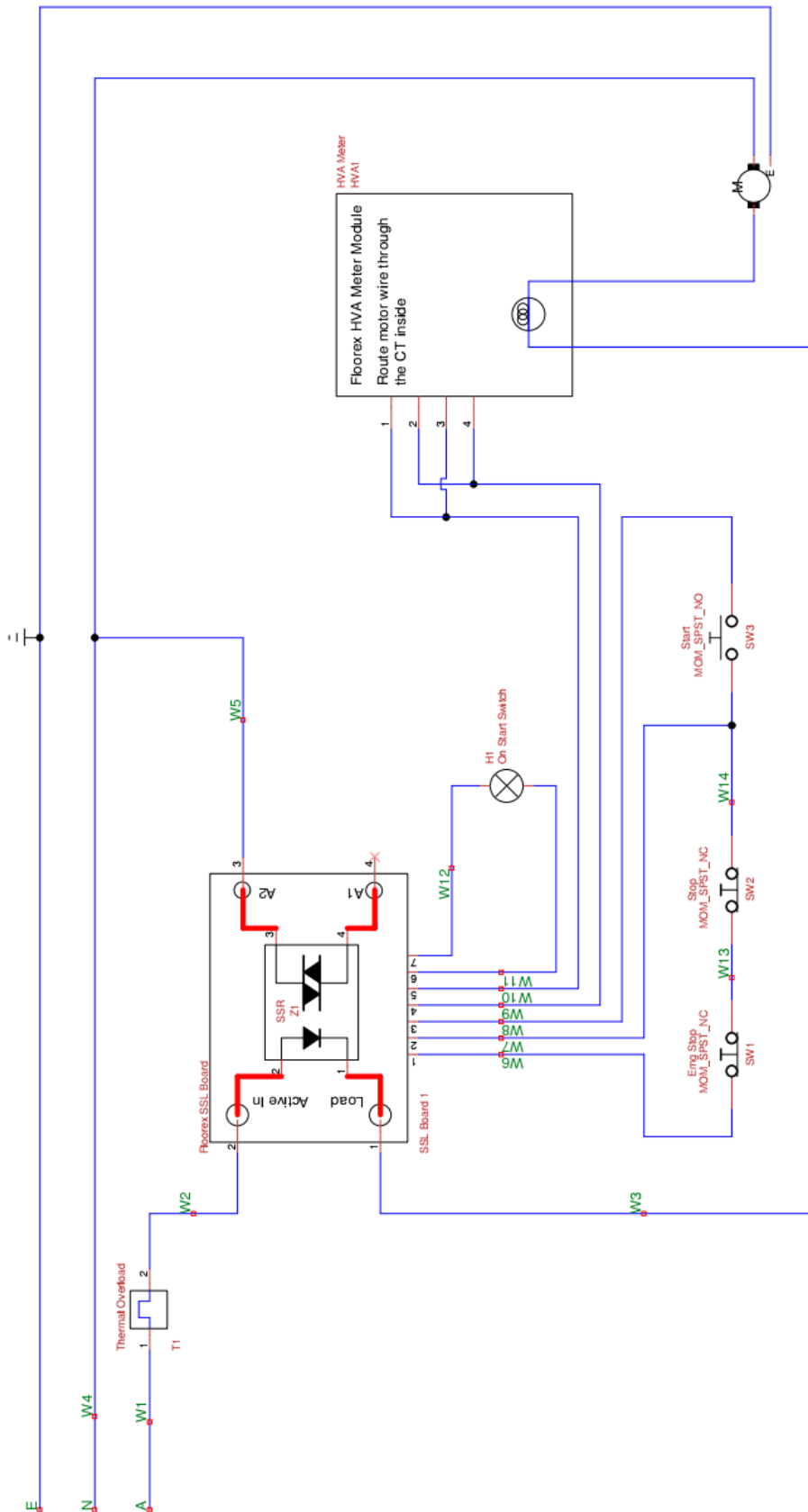

Title	SAT 480 Generation3 Wiring		
Author			
Floorex Products			
File	ams\Satellite_480 Generation3 Wiring_Digram.dsn		
Revision	Date		
1.0	07-01-2013	Sheets	1 of 1

Main Machine Breakdown

ITEM NO.	PartNo	DESCRIPTION	QTY.
1	G3-070	Motor 2.2kw 2P 1Ph	1
2	G3-059	Rubber Grommet Easy Fit 16	2
3	F3-225	12 X 40 Button Head	3
4	G3-006	480 Tooling Disk Complete (No Diamonds)	1
5	F3-309	M14 X 45 Hex Head Sel Screw	2
6	F3-334	M14 Standard Washer	4
7	F3-367	M14 Nyloc Nut	2
8	F3-319	M14 Spring Washer	2
9	G3-003	480 Main Chassis	1
10	G3-170	480 Axle Assembly Complete	1
11	G3-004	480 Upper Shroud	1
12	G3-005	480 Standard Main Handle Complete	1
13	G3-001	Transmission 8:1 90 Frame	1
14	F3-240	M8 X 50 Socket Head Cap Screw	1
15	G3-060	Cable Management Device 50mm	1
16	G3-008	Handle Spacer .55 Stainless	2
17	G3-064	480 Suction Tube	1
18	G3-063	Hose Clamp 40-64mm	1
19	G3-021	Satellite Mk3 weight	2
20	G3-193	Level Bubble Square	1
21	G3-194	Breather Cap	1
22	G3-068	480 One Piece Urethane	1

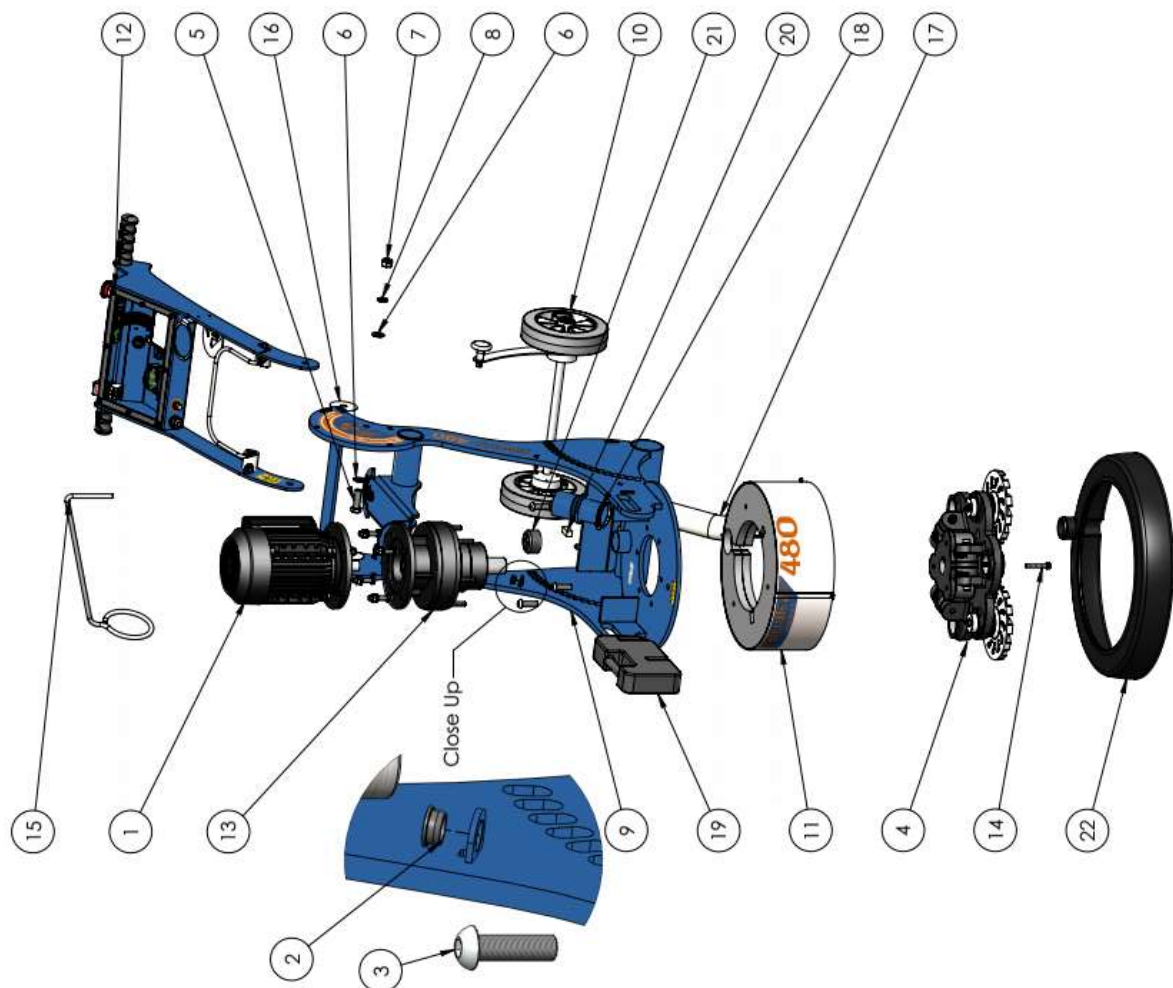

Handle Breakdown

ITEM NO.	PartNo	DESCRIPTION	QTY.
1	G3-032	SSR 80 A 240V	1
2	F3-230	M6 X 10 Socket Head Cap Screw	8
3	G3-050	Rubber handle Grip	2
4	G3-029	Protective Boot for Start Stop Switch	1
5	G3-030	Start Stop Switch Complete	1
6	G3-033	SSL board	1
7	G3-048	Overload 15A	1
8	G3-049	Overload Boot	1
9	G3-037	Gland With Support PG21	1
10	F3-266	M6 X 16 Socket Head Countersunk Screw	4
11	G3-059	Rubber Grommet Easy Fit 16	2
12	G3-036	Cable Gland M20	1
13	G3-027	480 Enclosure Lid	1
14	G3-180	480 Lock Mechanism Complete	1
15	G3-002	Safellite Mk3 480 Handle Welded	1
16	G3-041	HVA Meter Screen Assembly	1
17	G3-031	Emergency Stop Switch Complete	1
18	F3-203	M4 X 10 Screw Pan Head Phillips	4
19	G3-040	HVA Meter Main Module	1
20	F3-202	M4 X 6 Screw Pan Head Phillips	2
21	G3-027	480 Enclosure Lid Seal	1
22	G3-199	Drink Holder	1
23	G3-035	Plastic P Clip 12mm	1

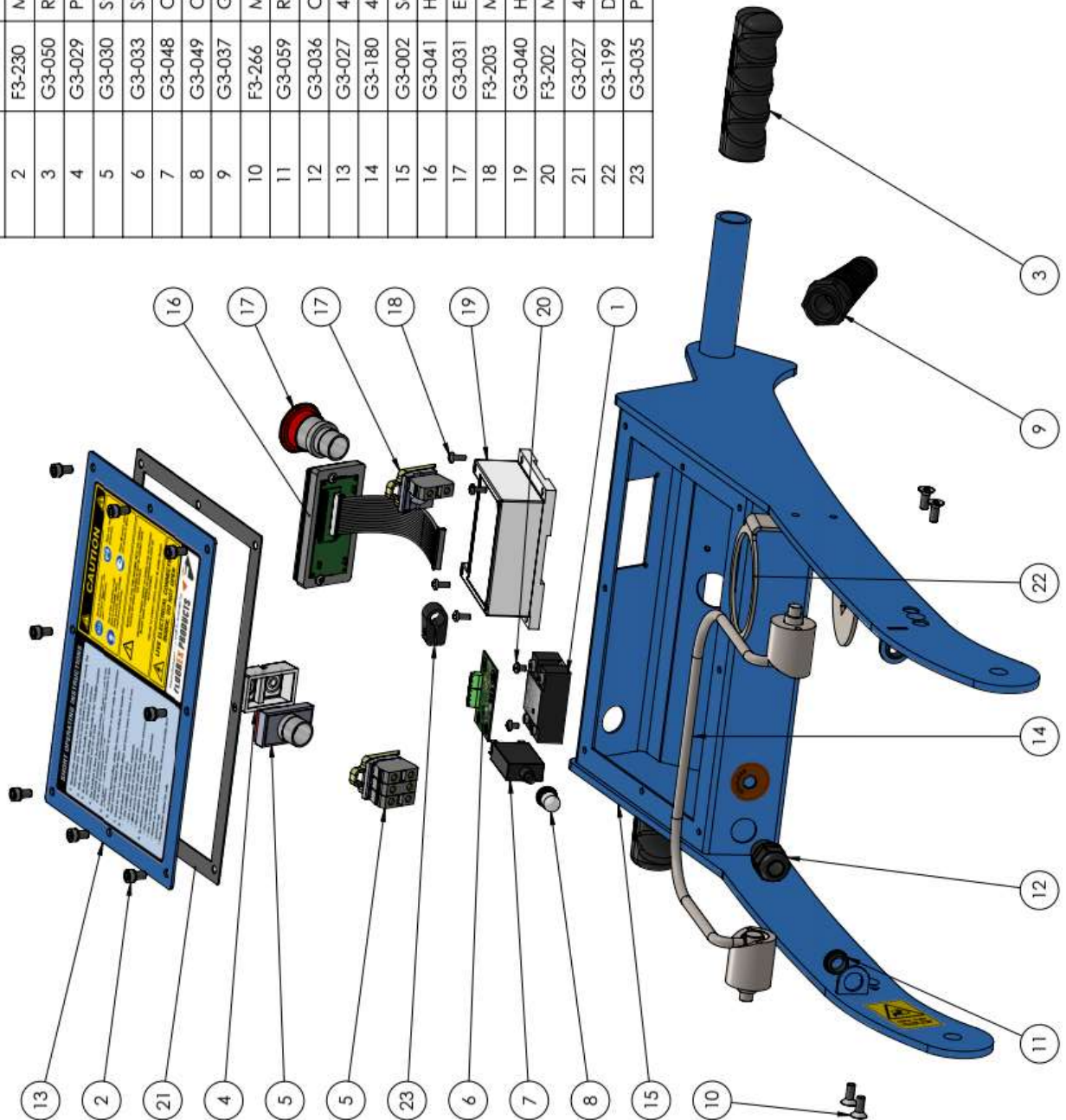

Disk Breakdown

ITEM NO.	PartNo	DESCRIPTION	QTY.
1	G3-100	Drive Hub	1
2	G3-102	Coupling Rubber	3
3	G3-101	Tooling Disk	1
4	G3-103	Torque Rubber	6
5	F3-247	M10 X 30 Socket Head Cap Screw	6
6	F3-317	M10 Spring Washer	9
7	F3-345	M10 Standard Nut	3
8	G3-107	Magnetic Plug	3
9	G3-108	Insert Version 4	3
10	ST7 XXXXXX	Satellite Disk	3
11	S3-016	Magnet for Plug	3

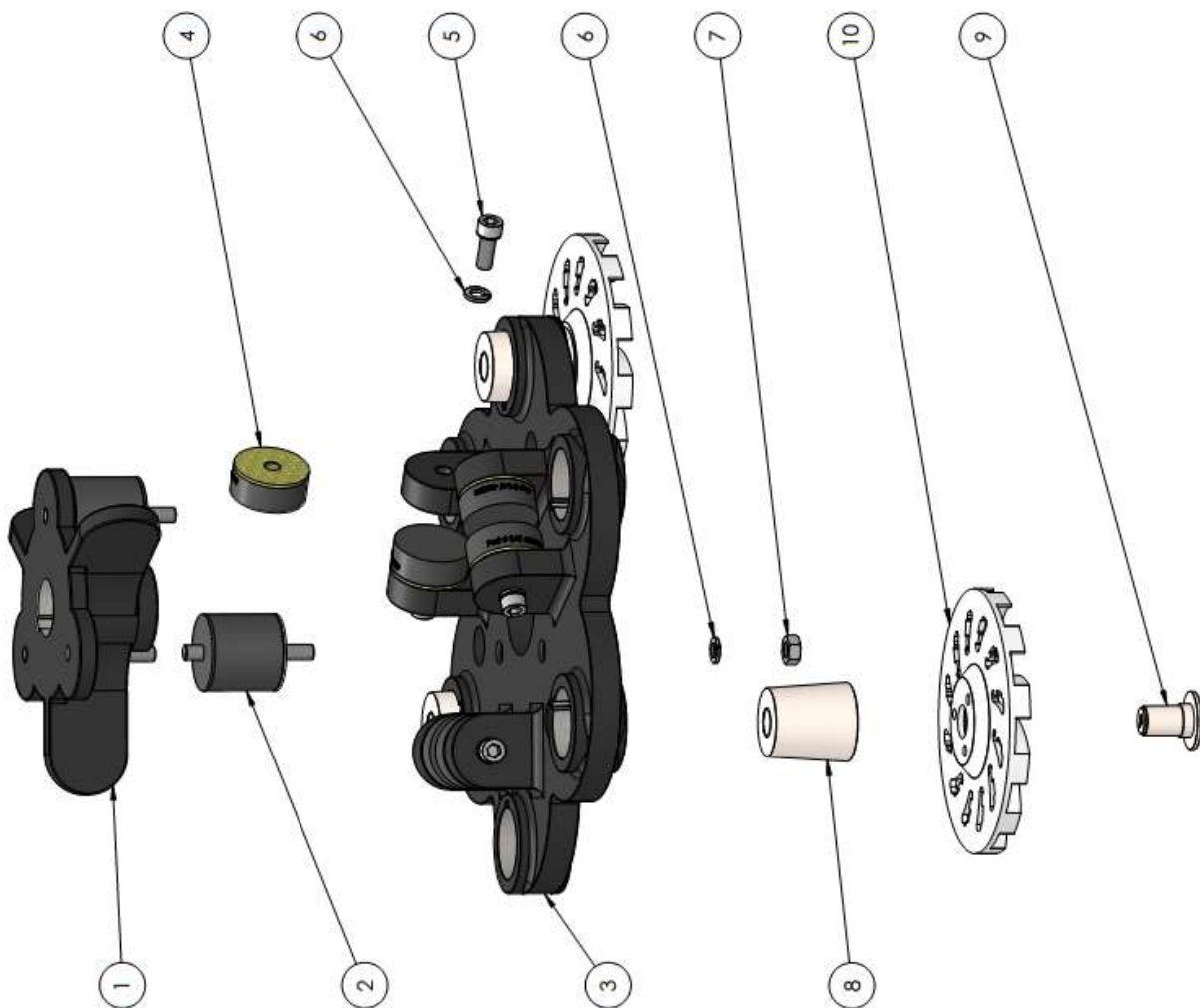

Handle Lock Breakdown

ITEM NO.	PartNo	DESCRIPTION	QTY.
1	G3-183	480 Lock Mechanism Handle	1
2	G3-182	Lock Mechanism Pin	2
3	G3-181	Lock Mechanism Cam	2
4	G3-185	Circlip 8mm	4

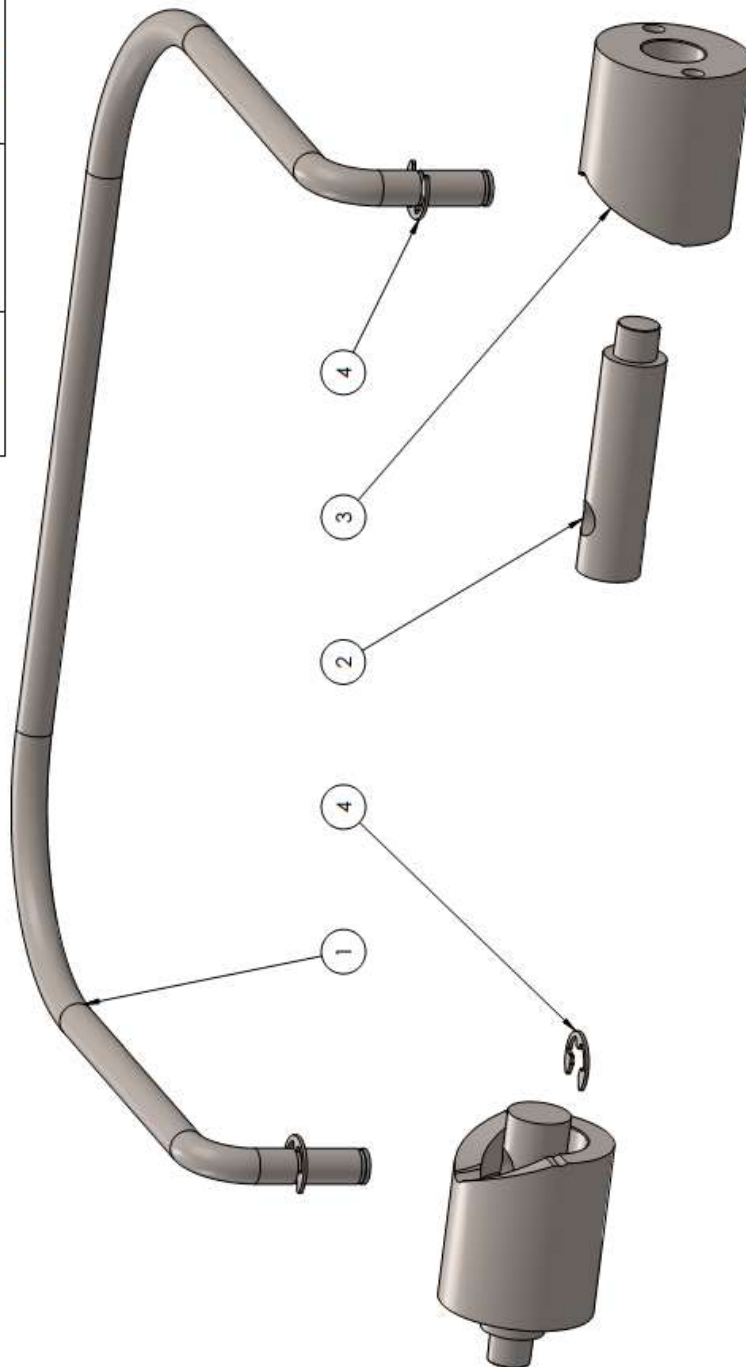



Motor Breakdown

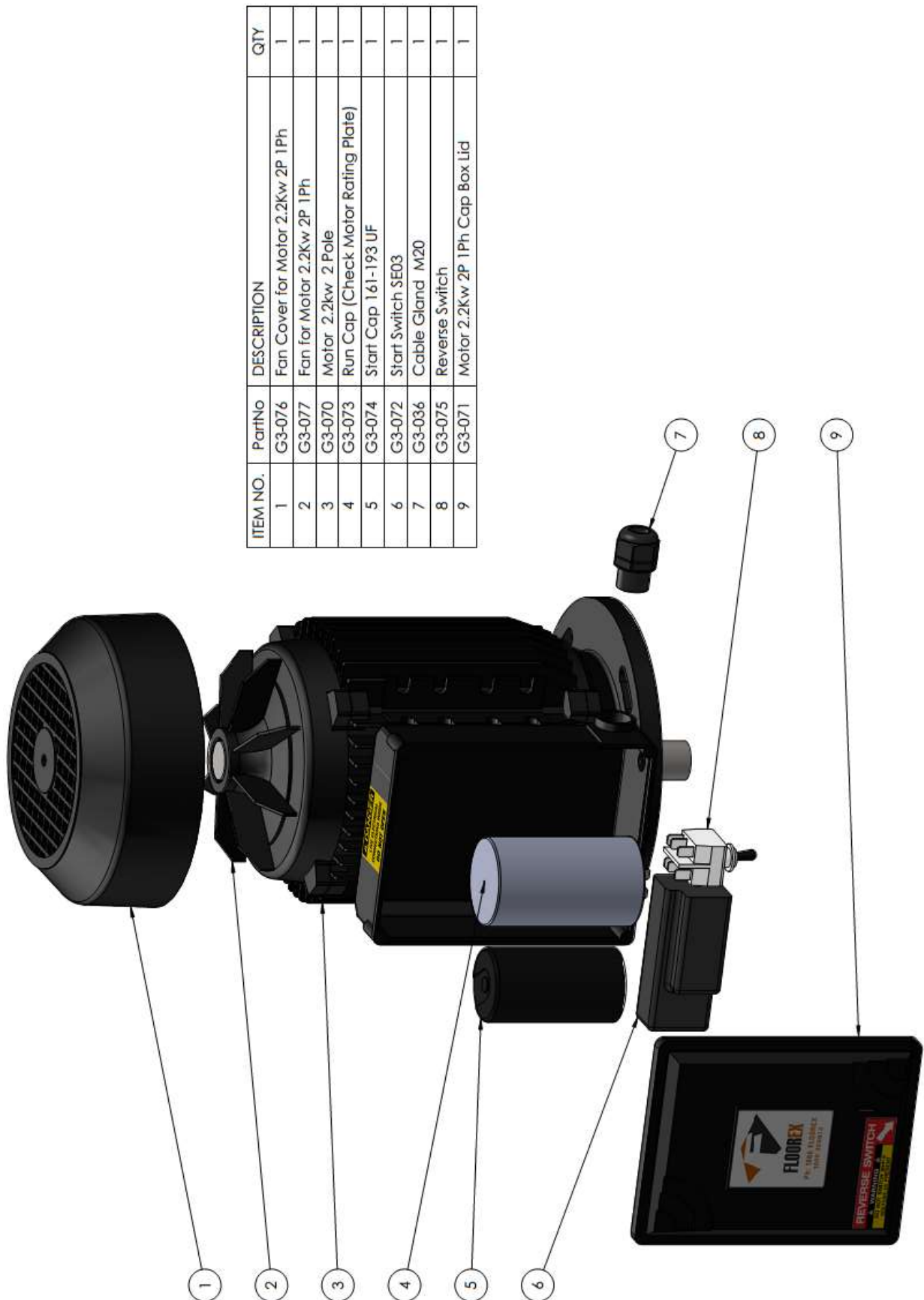

ITEM NO.	PartNo	DESCRIPTION	QTY
1	G3-076	Fan Cover for Motor 2.2Kw 2P 1Ph	1
2	G3-077	Fan for Motor 2.2Kw 2P 1Ph	1
3	G3-070	Motor 2.2kw 2 Pole	1
4	G3-073	Run Cap (Check Motor Rating Plate)	1
5	G3-074	Start Cap 161-193 UF	1
6	G3-072	Start Switch SE03	1
7	G3-036	Cable Gland M20	1
8	G3-075	Reverse Switch	1
9	G3-071	Motor 2.2Kw 2P 1Ph Cap Box Lid	1

Axle Breakdown

ITEM NO.	PartNo	DESCRIPTION	QTY
1	F3-240	M8 X 30 Socket Head Cap Screw	1
2	F3-315	M6 Spring Washer	6
3	F3-335	M18 Standard Washer	4
4	F3-268	M10 X 25 Socket Head Countersunk Screw	2
5	G3-171	480 Axle	1
6	G3-174	200mm Wheel	2
7	G3-173	Axle Retainer	1
8	G3-172	Axle Lever	1
9	F3-210	6 X 12 Button Head	6
10	G3-175	Generation3 Stainless Axle Knob	1
11	G3-178	Generation3 Stainless Axle Knob Spacer	1

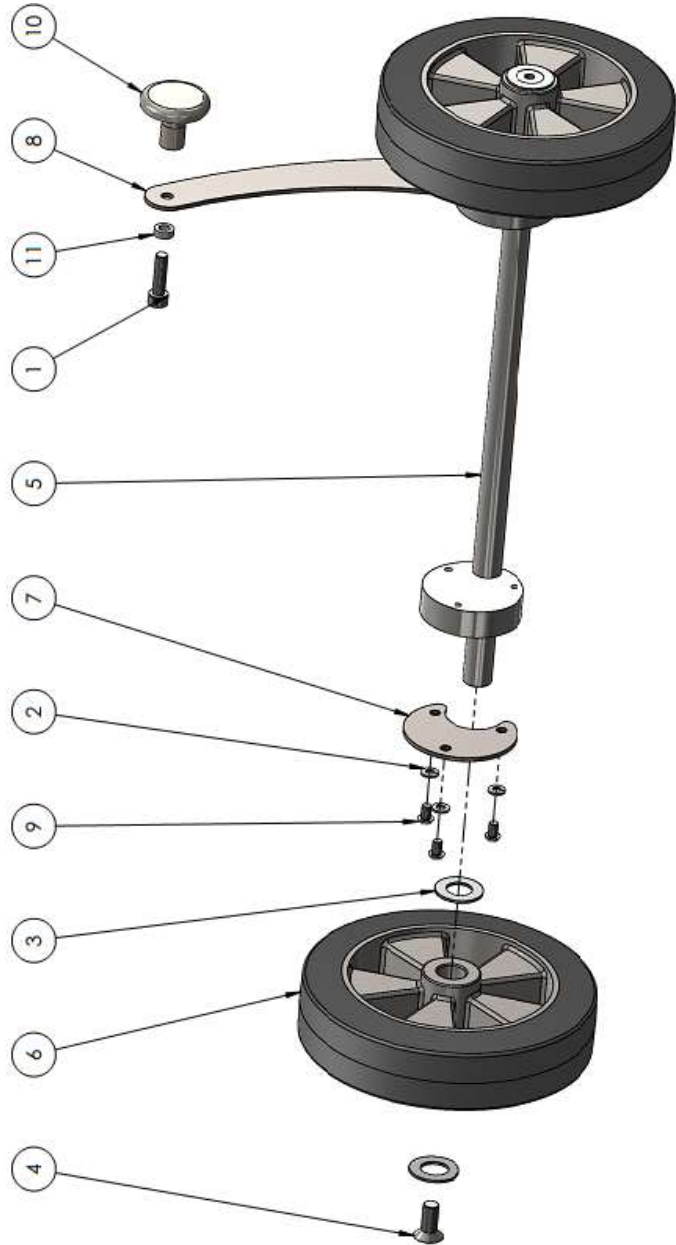

Screen Breakdown

ITEM NO.	PartNo	DESCRIPTION	QTY.
1	F3-380	M3 X10 Flat Head Phillips Screw	4
2	G3-042	HVA Meter Screen Clamp	1
3	G3-043	HVA Meter Screen Lens	1
4	G3-044	HVA Meter Screen Seal	1
5	G3-045	Screen Mount Block	1
6	G3-046	HVA Meter Screen only	1
7	F3-202	M4 X 6 Screw Pan Head Phillips	2
8	G3-046	HVA Meter Screen only	1
9	G3-039	HVA Meter Ribbon Cable	1

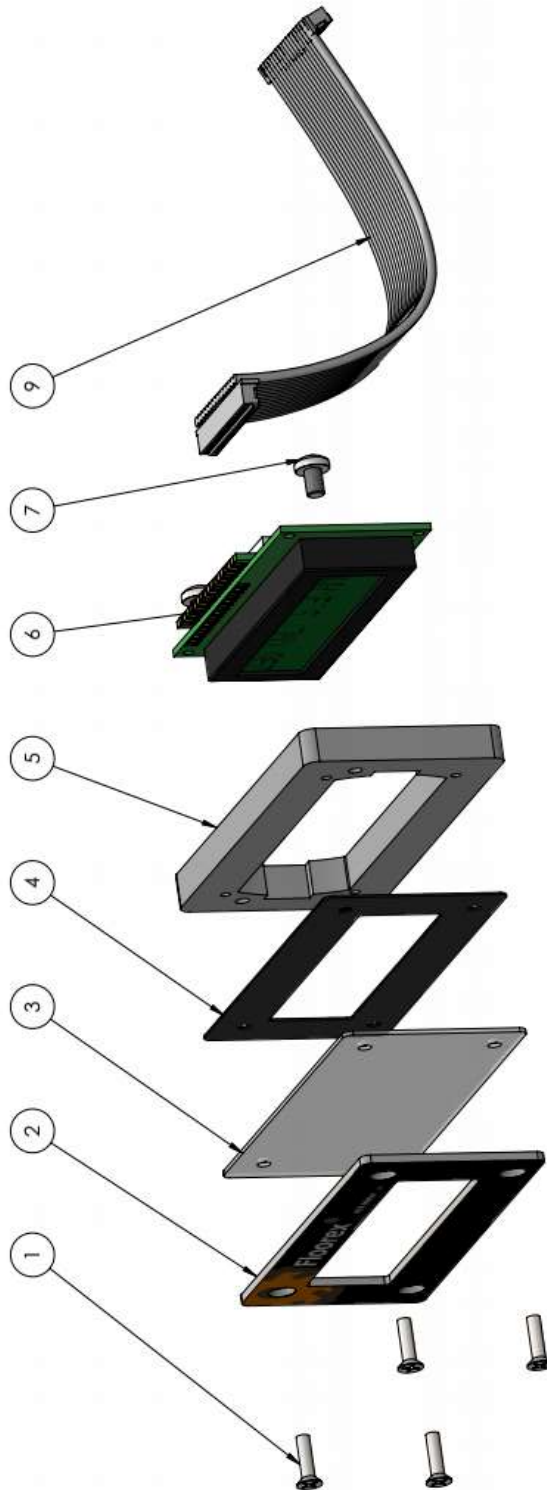



Shroud Breakdown

ITEM NO.	PartNo	DESCRIPTION	QTY.
1	G3-065	Stainless Shroud Ring with Part	1
2	G3-067	Shroud Polyurethane Skirt	1
3	G3-066	Shroud Seal Rubber	1
4	F3-207	5 X 25 Button Head	9
5	F3-362	M5 Nyloc Nut	9
6	F3-329	M5 Standard Washer	9

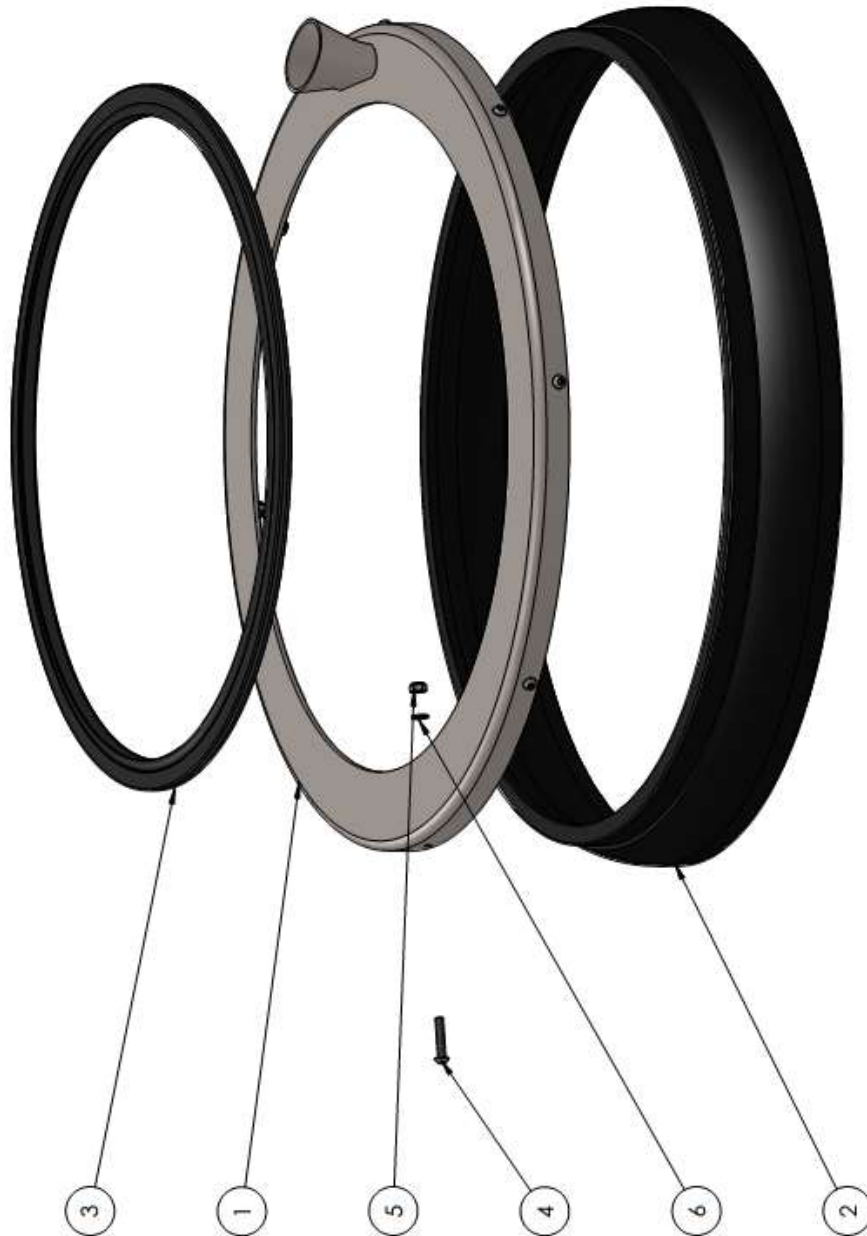

SP Plug Breakdown (for SP machines only)

ITEM NO.	PartNo	DESCRIPTION	QTY.
1	F3-267	M8 X 16 Socket Head Countersunk Screw	1
2	G3-117	SP Plug Top Retaining Washer	1
3	G3-120	SP Plug Rubber Tyre 120mm	1
4	G3-118	SP Plug Stacking Cogs	6
5	G3-119	SP Plug Bottom Retaining Washer	1
6	G3-114	Ball Bearing 6203 DDU	4
7	G3-116	SP Plug Main Body	1
8	G3-115	SP Plug Main Shaft	1
9	G3-123	SP Plug Drive Pin	1
10	G3-124	SP Plug Disc Retaining Rubber Ring	1
11	G3-122	SP Plug Complete (items 6-9)	1

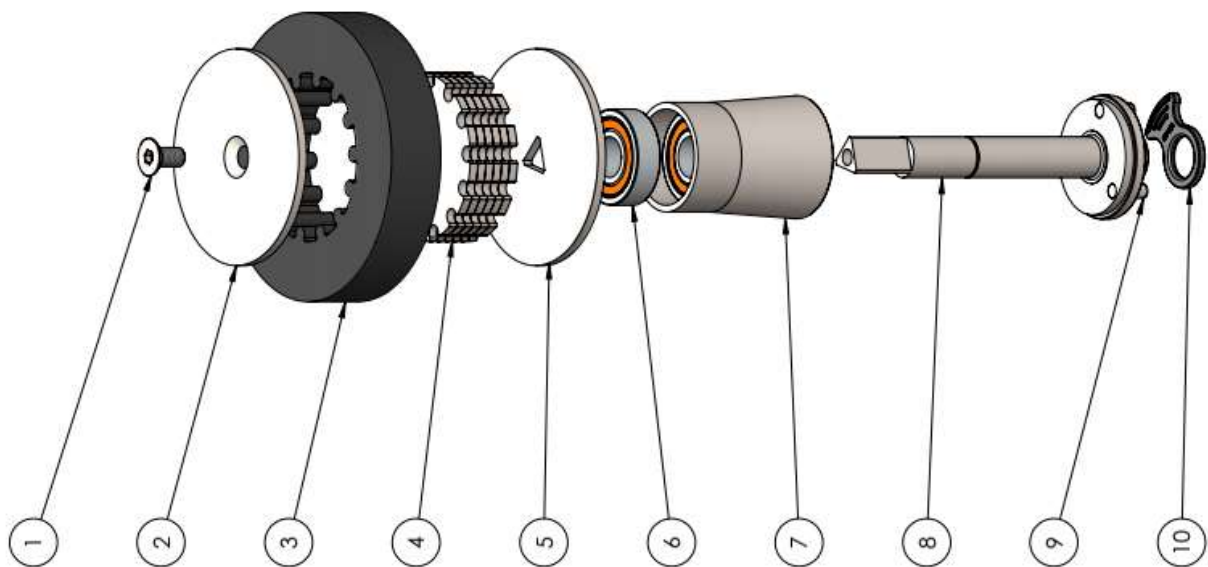

SP Drive Boss Breakdown (for SP machines only)

ITEM NO.	PartNo	DESCRIPTION	QTY.
1	G3-122	SP Drive Boss Mount	6
2	G3-121	SP Drive Boss	1
3	F3-232	M6 X 40 Socket Head Cap Screw	6

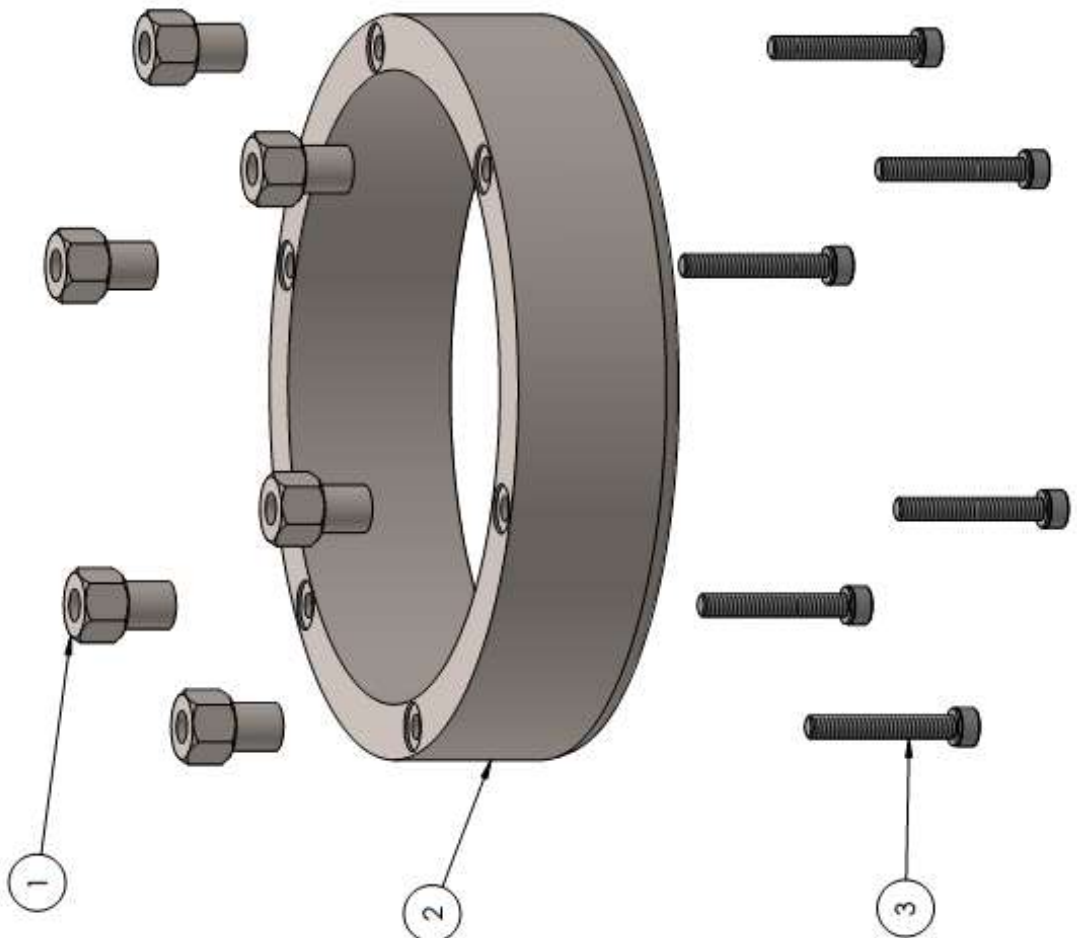

SP Shrouds Breakdown (for SP machines only)

ITEM NO.	PartNo	DESCRIPTION	QTY.
1	G3-023	480 SP Shroud Upper	1
2	G3-069	480 SP One Piece Urethane Shroud	1



### Warranty

This Warranty covers the Satellite Generation3 Machines for periods noted in the table below.

Machine/Item	Period	Notes and additional Options
All Satellite Generation 3 machines	2 years	
Cycloid Transmissions (excludes satellite 380 model)	2 years	An extra 3 years is offered, extending warranty to 5 years for no cost if machine is registered at: <a href="http://floorex.com.au/register.html">http://floorex.com.au/register.html</a> Terms and conditions apply.
Inverters or Speed Controllers	2 year or 500 hours or as per manufacturer's warranty*	
Petrol Motors	Manufacturer's warranty	Warranted by the motor manufacturer

\* Whichever comes first

All Satellite Machines are offered with a 2 year Limited manufacturer's Warranty against defects. This does not mean the machine is indestructible or will not require replacement parts as there are some parts which are normal replacement items and the wear is not a fault of manufacture. The hour meter on the machine is for the consumer's reference and not necessarily to measure warranty periods. Floorex or their nominated repairers will assess any problem irrespective of the hour meter at their discretion.

Our goods come with guarantees that cannot be excluded under the Australian Consumer Law. You are entitled to a replacement or refund for a major failure and compensation for any other reasonably foreseeable loss or damage. You are also entitled to have the goods repaired or replaced if the goods fail to be of acceptable quality and the failure does not amount to a major failure.

As these goods are not of a kind ordinarily acquired for domestic, household or personal use, Floorex is entitled to limit their liability to sellers (companies or individuals who resell the machine) to the cost of replacing the goods, having the goods repaired or obtaining equivalent goods (whichever is lowest).

Consumer Guarantees are a contract between the seller and the consumer. For this reason if goods are purchased to be resold or to be transformed into a product that is sold, the consumer guarantees between Floorex and the re-seller will not apply.

Compensation - Manufacturers are not responsible for problems with goods beyond their control. For this reason Floorex will not be held liable for:

1. An act, default, omission or representation made by some other person (excluding an employee or agent of the manufacturer).
2. Contract penalties such as promises for completion date of jobs. These are at the risk of the parties involved.
3. A cause independent of human control that occurs after the goods left the manufacturer's control

The consumer guarantees require you to return goods to the place where they were purchased unless it is not reasonable for you to do so. For example, it would be reasonable to expect you to return an item if you would be able to easily take it away with you when you purchased it. However, if the item is large, heavy or bulky or needed to be delivered, the seller should arrange for this to be returned.

For this reason for timely repairs and as little downtime for the consumer, Floorex may offer to have the machine repaired by a nominated repairer close by.



Register Your Machine  
for Extended Warranty



## Floorex Products

Your complete supplier  
of all your concrete  
surface preparation  
needs

- Diamond grinders
- Dust extraction
- Shotblasters
- Screed mixers
- Diamonds
- Floor Scrapers
- Coating application

FLOOREX  
PRODUCTS  
11 Jennings Road  
Swan Hill VIC.  
3585

Web: [www.floorex.com.au](http://www.floorex.com.au)  
Email: [sales@floorex.com.au](mailto:sales@floorex.com.au)