

Machine Rating

Rated operating capacity	457 kg
Tipping load	915 kg
Pump capacity	50 l/min
System relief at Quick Couplers	207 bar
Max. travel speed	10.4 km/h

Engine

Make / Model	Kubota / V1505-E2B-BCZ
Fuel / Cooling	Diesel / Liquid
Maximum power at 3000 RPM (SAE J1349)	25 kW
Torque at 1700 RPM (SAE J1349)	93 Nm
Number of cylinders	4
Displacement	1498 mm
Fuel tank capacity	45 l

Weights

Operating weight (with std tyres, 48 inch bucket)	1800 kg
Operating weight (with hd tyres, 50 inch bucket)	1818 kg

Controls

Vehicle steering	Direction and speed controlled by two hand levers
Loader hydraulics tilt and lift	Separate foot pedals
Front auxiliary (standard)	Lateral movement of right-hand steering lever

Drive System

Transmission	Infinitely variable tandem hydrostatic piston pumps, driving two fully reversing hydrostatic motors
--------------	-----------------------------------------------------------------------------------------------------

Standard Features

Automatically activated glow plugs	Parking brake
High-back cushion suspension seat	Seat belt
Bob-Tach™ frame	Seat bar
Engine / Hydraulic system shutdown	Spark arrestor muffler
Bobcat Interlock Control System (BICS)	27 x 8.50-15, 6-ply, Bobcat heavy duty tyres
Operating lights, front and rear	CE certification
Instrumentation	
Lift arm support	
Operator cab Deluxe*(♦)	

* Roll Over Protective Structure (ROPS) – meets requirements of SAE-J1040 and ISO 3471; Falling Object Protective Structure (FOPS) - meets requirements of SAE-J1043 and ISO 3449, Level I

♦ Cab Deluxe includes interior cab foam, top and rear windows, deluxe wire harness, domelight and electrical power port

Options

Deluxe instrument panel	Hydraulic bucket positioning (including ON/OFF switch)
Heated enclosed cab	Counterweights
Power Bob-Tach™	

Dimensions

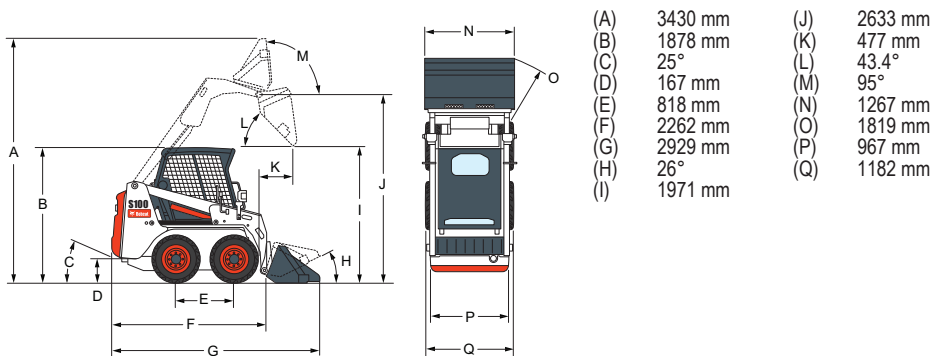

Attachments

- Angle blade (snow blade)
- Angle broom*†
- Auger
- Buckets
- Cutter crusher*
- Digger
- Dumping hopper
- Front scarifier
- Grapples and forks
- Hydraulic breaker**
- Landplane
- Loader X-Change™ frame (for breaker)
- Pallet forks
- Scraper
- Snow blower*
- Soil conditioner*
- Sweeper
- Three-point hitch
- Tiller
- Tilt-Tach
- Trencher

*Attachment control kit required.

**When operating the loader with this attachment, a Special Applications Kit, which includes a 12 mm Lexan front door with 6 mm top and rear windows, must be used.

†Optional water kit.

Specifications and design are subject to change without notice. Pictures of Bobcat products may show other than standard equipment.

www.bobcat.eu



Bobcat®

