

**WILCOX<sup>®</sup>**



**PRODUCT BROCHURE**





**Wilcox Xe** laser aiming devices and fire control systems are smaller, lighter, stronger and smarter devices that provide superior, uncompromising performance and the ultimate in beam clarity. The Wilcox Xe product line increases precision and range while simultaneously decreasing target engagement time. Whatever the conditions Wilcox Xe products can calculate corrections with speed and efficiency, increasing first round hit capability.

Today's combat operations dictate an ability to generate tempo at all levels. Our systems approach integrates our robust line of combat systems with the real time network created by Blueforce Development. These networking capabilities are available on Wilcox Xe products\*, provide actionable, task relevant information and give operators superior maintenance and replenishment connectivity. These distinct advantages increase lethality and situational awareness for today's operators.

[www.wilcoxind.com/Xe-Products](http://www.wilcoxind.com/Xe-Products)

LASER AIMING DEVICES  
FIRE CONTROL SYSTEMS  
WEAPON SOLUTIONS  
BTAC





## BTAC™ NETWORKED ENABLED CAPABILITY

- Providing actionable, task relevant information to and from networked teammates.
- Shot counter: Monitors shot count which is shared in real time with other users and the Armorer's Module for BlueforceCOMMAND.
- Temperature monitoring: Monitors weapon temperature and can forward based on high and low thresholds.
- Health/power: Monitors and reports maintenance flags or issues as part of the movement of shots, temperature, and location.
- Orthogonal sensor cueing allows the Wilcox BOSS Xe Plugin for BTAC to communicate with other BTAC plugins allowing image capture enabled sights to pass images to BTAC Cognitive Services Plugin for identification and real-time sharing.
- Offline queue: BTAC will hold presence packets when connectivity is denied. When BTAC sees an approved network, it forwards packets cached during offline operations.
- Network friendly Selective synchronization: Plugin may be configured to send ALL shot records, OR, only send those where shot count and/or temperature changes.

# BOSS X<sub>e</sub>

BALLISTICALLY OPTIMIZED SIGHTING SYSTEM - ENHANCED - HIGH POWER



## OVERVIEW

The Wilcox BOSS Xe™ is the next generation in the BOSS line of products. The BOSS Xe is a high power laser aiming device that houses a reflex sight, red or green visible laser, NIR laser illuminator, and iron sight all co-aligned to one another. The fixed NIR illuminator, combined with the newly added NIR room illuminator, features best in class overall effective tactical solution in any low light combat situation.

Decisively designed for the assaulter, the BOSS Xe differentiates itself from any other reflex sight on the market. The user can fire both supersonic and subsonic ammunition from the same weapon by simply flipping a trajectory switch that changes the point of aim and point of impact of each round fired without having to re-zero the weapon. This product is available in a red or green laser configuration.

Download technical data, additional resources and request pricing at [www.wilcoxind.com/BOSS-Xe](http://www.wilcoxind.com/BOSS-Xe)



## TECH INSIDE

Download our technical brief, "Investments in Optical and Laser Technologies Increase Effectiveness and Lethality"

[www.wilcoxind.com/BOSSXe-Brief](http://www.wilcoxind.com/BOSSXe-Brief)



OFF CANT INDICATOR

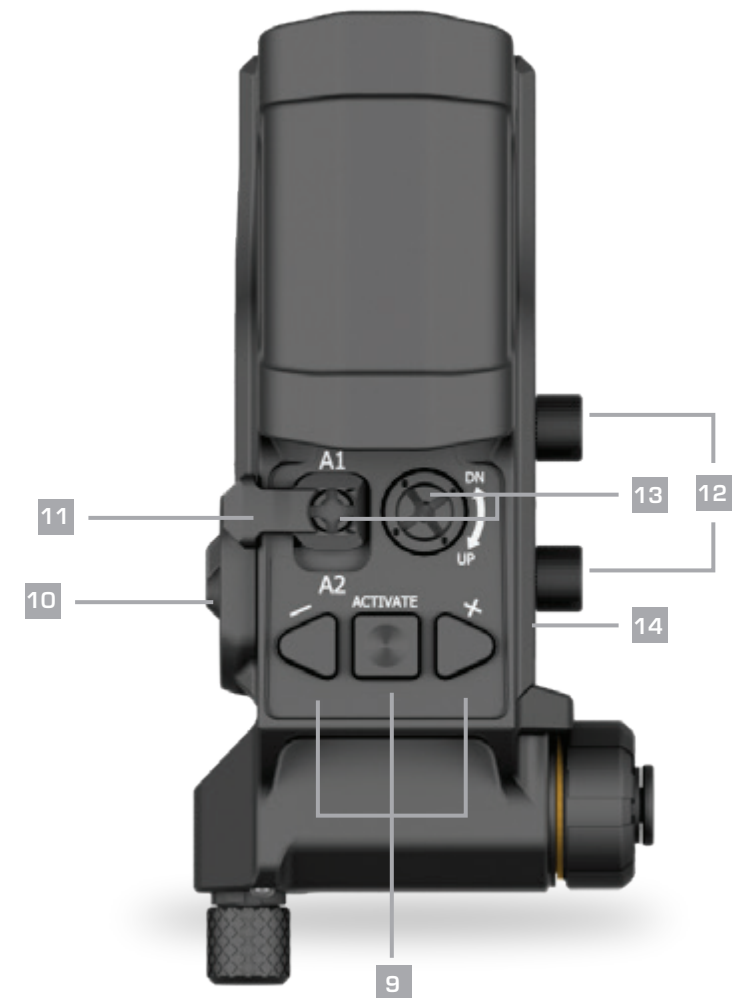
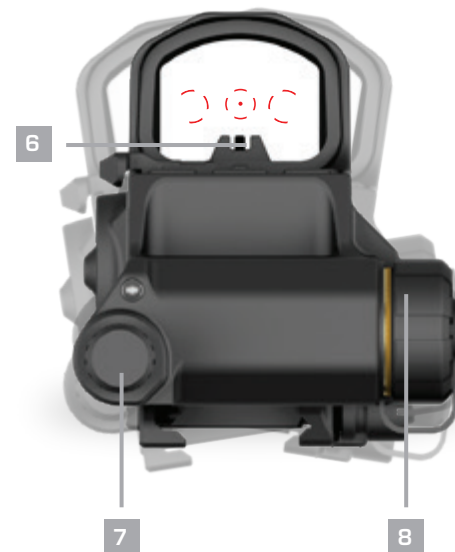

## FEATURES & BENEFITS

1. Reflex Sight
2. NIR Laser
3. NIR room Illuminator
4. NIR fixed Illuminator
5. Red/Green VIS Laser
6. Built-in Back Up Iron Sights
7. Remote Control Activation Pad Port
8. Battery Compartment
9. Reflex/Laser/Illuminator Brightness Control
10. Mode Selector Switch
11. Trajectory Switch
12. Shock Nuts Picatinny Mount
13. Elevation Adjustment for Zero Presets 1 & 2
14. Windage Adjustment (not visible)

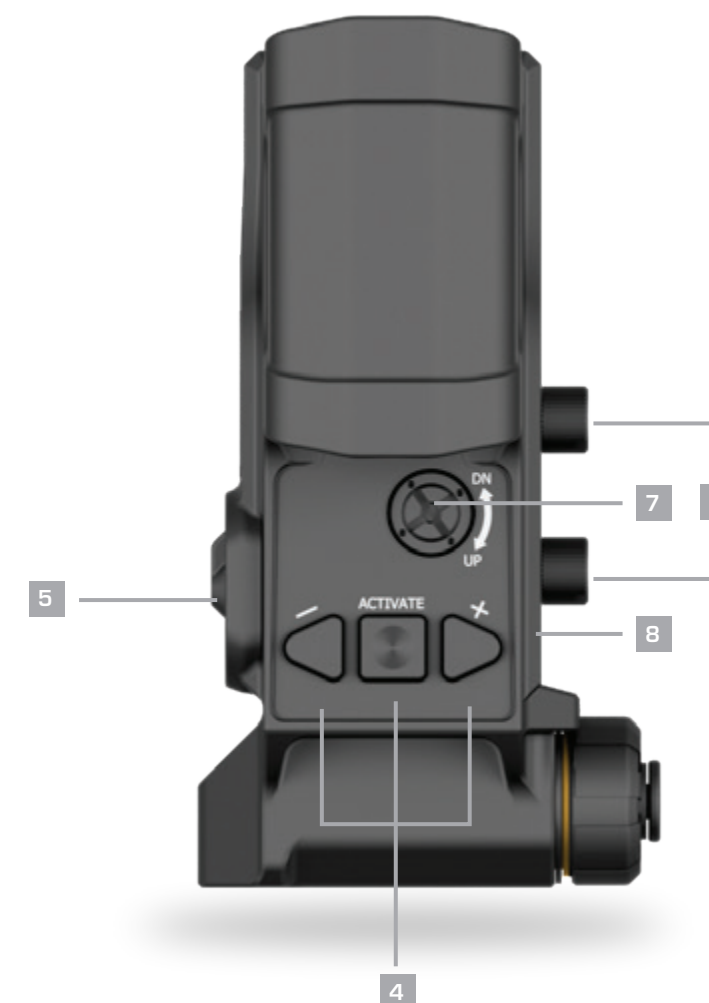
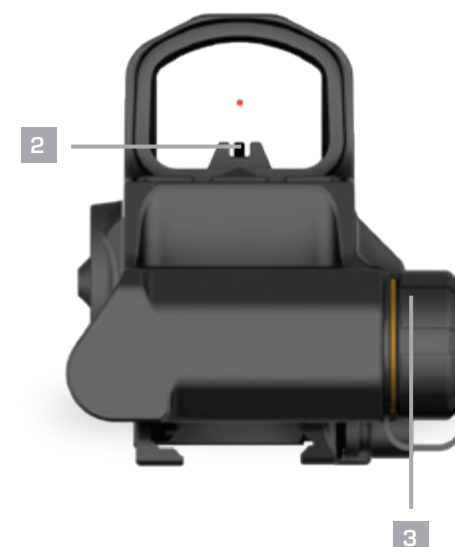
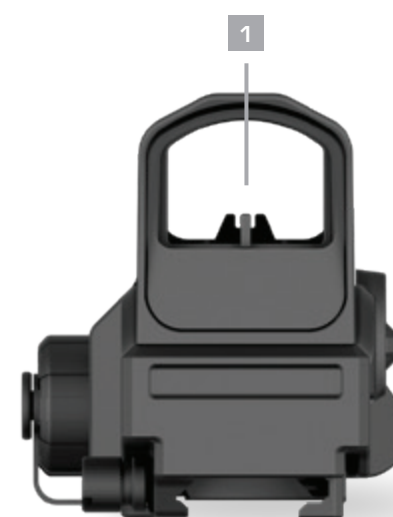

**BOSS MXe**BALLISTICALLY OPTIMIZED SIGHTING  
SYSTEM - MOD - ENHANCED**BTAC™**  
NETWORKED  
ENABLED CAPABILITY

- Providing actionable, task relevant information to and from networked teammates.
- Shot counter: Monitors shot count which is shared in real time with other users and the Armorer's Module for BlueforceCOMMAND.
- Temperature monitoring: Monitors weapon temperature and can forward based on high and low thresholds.
- Health/power: Monitors and reports maintenance flags or issues as part of the movement of shots, temperature, and location.
- Orthogonal sensor cueing allows the Wilcox BOSS MXe Plugin for BTAC to communicate with other BTAC plugins allowing image capture enabled sights to pass images to BTAC Cognitive Services Plugin for identification and real-time sharing.
- Offline queue: BTAC will hold presence packets when connectivity is denied. When BTAC sees an approved network, it forwards packets cached during offline operations.
- Network friendly Selective synchronization: Plugin may be configured to send ALL shot records, OR, only send those where shot count and/or temperature changes.

**OVERVIEW**

The Wilcox BOSS MXe™ is the next generation in the BOSS line of products. The BOSS MXe features a fully integrated, environmentally stable optical bench that houses a reflex sight and iron sight all co-aligned to one another.

Decisively designed for the assaulter, the BOSS MXe differentiates itself from any other reflex sight. Wilcox has set the standards for optical performance in distortion, clarity and uniformity, aiding in increasing the warfighter's lethality and situational awareness.

Download technical data, additional resources and request pricing at [www.wilcoxind.com/BOSS-MXe](http://www.wilcoxind.com/BOSS-MXe)

**FEATURES & BENEFITS**

1. Reflex Sight
2. Built-in Back Up Iron Sights
3. Battery Compartment
4. Brightness Control
5. Mode Selector Switch
6. Shock Nuts Picatinny Mount
7. Elevation Adjustment
8. Windage Adjustment (not visible)





## RUGGEDIZED AIMING/ILLUMINATION DEVICE - ENHANCED - HIGH POWER

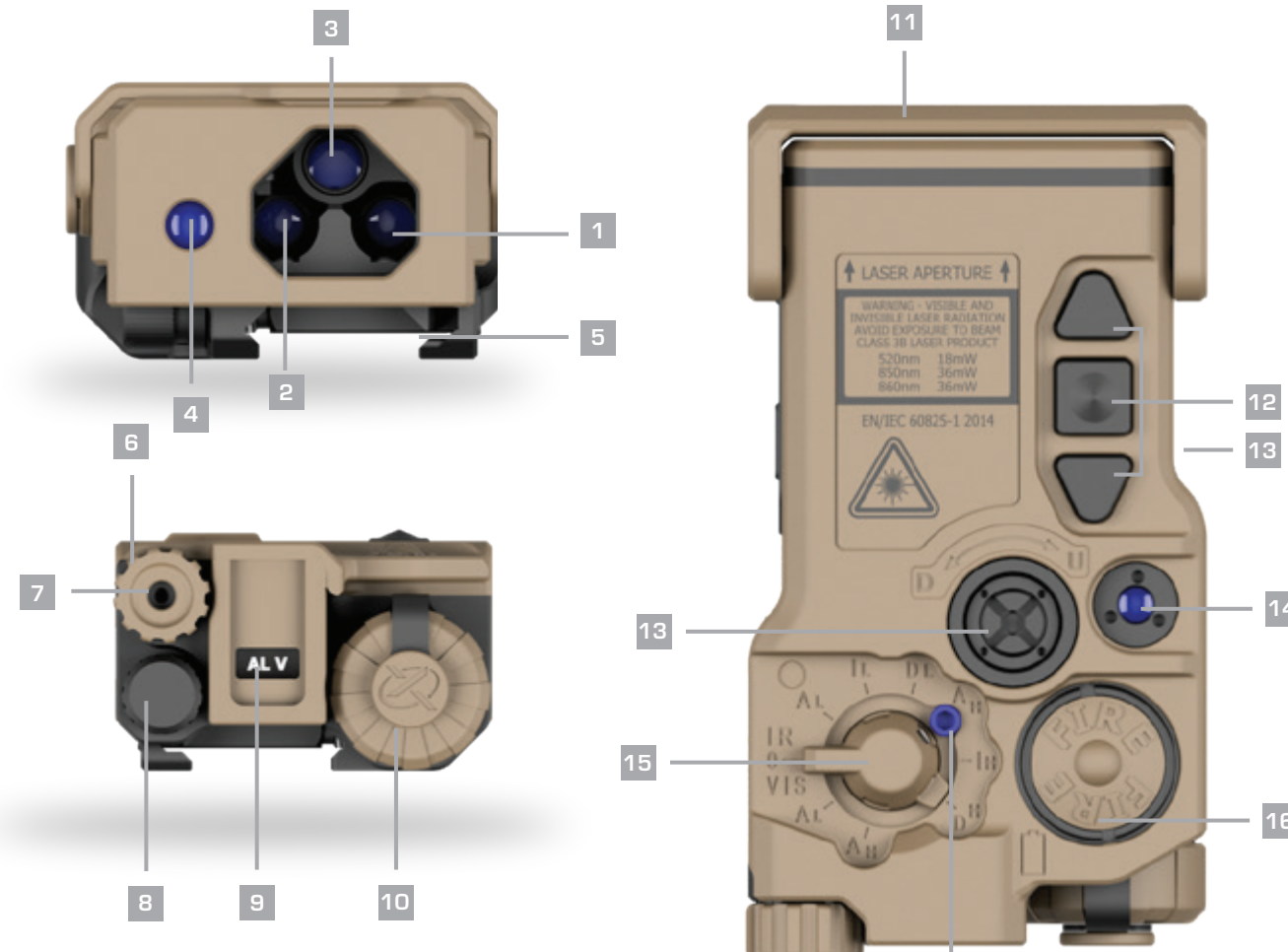

LASER SAFETY VISOR



RUBBER LASER SAFETY COVER



### BTAC™ NETWORKED ENABLED CAPABILITY

#### SENSOR TO SHOOTER ADVANTAGE

- Providing actionable, task relevant information to and from networked teammates.
- Shot counter: Monitors shot count which is shared in real time with other users and the Armorer's Module for BlueforceCOMMAND.
- Temperature monitoring: Monitors weapon temperature and can forward based on high and low thresholds.
- Health/power: Monitors and reports maintenance flags or issues as part of the movement of shots, temperature, and location.
- Orthogonal sensor cueing allows the Wilcox RAID Xe Plugin for BTAC to communicate with other BTAC plugins allowing image capture enabled sights to pass images to BTAC Cognitive Services Plugin for identification and real-time sharing.
- Offline queue: BTAC will hold presence packets when connectivity is denied. When BTAC sees an approved network, it forwards packets cached during offline operations.
- Network friendly Selective synchronization: Plugin may be configured to send ALL shot records, OR, only send those where shot count and/or temperature changes.

#### OVERVIEW

The Wilcox RAID Xe™ is the next generation in the RAID line of products. The RAID Xe is a class 3B high power laser aiming device designed for assault and crew served weapons. The RAID Xe provides a smaller, lighter, stronger laser aiming device with superior, uncompromising performance. The ultimate beam clarity and uniformity aide rapid target acquisition and the built-in networking capabilities give the RAID Xe superior maintenance and replenishment connectivity, all increasing the warfighter's lethality and situational awareness.

This product is available in either red or green laser configurations. The NIR room illuminator combined with the existing variable NIR illuminator features best in class overall effective tactical solution in any low light combat situation. The ergonomic illuminator spool location allows easy rapid adjustment of the NIR illuminator beam divergence for variable distances and mission requirements.

Download technical data, additional resources and request pricing at [www.wilcoxind.com/RAID-Xe](http://www.wilcoxind.com/RAID-Xe)



#### TECH INSIDE

Download our technical brief, "Enhanced Laser Tech & Networking Abilities Give Operators The Tactical Edge"

[www.wilcoxind.com/RAIDXe-Brief](http://www.wilcoxind.com/RAIDXe-Brief)

#### FEATURES & BENEFITS

1. Red/Green VIS Laser
2. NIR Laser
3. NIR Variable Illuminator
4. NIR fixed Room Illuminator
5. MIL-STD-1913/NATO STANAG Interface
6. NIR Illuminator Divergence Knob
7. High Power Lockout Screw Storage
8. Remote/Pressure Pad Port
9. OLED Display
10. Battery Compartment
11. Laser Safety Cover
12. Laser/Illuminator Output Adjustment
13. Windage (not visible)/Elevation Adjustment
14. Display Light Sensor/Programming Port
15. Mode Selector Switch
16. FIRE Activation Button
17. High Power Lockout Screw





## BTAC™ NETWORKED ENABLED CAPABILITY

### SENSOR TO SHOOTER ADVANTAGE

- Providing actionable, task relevant information to and from networked teammates.
- Shot counter: Monitors shot count which is shared in real time with other users and the Armorer's Module for BlueforceCOMMAND.
- Temperature monitoring: Monitors weapon temperature and can forward based on high and low thresholds.
- Health/power: Monitors and reports maintenance flags or issues as part of the movement of shots, temperature, and location.
- Orthogonal sensor cueing allows the Wilcox MRF Xe Plugin for BTAC to communicate with other BTAC plugins allowing image capture enabled sights to pass images to BTAC Cognitive Services Plugin for identification and real-time sharing.
- Offline queue: BTAC will hold presence packets when connectivity is denied. When BTAC sees an approved network, it forwards packets cached during offline operations.
- Network friendly Selective Synchronization: Plugin may be configured to send ALL shot records, OR, only send those where shot count and/or temperature changes.

# MRF X<sub>e</sub>

## MICRO RANGE FINDER - ENHANCED LOW POWER



### OVERVIEW

The Wilcox MRF Xe™ is the next generation in the MRF line of products. As a class 3R low power laser aiming device, the MRF Xe is designed specifically for the military and law enforcement markets. The MRF Xe is a smaller, lighter, stronger laser ranging device with uncompromising performance superior to its predecessor. The built-in networking capabilities and user interface give the MRF Xe superior maintenance and replenishment connectivity with key auxiliary devices. These leading-edge features increase the warfighter's lethality and situational awareness.

Weapon and bullet information can be entered into the MRF Xe through any paired mobile device and with the application of proprietary third party software. Once the data is entered, the MRF Xe captures both the environmental conditions transmitted from the sensor suite and the distance to the target transmitted by the precision laser range finder to the onboard computer instantly providing a ballistic solution to the user.

Download technical data, additional resources and request pricing at [www.wilcoxind.com/MRF-Xe](http://www.wilcoxind.com/MRF-Xe)

IN PARTNERSHIP WITH:

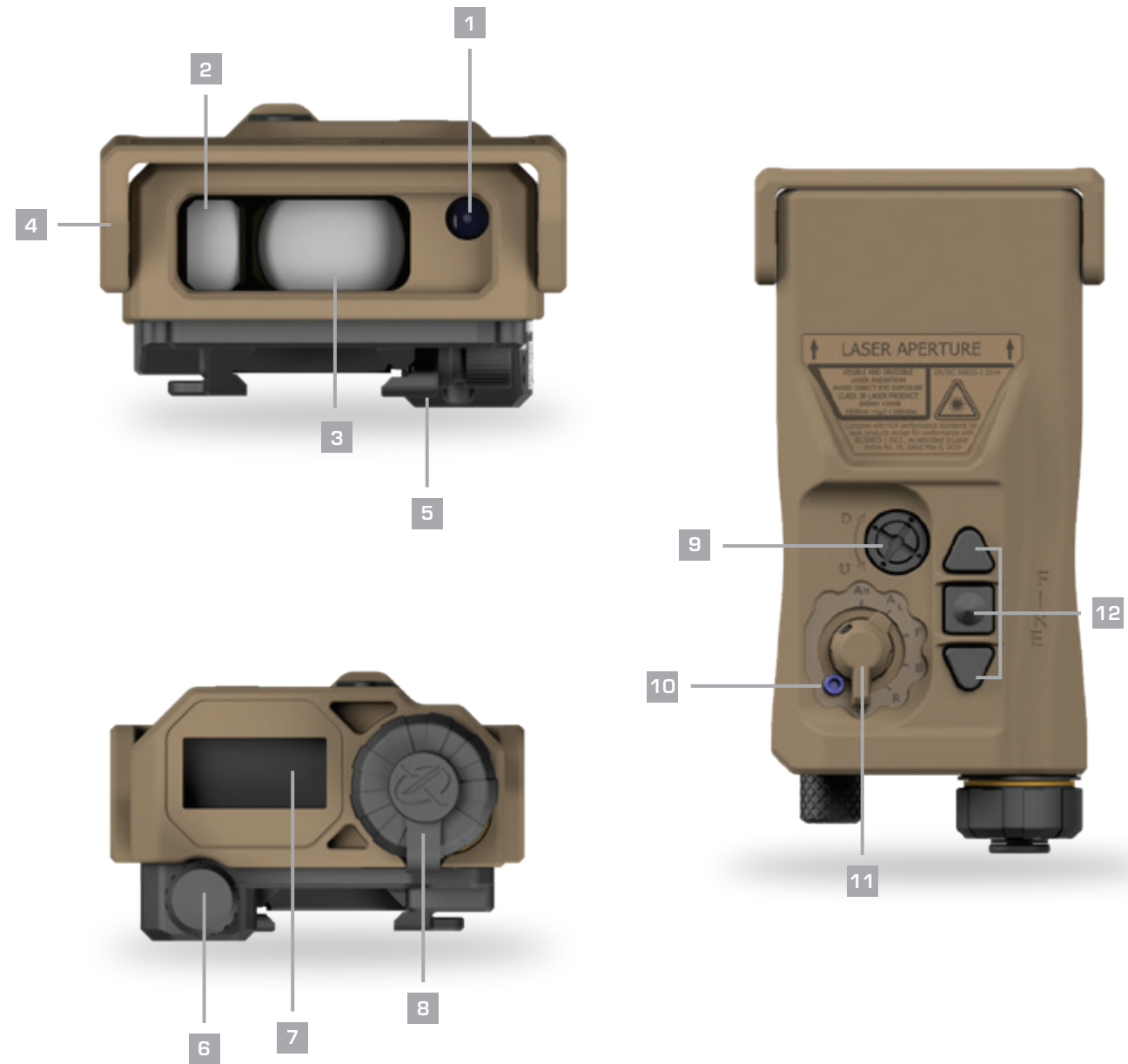

### FEATURES & BENEFITS

1. VIS Laser Pointer
2. LRF Transmitter
3. LRF Receiver
4. Laser Safety Visor
5. MIL-STD-1913 Interface
6. Remote Control Activation Pad Port
7. OLED Display/Ballistic Solver
8. Battery Compartment
9. Elevation Adjustment/Windage (not visible)
10. High Power Lockout Screw
11. Mode Selector Switch
12. Fire/Input Button





## ERGOCTO <sup>Xe</sup>

### CONTROL ACTIVATION GRIP

#### OVERVIEW

The Wilcox ERGOCTO™ Xe™ Control Activation Grip is the next generation accessory that is ergonomically positioned for the user to control Wilcox's new line of "Xe" laser and fire control devices. The ERGOCTO Xe Control Activation Grip mounts directly to the 6 o'clock rail position of the weapon with a unique grip design which allows for up to eight radial positions of the control button by the user. This feature provides an integrated control button that has an over molded skin featuring a tactile surface that helps prevent slippage of the weapon grip when controlling the device.

Download technical data, additional resources and request pricing at [www.wilcoxind.com/Xe-Grip](http://www.wilcoxind.com/Xe-Grip)

## ERGOCTO <sup>Xe</sup>

### ACTIVATION KEYPAD

#### OVERVIEW

The Wilcox ERGOCTO™ Xe™ Activation Keypad is the next generation accessory that is ergonomically positioned for the user to control Wilcox's new line of "Xe" lasers and fire control devices. The ERGOCTO Xe Activation Key Pad is mounted directly to any MIL-STD-1913 rail and can be positioned in-between the quadrant rails of most rifle handguards thereby preventing loss of the weapon grip when activating a device. The attachment mechanism of the ERGOCTO Xe Activation Key Pad features a very low-profile stance on the rail which does not interfere with the user's natural positioning of the pressure pad when handling a weapon. The ERGOCTO Xe Activation Key Pad is available in two configurations: single cable configuration that connects securely to Wilcox laser products or a dual connector cable configuration that connects to the Wilcox Laser products and the other connects to any Surefire flashlight product that has the tail-cap interface.

Download technical data, additional resources and request pricing at [www.wilcoxind.com/Xe-Keypad](http://www.wilcoxind.com/Xe-Keypad)

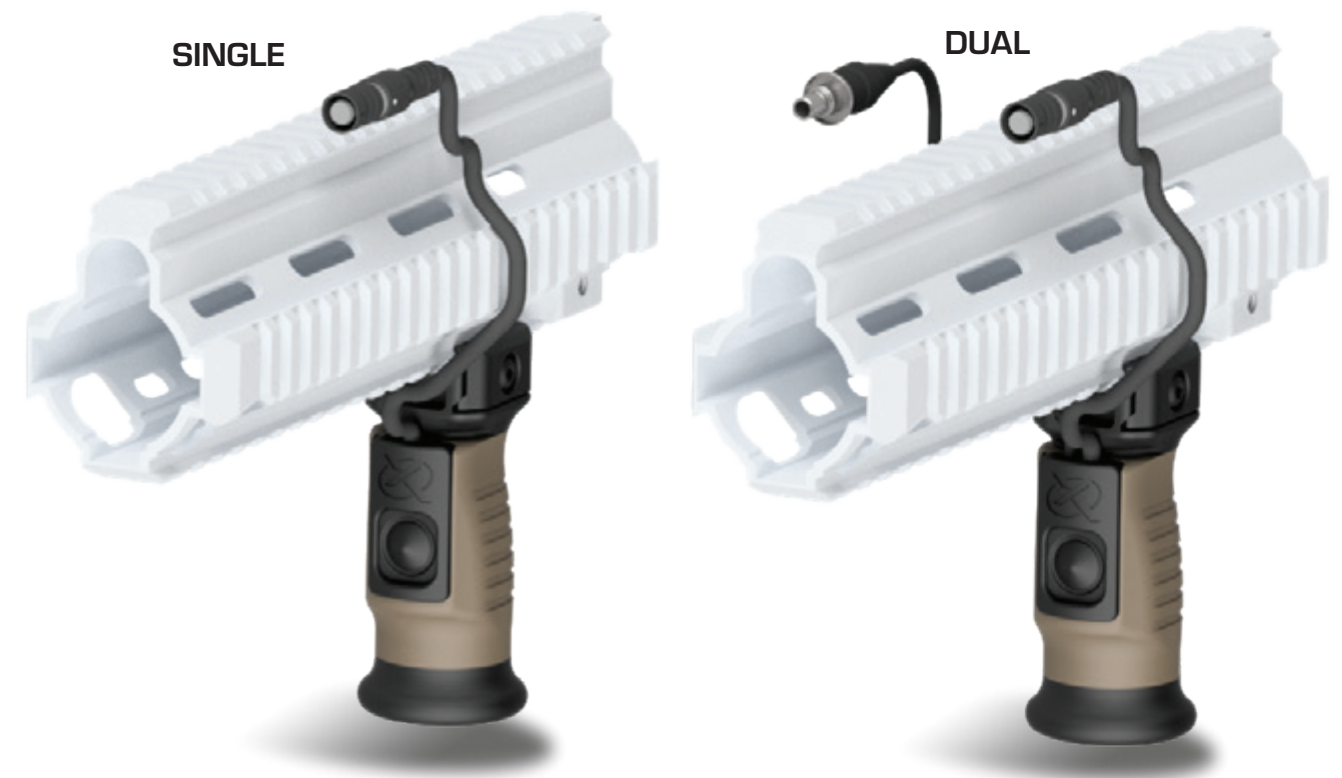

Product Illustration   -C

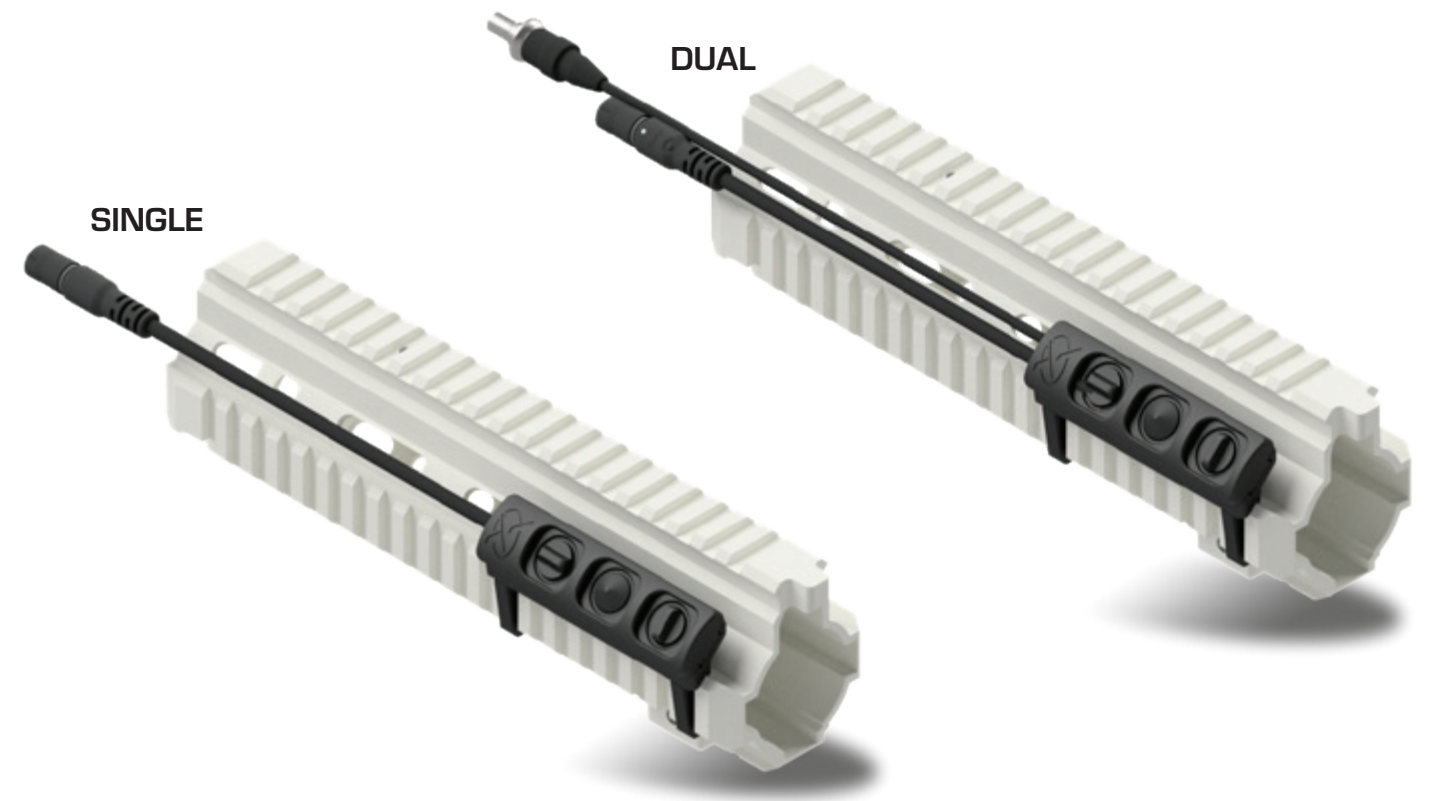



DRONE



POTENTIAL THREAT



BTAC™



### PREDICTIVE MAINTENANCE

Wilcox weapons system data can be shared in real time with Wilcox Armorer's Module, a plugable module for BlueforceCOMMAND, and the authoritative application for service and predictive maintenance.

### AUTONOMOUS REPLENISHMENT

Because BTAC and the Wilcox Plugin for BTAC are constantly monitoring weapons systems across a team, autonomous delivery platforms can be cued for just-in time field replenishment.

### FORCE READINESS

The Wilcox Armorer's Module not only drives supply chain value, but can also provide awareness of force readiness and can display weapon location and status.

### TACTICAL AWARENESS

Real-time shared awareness of oxygen and PPE operating modes, environmental data, maintenance counters, barrel temperature, and maintenance status of Wilcox devices shared in real-time amongst the team and command.

*\*Available BTAC features vary across Wilcox product lines. Contact Customer Service for additional information.*

BTAC COMMAND CENTER

WILCOX PRODUCTS



SEE BTAC IN ACTION





## GLOBAL MASTER DISTRIBUTION NETWORK

### WILCOX

UNITED STATES  
sales@wilcoxind.com



### MILLBROOK TACTICAL

CANADA  
info@millbrookcanada.ca



### AVIATION SPECIALTIES UNLIMITED

MEXICO, CENTRAL AMERICA & SOUTH AMERICA  
customerservice@asu-nvg.com



### AQUATERRO

AUSTRALIA, ASIA PACIFIC & OCEANIA  
sales@aquaterro.com



### BARZAN INDUSTRIAL GROUP

MIDDLE EAST & NORTH AFRICA  
info@barzanholdings.com



### APPLIED RESEARCH LABORATORY EUROPE

EUROPE  
info@arle.nl



### LEVEL PEAKS

UK, IRELAND & NATO SUPPORT  
web.lpa@levelpeaks.com

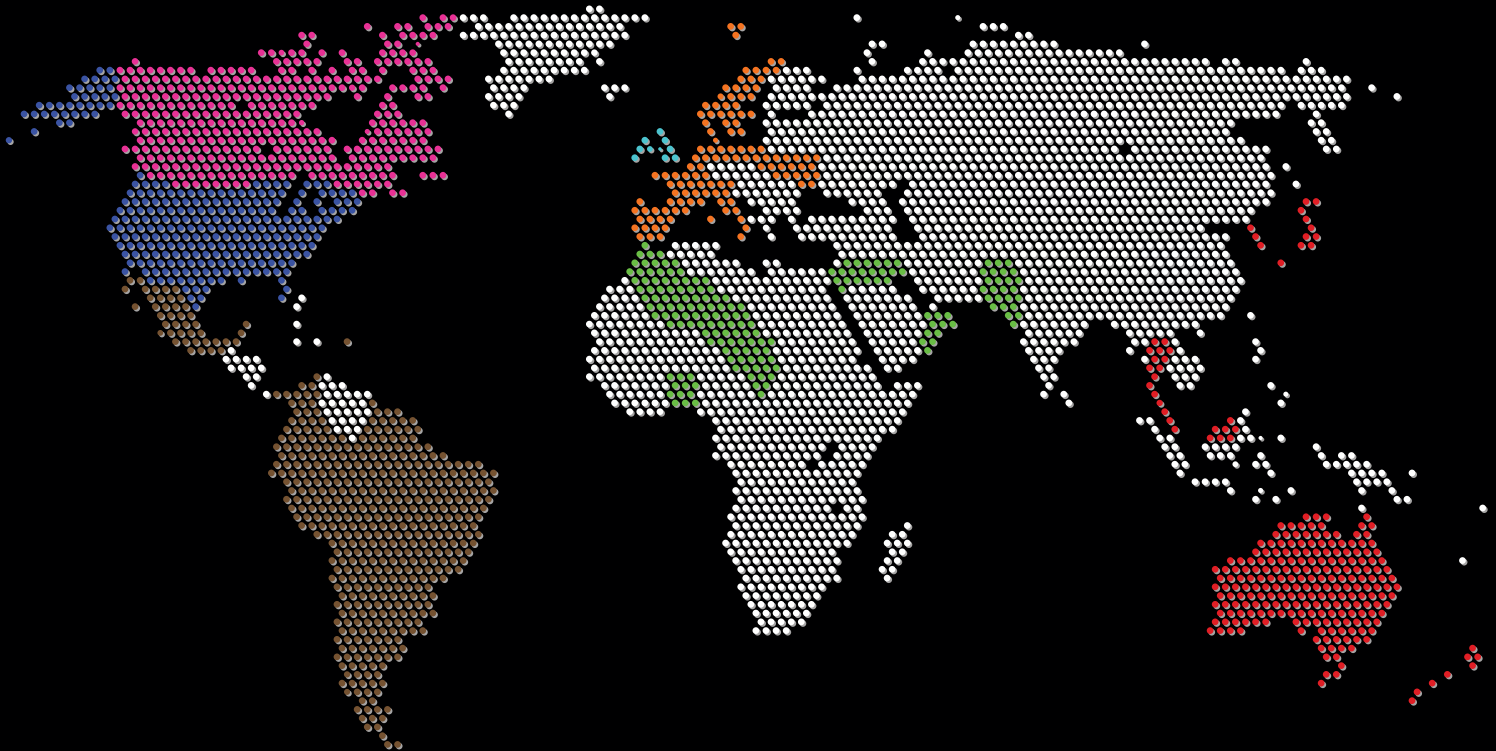

WILCOX INDUSTRIES CORP. ONE WILCOX WAY NEWINGTON, NH 03801 USA

PHONE: 603.431.1331 FAX: 603.431.1221

WWW.WILCOXIND.COM



©2021 Wilcox Industries Corp. All rights reserved. Printed in USA. U.S. and foreign patents pending. The WILCOX logo and "X" icon are Federally Registered Trademarks of Wilcox Industries Corp. BTAC is a registered trademark of Blueforce Development Corp. Wilcox RAID Xe, BOSS Xe, BOSS MXe, MRF Xe, and ERGOCTO Xe and Xe are all trademarks of Wilcox Industries Corp. Specifications subject to change without notice. Specifications subject to change without notice. All other Trademarks and Registered Trademarks are properties of their respective companies. This brochure does not constitute an offer or commitment to sell. Specifications and other data are subject to change without notice. | Technical Data regulated and restricted by the EAR, U.S. Department of Commerce license may be required for export or re-export. | Export of certain products are regulated by the U.S. Department of State and U.S. Department of Commerce in accordance with guidelines of ITAR per Title 22, Code of Federal Regulations, Parts 121-128. | U.S. Food and Drug Administration restricts the sale of high powered lasers to military and law enforcement agencies only.