

MCH QUICK START GUIDE & INSTALLATION

GENERAL OPERATION

FULL SIZE



MICRO

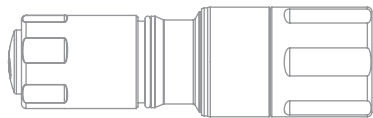

MCH is very versatile. With a variety of ND protection configurations, pocket clips and light heads, it is highly modular, flexible and even upgradeable moving forward.

Electrically, the MCH has a very unique operating system. It utilizes a direct-drive solution that results in differing amounts of performance based on the battery you choose. Some batteries will have more output than others. Some will have more run-time than others. Always use name-brand, approved batteries. See Battery Warning section for list of approved batteries.

MCH will function with both flat-top or button top, protected or unprotected rechargeable cells. Some protected cells may be too long however. Specifically, the cells with an integrated Micro USB port.

Each MCH is fitted with a push-button tail cap switch. The switch features both momentary and constant-on capability. A shallow press and hold will give you momentary. A full click will give you constant-on. Then just click to turn off.

Simple. Powerful. Configurable. Everything a handheld light should be.

NEGLIGENT DISCHARGE PROTECTION SYSTEM

SWITCHBACK



SHORT



TALL



The MCH utilizes an industry-first feature that prevents accidental or negligent discharge of the light. Each MCH ships with 3 different ND Protectors that simply thread into the tail cap. They are replaceable at any time, should you want to adjust things.

To install the ND Protector:

1. Choose the ND Protector that is right for you
2. Carefully thread it into the top of the tail cap
3. Hand-tight is all you need.
4. Installation is complete.

POCKET CLIP INSTALLATION

The MCH uses a compression fit between the light body O-ring and the pocket clip itself to secure the pocket clip to the light. Installation is simple.

1. Unscrew the tail cap and remove it.
2. Remove the smaller o-ring that is closest to the top of the light body.
3. Slide the pocket clip of choice onto the light body. Push it all the way down until it seats.
4. Place the larger included o-ring onto body above the clip.
5. Place the removed smaller o-ring back on the body where it originally was.
6. Replace the tail cap and tighten it down until it is fully-seated.
7. Installation is complete

BATTERY INSTALLATION

The battery can be installed from the front or back of the light, based on your need. As a rule, it's easier to install the battery through the front.

To install the battery:

1. Remove the head (recommended) or tail.
2. Insert the battery. Positive terminal must go towards the head.
3. Put the head or tail back on and hand-tighten.
4. Installation is complete. Enjoy your MCH.

MAINTENANCE

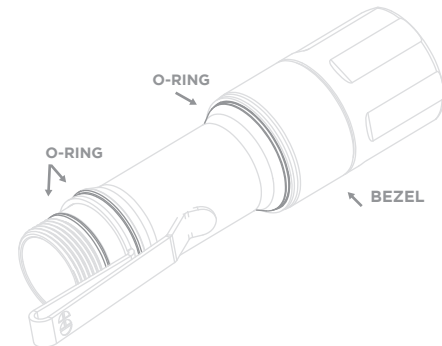

The o-rings on either side of the body: like all o-rings, can and will eventually fail. To prolong their life, periodically apply a small amount of non-petroleum based lubricant. Replacement o-rings can be purchased through www.clouddefensive.com

BATTERY WARNING

USE 18650/18350 RECHARGEABLE CELLS OR CR123A: Mission Configurable Handheld is rated for a single 18650 rechargeable battery or two CR123A batteries. MCH can use both protected and unprotected cells in both button-top and flat-top configurations. MCH Micro is rated for a single 18350 battery or single CR123A batter.

WARNING: The Mission Configurable Handheld is the most advanced handheld light available. One of those critical (but unseen) advancements is our ability to create a substantially better "heat sync". Heat sync helps the system cool. However, MCH is also very powerful. So this light will get uncomfortably hot to the touch during extremely high rates of sustained use. This is generally a non-issue for the end-user. But this light can become hot enough during certain conditions that it could trigger a "drop response".

APPROVED BATTERY MANUFACTURERS:
CLOUD DEFENSIVE / SAMSUNG / PANASONIC / LG / SANYO / SONY / KEEPOWER

LENS REPLACEMENT

Your MCH-Duty system offers the industries-only Field Serviceable Lens feature. This feature allows you unprecedented ability to maintain and replace your lens without sending your light to us for warranty. From time to time, you may need to replace the lens in your light. Muzzle blast erodes glass over time. And while our glass is far thicker than others, it is glass, and it can break with severe impact. If that happens, you can fix it yourself.

1. Confirm weapon is unloaded.
2. Remove the bezel ring by unscrewing it. Removal will take a little force to accomplish so be careful.
3. Once the bezel ring is removed, remove the o-ring that sits on top of the glass. Do not lose the o-ring.
4. Once the o-ring is removed, discard the old lens.
5. Replace the o-ring carefully. Making sure it's sitting very centered on the light head.
6. Do not touch the glass surface of the new lens. Set the glass on top of the o-ring. The owl head design self-centers the o-ring and the glass to a degree. So center the o-ring and glass as best you can and let the bezel ring do the rest.

BATTERY WARNING

Buyer has read the warnings on the product page(s) and clearly understands the potential dangers of using unprotected cell batteries. Unprotected cell batteries have more capacity and current capability than a protected cell battery. Buyer understands that unprotected cell batteries provided by Seller are only to be used in light applications manufactured by Seller. Buyer understands that use of unprotected cell batteries can result in property damage, serious bodily injury and/or death. All unprotected cell batteries can explode, catch fire, and potentially cause injuries if pierced, cut, smashed, short-circuited, burned, disassembled, recharged, dropped or used or stored in extreme temperatures. For performance purposes, the unprotected cell batteries provided by Seller do NOT contain a built-in fault or heat protection. Buyer understands unprotected cell batteries should be stored or kept in a protected casing or in the proper light application and should not be kept or stored loose in a pocket, purse, backpack or otherwise and should be kept away from metal objects to prevent short circuiting. Buyer understands when not in use, the unprotected cell batteries should ALWAYS be stored in a secure, dedicated, and non-conductive battery case. Buyer understands if an unprotected cell battery is damaged in any way, Buyer should stop using said battery immediately. Do not charge the unprotected cell battery unattended. Immediately discontinue use of the unprotected cell battery if, while using, charging or storing said battery, the unprotected cell battery emits an unusual smell, feels hot, changes color or shape, or appears abnormal in any way. Only use the unprotected cell battery charger provided by Seller to charge the unprotected cell battery. Always keep the unprotected cell batteries away from children.

CALIFORNIA PROPOSITION 65

⚠ WARNING: This product contains the following ingredients for which the State of California has found to cause cancer, birth defects or other reproductive harm, which would require warning under the statute - Lithium Nickel Manganese Cobalt Oxide, Lithium Cobalt Oxide, and others. See www.p65warnings.ca.gov for more information.

PLEASE DISPOSE BATTERIES PROPERLY



PROGRAMMING INSTRUCTIONS

Your new MCH light is now user-programmable. It ships from the factory with 5 dedicated modes to choose from. You can change the operational mode at any time. And the light will remember the mode you select even during a battery change.

Mode 1: (High-Only) 100% power

Mode 2: (Low/High) 10% power, 100% power

Mode 3: (High/Low) 100% power, 10% power

Mode 4: (Very Low/Medium/High), 5% power, 30% power, 100% power

Mode 5: (High/Medium/Very Low) 100% power, 30% power, 5% power

HOW TO ENTER CONFIGURATION MODE & CHANGE GROUPS:

NOTE: The program mode/clicks reset after the light has been on for -3 seconds and after the light has been off for -3 seconds, so it is unlikely you will ever accidentally enter configuration mode during normal use.

NOTE: Every time you enter configuration again once exited all the way out, you go back to group 1 and count up again.

1. Rapidly click the switch until the light begins to strobe to enter configuration mode. It isn't necessary to count the clicks.
2. The light will strobe briefly to let you know you have entered configuration mode.
3. Once the quick strobe stops, the light will "blink out" the number of the mode group you are going to select.
4. After the "blink out", the light will start to ramp up.
 - a. If you want to go to the next mode group, simply turn off and turn the light back on during this period.
 - b. If you want to select the mode group that was blinked out, either wait until the light ramps all the way up (configuration mode will exit) or turn the light off and wait -3 seconds.

LIFETIME WARRANTY

We warranty our stuff for life. And yes, we know these are hard-use tools. If a company in this line of work won't stand behind their stuff, you probably should not buy it. We stand immovable behind our products. MCH is no exception. There are a few things however we can not warranty on the MCH.

1. Compromised electrical system from incorrect batteries. The afore-mentioned instructions and packaging of the unit itself makes its ABUNDANTLY clear that you can ONLY use an 18650/18350 or CR123A battery. If you use a different battery, you will compromise the electrical system. So know your equipment, be smart and do NOT put any other batteries into this system. If you have questions, contact us. We're always here to help.
2. Broken lens. In the event that your MCH lens breaks, please email pictures to us at support@clouddefensive.com. We will fix or replace as needed on a case by case basis.
3. Normal wear and tear. Cosmetic damage and standard wear/tear from use comes with the turf with this kind of equipment. If you think something is excessive let us know and we'll evaluate it but we have to reserve the right to reject a warranty claim on cosmetic issues.
4. Compromised electrical system from water ingress. The MCH is waterproof and even submersible. But if you take the head or tail off the MCH and get water inside the disassembled components, the electrical system can become damaged. We can't warranty that. So just keep the MCH fully assembled when exposed to water and you'll be fine. If our seals fail and water damage is sustained because of those seals failing, we will absolutely warranty that.
5. Compromised electrical system from unauthorized disassembly of the MCH. Some parts of the MCH that are permanently sealed during the manufacturing process. If you disassemble the light head or the tailcap cartridge, your warranty is void. So basically, don't intentionally take your MCH apart beyond normal maintenance.

Simply said, big boy rules apply with the warranty. If you follow those rules, we have your back on the MCH. Forever. If you mess it up due TO NEGLIGENT operating procedures or due to unauthorized disassembly - that is on you and the warranty is void.

In the event that you void the warranty, contact us at support@clouddefensive.com and tell us what happened. We will be happy to repair your light at the lowest price possible.

CLOUD DEFENSIVE



REV02212022

WARRANTY CLAIMS

Cloud Defensive stands, unequivocally, behind its products. We will warranty this product for life with only exceptions for the above-listed user-induced issues. If our craftsmanship causes an issue, we'll fix it for life. If the unit fails under use and the warranty-voiding issues listed above are not present, we'll fix it. This is a world-class weapon light. You can expect world-class service in the event you need it.

If you need to send your MCH in for a tune-up, simply email us at support@clouddefensive.com AND identify the issue with the light. You must be issued a RMA# prior to shipping.

DISCLAIMER

Unless specified here or prohibited by applicable law, all express or implied conditions and warranties, including and without limitation, any implied warranty or condition of merchantability or fitness for a particular purpose, or accuracy of any informational content, are hereby excluded and disclaimed by Cloud Defensive LLC, and in no event will Cloud Defensive LLC be liable for any special, direct, indirect consequential, incidental or punitive damages whatsoever arising and regardless of the theory of liability, even if advised of the possibility of such damages. Products, pricing, availability, specifications and offers are subject to change or cancellation at any time, without notice.

PLEASE VISIT WWW.CLOUDDEFENSIVE.COM FOR COMPLETE TERMS & CONDITIONS

JOIN US

facebook.com/clouddefensive

youtube.com/clouddefensive

@clouddefensive

We love seeing your pictures on social media. Please tag us on Instagram.

SUPPORT

support@clouddefensive.com
Cloud Defensive
6045 Wedeking Avenue Unit E

Evansville, IN 47715

www.clouddefensive.com