

# M

## M-LOK<sup>®</sup>

M-LOK is a modular locking accessory mounting system that is a direct attachment method for hard mounting accessories to a negative space mounting point. Designed by Magpul Industries as an evolution of the MOE<sup>®</sup> slot system used since 2007, the M-LOK system is being released as a free licensed platform to allow greater compatibility of accessories between all manufacturers.



# HISTORY

In late 2007 Magpul Industries Corp developed the Masada Concept Rifle that featured a polymer hand guard with three elongated vent holes that acted as a negative mounting surface for accessory rails.



*ORIGINAL MAGPUL MASADA PROTOTYPE 2007*

These slots became one of the first “negative space” attachment systems that allowed the user to put mounting rails only where they were needed, as opposed to covering the entire surface with mounting rails, which are then covered with panels. The system also allowed direct mounting of accessories, such as fore-grips and flashlights, with no rail interface needed.

In 2009 the MOE hand guards for the common AR15/M16 firearms were released, bringing the same slot system, along with rails, flash light mounts, grips and other accessories to the mainstream.

In the years since the MOE slot system has been released, several million MOE slot compatible accessories have been produced. Initially introduced as a Magpul-specific system, several other companies have built MOE slot compatible accessories in the years since its release.

The MOE system was never officially released as an open standard, and the requirement to have access to the back side of the mounting surface limited its application. Additionally, depending on the accessory item, the spacing increments were not always small or uniform enough for desired placement. These characteristics made MOE slots and accessories less ideal to use with free-float hand guards, which did not allow back side access to the mounting surface. Rather than documenting and publishing the existing MOE slot information and weld nut system, Magpul engineers used this opportunity to substantially improve the feature set of the MOE system. The result is the M-LOK.

# M-LOK

M-LOK stands for Modular Lock system. The M-LOK system retains an elongated slot appearance, similar to MOE slots (with different dimensions). The new slot is larger, has squared sides, and the new system adds the following feature set:

- DIRECT MOUNT CAPABILITY
- CAMMED T-NUT
- OPTIMIZED FOR METAL AND POLYMER MANUFACTURING
- RECOIL/IMPACT MITIGATION LUGS
- INTERMEDIATE SPACING OPTION
- MULTI-DIRECTIONAL MOUNTING
- BACKWARDS MOE COMPATIBILITY



# FEATURES

## DIRECT MOUNT CAPABILITY

Accessories are mountable directly from the front face of the slot. No access from the rear of the system is needed.

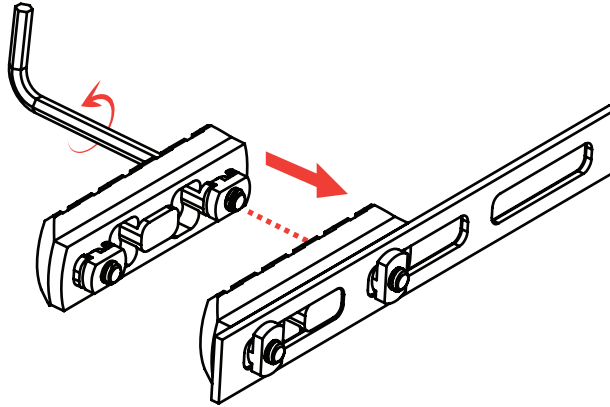

## CAMMED T-NUT

The M-LOK direct attachment system features a custom, cammed T-Nut that positions the T-Nut consistently for installation and removal. Simply adjust the gap between the T-Nut and accessory to match the thickness of the mounting surface, align the T-Nuts with the slot, and insert in the desired location. An initial  $\frac{1}{4}$  to  $\frac{1}{2}$  turn of the screw for each T-Nut rotates the nut into engagement and then you may tighten normally.

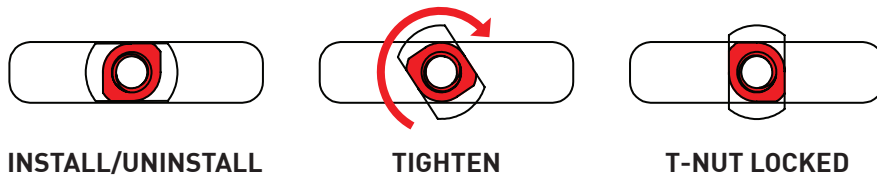

## OPTIMIZED FOR METAL AND POLYMER MANUFACTURING

Simple, rounded, rectangular slots with no sharp edges, complex geometry, or undercuts make the M-LOK slots optimal for high volume metal and polymer manufacturing.

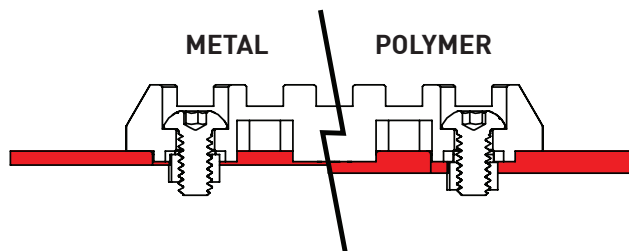

The M-LOK slots require no special cutters or angle gauges in the manufacturing process. With injection molding, the lack of an undercut allows simple mold design. All of this results in the lowest manufacturing costs possible.

**RECOIL/IMPACT MITIGATION LUGS**

Accessories feature recoil mitigation lugs with full recoil lug support in all 4 axes of movement, preventing movement of the system under recoil or rough handling, allowing repeatable accuracy in removal and reinstallation.

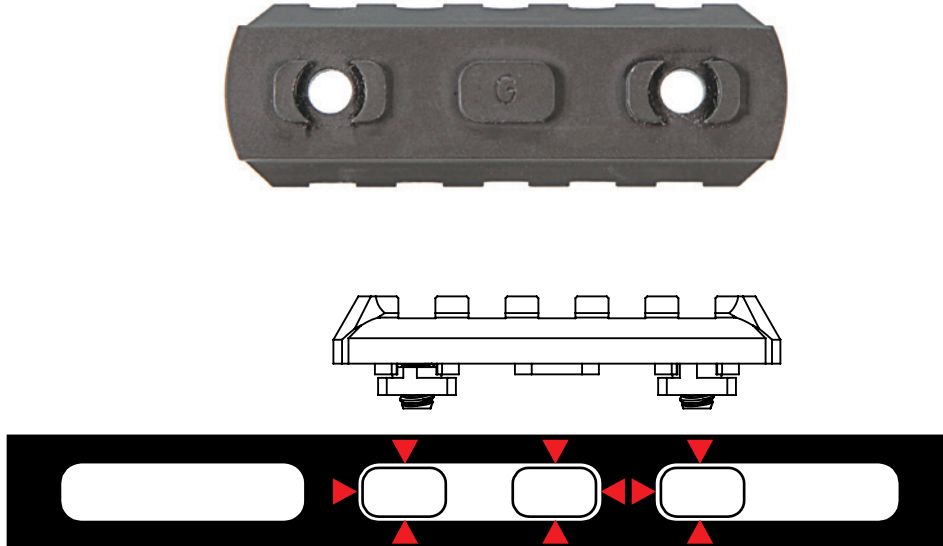

**INTERMEDIATE SPACING OPTION**

M-LOK accessories can be direct mounted entirely within a slot or bridging between/ across slots, making the adjustment interval smaller than the size of a single slot. (Intervals equal two Picatinny rail slots (20mm) of adjustment). Full, 4 axis recoil lug support is maintained at every interval.

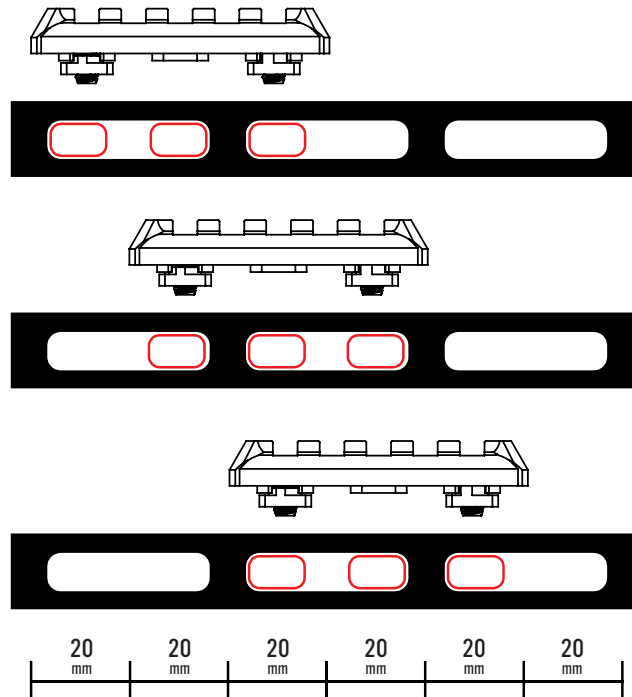

**MULTI-DIRECTIONAL MOUNTING**

Accessories can be mounted facing toward the front or the rear (180 degrees difference), with full recoil lug support—the system does not need to be oriented in a specific direction to function properly.

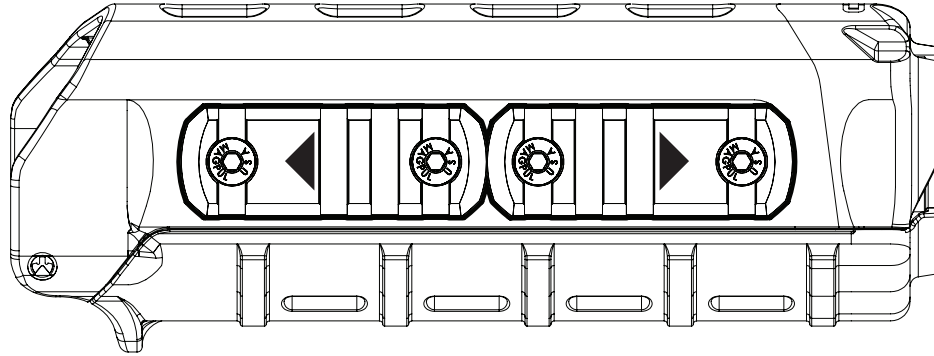

*IDENTICAL M-LOK ACCESSORIES SHOWN MOUNTED IN SLOT ORIENTED FORWARD FACING AND REAR FACING.*

**NOTE:** *M-LOK accessories will also fit with the MOE slots with an adapter plate (not shown) available from Magpul.*

# IMPLEMENTATION

Magpul Industries and several other manufactures will rapidly phase in the M-LOK system during 2014 following this basic timeline.

- M-LOK will immediately replace MOE slots on all new products introduced by Magpul Industries. The first of these will be the new MOE SL shown at the 2014 NRA Annual Meeting and Exhibits April 25th-27th.
- All current Magpul items featuring the MOE slot system will be systematically converted to the M-LOK standard during 2014. Both MOE and M-LOK versions of accessories will be offered concurrently for at least 18 months before MOE accessories are phased out. All existing MOE AR15 hand guards and shotgun forends will be redesigned to use the new M-LOK in 2014.
- A complete line of dedicated M-LOK direct-attachment accessory items will be offered, with a large complement of dedicated accessories shipping by the fall of 2014, and some accessories available when the system is introduced. This will include several sizes of Picatinny rails, slot covers, foregrips, angled foregrips, sling mounts and various light mount options.
- The M-LOK system will have priority for all new accessories from Magpul, although some new items may be offered for the MOE system as well.

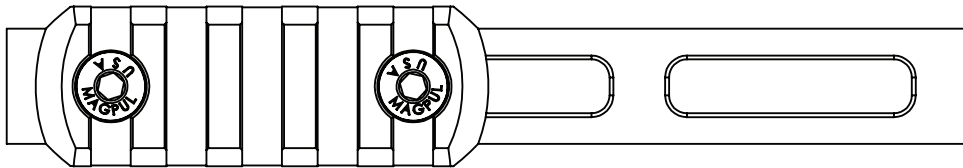

# FAQs

**Q: Is the M-LOK design free for any manufacturer to use?**

**A:** Yes, there is no fee to use the M-LOK design, however we do ask that manufacturers sign a simple no-fee license form before using the M-LOK system and logo on their products and media.

**Q: Why is a licensing agreement required instead of releasing the system “open-source”?**

**A:** By licensing the system for free, the same no-cost access to the system is provided as with an open-source release. However, this method protects both manufacturers and consumers by assuring that all products bearing the M-LOK logo are made to proper specifications and will work with all other M-LOK products, preventing problems with compatibility and inaccurate or counterfeit versions of M-LOK products.

**Q: I see the basic M-LOK slot dimensions are available on the web. Where are the dimensions for the M-LOK T-Nut?**

**A:** The M-LOK T-Nut is currently under review by the US State Dept to determine its ITAR classification. Until then, dimensioned drawings of the nut will be restricted to verified US citizens, but are available free to all qualified recipients. Complete, finished T-Nuts are also available for purchase directly from Magpul. For further details or to request drawings please contact Drake Clark: [dclark@magpul.com](mailto:dclark@magpul.com).

**Q: What is ITAR?**

**A:** The International Traffic in Arms Regulations (ITAR) is a set of United States government regulations that control the export and import of defense-related articles and services on the United States Munitions List (USML).

**Q: Why the M-LOK system and not another existing open source system such as KeyMod?**

**A:** In our experience, KeyMod is not a suitable mounting system for polymer products, because a conical nut is used to secure the accessory in place. On plastic materials, the conical mating surfaces of KeyMod will either promote cracking or loosening due to creep and deformation of the material.

In addition, KeyMod’s undercut also requires the use of specialized cutters for CNC operations or complex injection mold designs. As a result of the KeyMod design, the QC process becomes significant with high volume manufacturing, resulting in increased time and cost when compared to manufacturing the M-LOK system.

**Q: Will all M-LOK accessories be cross compatible with all other M-LOK platforms?**

**A:** M-LOK is an extremely versatile system, and we want everyone who adopts the system to have the freedom to make the best use of it with their products. In order to maximize compatibility, Magpul will publish drawings that include “Recommended Manufacturing Practices”. Adhering to these standards of backside clearance, material thicknesses, accessory profile, etc., will maximize compatibility with all Magpul accessories and with all other accessories built within these guidelines.

**Q: What is the return to zero on the M-LOK System?**

**A:** With biasing of the accessory, similar to biasing a Picatinny rail optic mount, M-LOK return to zero is equivalent to Picatinny rail mounting interfaces.



**Q: Is the M-LOK design patented?**

**A:** The M-LOK system is patent pending, however, this is only to protect against similar systems and counterfeits causing incompatibility and confusion in the marketplace. The system will remain free and open for all to use, providing items are built within the published standards.

**Q: How can I tell the difference between the original MOE slots and the new M-LOK?**

**A:** The M-LOK slots are noticeably taller (7mm tall) than the MOE, and has flat ends, as opposed to the MOE's pill shaped slot.

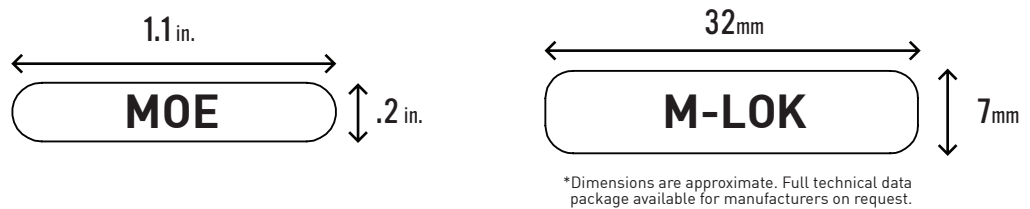

In addition, the M-LOK logo may be present to indicate that the slot is made to M-LOK specifications.

**Q: What does the M-LOK logo look like?**



**Q: How does the M-LOK T-Nut work exactly?**

**A:** The M-LOK T-Nut has a cammed shank. The T-Nut is aligned with the slot for installation.

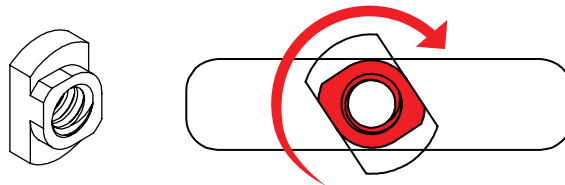

Once placed on the rail, the T-nut rotates 90 degrees across the slot and is then stopped by the cammed shank as the bolt is tightened. When removing, as the installation bolt is loosened, the cammed shank allows the T-Nut to turn back 90 degrees and stop, to be parallel to the slot for easy removal.

**Q: How secure is the M-LOK T-Nut?**

**A:** The engagement surface area and the strength of all hardware has been tested in live fire, shock, drop, vibration under heat cycle, and direct force pull out in excess of 300 lbs with no loosening of the system.

**Q: Do I have to buy the special M-LOK T-Nut from Magpul?**

**A:** No, the T-Nut can easily be machined per the drawing. T-Nuts will be available directly from Magpul for retail or bulk purchases. Retail price for these will be under \$1.75 each, with substantial quantity discounts/OEM pricing for manufacturers.

**Q: T-Nuts aren't rotating correctly and stopping at 90 degrees! How do I fix this?**

**A:** The versatility of M-LOK does require you to position the nut on the mounting screw at least reasonably close to the right depth for the thickness of the material you are attaching to. Simply adjust the T-Nut on the screw for trouble-free correct installation.

**Q: Are the M-LOK nuts captured on the screw?**

**A:** Manufacturers have the option to capture the nut onto the bolt or not. Staking the nuts within our recommended manufacturing guidelines may provide a more trouble-free installation and removal, but can drive up costs and limit hardware replacement options. Not staking them allows the user to replace damaged hardware or adapt accessories to custom applications, and is still very easy to use. We provide information on both options to all manufacturers.

**Q: I have a hand guard with the original MOE slots. Can I use the new M-LOK accessories on it?**

**A:** Yes, M-LOK accessories will fit with the MOE slots with an adapter plate available from Magpul. M-LOK accessories, however, will have to utilize the existing MOE attachment bolt and nut.

**Q: Was M-LOK developed in conjunction with any government or private entity outside of Magpul?**

**A:** No, the entire M-LOK system was developed in house at Magpul using no public or external private funding, and vetted by industry partners prior to public release.

**Q: Is the M-LOK system suitable for use in non firearms applications?**

**A:** Yes, while M-LOK was designed specifically for firearms accessories mounting, the design can be adapted to helmet, vehicle, and other applications (within tech specifications), and could potentially be scaled for even larger applications.

# ABOUT MAGPUL

Founded in 1999, Magpul began with a passion for design and the idea for an innovative device to aid in reloading magazine-fed rifles under stress. The company's name comes from the original product, called the Magpul. Over the last decade, Magpul has continued grow through a dedicated focus on its foundational principles of innovation, value, creativity, and mission-focused efficiency.

Further information can be found at [www.magpul.com/foundations](http://www.magpul.com/foundations)