

Wired Zone Expander Module

INSTALLATION AND SETUP GUIDE

GENERAL INFORMATION

This module adds up to eight end-of-line resistor supervised zones to compatible control/communicators via the control's keypad wiring.

The module may be mounted within the control's cabinet (if room permits), or remotely. If mounted remotely, there are provisions to tamper protect the unit. Communication to the module is supervised so that it cannot be disconnected from the keypad wiring without detection by the control. If the wiring is cut, a tamper alarm or signal will result, to indicate that this device (and possibly other similarly connected devices) has become inoperative.

INSTALLATION

	<ol style="list-style-type: none"> 1. Power should be disconnected before proceeding. 2. Be sure to mount the 4219 before making any wire connections.
---	--

When the module is mounted remotely, holes on the back of the module's housing permit it to be mounted horizontally or vertically. Wires can exit from the side or the breakout on the back of its housing. For tamper protection, attach the tamper magnet (provided) (Figure 1) to the module inside cover. Place the tamper jumper (Figure 2) into its lower position. Affix the connections label that accompanies the module to the inside of the module's cover. When the installation is complete, put the module's cover on. The magnet attached to the cover, positioned near the reed switch, will cause a tamper signal to be sent to the control if the cover is removed.

When the module is to be mounted inside the control's cabinet, mount it horizontally to the raised tabs at the back of the cabinet. Insert self-tapping screws (provided) in two adjacent raised tabs at the back of the cabinet. Leave the heads projecting 1/8". Hang the module on the screw heads via two slotted holes on the back of the module's housing. When the module is installed in the control's cabinet, it need not be tamper protected. Place the tamper jumper (Figure 2) in the upper position. Affix the connections label that accompanies the module to the inside of the control's cover.

See the control's installation and setup guide for additional information.

CONNECTIONS AND SETTINGS

Make protection zone connections to the module's 12-position terminal block TB1. Each zone that is used must have a 1000-ohm end-of-line resistor connected across the end of its loop, as shown in Figure 1.

CE	<p>For CE installations ADEMCO N6361 EMI suppression bead is required. Refer to the N6361 installation guide for wire routing instructions.</p>
-----------	--

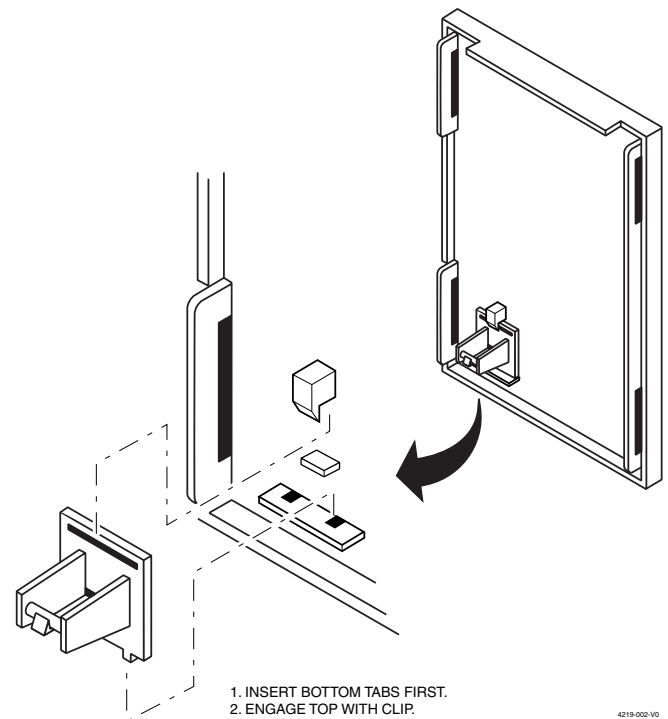

Figure 1. Tamper Magnet Installation

If a zone is not programmed, the resistor need not be used. The method of programming each zone for the type of alarm and reporting code to the central monitoring station varies with the control to which the module is connected. Refer to the Installation and Setup Guide for that control unit.

Set the DIP Switch to one of 16 addresses, as shown in Figure 3, so the control can identify the module and communicate with it properly. The address to be set is determined by the particular control to be used, and the control's installation instructions must be consulted. As shipped, the DIP Switch is set for an address of "0".

Zone A can be set for fast response time of 10ms to an open circuit, if desired, by setting position 1 of the DIP Switch to "OFF". As shipped, it is set to "ON" for a response time of 300ms, as shown in the table below. All of the module's other protection zones have a nominal response time of 300ms.

Connections to the control's keypad wiring points can be made via 4-terminal block TB2 or the 4-pin plug (wire color connections are the same).

SPECIFICATIONS

Physical	6-7/16"W x 4-1/4"H x 1-1/4" D (163mm x 108mm x 32mm)
Electrical	
Input Voltage:	12VDC (from control's remote keypad connection points)
Current:	30mA

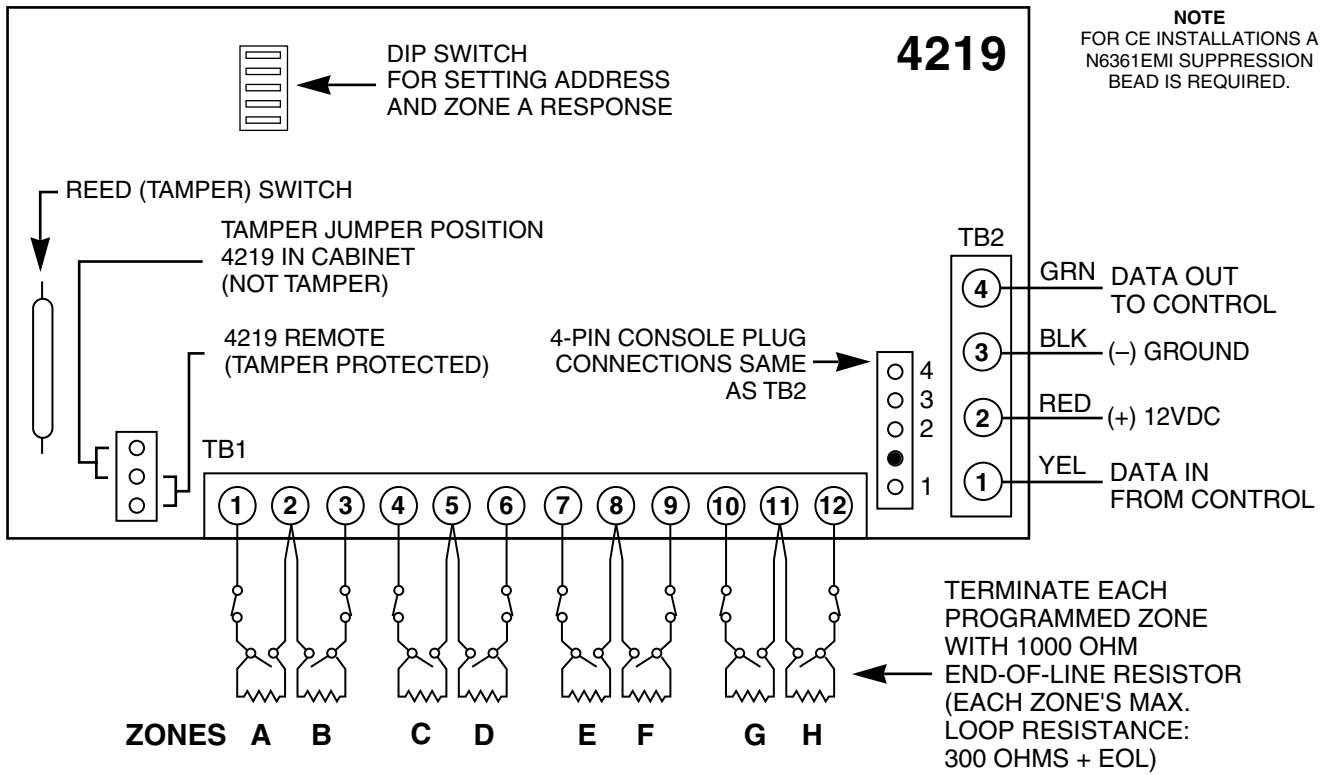

Figure 2. Summary of Connections

4219-SOC-V0

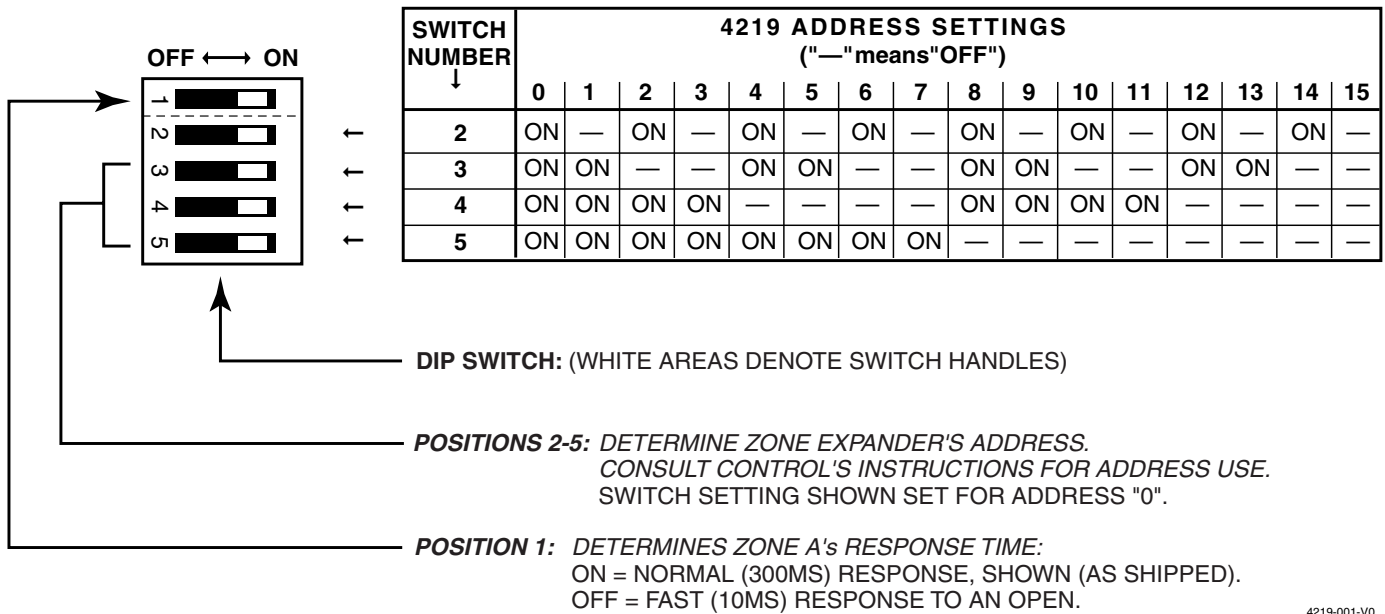

Figure 3. DIP Switch Settings

4219-001-V0

SEE THE CONTROL PANEL'S INSTALLATION AND SETUP GUIDE FOR COMPLETE INFORMATION REGARDING THE LIMITATIONS OF THE ENTIRE SECURITY SYSTEM.

LIMITED WARRANTY

Honeywell International Inc., 165 Eileen Way, Syosset, New York 11791, warrants its product(s) to be in conformance with its own plans and specifications and to be free from defects in materials and workmanship under normal use and service for 24 months from the date stamp control on the product(s) or, for product(s) not having a date stamp, for 12 months from date of original purchase unless the installation instructions or catalog sets forth a shorter period, in which case the shorter period shall apply. Seller's obligation shall be limited to repairing or replacing, at its option, free of charge for materials or labor, any product(s) which is proved not in compliance with Seller's specifications or proves defective in materials or workmanship under normal use and service. Seller shall have no obligation under this Limited Warranty or otherwise if the product(s) is altered or improperly repaired or serviced by anyone other than Honeywell factory service. For warranty service, return product(s) transportation prepaid, to Honeywell Factory Service, 165 Eileen Way, Syosset, New York 11791.

THERE ARE NO WARRANTIES, EXPRESS OR IMPLIED, OF MERCHANTABILITY, OR FITNESS FOR A PARTICULAR PURPOSE OR OTHERWISE, WHICH EXTEND BEYOND THE DESCRIPTION ON THE FACE HEREOF. IN NO CASE SHALL SELLER BE LIABLE TO ANYONE FOR ANY CONSEQUENTIAL OR INCIDENTAL DAMAGES FOR BREACH OF THIS OR ANY OTHER WARRANTY, EXPRESS OR IMPLIED, OR UPON ANY OTHER BASIS OF LIABILITY WHATSOEVER, EVEN IF THE LOSS OR DAMAGE IS CAUSED BY THE SELLER'S OWN NEGLIGENCE OR FAULT.

Seller does not represent that the product(s) it sells may not be compromised or circumvented; that the product(s) will prevent any personal injury or property loss by burglary, robbery, fire or otherwise; or that the product(s) will in all cases provide adequate warning or protection. Customer understands that a properly installed and maintained alarm system may only reduce the risk of a burglary, robbery, fire, or other events occurring without providing an alarm, but it is not insurance or a guarantee that such will not occur or that there will be no personal injury or property loss as a result. CONSEQUENTLY, SELLER SHALL HAVE NO LIABILITY FOR ANY PERSONAL INJURY, PROPERTY DAMAGE OR OTHER LOSS BASED ON A CLAIM THAT THE PRODUCT(S) FAILED TO GIVE WARNING. HOWEVER, IF SELLER IS HELD LIABLE, WHETHER DIRECTLY OR INDIRECTLY, FOR ANY LOSS OR DAMAGE ARISING UNDER THIS LIMITED WARRANTY OR OTHERWISE, REGARDLESS OF CAUSE OR ORIGIN, SELLER'S MAXIMUM LIABILITY SHALL NOT IN ANY CASE EXCEED THE PURCHASE PRICE OF THE PRODUCT(S), WHICH SHALL BE THE COMPLETE AND EXCLUSIVE REMEDY AGAINST SELLER.

This warranty replaces any previous warranties and is the only warranty made by Seller on this product(s). No increase or alteration, written or verbal, of the obligations of this Limited Warranty is authorized.

FEDERAL COMMUNICATIONS COMMISSION (FCC) Part 15 STATEMENT

This equipment has been tested to FCC requirements and has been found acceptable for use. The FCC requires the following statement for your information:

This equipment generates and uses radio frequency energy and if not installed and used properly, that is, in strict accordance with the manufacture's instructions, may cause interference to radio and television reception. It has been type tested and found to comply with the limits for Class B computing device in accordance with the specifications in Part 15 of FCC Rules, which are designed to provide reasonable protection against such interference in a residential installation. However, there is no guarantee that interference will not occur in a particular installation. If this equipment does cause interference to radio or television reception, which can be determined by turning the equipment off and on, the user is encouraged to try to correct the interference by one or more of the following measures:

- If using an indoor antenna, have a quality outdoor antenna installed.
- Reorient the receiving antenna until interference is reduced or eliminated.
- Move the radio or television receiver away from the receiver/control.
- Move the antenna leads away from any wire runs to the receiver/control.
- Plug the receiver/control into a different outlet so that it and the radio or television receiver are on different branch circuits.

If necessary, the user should consult the dealer or an experienced radio/television technician for additional suggestions. The user or master may find the following booklet prepared by the Federal Communications Commission helpful:

"Interference Handbook"

This booklet is available from the U.S. Government Printing Office, Washington, DC 20402.

The user shall not make any changes or modifications to the equipment unless authorized by the Installation Instructions or User's Manual. Unauthorized changes or modifications could void the user's authority to operate the equipment.

Honeywell

165 Eileen Way, Syosset, NY 11791
Copyright © 2004 Honeywell International Inc.

www.honeywell.com/security



N8924V1 5/01 Rev. B