



SEM210 QUICK INSTALL GUIDE

SIMPLIFIED INSTRUCTIONS FROM YOUR FRIENDLY A.S.S. TEAM MEMBERS

We have compiled a much simpler installation manual for our customers in the hopes that we can alleviate all complications while installing your SEM210. Following this instruction guide will give you the best chance at setting up your Alarm.com communicator without ever having to reach out for any assistance. If you do have any problems or questions though, please feel free to email us at alarms@alarmssystemstore.com and we will do our best to assist you.

STEP GUIDE:

1. PURCHASE ALARM.COM SERVICE AND FILL OUT REQUIRED FORMS
2. DISARM THE PANEL AND POWER DOWN
3. WIRE THE SEM TO THE PANEL
4. POWER THE SYSTEM UP AND ALLOW THE SEM TO SYNC TO THE PANEL
5. BROADCAST YOUR ZONE LABELS
6. SEND A SYSTEM TEST SIGNAL
7. ENJOY YOUR NEW ALARM.COM INTERACTIVE SERVICE

TO SEE A VIDEO TUTORIAL OF THIS INSTALLATION
PROCESS, SCAN THE QR CODE HERE:

STEP 1: BEFORE YOU START

1. **PURCHASE AN ALARM.COM INTERACTIVE SERVICE FROM ALARM SYSTEM STORE AND COMPLETE THE INSTRUCTIONS IN THE ACTIVATION EMAIL.**
2. **ENSURE YOU HAVE ALL OF THE COMPONENTS NEEDED FOR YOUR SEM210 INSTALLATION:**

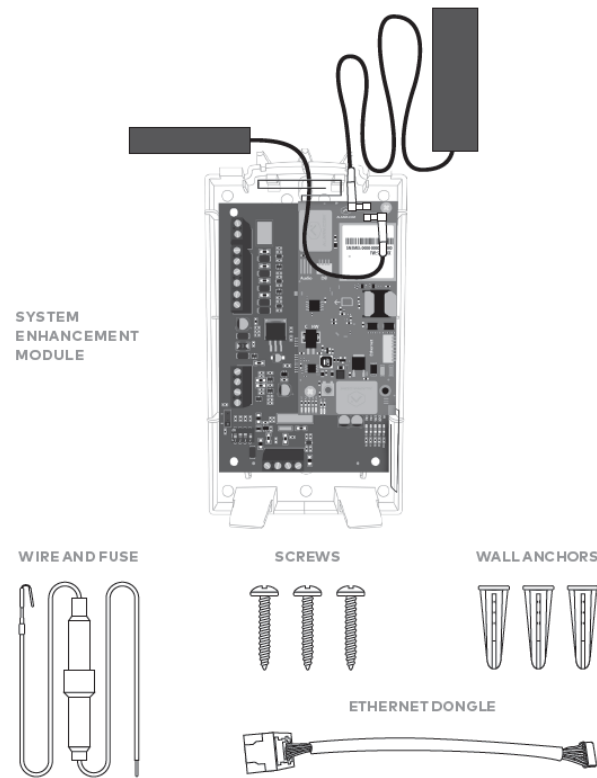

STEP 2: DISARM THE SYSTEM AND POWER DOWN

DISARM AND POWER DOWN THE PANEL

1. Verify the panel is disarmed and clear of any alarms, troubles, or system faults.
2. If you do not know the current installer code, check the installer code at the panel before powering down the panel.
3. Then remove AC power and disconnect the backup battery to completely power down the system.

STEP 3: CONNECTING THE SEM

WIRING

Important: If you do not know what this means, disregard this sentence. Alternate wiring is required when using this device for ETL installations. (+12v wire from the SEM will go to the +12V terminal on the panel)

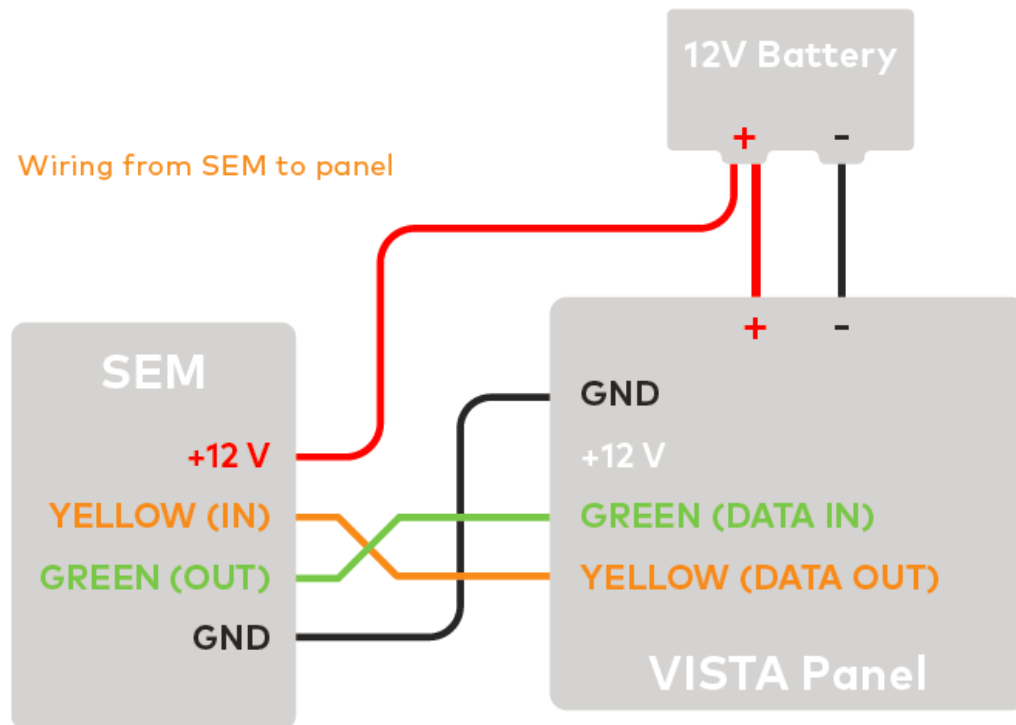

TO WIRE THE PANEL:

1. Connect panel terminal 4 (GND) to SEM GND, panel terminal 6 (GREEN: DATA IN FROM KEYPAD) to GREEN (OUT), and panel terminal 7 (YELLOW: KEYPAD DATA OUT) to YELLOW (IN).
2. Using the included red cable with the two-prong battery connector, connect the battery to both the SEM and the panel. For a power limited circuit, ensure the fuse is inside the Vista panel.
3. Connect an Ethernet cable to the optional Ethernet dongle to utilize Dual-Path communication. Local network changes may be required before the broadband path activates.
4. Remove the snap-off plastics from the enclosure side at the desired locations, then route the cables around the internal strain relief walls and out the side of the enclosure.
5. Before completing the mounting, verify the wiring connections are secure and all internal components are in their proper location.
6. Then close the enclosure by sliding the cover into the mounting points at the top of the enclosure base and then swinging down the cover to snap the thumb tabs into place.

STEP 4: POWER THE SYSTEM UP AND ALLOW THE SEM TO SYNC WITH THE PANEL

Connect the backup battery and restore AC power to the panel. For the SEM to interact with the existing zones on the system, it must read them from the PowerSeries panel. The SEM does a zone scan to read this information.

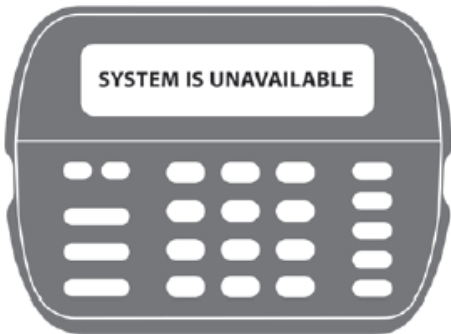

ZONE SCAN

~10 minutes

Do not touch the panel or keypad.

The zone scan automatically begins within one minute after the panel is powered up and should take between 5 and 15 minutes, depending on the number of partitions and zones on the system. Do not touch the panel, keypad, or SEM, at this time.

The zone scan is complete when the green and yellow lights on the keypad remain solid. If you press any buttons on the keypad during the zone scan, the message *System unavailable* displays on the screen. The date and time shows on the screen when the zone scan is complete.

Important: If the system was previously communicating over a phone line, we recommend Disabling Telco Line Monitoring (Section 015, Option 7) and Removing the Phone Numbers (Section 301-303).

STEP 5: BROADCAST ZONE LABELS

For the SEM to be able to read the sensor names stored on the panel and display them on Alarm.com, you must broadcast the sensor names stored on the keypads. This should be done for every install with an LCD keypad and is necessary even if there is only one keypad on the system.

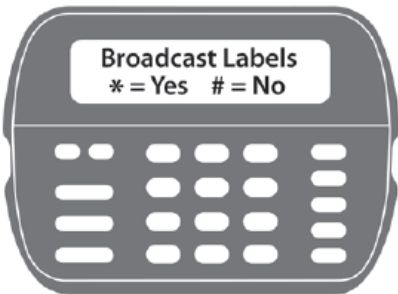

Broadcast sensor names by selecting the following:

[*] + [8] + [Installer Code] + [*]
to enter LCD programming.

From LCD programming, go to field 998 and press [*] to broadcast sensor names.

STEP 6: SEND A SYSTEM TEST

After you have installed your SEM210, email alarms@alarmsystemstore.com your IMEI number from the communicator along with your order number. They will give you instructions for completing your system test and set up your Alarm.com account. You will also receive a "Get Started" email. Leave this email as is until the following steps are completed.

SYSTEM TEST:

To fully activate your service and sync up the panel and communicator to the Alarm.com account, you will need to send a system test from the panel. To do this follow these steps:

- Press *6 + (master code if required)
- Using the > button, scroll right to option 4 (system test)
- Press *
- The siren will sound for a moment, and the system will send a signal for the test.

After you have run the system test email alarms@alarmsystemstore.com to confirm signal transfer. If they received your signal, you may now follow the "Get Started" link from the email mentioned above.

IF YOU HAVE A CENTRAL STATION ACCOUNT YOU ARE ACTIVATING AS WELL, YOU MAY NOW PROCEED WITH THE ACTIVATION AND TESTING FOR IT. OUR CUSTOMER SERVICE (alarms@alarmssystemstore.com) WILL INFORM YOU ON HOW TO TEST YOUR SYSTEM AND FINISH YOUR ACTIVATION.

**CONGRATULATIONS! YOU HAVE JUST
INSTALLED YOUR SEM210!
YOU ARE READY FOR STEP 7: ENJOY
YOUR ALARM.COM INTERACTIVE PLAN**