

DOIT **BONAPACE**

PHARMACEUTICAL & LAB EQUIPMENT SINCE 1946

CAPSULES

AUTOMATIC AND SEMI-AUTOMATIC
BENCH TOP CAPSULE FILLING MACHINES
FOR POWDERS WITH TAMPING
AND DOSATOR SYSTEM, PELLETS,
TABLETS, MINI-TABLETS,
CAPSULE IN CAPSULE AND LIQUIDS

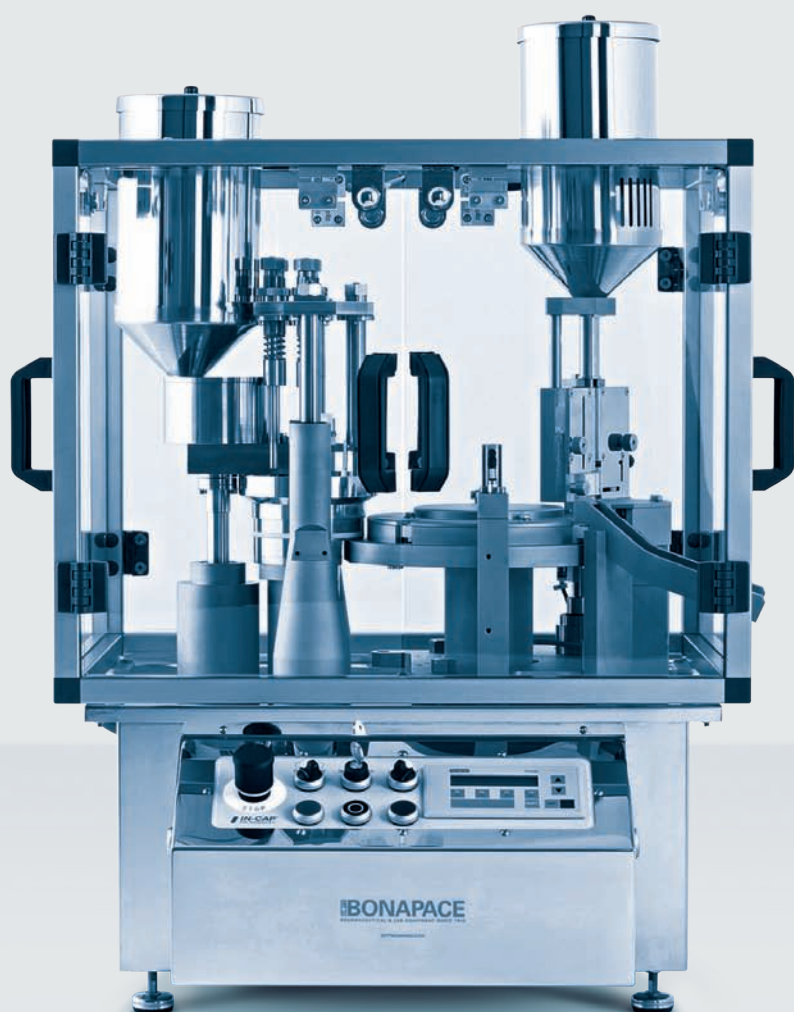
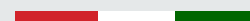

AUTOMATIC

IN-CAP

The original - bench top - capsule filler,
fully automatic.

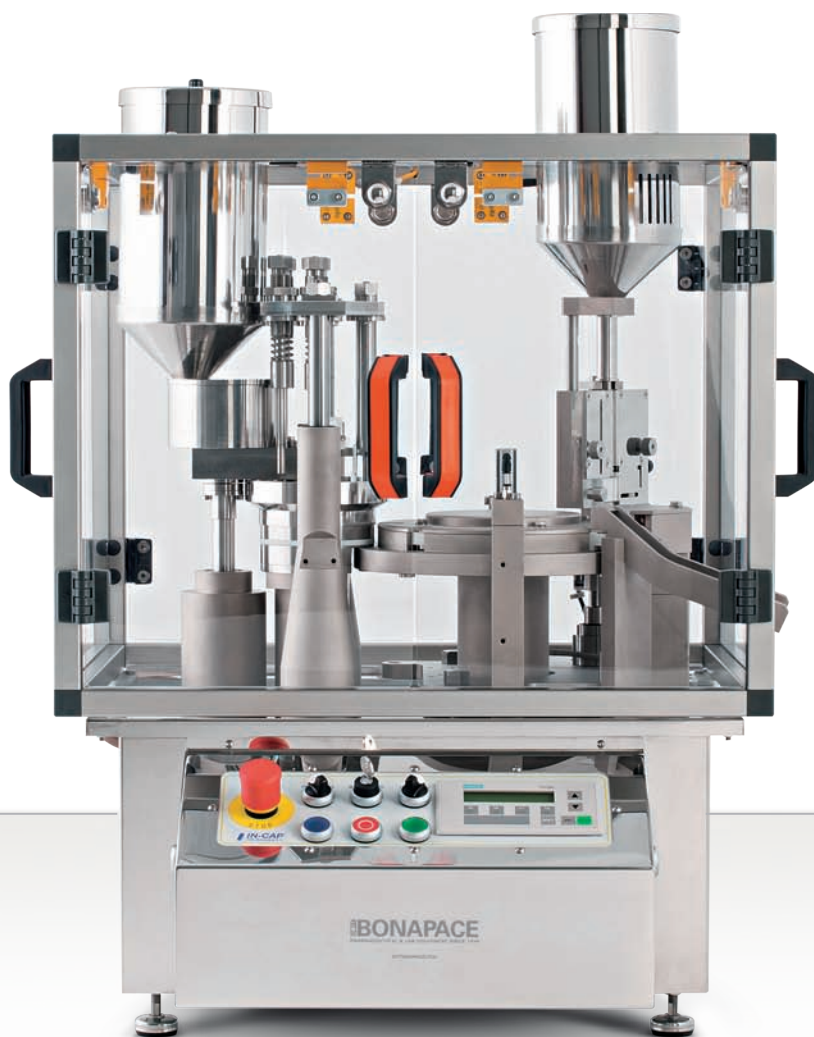

IN A FEW YEARS, THE **IN-CAP XL** HAS BECOME VERY POPULAR ALL OVER THE WORLD AMONG R&D LABORATORIES, PHARMACIES, HOSPITALS, ETC. FOR TRIALS RESEARCH, BATCH PRODUCTIONS, AND IN LABORATORIES FOR FULL PRODUCTION UTILIZATION. SUITABLE TO PROCESS POWDERS, PELLETS, LIQUIDS OR SEMI-SOLID PRODUCTS, TABLETS - MINI TABLETS AND CAPSULES (CIC). THE MACHINE CAN BE SUPPLIED EITHER WITH TAMPING OR DOSATOR POWDER SYSTEM. IT IS COMPLETELY MANUFACTURED IN ITALY ACCORDING TO CE AND GMP RULES.

OPERATIVITY:

AUTO

HOURLY OUTPUT:

**UP TO
3000
CAPSULES**

USABILITY:

**EASY
TO USE**

MODELS

IN-CAP XL

The smallest automatic capsule filler. Incredible reliability (over 20 years). **Suitable to process 3000 caps/h and over 20 filling combinations** (powders - pellets- liquids - tablets - capsule in capsule). The basic machine is supplied with the powder tamping system. Fully stainless steel version also available.

IN-CAP XL WIP

This is an IP65 version of the standard model. Completely washable. **It has been designed to process HPAPI and it is suitable to all kind of containment systems** (flexible or solid). A special IP65 utility box (positioned on the base plate) allows to connect the electronic devices. It is supplied with a remote control panel.

IN-CAP XL DP

A special version which **processes 2 different kind of powders at the same time**. It keeps the same features of a standard IN-CAP XL (3000 caps/h and over 20 filling combinations). Fully stainless steel version also available.

IN-CAP XL WIP ISOLATED

The WIP model + containment system. A complete solution to process HPAPI and flexible versions are available. Our system achieves the OEB5/OEL<1µG/M3 standard.



FILLERS



DOSATOR

An alternative to the tamping powder system. It allows processing powders unsuitable for the tamping process. This device increases the range of powders which the IN-CAP machine can process. The dosator change size kit is composed of 6 parts. Change size operation < 5min (no tools required).



PELLETS FEEDER

It has been designed to fill pellets. The machine is suitable to set 3 different pellets feeders allowing to process 3 different products at the same time. The single feeder is supplied with 3 different filling chambers (large-medium-small) to easily get the filling target required.

LIQUID FILLER

A device designed for all labs - R&D Depts - etc., which need to fill liquids into a capsule. It has a 2.3L heated hopper + an adjustable speed stirrer. The filling nozzle has been designed to fill from 0.15 mg up to 1000 mg. It is supplied with a set of different needles (large-medium-small-micro) and special lower bushings.



TABLET/ CAPSULE FILLER

A special device designed to fill tablets (mini or std) or capsules-in-capsules (CIC). It has been developed for special applications and it increases the range of possible combinations available. The size kit is composed of 5 parts, change size operation < 5 min (no tools required). The machine is suitable to set up to 3 feeders so the operator has the possibility to fill 3 different products at the same time.



+ ALL IN-CAP MODELS ARE CAPABLE TO SET THE DOSATOR, THE 3 DIFFERENT PELLETS FEEDERS, THE LIQUID FILLER AND THE TABLET/CAPSULE FILLER.

POSSIBLE FILLING COMBINATIONS (OVER 20 AND MORE)

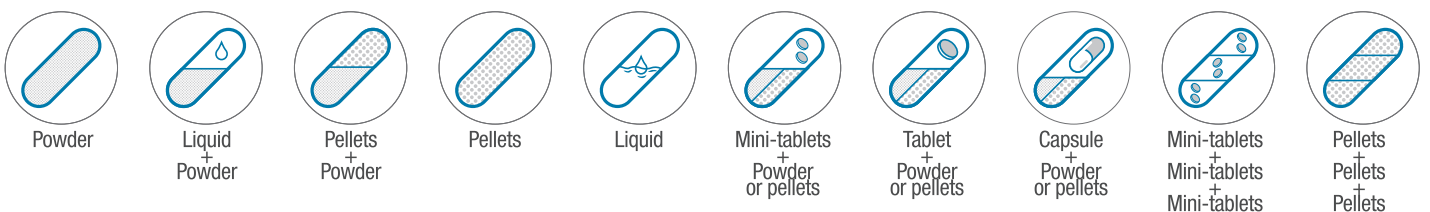

IN-CAP

TAMPING CHANGE SIZE KIT

CHANGE SIZE OPERATION TAKES LESS THAN 10 MINUTES. NO TOOL REQUIRED.

- 8 upper bushings 1
- 8 lower bushings 2
- 1 dosing disc 3
- 1 capsule orientating group 4
- 4 feeding pins 5
- 1 transfer pin 6
- 1 capsule closing pin 7
- 1 capsule closing bushing 8

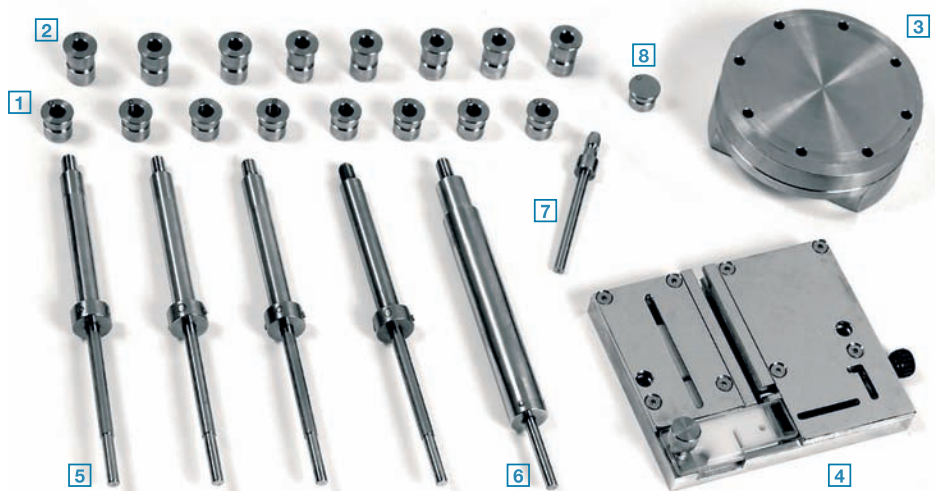

EXTRA

- + Use of DB capsules
- + Special tamping dosing discs
- + Product checking sensors
- + H16 HEPA System
- + H13 HEPA System

- + Stainless steel carriage
- + Aspirating pump
- + Noisless oil-free compressor
- + IQ/OQ validation package / Fat + Sat service

- + IN-CAP customization program
- + Tamping powder mixer
- + Powder mixer
- + Counting machine

- + Sealing/ Banding machine
- + Capsule supply
- + Checkweigher (upon request)

TECHNICAL DATA

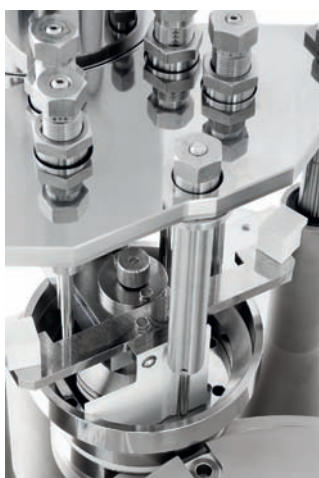

IN-CAP XL - IN-CAP XL DP IN-CAP XL WIP - IN-CAP XL WIP ISOLATED

• SIZE	70 x 70 x 95 H. cm
• NET WEIGHT (change size incl.)	130.00 Kg
• CAPSULE SIZE	000 - 00el - 00 - 0el - 0 - 1el - 1 - 2el - 2 - 3 - 4 - 5 - DB Caps
• ELECTRIC VOLTAGE	230 V – 50/60 Hz – single phase
• ELECTRIC ABSORPTION	1 KW
• DC MOTOR	160 W – 24 V
• VACUUM PUMP FOR CAPS OPENING	6m ³ /hour – Delta P. 120 mbar

KAP-100

Filling capsules has never been so easy.
1 base = filling + orienting



SEMI-AUTOMATIC

THE SMALLEST SOLUTION: TWO UNITS IN ONE. WITH ELECTRICAL PARTS IN STAINLESS BOX 100% WATER TIGHT. IDEAL FOR HOSPITALS, PHARMACIES, RESEARCH LABORATORIES AND QUALITY CONTROL DEPARTMENTS WHERE SMALL PRODUCTION BATCHES ARE REQUIRED.

HOURLY OUTPUT:

UP TO
2500
CAPSULES

• SIZE	35 x 45 x 40 H. cm
• NET WEIGHT (change size incl.)	45.00 Kg
• CAPSULE SIZE	00 - 0 - 1 - 2 - 3 - 4
• ELECTRIC VOLTAGE	230 V - 50/60 Hz - single-phase
• ELECTRIC ABSORPTION	50 W

RELATED ACCESSORIES:



KAP-300

Need a larger model? Here is the answer.
KAP-300 capsule filling unit.

THE **KAP-300** IS SUITABLE TO OPEN, FILL AND CLOSE EMPTY HARD GELATINE CAPSULES ALREADY ORIENTATED ON A 300 HOLES TRAY, AND TO ENSURE THE CORRECT AND EASY DISTRIBUTION OF THE POWDER INTO THE CAPSULES.



RELATED ACCESSORIES:



THE SECOND MACHINE OF THE "KAP" SERIES. KAP-300 INCREASES BY ABOUT 250% THE PRODUCTION CYCLE OF A KAP-100. THE STAINLESS STEEL BOX CONTAINING THE ELECTRICAL PARTS IS COMPLETE OF AN ELECTROMAGNETIC AND VIBRATING SYSTEM, IT IS FULLY DISASSEMBLABLE AND 100% AT WATER TIGHT. FOR THIS REASON, THE MACHINE CAN BE WASHED AND RINSED IN SITU BY ENSURING A GOOD CLEANING AS PER THE GMP RULES.

HOURLY OUTPUT:

UP TO
6000
CAPSULES

COMPLETE SYSTEM:

KAP
300
+
RK15

• SIZE	35 x 45 x 40 H. cm
• NET WEIGHT (change size incl.)	40.00 Kg
• CAPSULE SIZE	00 - 0 - 1 - 2 - 3 - 4
• ELECTRIC VOLTAGE	230 V - 50/60 Hz - single-phase
• ELECTRIC ABSORPTION	50 W

RK-15

Capsule orienting in just 2 operations.
Capsule orienting unit.



SEMI-AUTOMATIC

RELATED ACCESSORIES:



THE **RK-15** CAPSULE INSERTER IS AN ORIENTATOR WHICH PROCESSES 150 CAPSULES PER CYCLE; BY REPEATING THE OPERATION 300 CAPSULES CAN BE PROCESSED. IT HAS BEEN DESIGNED WITH AN ORIENTING SYSTEM COMPOSED OF SINGLE PARTS WHICH ARE DESIGNED TO AVOID THE CAPSULE LOCKING. RK-15 IS REALLY EASY TO CLEAN AND NO MAINTENANCE IS NEEDED.

• SIZE	55 x 30 x 50 H. cm
• SIZE (working position)	90 x 30 x 50 H. cm
• NET WEIGHT (change size incl.)	20.00 Kg
• CAPSULE SIZE	00 - 0 - 1 - 2 - 3 - 4

HOURLY OUTPUT:

UP TO
6000
CAPSULES

COMPLETE SYSTEM:

KAP
300
+
RK15

DOTT **BONAPACE**
PHARMACEUTICAL & LAB EQUIPMENT SINCE 1946

DOTT. BONAPACE & C. srl
Via Isonzo, 12
20812 Limbiate - MB - ITALY
www.dottbonapace.com

Phone +39 02 331221
Fax +39 02 3490005 / +39 02 3312222
P.IVA VAT N° IT 00720310150
dottbonapace@dottbonapace.com

DOTTBONAPACE.COM