

FORZA DI CHIUSURA MOULD CLAMPING FORCE FUERZA DE CIERRE FORCE DE FERMETURE	<b>kN</b>	<b>20</b>
---	-----------	-----------

Carro singolo / Single station /  
Estación simple / Chariot simple

Carro doppio / Double station /  
Estación doble / Chariot double

		PB2ES-200	PB2ES-230	PB2ES-260	PB2ED-200	PB2ED-230	PB2ED-260
<b>DATI GENERALI / GENERAL DATA / DATOS GENERALES / DONNÉES GÉNÉRALES</b>							
Stampi / Moulds / Moldes / Moules	n°	1	1	1	2	2	2
Corsa / Stroke / Carrera / Course	mm	200	230	260	200	230	260
Ciclo a vuoto / Dry cycle time / Ciclo en vacío / Cadence à vide	s	1,1	1,2	1,3	1,1	1,2	1,3
Potenza motore chiusura / Motor clamping power / Potencia motor de cierre / Puissance moteur de fermeture	kW	1,4			1,4		

<b>CONSUMI / CONSUMPTIONS / CONSUMOS / CONSOMMATIONS</b>							
Pressione aria / Air pressure / Presión aire / Pression air	bar	6 ÷ 8			6 ÷ 8		
Consumo aria / Air consumption / Consumo aire / Consommation air	Nl/min	500			1000		
Pressione acqua / Cooling water pressure / Presión agua / Pression eau	bar	3 ÷ 5			3 ÷ 5		
Raffreddamento stampi HDPE / Mould cooling HDPE / Enfriamiento moldes HDPE / Refroidissement moules HDPE	KJ/Kg	650			650		

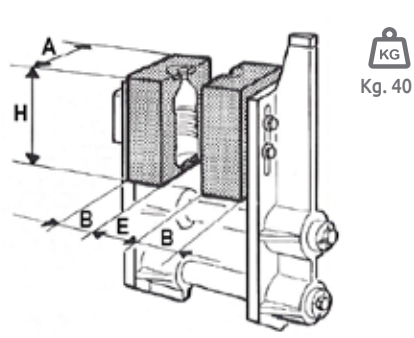
<b>STAMPO / MOULD / MOLDE / MOULE</b>		PB2ES-200	PB2ES-230	PB2ES-260	PB2ED-200	PB2ED-230	PB2ED-260
	A mm	220	240	280	190	220	250
	H mm	210			210		
	B mm	55 ÷ 65			50 ÷ 60		
	E mm	110			110		

CD	<b>INTERASSE USCITE / CENTER DISTANCE / DISTANCIA ENTRE CENTROS / ENTRAXE FILIÈRES</b>			
N. Cav	2	3	4	5
C = 200	65	40	-	-
C = 230	80	50	40	-
C = 260	95	60	45	35

C = Corsa / Stroke / Carrera / Course

<b>ESTRUSORE / EXTRUDER / EXTRUSORA / EXTRUDEUSE</b>		E42/24	E50/25
Diametro vite / Screw diameter / Diámetro husillo / Diamètre vis	mm	42	50
Lunghezza vite / Screw length / Largo husillo / Longueur vis	L/D	24	25
Potenza motore / Motor power / Potencia motor / Puissance moteur	kW	9	18
Plastificazione HDPE / HDPE plasticizing / Plastificación HDPE / Plastification HDPE	kg/h	26	56

**DIMENSIONI E PESO / DIMENSIONS AND WEIGHT / DIMENSIONES Y PESO / DIMENSIONS ET POIDS**

Carro doppio / Double station / Estación doble / Chariot double	
	A x B x H
C = 200	2540 x 2300 x 3700 4000 kg
C = 230	2540 x 2300 x 3700 4000 kg
C = 260	2540 x 2300 x 3700 4000 kg

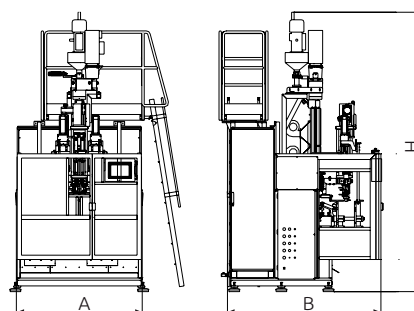

Carro doppio / Double station / Estación doble / Chariot double