

EARTHSTONE OVENS

WOOD, GAS & COAL FIRE OVENS

PRE-ASSEMBLED INSTALLATION INSTRUCTIONS FOR DUE' OVEN SERIES



**A MAJOR CAUSE OF OVEN RELATED FIRES IS FAILURE TO MAINTAIN
REQUIRED CLEARANCES (AIR SPACES) TO COMBUSTIBLE MATERIALS. IT IS
OF UTMOST IMPORTANCE THAT THIS OVEN BE INSTALLED ONLY IN
ACCORDANCE WITH THESE INSTRUCTIONS**

12/4/2013

EARTHSTONE WOOD FIRE OVENS 6717 SAN FERNANDO RD, GLENDALE CA 91201

Pre-Assembled installation instructions.

<u>Table of contents</u>	Page
<u>Instructions for moving and lifting oven</u>	
Parts list	1
Installation procedures written portion	2-5
Required clearances and air gaps	6,14
Exhausting	4-9,13-14
Operating instructions	10-12
Maintenance instructions	11-12
Type I Exhaust Hood Diagram	13
Clearance Information	14
Combustion air intake installation	15-16
Firing Instructions	18-19

INSTRUCTIONS FOR LIFTING AND MOVING OVEN

ATTENTION: Only proper heavy lifting machinery and handling equipment should be used for unloading, moving and installing the oven. This duty should be performed by professionals trained in this kind of work. Improper handling of the equipment could result in damaging the oven or personal injury.

1- USING A FORKLIFT

Determine if forklift capacity is sufficient to lift oven. (7,000 lb for 90-Due, 10,000 lb for model 110-Due', and 12,000 lb for models 130-Due')

Prior to lifting, make sure forks are long enough to reach both horizontal steel tubes on underside of oven (Without touching oven shell). Approach oven from front entrance side or rear side. Keep forklift straight. Carefully place forks through inside of tube steel supports legs and position under horizontal tube steel members. Slowly lift and move oven as needed. (See dia. A)

2- USING A PALLET JACK

Determine if pallet jack capacity is sufficient to lift oven. (6000 lb for 110-Due' and 130-Due')

Prior to lifting, make sure pallet jack is long enough to reach both horizontal angles at lower end of steel tube support legs. Place pallet jack between tube steel support legs under horizontal angles. (See dia. B) Carefully lift oven and move slowly.

CAUTION: OVEN IS TOP HEAVY
MOVE WITH CARE.

3- INSTALLING OVEN

Slowly lower oven into proper location. Oven should be set on a level floor. Shim as necessary to assure that oven is level. Remove horizontal front angle when oven is in place. Insert ramset red heads, min. of 3 inches in length, through base plates. (See fig 17-A pg. 7 in installation instructions)

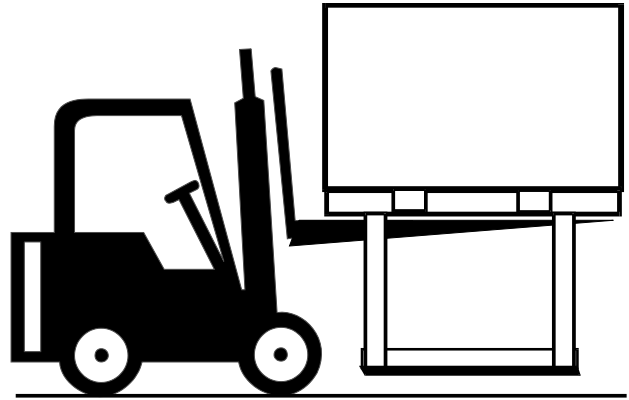

DIA. A

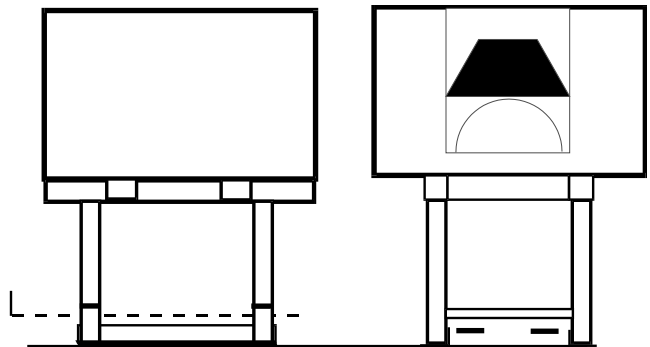

DIA. B

LIST OF SUPPLIED ITEMS

- ALUMINUM DOOR (Two doors with double opening option)
- DIAL TEMPERATURE GAUGE FOR WOOD FIRE OVENS
- DIGITAL THERMOMETER DISPLAY FOR GAS AND GAS/WOOD OVENS (REQUIRES 120V-3 AMP per display)
- TRAINING VIDEO

PRE-ASSEMBLED INSTALLATION INSTRUCTION GUIDE

READ ALL INSTRUCTIONS CAREFULLY BEFORE INSTALLING AND USING THE APPLIANCE.

If this oven is not properly installed, a fire may result. To reduce the risk of fire, follow the installation instructions. Please read this entire manual before you install the oven. Failure to follow instructions may result in property damage, bodily injury, or even death.

The installer should contact the local building or fire officials concerning any installation restrictions and the need for inspection(s) of the oven and venting applications before beginning installation.

Obtain the necessary permit to construct. In most areas this will include a permit to construct the oven and a permit for the exhaust system. Sometimes an electrical permit is also necessary for connecting the exhaust fan. All construction must comply with local building codes. There are some portions of these instructions which are more restrictive than the building codes. Whichever is most restrictive must be followed.

The diagram below indicates the minimum floor space required.
(ALL DIMENSIONS ARE TO OUTSIDE FACE OF STEEL ENCLOSURE)

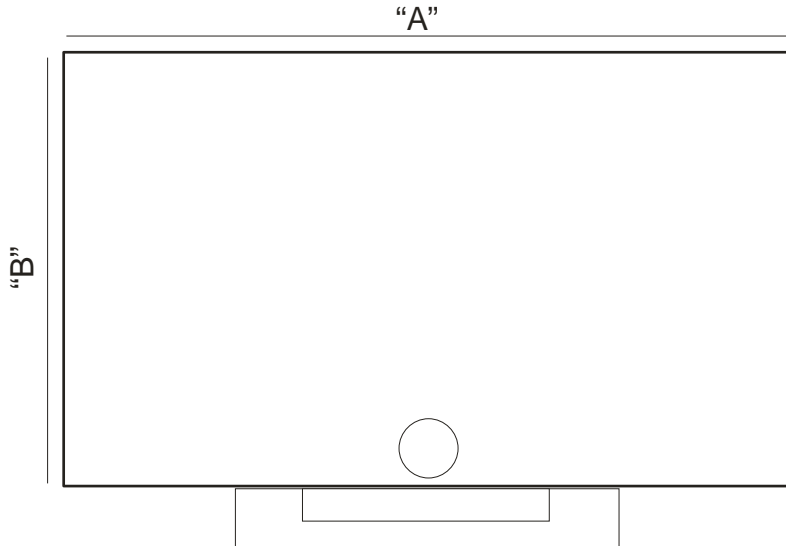

OUTSIDE DIMENSIONS

Model 90-Due 60" (A) x 44" (B) 4,000 lbs 110-Due' 96.25" (A) x 54.25" (B) 5,000 lbs

Model 130-Due' 116.25" (A) x 66.25" (B) 8,000 lbs.

IMPORTANT REMINDER

After reading this installation guide it is important to determine which venting application method will be used.

Most cities accept the U.L. listed chimney installation (direct venting) however a few cities will require the use of a Type I grease hood over the oven opening. Check with your local building department to determine which is acceptable.

To maintain the listing of the oven the venting application needs to be installed in accordance with the guidelines specified in this installation instruction guide.

SAVE THESE INSTRUCTIONS

INSTALLATION. OPERATING AND MAINTENANCE PREFACE

Refer to pages 9, 10 and 11 for complete instructions.

- 1) On daily basis and after the oven temperature is at least 500 at F: (a) Ashes are to be removed by a metal ash scoop/shovel or by a suitable fire-safe vacuum cleaner with long metal wand extensions provided by the user; (b) the oven interior is then to be mopped down with a clean, damp cloth.
- 2) Direct food contact with hearth is restricted to pizzas and bread products only. Refer to manufacture for other foods.
- 3) The manual recommends the use of untreated wood only, no more than four pieces at a time.
- 4) "Burn-in" conditioning instructions are provided on page 30 and are to be followed prior to initial use unless "burn-in" is conducted by the manufacturer.
- 5) Field applied enclosures, paint, brickwork, panels, or other construction necessary to "finish off" the oven must be in accordance with local public health requirements.
- 6) Cooking shall only take place when the oven hearth is at least at 500°F.
- 7) The mantle shelf joint shall be sealed with an NSF Listed sealant after final installation.

A. INSTALLATION PROCEDURES

1. Mark an outline on the floor of the location desired. This is to assure that you have adequate space. Refer to Fig. 1, pg. 6.
2. Check that there is adequate clearance at the ceiling for the hood. There must be a minimum of 3 inches of clearance between the top of the hood and/or oven and the surface of the drywall above. A height of 105 inches is needed for a basic installation (Including hood – 22” height). If direct venting is used then 83 inches will be sufficient. (Refer to Fig. 2 & 3 pg. 6)
3. Check that there is a minimum clearance of 1 inch to any adjacent sidewall construction containing combustibles. Any adjacent combustible sidewalls which projects beyond the front of the oven opening must be a minimum of 48 inches, measured from the side of the oven opening closest to the wall to the surface of the wall. (Refer to Fig. 4, pg. 6). If the distance is less than 48 inches a wall shield must be mounted on the wall. Refer to the U.L. listed wall shield installation instructions for the allowable clearance reduction.

Any adjacent combustible floor which projects in front of the oven opening must be a minimum of 30 inches away from each side of the door opening and 36 inch from the front of the door opening.

WARNING: DO NOT PACK REQUIRED AIR SPACES WITH INSULATION OR OTHER MATERIALS

A minimum of 3 inches must be maintained between any combustibles and the top of the metal covering over the oven enclosure. Refer to Fig 2 & 3 pg. 6.

4. Once the oven is in the desired position, drill holes for the anchor bolts (Min 4 inches deep) using the base plates as a guide. Insert anchors to fasten oven base plates to concrete floor. (Fig 17-A pg. 8) Use ½” Dia. Anchors, 3 anchors each side. (Coat with Simpson's Epoxy)
5. The outside surface of the oven enclosure may be faced with non-combustible facing material if desired. This might include but not limited to: Brick, Ceramic tiles, Stainless steel, Marble or any other decorative metals. **DO NOT FACE WITH COMBUSTIBLE MATERIALS OR USE COMBUSTIBLE ADHESIVES. Allow for access to top of the oven for servicing.**

NOTE: FOR HEALTH DEPARTMENT REQUIREMENTS ANY 1-INCH AIR GAP ADJACENT TO A COMBUSTIBLE WALL MUST BE SEALED WITH A NON COMBUSTIBLE STRIP. i.e. ALUMINUM, STAINLESS STEEL OF TILE.

B. VENTING APPLICATIONS

THERE ARE TWO METHODS OF VENTING THAT ARE ACCEPTABLE TO USE WITH THE OVEN. THE METHODS ARE A U.L. LISTED GREASE DUCT/BUILDING HEATING APPLIANCE CHIMNEY INSTALLATION (DIRECT VENTING) AND TYPE-I EXHAUST HOOD INSTALLED PER NFPA 96 AND THE UMC. DETERMINE WHICH METHOD OF VENTING IS ACCEPTED BY THE LOCAL BUILDING DEPT. BEFORE BEGINNING INSTALLATION OF THE OVEN. RESIDENTIAL APPLICATIONS WILL USE THE DIRECT VENTING METHOD. **IT IS NEVER APPROPRIATE TO USE “CLASS A” OR “B VENT” IN ANY PART OF THE EXHAUST SYSTEM. EXHAUST SYSTEMS SERVING SOLID-FUEL EQUIPMENT MAY NOT BE COMBINED WITH EXHAUST SYSTEMS SERVING OTHER (NON-SOLID FUEL) COOKING EQUIPMENT**

Important: Chases should be made of non-combustable materials.

I TYPE-I EXHAUST HOOD-Installed per NFPA 96, standard for ventilation control and fire protection of commercial cooking operations. (For commercial applications only)

1. If required, a Type 1 hood must be placed above the cooking opening and set on the top of the oven. The minimum exhaust hood dimensions are 40 in. long for 90-Due, 52" long for 110-Due, and 60". long for 130-Due. 72" long for 110-Due double entrance and 90 in. long for 130-Due with double entrance. Min depth is 37" and min height is 22" for all hoods. Refer to pages 7 & 8. **Duct Velocity 1500-2500 FPM - Volume: 40" hood 1050 CFM , 90" hood - 2250 CFM**
2. The grease filters must be positioned at the rear of the exhaust hood and must be of the steel baffle type (Mesh type grease filters must not be used).
3. The front of the exhaust hood is to set forward 10 inches from the front of the oven face. The face of the filter must be a minimum of 42 inches from the oven heath per the Uniform Mechanical Codes. (UMC) or 48 inches per NFPA 96. When the exhaust hood is fabricated, it is recommended that the bottom portion which is set on the oven(sheet metal lid) be closed for ease of cleaning. Refer to pages 7 & 8.
4. The sides of the exhaust hood must extend a minimum of 6 inches to either side of the oven door opening.
5. There must be a minimum of 3 inches of clearance between the hood and any combustible surface.
6. The exhaust duct is to be constructed as vertical as possible, free of offsets and horizontal runs. If a horizontal run is needed then refer to the Grease Duct/Building Heating Appliance installation section.

II. U.L. LISTED GREASE DUCT/BUILDING HEATING APPLIANCE CHIMNEY INSTALLATION (DIRECT VENTING)

1. **A U.L. listed Grease Duct/Building Heating Appliance Chimney may be connected to the flue collar above the primary hood of the oven. Refer to Fig. 18, pg. 9. For specific installation requirements refer to Selkirk Metalbestos Model PS and IPS Grease Duct Installation Instructions or Metal-Fab IPIC Installation Instructions.**

A field-built duct, constructed and installed to the specifications of a grease duct, as detailed in NFPA 96 or the International Mechanical Code, may also be used.

Volume: 150-200 CFM at oven flue collar

**Models: Metal-Fab IPIC or Value G (metal-fabcommercial.com)
or Selkirk Metalbestos Model IPS (selkirkcorp.com)**

WOOD STORAGE

Wood storage shall not exceed a one-day supply where stored in the same room as the oven. Refer to NFPA 96 for wood storage requirements.

OVEN CURING

Oven is pre-cured; however the first two fires should be small in order to properly cure the masonry in the unit. One fire each day for one hour, for a total of two days.

ALL CLEARANCES SPECIFIED ARE THE MINIMUM REQUIRED AIR SPACES

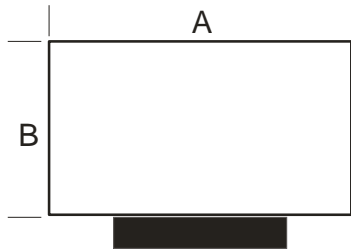

Outside Dimension

MODEL 90-Due' - (A) 60" x (B) 44"

MODEL 110-Due' - (A) 92.25" X (B) 54.25"

MODEL 130-Due' - (A) 116.25 X (B) 66.25"

Figure 1

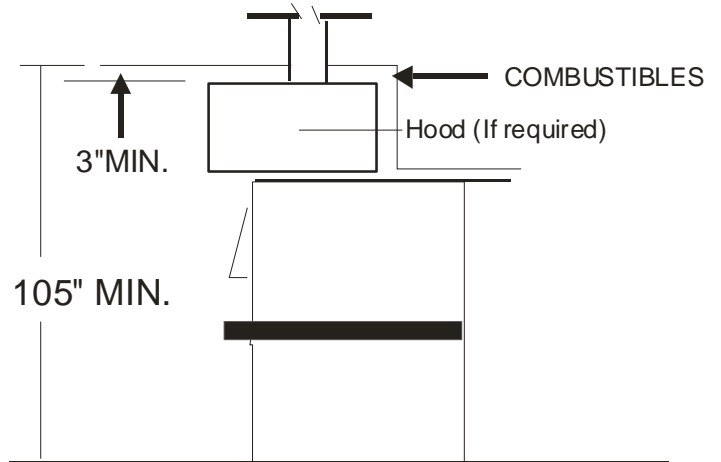

FOR COMMERCIAL USE ONLY

Figure 2

U.M.C. & N.F.P.A.

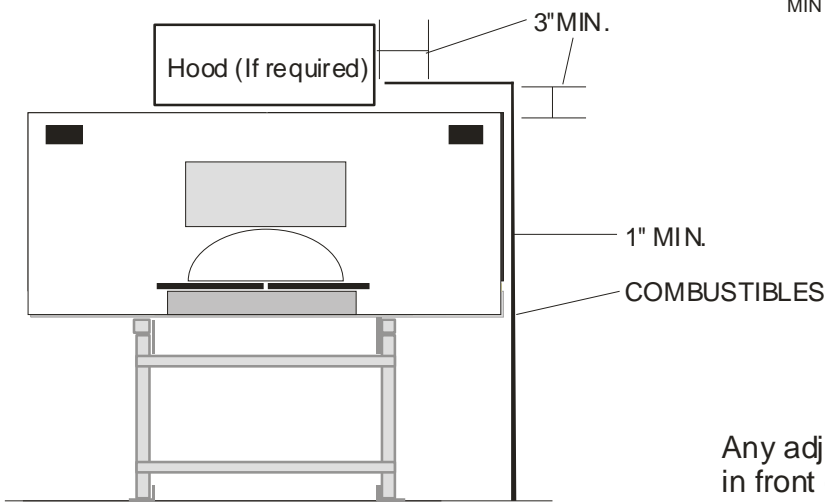

FOR COMMERCIAL USE ONLY

Figure 3

U.M.C. & N.F.P.A.

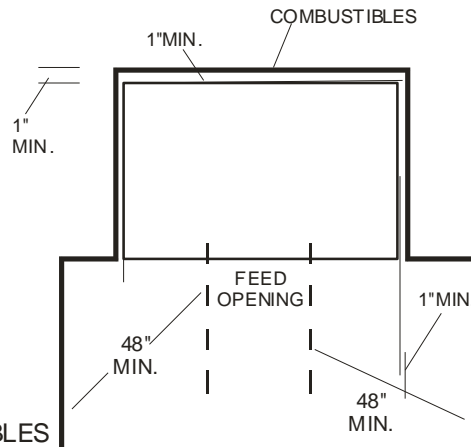

Any adjacent combustible floor which projects in front of the oven opening must be a minimum of 30 inches away from each side of the door opening and 36 inches from the front of the door opening. See Page 14 for more information

Figure 4

WARNING: DO NOT PACK REQUIRED AIR SPACES WITH INSULATION OR OTHER MATERIALS.

Exhaust Hood Diagrams

Height for all hoods – 22" min.

Single Opening Models 90-Due' 110-Due' and 130-Due' (Dimensions are minimums)

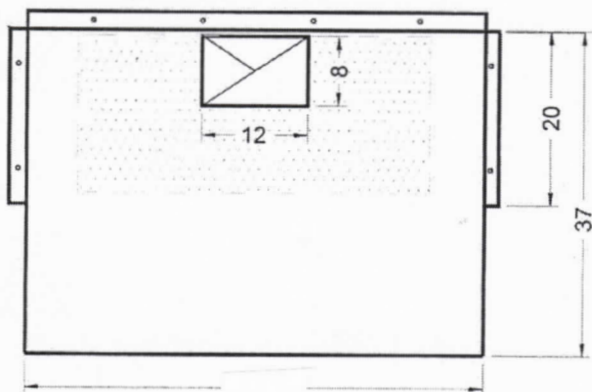

40" min for 90-Due
 52" min for 110-Due
 60" min for 130-Due

Double Opening Models 110-Due' and 130-Due' (Dimensions are minimums)

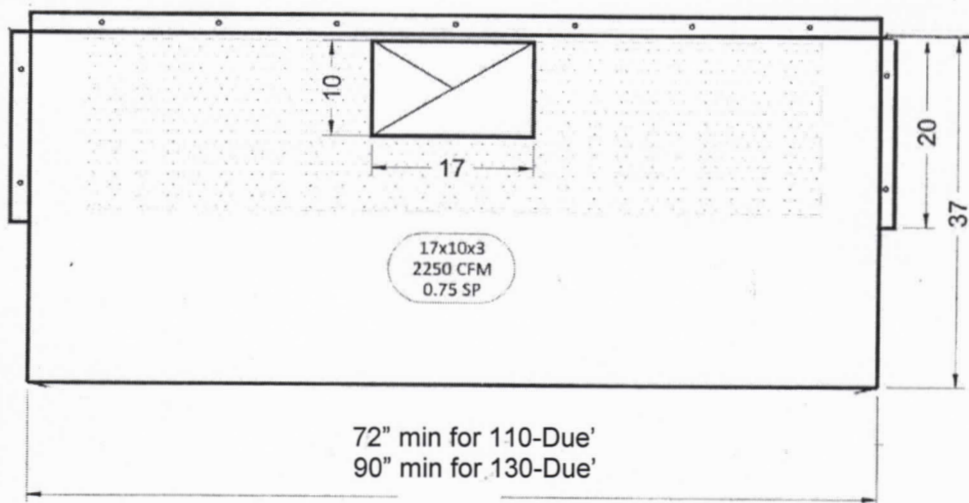

72" min for 110-Due'
 90" min for 130-Due'

FIGURE 16

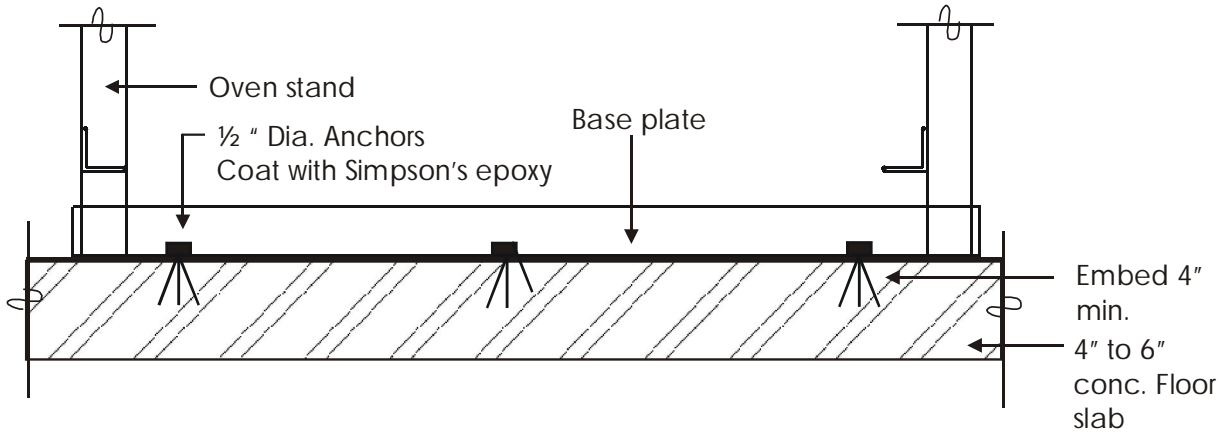

FIGURE 17-A

COMMERCIAL DIRECT VENTING

6 INCH DIAMETER GREASE DUCT - Models - 90, Café, 110, 110-Due (Dual opening)

8 INCH DIAMETER GREASE DUCT - Models 90-Due, 120, 130, 160, 110-Due (Single opening), 130-Due (Dual opening)

10 INCH DIAMETER GREASE DUCT - Model 130-Due (Single opening)

EXHAUST FAN AND CURB POWER VENTILATOR FOR RESTAURANT EXHAUST APPLIANCES. RATED FOR 500F DEG MODELS: ENERVEX GSV SERIES. CALL EARTHSTONE FOR DETAILS 800-840-4915 - 818-553-1134

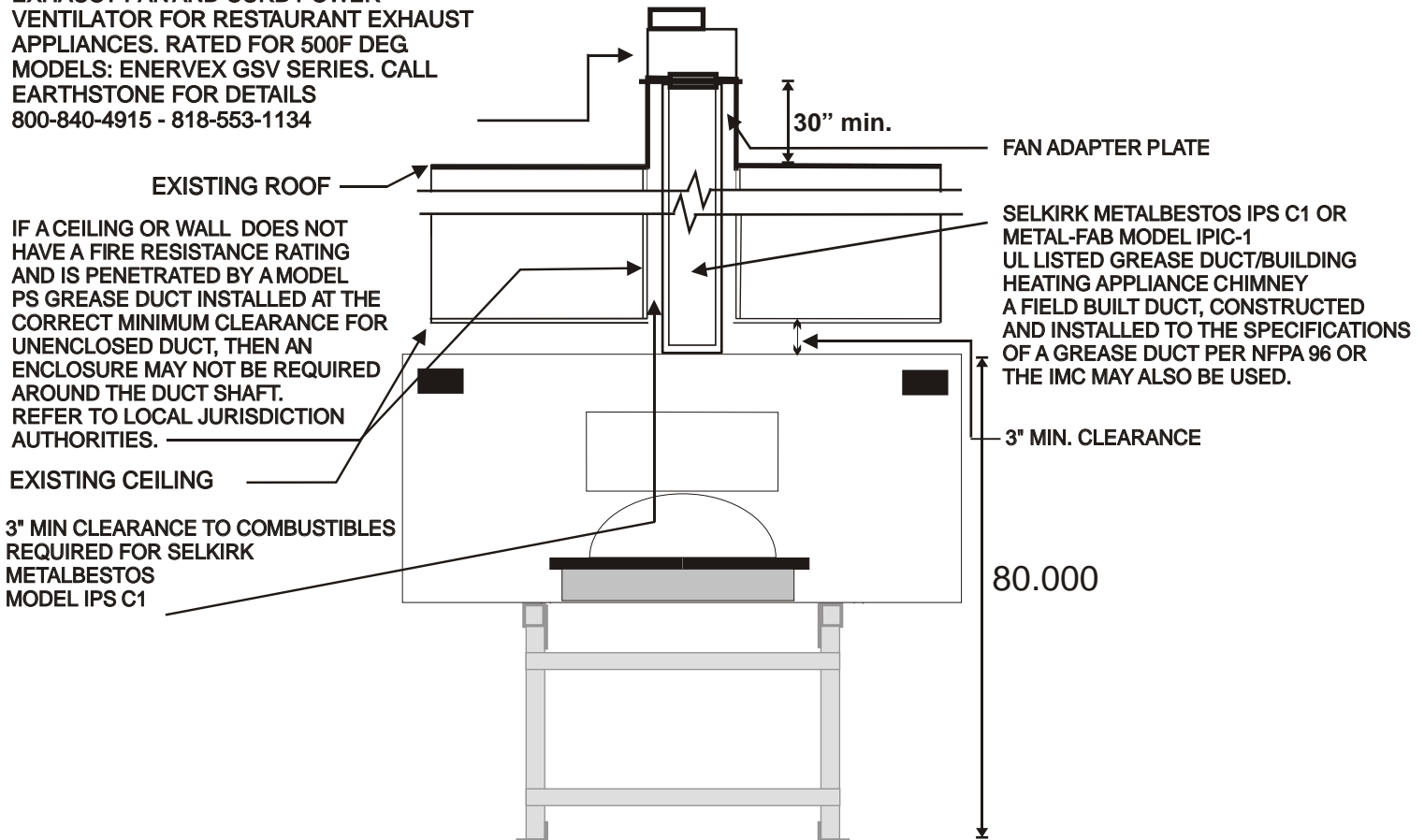

FIGURE 18

GREASE DUCT HEATING APPLIANCE CHIMNEY ATTACHED TO PRIMARY HOOD

THIS DIAGRAM GENERALLY DEPICTS THE INSTALLATION REQUIRED TO MAINTAIN THE U.L. LISTING OF THE OVEN FOR THIS TYPE OF VENTING APPLICATION.

FOR SPECIFIC INSTALLATION REQUIREMENTS REFER TO SELKIRK METALBESTOS MODEL IPS GREASE DUCT INSTALLATION 8. MODEL PS AND IPS GREASE DUCT COMPLIES WITH NFPA, SBCCI, ICBO AND BOCA WHEN PROPERLY INSTALLED PER ITS INSTALLATION INSTRUCTIONS.

CONTACT LOCAL AUTHORITY HAVING JURISDICTION REGARDING FIRE RATED DUCT SHAFT.

NOTE: OTHER U.L. LISTED SYSTEMS MAY BE SUBSTITUTED FOR THE METALBESTOS SYSTEM DEPICTED IN THIS DIAGRAM. TO MAINTAIN THE U.L. LISTING OF THE OVEN THE SYSTEM MUST BE A U.L. LISTED GREASE DUCT WHICH IS ALSO A U.L. LISTED BUILDING HEATING APPLIANCE CHIMNEY INSTALLED IN ACCORDANCE WITH THE MANUFACTURER'S GREASE DUCT INSTALLATION INSTRUCTIONS.

WOOD-FIRED PIZZA OVEN OPERATING INSTRUCTIONS

WARNING:

READ ALL INSTRUCTIONS CAREFULLY. IMPROPER USE OF THIS APPLIANCE MAY RESULT IN A BUILDING FIRE OR PERSONAL INJURY. INSTRUCTIONS MUST BE READ AND THOROUGHLY UNDERSTOOD BY ALL OPERATING AND SUPERVISING PERSONNEL. WATCH TRAINING VIDEO FOR VISUAL OPERATION INSTRUCTIONS.

THIS OVEN IS INTENDED FOR ATTENDED OPERATION BY TRAINED AND QUALIFIED PERSONNEL ONLY.

THIS OVEN IS A HEAT PRODUCING APPLIANCE AND MAY CAUSE SEVERE BURNS IF TOUCHED.

DO NOT OVERFIRE. IF FLAME SPILLS FROM THE DOOR OPENING OR OVEN TEMPERATURE EXCEEDS 1000 DEGREES FAHRENHEIT, YOU ARE OVERFIRING.

THIS UNIT IS DESIGNED AS A WOOD-FIRED OVEN. DIRECT FOOD CONTACT WITH HEARTH IS RESTRICTED TO PIZZA AND BREAD PRODUCTS ONLY. FOR OTHER FOODS REFER TO MANUFACTURE.

KEEP A PROPER FIRE EXTINGUISHER CLOSE TO THE OVEN AT ALL TIMES. EXTINGUISHER MUST BE RATED FOR USE ON WOOD FIRES. INSTRUCT ALL PERSONNEL ABOUT LOCATION AND USE OF THE FIRE EXTINGUISHER AND PROPER FIRE EMERGENCY PROCEDURES.

1. The first six fires should be small in order to properly cure the masonry in the unit. One fire each day for one hour, for a total of two days (see gas fire instructions for curing gas models). DO NOT USE PRODUCTS NOT SPECIFIED FOR USE WITH THIS OVEN. Maintain a minimum clearance of 36 inches in front of oven to combustible materials.
2. In case of out of control fire close door tightly.

CAUTION--AVOID POSSIBLE HAZARDOUS FLARE-UPS AND SMOKE SPILLAGE. WHEN REMOVING DOOR FROM IN FRONT OF DOOR OPENING, SLIDE DOOR OUT 2-3 INCHES FROM OPENING AND THEN WAIT 15 SECONDS BEFORE REMOVING DOOR COMPLETELY. FLARE-UPS CAN OCCUR WHEN DOOR IS OPENED SUDDENLY. KEEP FACE AND HANDS AWAY FROM DOOR OPENING.

3. Burn only seasoned or dried untreated solid wood fuel in the oven. **DO NOT BURN OTHER FUELS IN THE OVEN. DO NOT BURN CHARCOALS, COALS, TRASH/GARBAGE OR MANUFACTURED LOGS (PROCESSED SOLID FUEL).**
4. Firewood stored in the vicinity of the oven must be kept in a tightly-closed metal container; see maintenance Instructions and NFPA 96. Keep firewood container closed at all times when not adding or removing firewood. Keep container a considerable distance from the oven and far away from sources of heat or ignition. DO NOT store matches, paper or other easily ignited items with firewood.
5. Provisions must be made to supply sufficient combustion air into the structure when using this appliance. Combustion air must be supplied in accordance with local codes and the Uniform Mechanical Code and NFPA 96.. Exhaust hood and make-up air blowers must be "ON" at all times during firing of the oven. If the exhaust hood power ventilator fails, close oven door to extinguish the fire and prevent temperature buildup in the hood duct which can activate the emergency fire suppression system.
6. Use only non-combustible hearth tools and cooking implements inside the oven. Store implements well away from all combustible materials in a proper fixture which will capture any ashes or hot coals which may be carried out of the oven on the implements.

7. The fire should be built directly on the hearth; DO NOT elevate fire.
FIRING OVEN- NOTE: OVEN DOOR SHOULD BE REMOVED WHEN FIRING THE OVEN.
8.
 - a- Before starting, turn "ON" exhaust fan and make-up air blowers.
 - b- Place a small amount of wood and kindling on the hearth over a fire-starter block. Light fire-starter. At any time do not use more than four pieces of wood,
 - c- CAUTION: NEVER USE GASOLINE TYPE LANTERN FUEL, KEROSENE, CHARCOAL LIGHTER FLUID OR SIMILAR PRODUCTS TO START OR "FRESHEN UP" A FIRE IN THIS OVEN. KEEP ALL SUCH LIQUIDS WELL AWAY FROM THE OVEN WHEN IN USE.
 - d. When the kindling is burning well, add larger pieces of firewood. USE WELL-SEASONED OR DRIEDWOOD ONLY. (Oak, Almond, Walnut, Cherry, Apple and other fruit woods are good)
 - e- Continue to add fuel as needed to maintain the desired heated rate, being careful to never overfire the unit.
 - f- Whenever fuel is added, the fire may be poked and stirred with a wood handling tool. This will allow air to move through the fuel bed for proper combustion.
 - g- When oven is heated to cooking temperature, move wood and ash to the rear and sides of the oven to clear the hearth for cooking product. Insert ash barrier in front of burning wood. This is to separate the cooking area from the ash and wood. Clean cooking area as described in the DISPOSAL OF ASHES section before commencing cooking procedures. Food must be placed on an appropriate cooking pan before being set into the oven.
 - h- When finished cooking, spread remaining embers on the floor of the oven hearth. Close door against door opening. This will clean the oven floor.
9. **CAUTION:** Many structure fires have resulted when a fire has been left unattended for an extended period of time such as when "Banking" a fire for a long overnight burn. This oven is intended for attended operation only. Trained personnel must attend and closely supervise the oven at all times during firing.

DO NOT LEAVE AN UNATTENDED FIRE IN THE OVEN. CLOSE DOOR TIGHTLY AND WAIT UNTIL FIRE IS EXTINGUISHED BEFORE LEAVING UNIT UNATTENDED.
10. Always keep the area around the unit clear of combustible objects.
11. Read Maintenance Instructions.
12. File these instructions for future reference.

MAINTENANCE INSTRUCTIONS

WARNING:

READ ALL INSTRUCTIONS CAREFULLY. IMPROPER USE OR MAINTENANCE OF THIS APPLIANCE MAY RESULT IN A BUILDING FIRE OR PERSONAL INJURY.

1. Always keep area around the unit clean and clear of all combustible materials. Keep all furnishings, fuel and other combustible objects a considerable distance away from the oven hearth.
2. **DISPOSAL OF ASHES**—Ashes from Ash Pan should be placed in a metal container with a tight-fitting lid. The closed container should be placed on a non-combustible floor or on the ground, well away from all combustible materials, pending final disposal. If the ashes are disposed by the burial in soil or

otherwise locally dispersed, they should be retained in the closed container until all cinders have thoroughly cooled. After ashes have been removed mop down hearth with clean damp cloths.

3. Store wood in a cool, dry place well away from any source of flame or heat. If stored outside, keep the fuel covered to protect from rain or snow. If stored inside, fuel should be kept in a covered metal container at least 6 inches above the floor. Keep paper, rags and other easily ignited materials away from wood fuel. Refer to NFPA 96 for wood storage procedures.
4. At least at the end of each shift the area around the unit must be thoroughly cleaned of all wood, wood shavings, embers, ashes and other refuse. All mats (if present, mats must be non-combustible) must be picked up and carefully swept along with the floor during this clean up. After clean up around the unit, brooms should be thoroughly wet down to extinguish hot coals, then stored well away from combustible materials.
5. **Creosote - Formation and need for removal**

When wood is burned slowly, it produces tar and other organic vapors, which combine with expelled moisture to form creosote. The creosote vapors condense in the relatively cool oven flue and exhaust hood of duct, particularly a slow burning fire. As a result, creosote residue accumulates on the flue lining and exhaust hood. When ignited, this creosote makes an extremely hot fire.

The oven flue, exhaust duct and power ventilator should be inspected at least twice monthly during normal use to determine if creosote buildup has occurred. If creosote and/or grease has accumulated, it should be removed to reduce the risk of fire. Experienced chimney and duct servicing personnel who are qualified in the removal of both creosote and grease from flues and ducts should be contracted to do the inspection and cleaning. The inspection and cleaning schedule must be adjusted as needed to prevent the buildup of creosote and/or grease. More frequent inspections and cleanings are indicated when excessive buildup occurs between regular inspections. The rate of accumulation can increase whenever 1) there is a change in the use of the oven 2) when the type or moisture content of the firewood changes 3) when other variables change.

The oven, exhaust hood and grease filters should be cleaned on a daily basis. The Grease filters can be removed and cleaned in a dishwasher or sink. Refer to the NFPA 96 requirements and the Exhaust Hood or Grease Duct manufacturer's instructions for inspection, maintenance and cleaning of the venting system.

DO NOT CLEAN UNIT, HOOD OR VENT WHILE HOT OR WHILE OVEN IS BEING FIRED.

6. The entire unit and vent system should be inspected frequently for proper fit, operation and soundness of parts. If any malfunctioning parts, leakage, deterioration, or other problems are noted, contact your dealer to inspect and repair the unit, or qualified ventilation repair service to inspect and repair the vent system. DO NOT OPERATE THE UNIT IF INSTALLED OR FUNCTIONING IMPROPERLY.
7. All maintenance must be performed by qualified personnel.
8. Refer to NFPA 96 for procedures for inspection, cleaning and maintenance for solid fuel cooking.
9. **SERVICE OF OVEN TEMP. MONITORING EQUIPMENT**
 - A) Replace with Temp. Gauge rated 6-14 VDC, Temp. Range -58⁰F to 932⁰F. (Earthstone Ovens Model ESO-TTC)
 - B) Replace AC adapter with U.L. listed plug-in class 2 transformer rated input 120 VAC, 60 HZ, 9 Watts, output 9 VDC, 200 Ma.
 - C) Replace Thermocouple with a metal sheathed Type-"K" thermocouple, Min. 6 ft.
10. Save these instructions for future reference.

Type-I Exhaust Hood Installed per NFPA 96

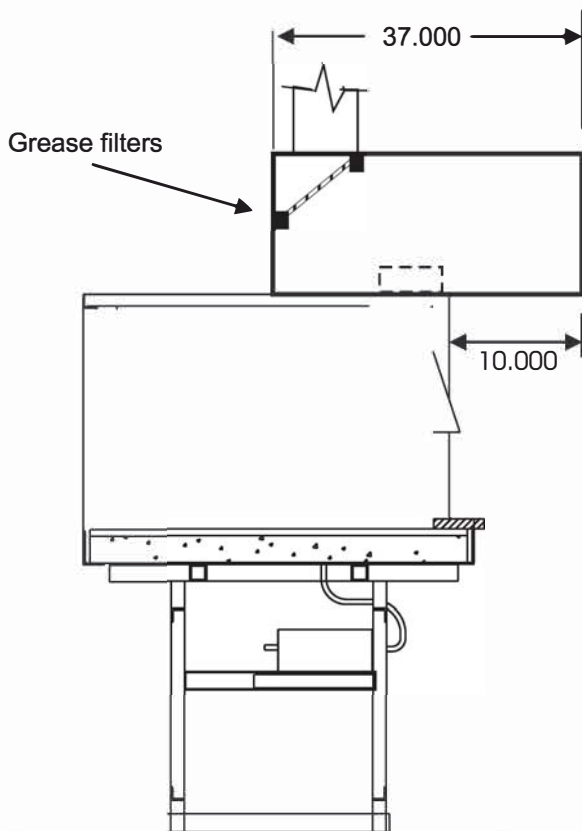
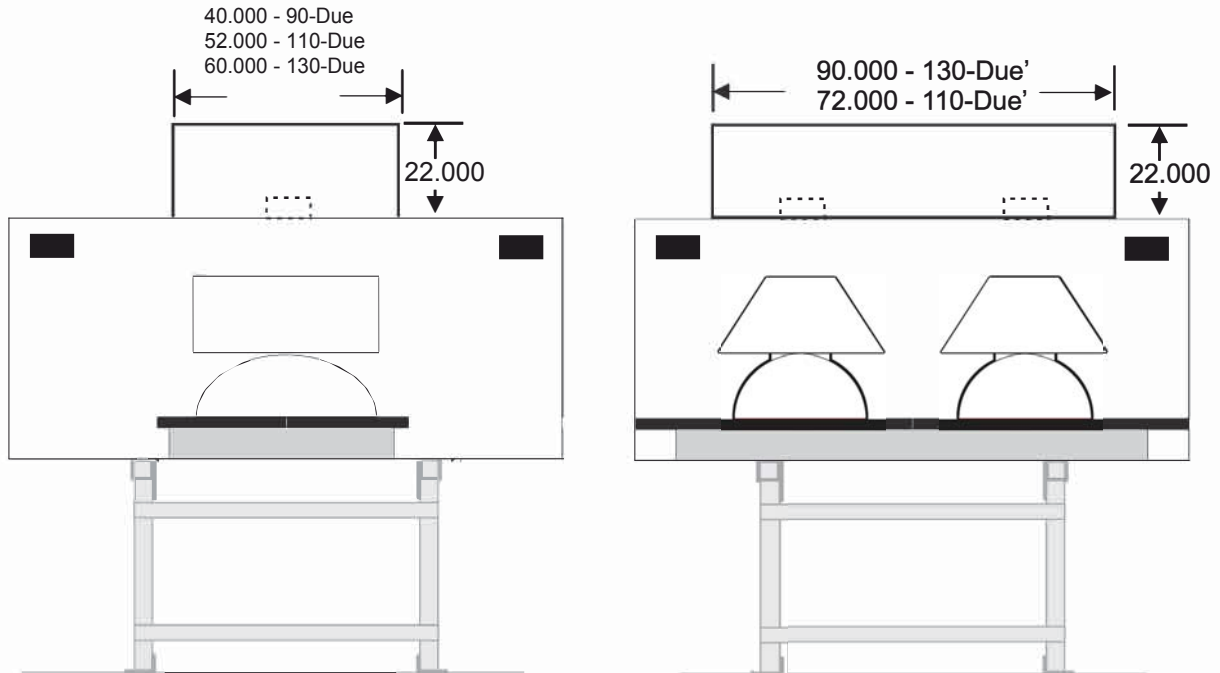

****IT IS NEVER APPROPRIATE TO USE "CLASS A" OR "B VENT" IN ANY PART OF THE EXHAUST SYSTEM EXHAUST SYSTEMS SERVING SOLID-FUEL EQUIPMENT MAY NOT BE COMBINED WITH EXHAUST SYSTEMS SERVING OTHER (NON-SOLID FUEL) COOKING EQUIPMENT**

Grease filters must be placed at the rear of the hood and must be of the steel baffle type (No mesh filters).

Front of hood must be at least 10 inches from the front of the oven face.

Face of the filter must be 42 inches from oven hearth per UMC or 48 inches per NFPA 96

Sides of the hood must extend a min. of 6 inches to either side of the oven door opening.

3 inch min. clearance between the hood and any combustible material.

CLEARANCE INFORMATION FOR FACADES

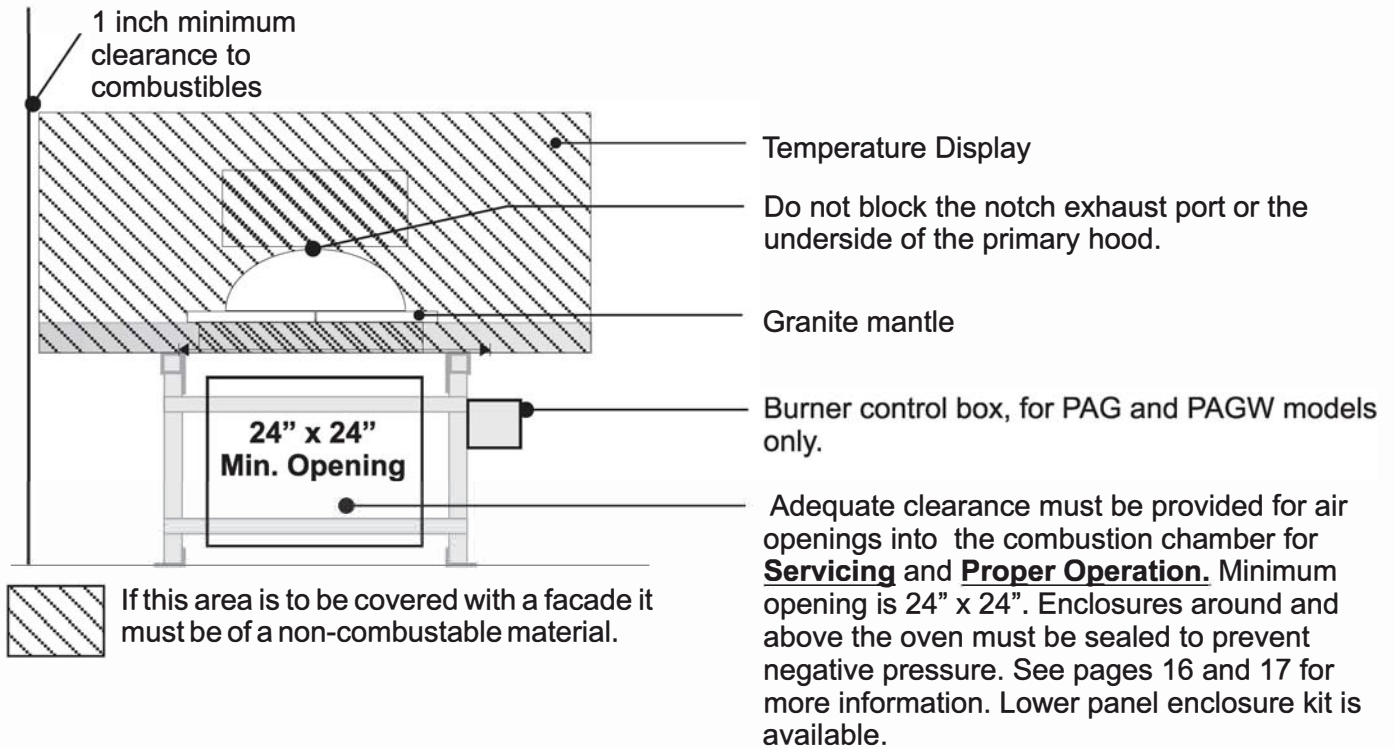
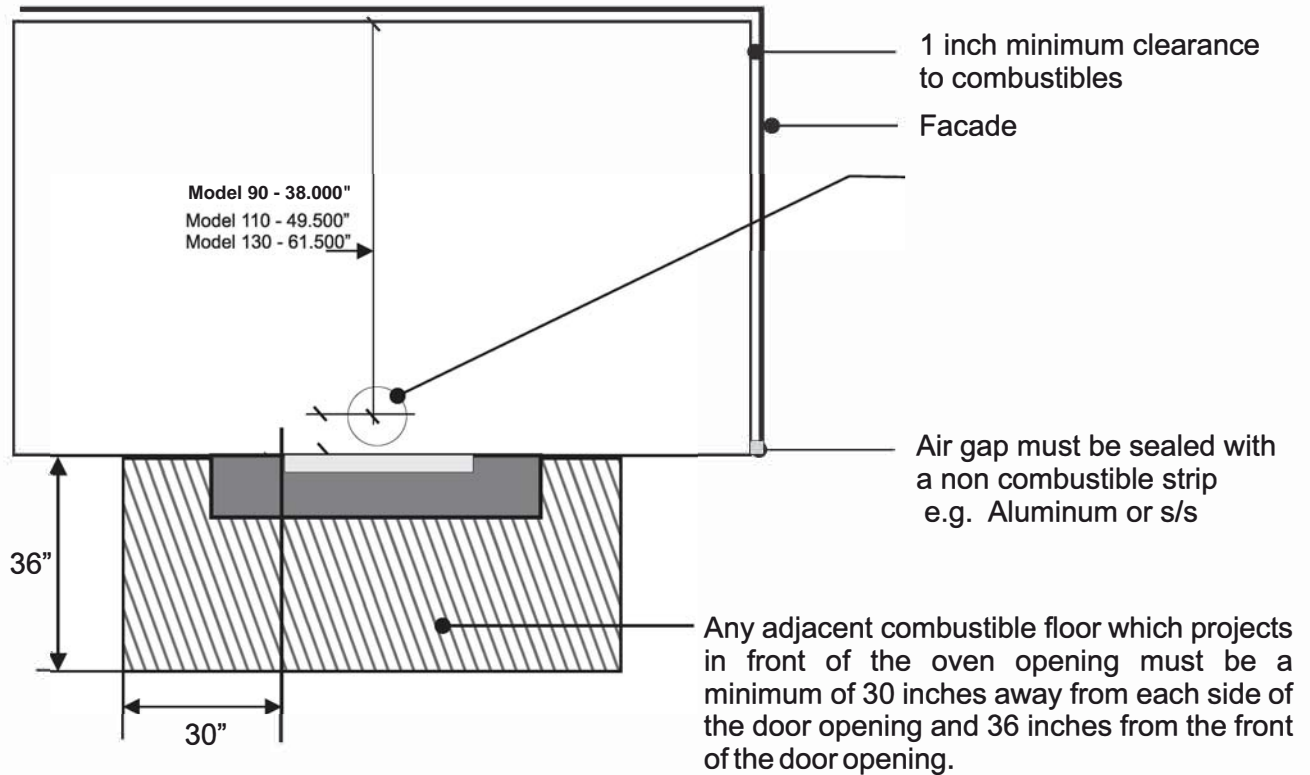

IMPORTANT: PLEASE READ

FOR GAS FIRE OR GAS/WOOD COMBINATION OVENS ONLY

Combustion air intake procedures and installation

Proper installation:

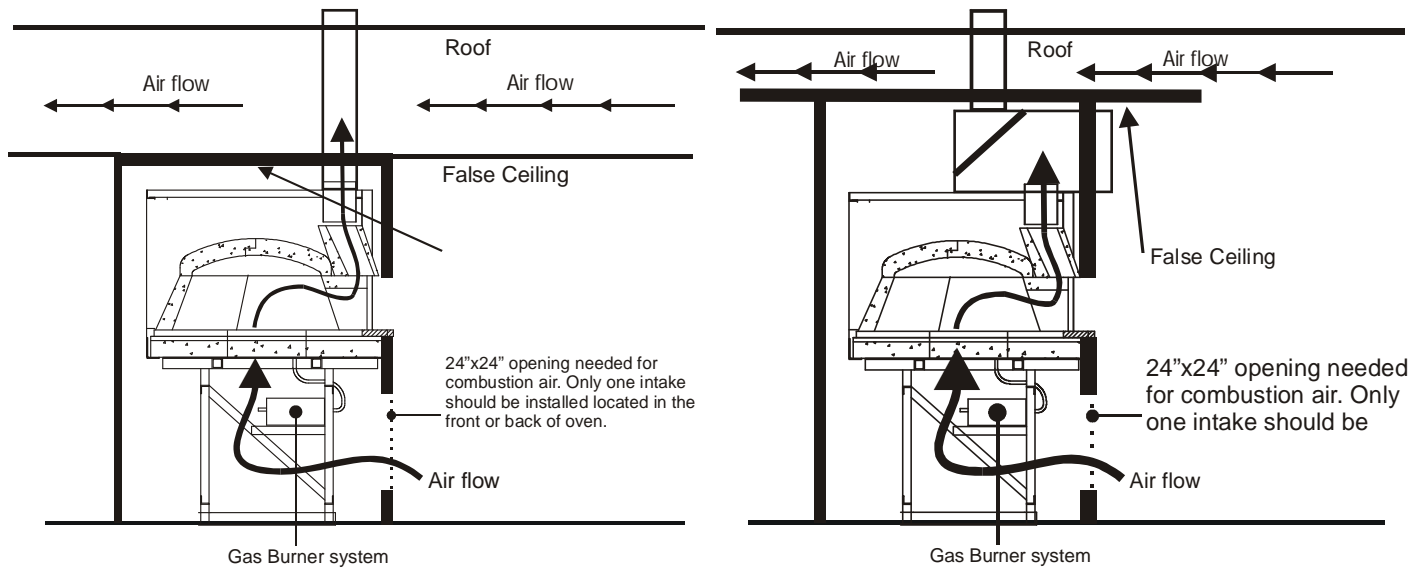

Improper Installation:

1) No air intake opening for burner

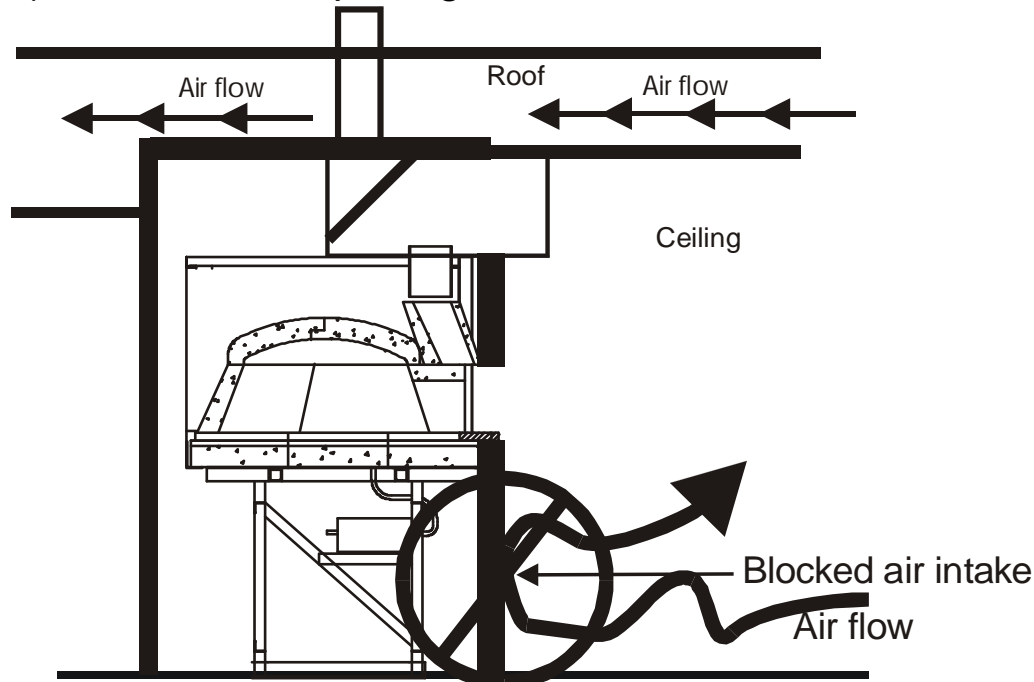

In this case a 24"x24" opening will be needed for proper air combustion.

Improper Installation (cont)

2) Oven is not closed to plenum/attic and is open to HVAC airflow.

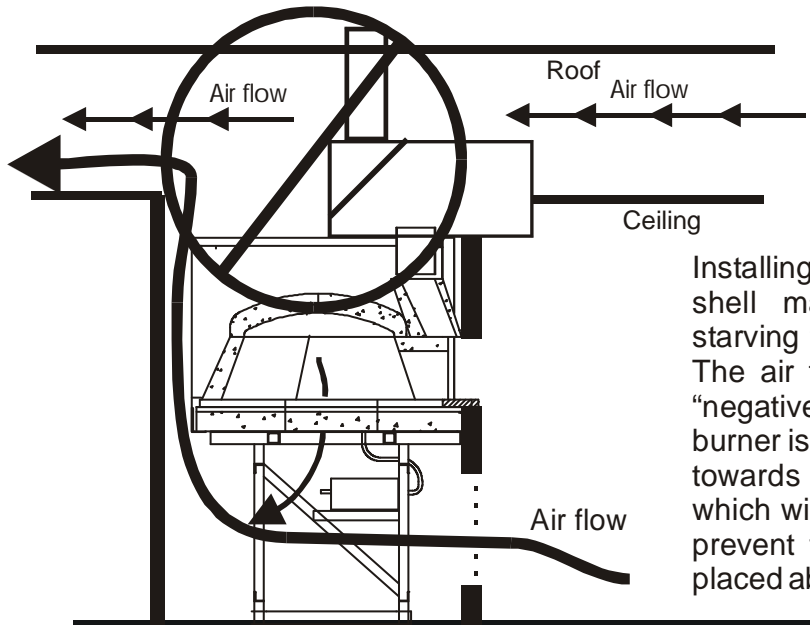

Installing a sealed enclosure around the oven shell may cause improper operation by starving the burner system of combustion air. The air flow which travels above will cause "negative pressure" below where the gas burner is located. The air underneath will travel towards the air flow above creating a suction which will force the gas flame downwards. To prevent this a non-combustible lid must be placed above the oven.

3) Altered airflow from air intake in a separate room with low pressure.

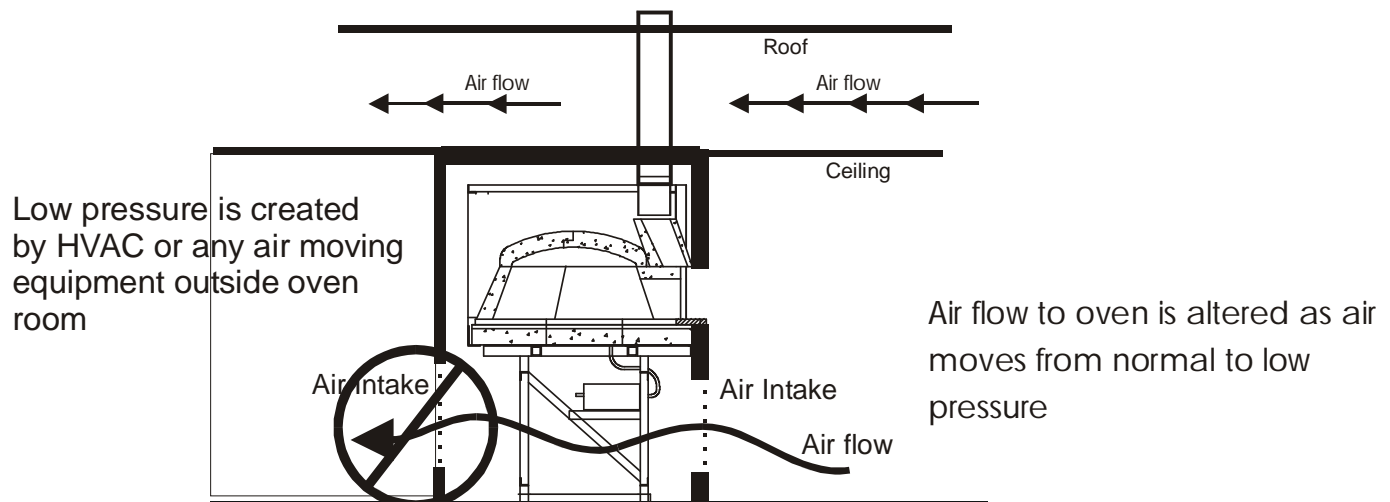

In this case the air intake located on the rear of the oven should be closed.

NOTICE

Expansion cracks, due to the refractory mass, are normal in the front entrance and on any interior surface. This will not effect the performance, efficiency and longevity of the oven in any way.

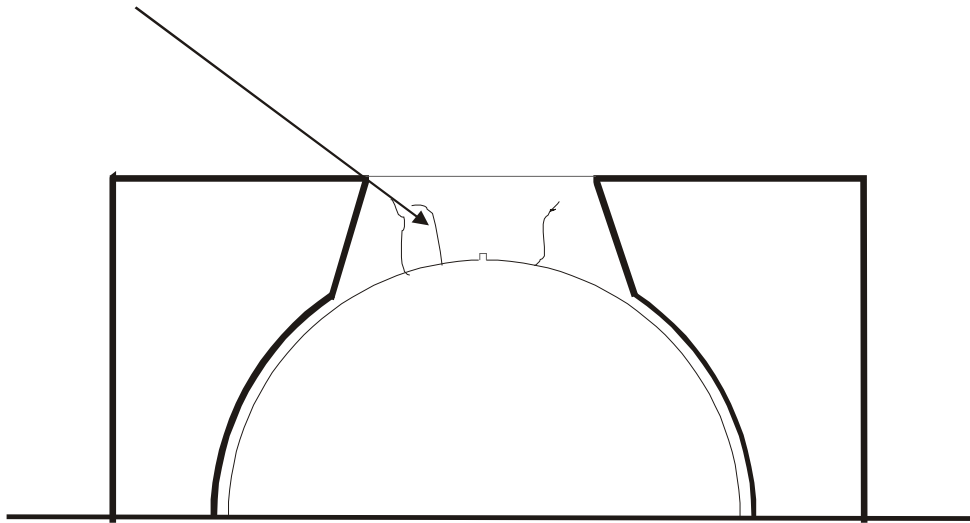

Cut view of inside oven

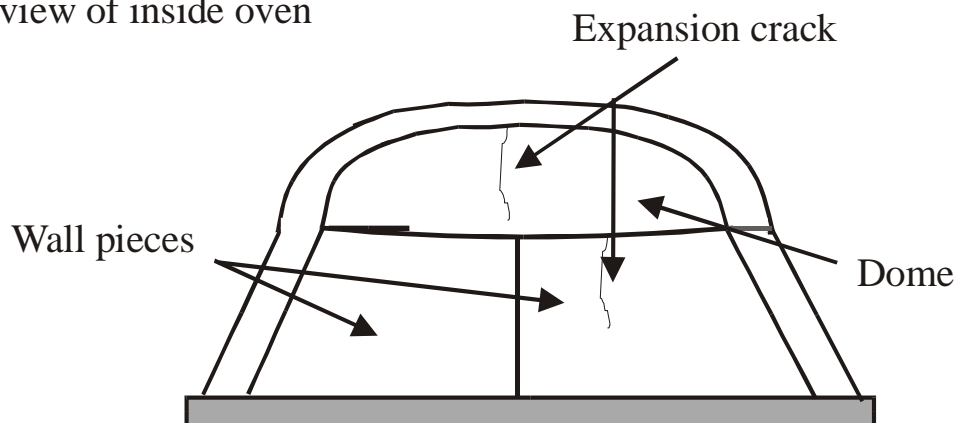

What kind of wood to use?:

Oak, Almond, Walnut, Citrus, Apple, Cherry and most fruit and hard woods.

Moisture Content:

Moisture content should not exceed 15 to 25 percent. Firewood from suppliers should be within this range.

For those of you that have your own orchards, fresh cut wood from live trees will dry to about 20 percent moisture in about six to nine months, assuming that it is out of the weather. Air circulation, exposure of end grain, and lengthwise splitting of larger pieces will accelerate the drying process.

Unit of Measurement:

Firewood is purchased by the cord. A cord of wood is a pile 8ft d x 4ft w x 4ft h. Standard practices recognizes 90 cubic feet of solid wood as the customary. Some suppliers do bundle wood in smaller bags for an extra fee.

Firing Oven:**IMPORTANT NOTE:**

OVEN SHOULD BE CURED FIRST. THIS IS DONE BY LIGHTING TWO SMALL FIRES. ONE FIRE PER DAY FOR ONE HOUR. (THE SMALL FIRE SHOULD JUST TOUCH THE TOP OF THE DOME). THIS SHOULD RELIEVE ALL EXCESS MOISTURE IN THE OVEN.

At first a small amount of kindling should be used. These pieces should range from ½ inch to 1 inch in diameter and 12 to 18 inches in length. Split 2" x 4"s will also work great to start a fire.

Place a fire starter in the middle of the hearth. You can then start to place your kindling on top of the fire starter in a teepee format. You can also use a larger piece of wood, about 2 -3 inches in diameter, as a support for the kindling. Light the fire starter. Once the fire is burning well, you can start to add larger pieces of wood. Note that proper ventilation is needed in order to have a good burning fire, therefore overloading with wood will probably smother the fire.

Have no more than four large pieces of wood in the oven at one time, this depends on the size of the oven. Usually 2-3 inch diameter pieces of wood or the split wood equivalent (A 5-6 inch diameter piece split in two), along with a nice bed of embers is sufficient. The fire should aggressively hit the dome and extend out about 10 to 12 inches each way. After about one hour of firing, the dark soot should start to disappear from the dome of the oven. This is a good indication that the oven is getting hot. After the firing has been burning for an hour or so, move the fire to the side where your pizzas will be placed. This will give extra floor heat to this area. Then you can move the coals back to the opposite end.

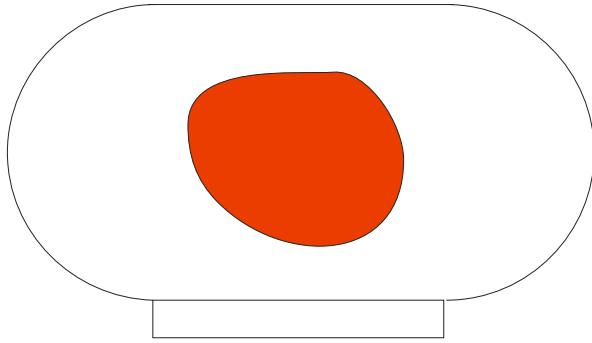
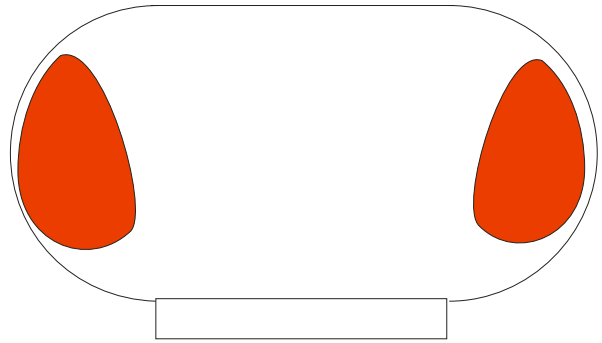
**POSITION 1****POSITION 2**

Try not to over fire the oven. This will not harm the oven but you may get the oven too hot for cooking and may need to wait for the oven to cool down a little.

Larger ovens used in restaurants will heat much faster after the first initial heat up. The large mass needs at least 2-3 days of firing in order for the heat to be fully absorbed into the stone.

Temperature gauge should read at least above 600F for proper baking of pizzas. Thinner pizzas usually require higher temperatures.

When the oven is ready, move the embers to one or both sides. You should always have a flame when baking pizzas. The flame height should be around where the wall and dome pieces meet.