

USA

Instructions for Assembly and Use

USA

F

Instructions de montage et d'utilisation

F

E

Instrucciones para el manejo y uso

E

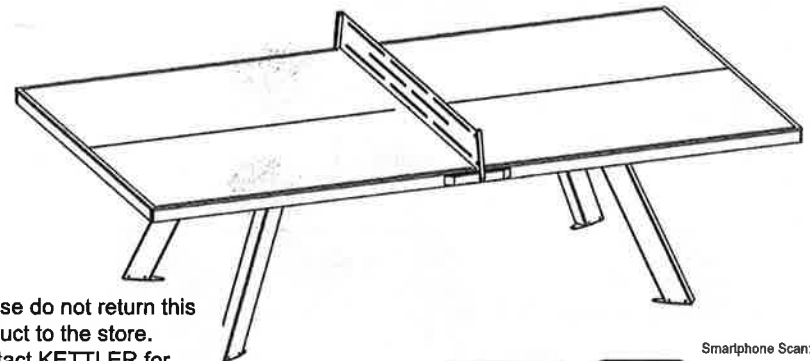
KETTLER EDEN OUTDOOR

Please do not return this product to the store.
Contact KETTLER for parts and service: call toll free 866.804.0440 or send an email to:
parts@kettlerusa.com

MA 244 - v.25.05.16-01

YouTube

Smartphone Scan:



YouTube channel: www.youtube.com/ttservice
Video URL: <http://q-r.to/badsic>

KETTLER International Inc. 1355 London Bridge Road Virginia Beach, VA 23453 USA
www.kettlerusa.com, info@kettlerusa.com

USA

Before starting to assemble the tt-table and before using it for the first time please read the Assembly Instructions and the Information for the User very carefully. They contain important advices for safety when using the table. Please keep the instructions for your information, for maintenance and for ordering spare parts as long as you use the tt-table.

- At least **two adults** have to participate in the assembly of the tt-table which should be carried out on a clean and soft floor.
- Use corresponding **assembly kit** for this installation step.
- Please follow the ABC references for the order of the assembly.
- If there is a **text mark**, please read the explanation on page **III**.
- If there is a **part mark**, please read the information relating to it in the Parts List on page **V**.
- Please use the **tools** as indicated for each of the assembly stages.

Assembly kit



Text mark



Part mark

13

Tool



F

Avant le montage et la première utilisation de la table de ping-pong, lire attentivement les instructions de montage et d'utilisation. Elles comportent des renseignements importants pour votre sécurité sur l'utilisation de la table de ping-pong. Veuillez conserver ces instructions pour votre information, pour l'entretien et la commande de pièces détachées, tant que vous utiliserez la table de ping-pong.

- Le montage de la table de ping-pong nécessite l'intervention de **deux adultes** au moins et doit avoir lieu sur une surface propre et sans aspérités.
- Utilisez le **sachet de montage** correspondant pour la phase de montage.
- Veuillez suivre, lors du montage de la table de ping-pong, les instructions de montage dans l'ordre indiqué : A,B,C, ... etc.
- Les explications des **symboles** se trouvent en page **III**.
- Le détail de la **numérotation** des pièces figure en page **V**.
- Veuillez utiliser les **outils** indiqués pour les différentes étapes du montage.

Sachet de montage



Symboles



Numérotation

13

Outils



E

Antes de empezar a montar la mesa, y antes de usarla por primera vez, por favor leer las instrucciones de manejo y la información para el uso muy cuidadoso. Contienen avisos importantes de seguridad para el uso la mesa. Por favor siga las instrucciones para tu información, para el mantenimiento y para ordenar las partes de más, a lo largo del uso de mesa.

- Cuando **dos adultos** tengan que montar la mesa, deberían llevarlo a cabo en un suelo limpio, y blando.
- Emplee para esta fase del montaje la **bolsa de montaje** correspondiente.
- Sigue las instrucciones de las referencias ABC, para el orden del montaje.
- Si hay una **nota en el texto**, lee la explicación de la página **III**.
- Si hay una **marca a parte**, lee la información relacionada con ella, en la lista en la página **V**.
- Utiliza las **herramientas** como indicamos para cada etapa del manejo.

bolsa de montaje



nota en el texto



marca a parte

13

herramienta



I

MA 244

USA

Text marks for the assembly

- Do not over tighten the nuts of the safety unit **17** so that the red part can still move easily.
- Please do not over tighten the nut **11** so that the tt-table can still be folded and unfolded easily.
- Go back to step "A" and assemble the second table top.
- Go back to step "E" and assemble the second table top.
- Go back to step "G" and assemble the second table top.
- Go back to step "J" and assemble the second table top.
- Please check all the working parts of the table in accordance with the Instructions for use after you have completed assembly. If applicable please take care when removing the coating from the playing surface.

F

Symboles

- Ne pas trop visser les écrous du dispositif de sécurité **17**, afin que la partie rouge puisse bouger facilement.
- Veuillez ne pas visser trop fort l'écrou **11**, afin que la table de ping-pong puisse être ouverte et repliée aisément.
- Retournez à l'étape "A" et montez le second plateau.
- Retournez à l'étape "E" et montez le second plateau.
- Retournez à l'étape "G" et montez le second plateau.
- Retournez à l'étape "J" et montez le second plateau.
- Veuillez, après le montage, vérifier le bon fonctionnement de la table de ping-pong, conformément aux instructions d'utilisation, et enlever avec précaution, s'il y en a un, le film protecteur de la surface de jeu.

E

Pasos de montaje

- No apretar por encima las tuercas de la unidad **17** de seguridad, ya que la parte roja puede permanecer moviéndose fácilmente.
- No apretes la tuerca **11**, ya que la mesa puede permanecer plegada, y desplegarse fácilmente.
- Vuelve al paso "A", y asamblea la segunda parte de la mesa.
- Vuelve al paso "E", y asamblea la segunda parte de la mesa.
- Vuelve al paso "G", y asamblea la segunda parte de la mesa.
- Vuelve al paso "J", y asamblea la segunda parte de la mesa.
- Por favor revise todas las funciones de acuerdo con las instrucciones de montaje, después de haber montado la mesa. Quite cuidadosamente la capa de protección de la parte superior si es necesario.

III

MA 244

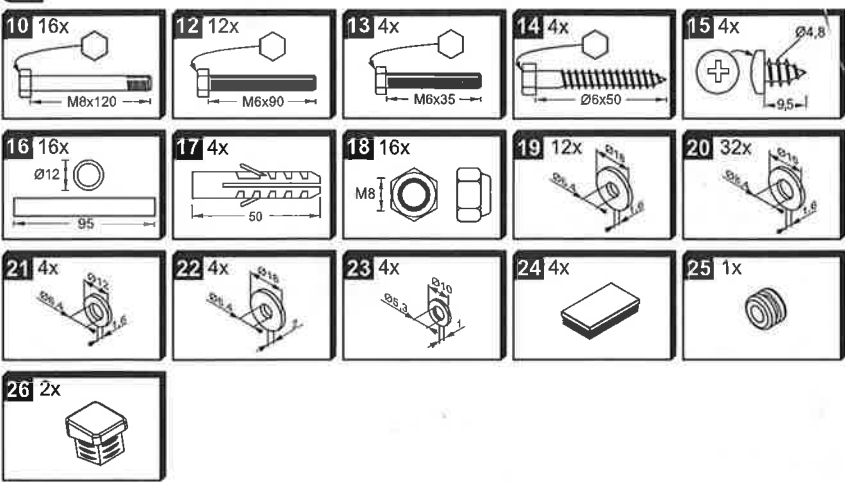
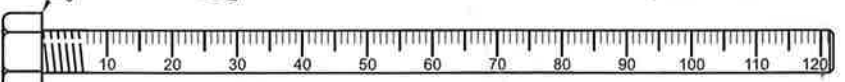
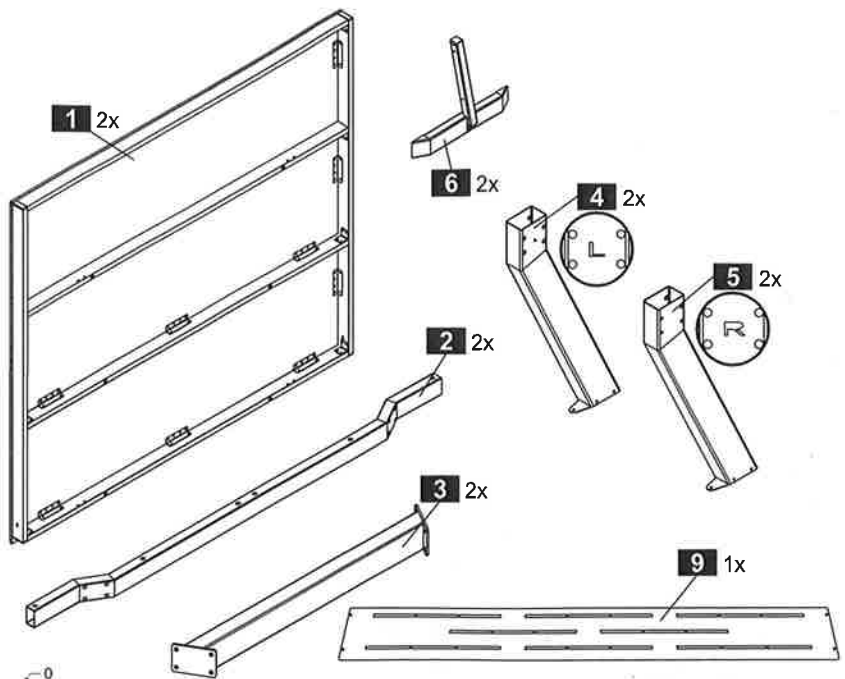

MA 244 - v.25.05.16-01

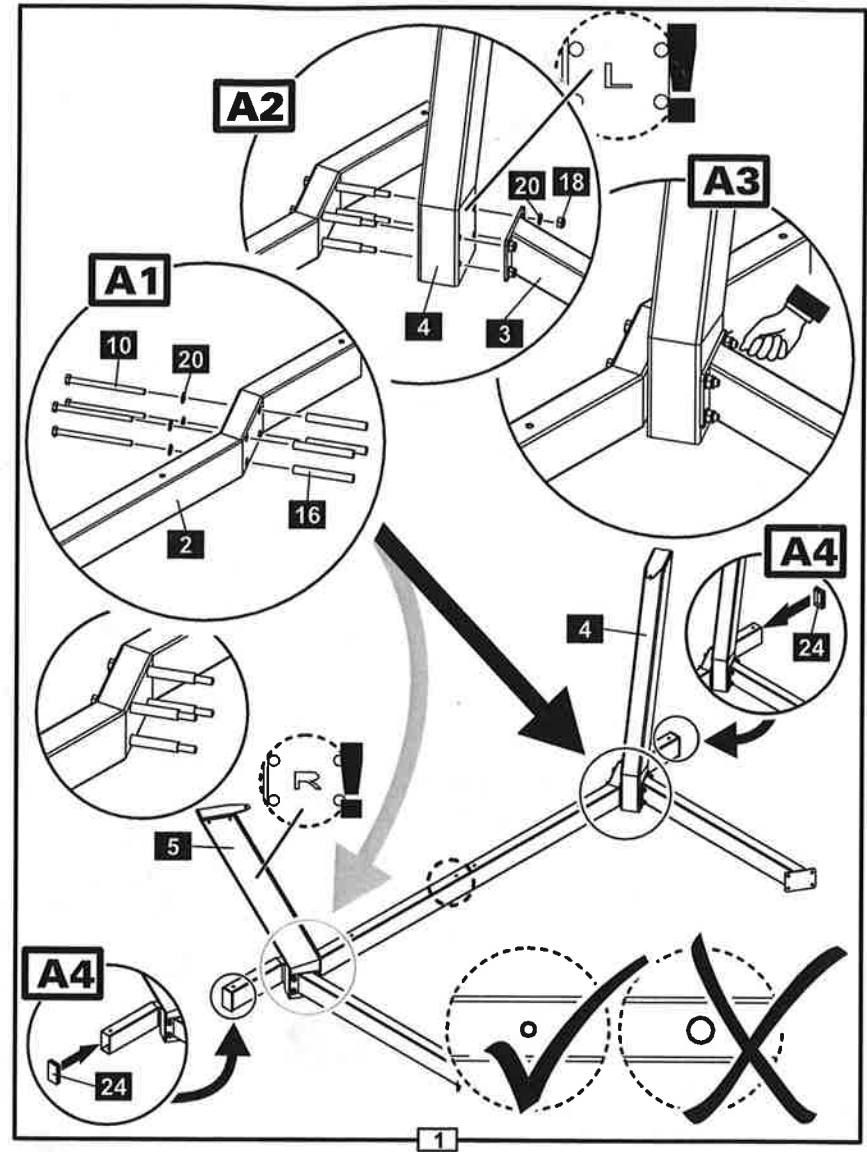
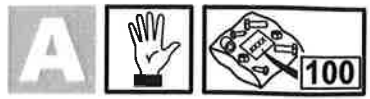

MA 244

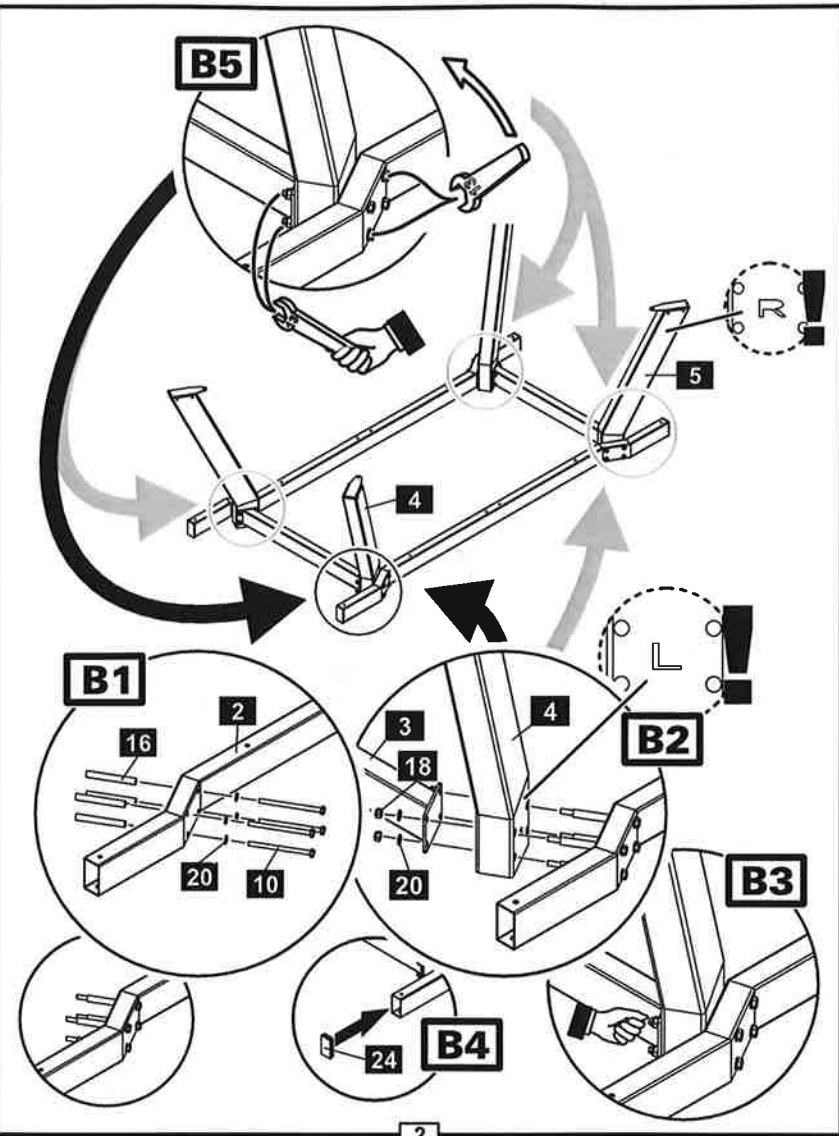
B**C**

2

MA 244

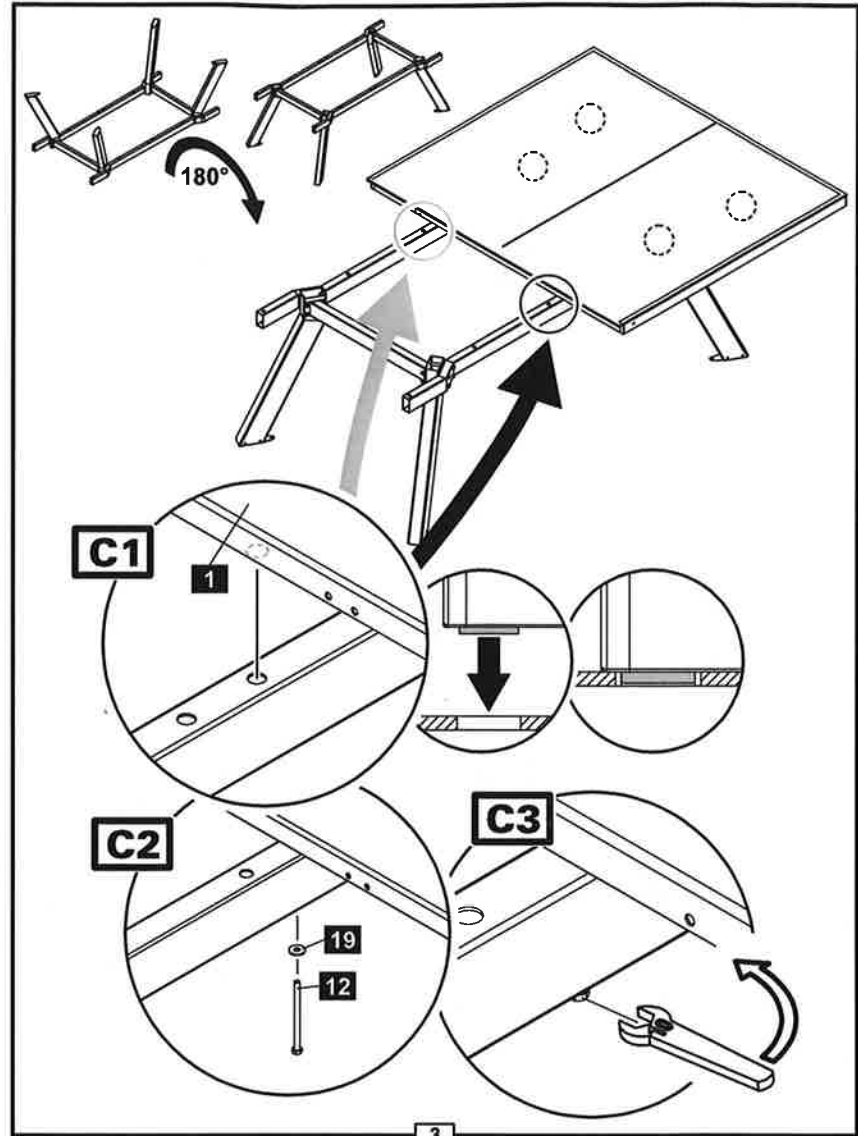

3

MA 244

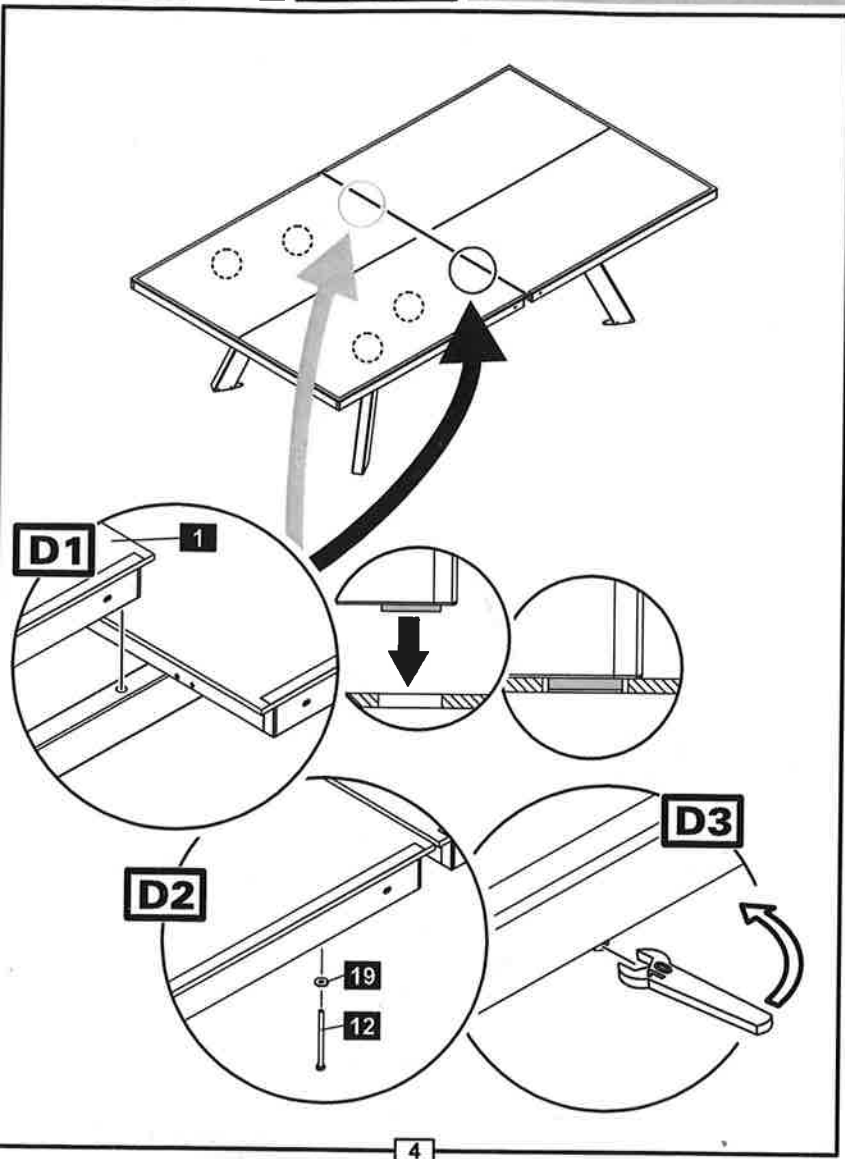
D

MA 244

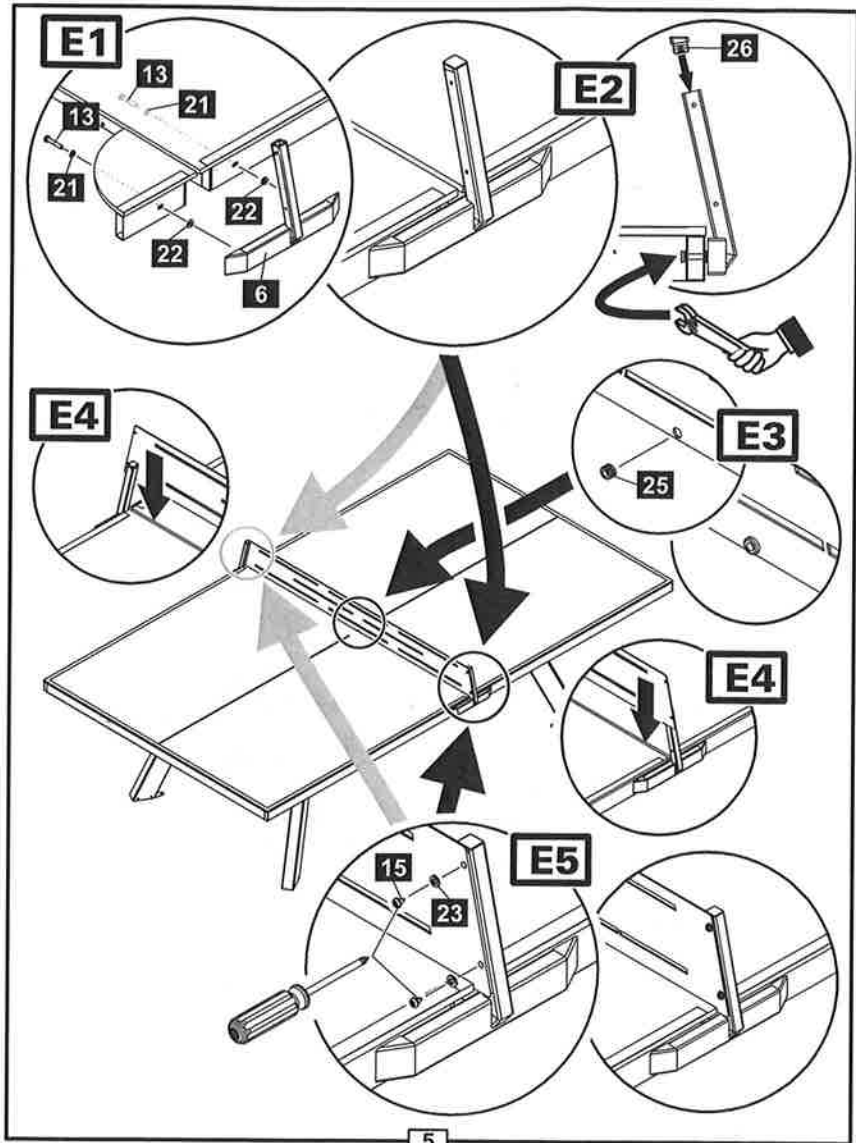
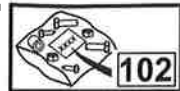
E

MA 244

F

1x



Ø8mm



1x



1x



1x



103

4x

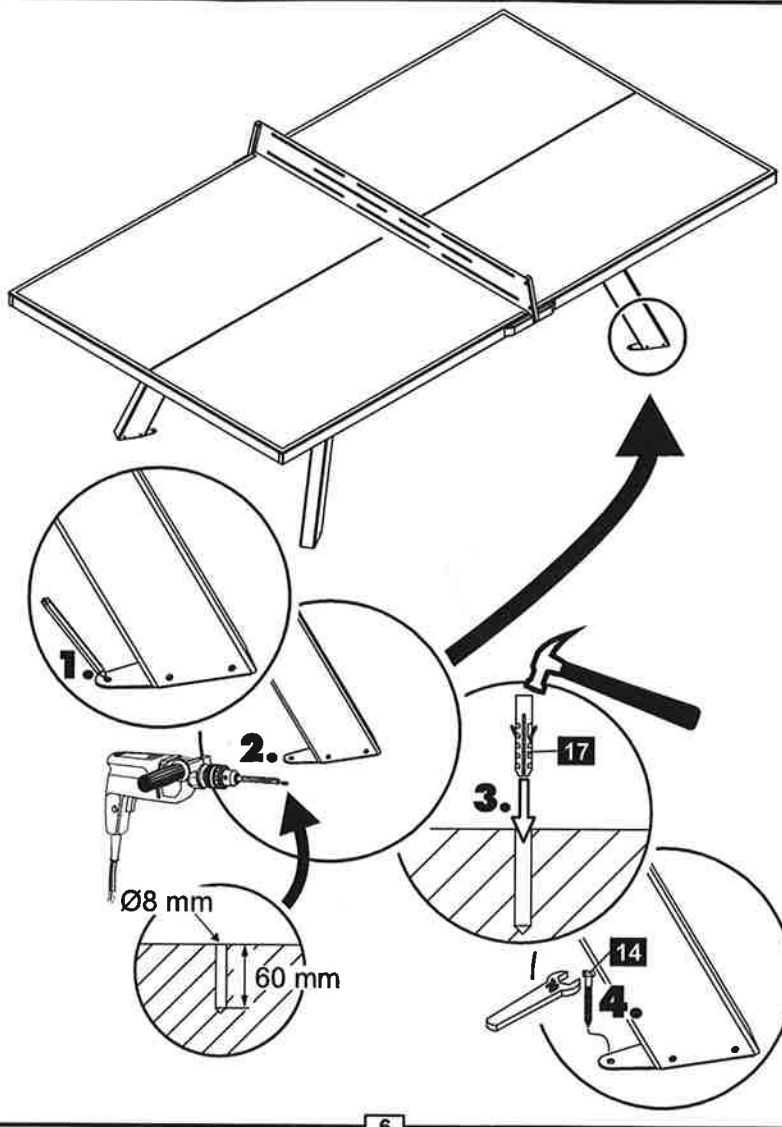

MA 244