



**FOOD EQUIPMENT**

*SERVING THE FOOD INDUSTRY SINCE 1951*

## COUNTERTOP SINGLE AND DOUBLE BULB HEAT LAMP

Item #:39602/ 39601

Model: FW-CN-0736/ FW-CN-0936



- Great for fast food restaurants, snack bars, catering, concession stands and buffets
- Perfect for keeping potato wedges, french fries, chicken or onion rings warm and ready to serve
- CE certified



Authorized Dealer

### Detail Shots



275 Watt  
Infrared Bulbs



Ventilated Reflectors



Comes with a drip tray



One switch per lamp



110-120V  
Electrical connector

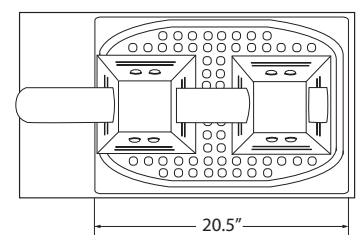
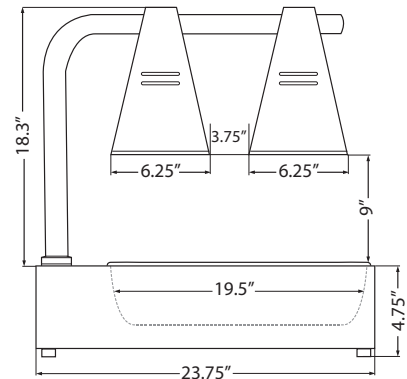
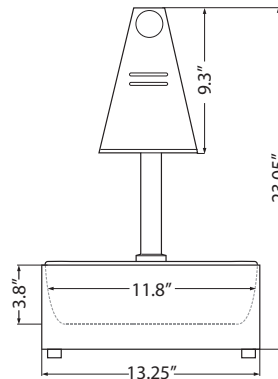
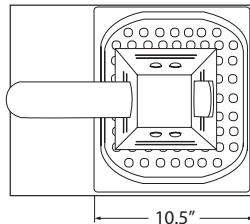
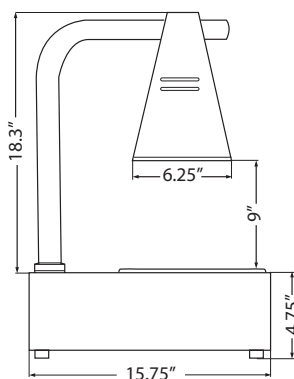
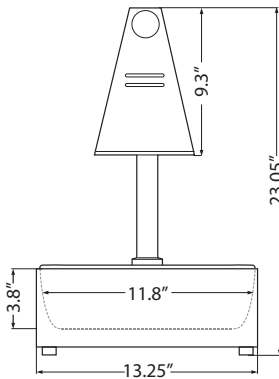

### COUNTERTOP SINGLE BULB HEAT LAMP

ITEM NUMBER	39602
MODEL	FW-CN-0736
INPUT POWER	0.275 kW
ELECTRICAL	110V / 60Hz
NET WEIGHT	6.6 lbs / 3 kg.
PACKAGING WEIGHT	8.4 lbs . / 3.8 kg.
DIMENSIONS (DWH)	15.7" x 13.25" x 23.05" 40 x 33.7 x 58.5 cm
PACKAGING DIMENSIONS	15.6" x 17.7" x 24" 39.6 x 45 x 61 cm

### COUNTERTOP DOUBLE BULB HEAT LAMP

ITEM NUMBER	39601
MODEL	FW- CN-0936
INPUT POWER	0.275 kW
ELECTRICAL	110V / 60Hz
NET WEIGHT	12 lbs. / 5.5 kg.
PACKAGING WEIGHT	14 lbs./ 6.4 kg.
DIMENSIONS (DWH)	23.75" x 13.25" x 23.05" 60.3 x 33.7 x 58.5 cm
PACKAGING DIMENSIONS	15.6" x 25.6" x 24" 39.6 x 65 x 61 cm

## OMCAN INC.

Telephone: 1-800-465-0234  
 Fax: (905) 607-0234  
 E-mail: sales@omcan.com  
 Website: www.omcan.com



Follow us to keep up to date with the latest news and offers

