

R20 Special Order



3
BLADES

20 Qt.



A SALES FEATURES

Vertical Cutter Mixer R20 is designed for processing both large and small quantities of meat, vegetables and smooth textured mousses, as well as for grinding and kneading food product in a minimum of time.

B TECHNICAL FEATURES

Vertical Cutter Mixer R20. Three-Phase. Power 5.5 HP. 2 speeds. Pulse switch. 20 Qt. stainless-steel bowl with 2 handles. Bowl-base blade assembly with 3 detachable smooth blades included. 50 to 300 meals.

Select all the options at the back page, **F** part.

C TECHNICAL DATA

Output power	5.5 HP
Electrical data	3-phase - Plug included
Speeds	1800 & 3600 rpm
Dimensions (HxLxW)	29 15/16" x 24 13/16" x 14 15/16" - Cube: 6.45
Rate of recyclability	95%
Net weight	194 lbs
Nema #	L15-30P
Reference	R 20 - 208 - 240V/60/3

D	Number of meals per service	50 to 300 covers
----------	-----------------------------	------------------

Working quantities per batch	14 lbs
------------------------------	--------

E PRODUCT FEATURES/BENEFITS

MOTOR BASE

- Direct drive induction motor (no belt) for intensive use.
- Power 5.5 HP.
- Stainless steel motor shaft.
- Flat, easy-clean motor base.
- Magnetic safety and motor brake.
- **2 speeds : 1800 & 3600 rpm**
- Pulse function for a better cut precision.

CUTTER FUNCTION

- 20 Qt. stainless-steel bowl with 2 handles for a better grip.
- Central bowl locking system for easy assembly.
- Bowl-base blade assembly with 3 blades to ensure a perfectly uniform consistency, even when processing small quantity.
- Transparent lid to enable user to monitor processing.
- Opening in center of lid for adding liquid or dry ingredients during processing.

INCLUDED ACCESSORIES

- Stainless steel smooth blade assembly (3 blades)

STANDARDS

ETL electrical and sanitation Listed/ cETL (Canada)



R20

F OPTIONS

- Coarse serrated blade assembly (3 blades) for grinding and kneading - Ref 57098
- Fine serrated blade assembly (3 blades) for chopping herbs and spices - Ref 57099

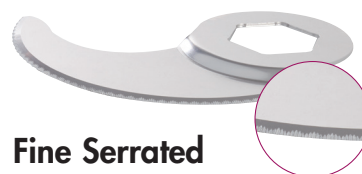

G DRAWINGS & DIMENSIONS

208-240V/60/3
Delivered with cord and plug.

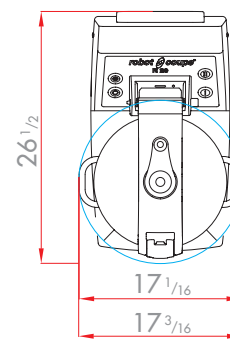
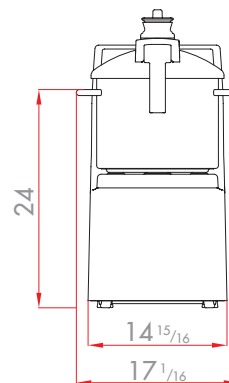
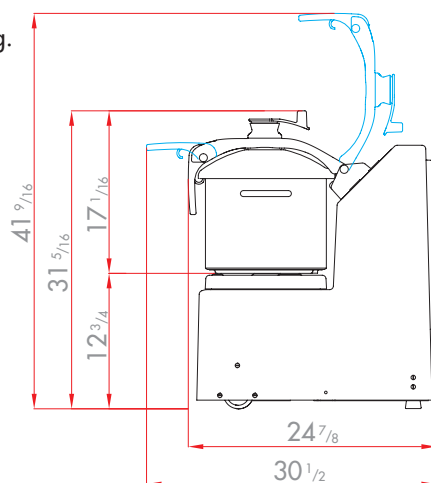
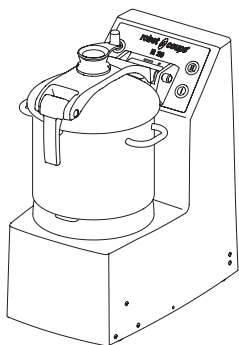

VERTICAL CUTTER MIXERS

robot coupe®

Transparent lid allows observation of the contents being processed and greater control. Dishwasher safe.



Optional coarse serrated blade for grinding and kneading.

Liquids or ingredients can be easily added during processing.



Brushed stainless steel bowl with handles.



Optional fine serrated blade for cutting parsley and emulsifying.

High bowl shaft allows for greater liquid volume processing.

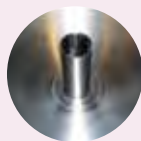

New profile patented blades for an optimal cut quality and absolute consistency.



OPTION: ADDITIONAL 3.5 AND 4 L BOWL AND ACCESSORIES

- Ref. **59430** - 3.5 L Stainless Steel Mini Bowl for R 8
- Ref. **59435** - 4 L Stainless Steel Mini Bowl for R 10 / R 15
- Ref. **27374** - All Stainless Steel 3.5 L Mini Bowl with complete Smooth "S" blade assembly for R 8
- Ref. **27375** - All Stainless Steel 4 L Mini Bowl with complete Smooth "S" blade assembly for R 10 / 15
- Ref. **27107** - 2 Blade Stainless Steel Coarse Serrated "S" Blade Assembly for R8 Special Grinding - Pastry
- Ref. **27106** - 2 Blade Stainless Steel Smooth "S" Blade Assembly for R8
- Ref. **101801** - Coarse serrated blade for R10/R15
- Ref. **101800** - Smooth blade for R10/R15



VERTICAL CUTTER MIXERS

2019 *robot coupe*®

Number of meals
Working quantities per batch

100
400
30 lbs

100
500
34 lbs

200
1000
50 lbs

300
2000
72 lbs

2 SPEEDS 1800 & 3600 rpm

23 L



R 23 T
Three phase

28 L



R 30 T
Three phase

45 L



R 45 T
Three phase

60 L



R 60 T
Three phase

Number of meals
Working quantities per batch

20
150
11 lbs

50
200
13 lbs

50
250
18 lbs

50
300
24 lbs

2 SPEEDS 1800 & 3600 rpm

8 L



R 8
Three phase

11.5 L



R 10
Three phase

15 L



R 15
Three phase

20 L



R 20
Three phase

VERTICAL CUTTER MIXERS