



KITCHEN EQUIPMENT

SERVING THE FOOD INDUSTRY SINCE 1951

11-INCH BLADE SLICER WITH 0.30 HP MOTOR

ITEM: 13624 MODEL: MS-IT-0275-IP



Designed to take up as little space as possible while providing greater cutting capacity

Omcan's 11-inch blade slicer have anodised aluminium alloy body. The high carbon steel blades are hard chromed, with a hollow ground taper for extended sharpening and blade life. This belt driven machine offers exceptional cutting consistency and durability.

The carriage moves smoothly on ball bearings allowing effortless cutting of deli meats and vegetables. Easy to disassemble for quick cleaning. Perfect for low volume operations.

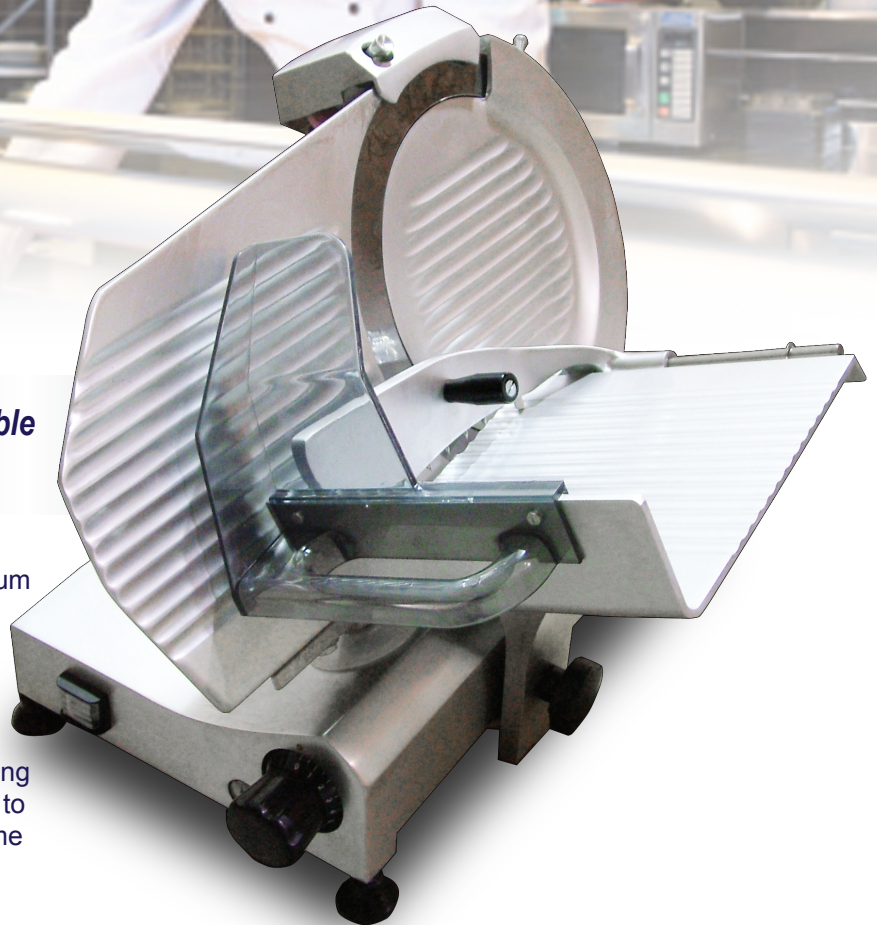

WARRANTY
PARTS AND LABOR

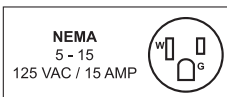

Authorized Dealer

KITCHEN EQUIPMENT

11-INCH BLADE SLICER WITH 0.30 HP MOTOR *MS-IT-0275-IP*



KEY FEATURES

- Perfect for low volume operations
- Have anodised aluminum alloy bodies
- High carbon steel blades are hard chromed, with a hollow ground taper for extended sharpening and blade life
- Exceptional cutting consistency and durability
- Carriage moves smoothly on ball bearings allowing effortless cutting of deli meats and vegetables
- Easy to disassemble for quick cleaning

TECHNICAL SPECIFICATION

ITEM NUMBER	13624
MODEL	MS-IT-0275-IP
BLADE SIZE	11" / 275 mm
CUT THICKNESS	0 - 15 mm
CUTTING SIZE	8.66" x 8.66" / 220 x 220 mm
POWER	0.30 HP / 0.22 kW
CHEESE SLICING [^]	☐☐☐
SLICING VOLUME*	30 mins.
RPM	300 / 0.22 kW
ELECTRICAL	110V / 60 Hz / 1 Ph
NET WEIGHT	40 lbs. / 18 kg.
GROSS WEIGHT	42 lbs. / 19 kg.
DIMENSIONS (WDH)	24.40" x 17.32" x 15.35" 619.76 x 439.9 x 389.89 mm
GROSS DIMENSIONS	22" x 19" x 18" 558.8 x 482.6 x 457.2 mm

TECHNICAL DRAWINGS AND DIMENSIONS

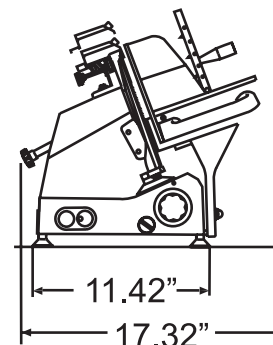
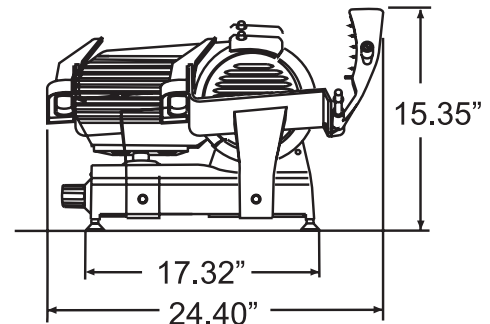

[^]CHEESE SLICING RATINGS: NOT RECOMMENDED (0 bars), POOR (1 bar), AVERAGE (2 bars), GOOD (3 bars), EXCELLENT (4 bars)

*Results may vary due to product consistency and temperature.



WARRANTY
PARTS AND LABOR

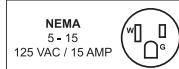

OMCAN INC.

Telephone: 1-800-465-0234

Fax: (905) 607-0234

Email: sales@omcan.com

Website: www.omcan.com



Follow us to keep up to date with the latest news and offers



2016.E.O.E