

NDC-48-CG

REFRIGERATED CURVED GLASS DISPLAY CASE

Ideal for restaurants, cafés, and bakeries

NEW AIR

REFRIGERATION



FEATURES



LED lighting under each shelf for superior product display



Double tempered glass

Air ducts on 3 sides to remove condensation around glass

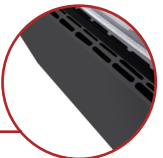

Sliding doors



Black-brushed stainless steel

2 adjustable glass shelves



4 casters (2 with brakes)

- ✓ Automatic defrost
- ✓ Digital controller and LED display
- ✓ LED lighting around the interior of the cabinet
- ✓ On & off switch

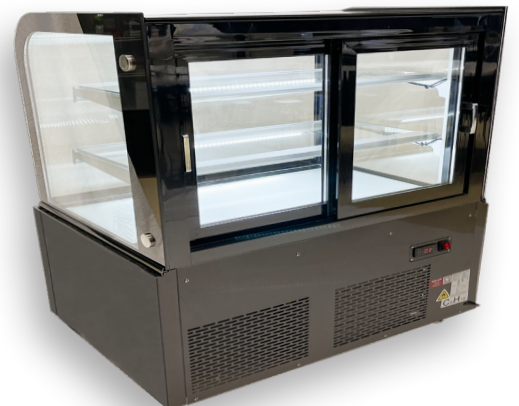

SPECIFICATIONS

| | |
|-------------------------------|--|
| Capacity (Cubic Feet) | 13.06 |
| Capacity (Litres) | 370 |
| Exterior Unit Dimensions (in) | 48.75" (w) x 27" (d) x 47.5" (h) |
| Packing Dimensions (in) | 51.75" (w) x 30" (d) x 51.25" (h) |
| Interior Unit Dimensions (in) | 43.5" (w) x 23" (d) x 25.5" (h) |
| Net/Gross Weight (lb) | 342 / 415 |
| Swivel Casters | 4 (including 2 with brakes) |
| Doors | 2 |
| Adjustable Shelves | 2 |
| Shelf Dimensions (in) | 43.5" (w) x 12.5" (d) (top) 43.5" (w) x 14.75" (d) (middle) |
| Shelf Capacity (lb) | 22 |
| Temperature | 2°C to 12°C |
| Ambient Temperature | ≤30°C |
| Ambient Humidity | ≤55% |
| Refrigerant (CFC-Free) | R290 |
| Input Power (W) | 420 |
| Voltage (V) | 120V / 60Hz |
| Amperage (A) | 4.5 |
| Plug Type | NEMA 5-15p |

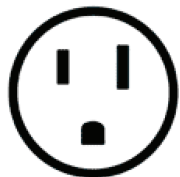
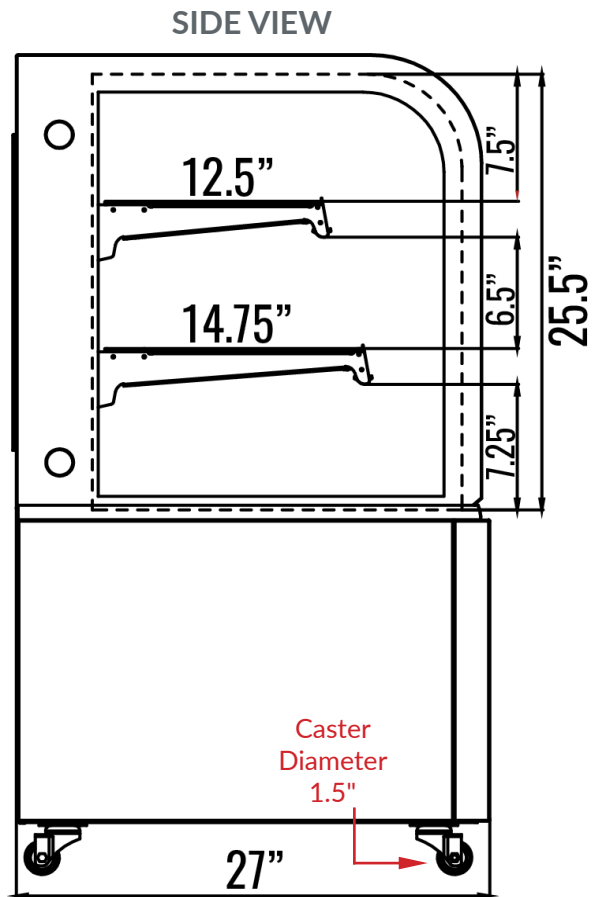

NEMA 5-15P



Intertek

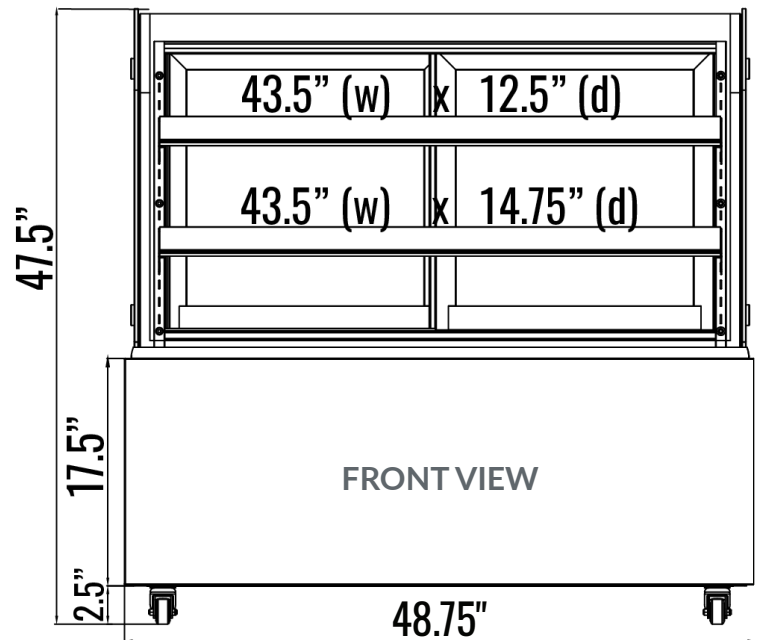
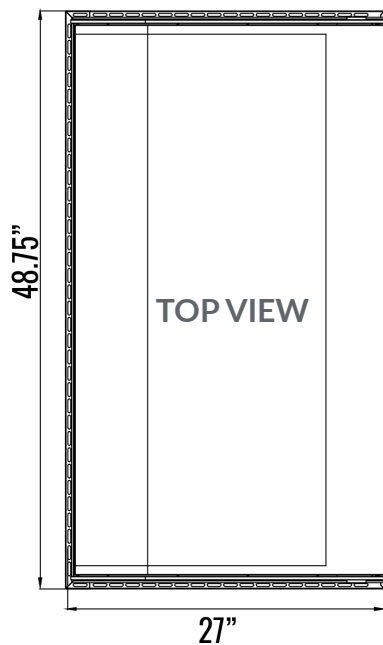

CUSTOMER SUPPORT



We're on social media!

1.800.567.3620



www.newairrefrigeration.ca

MORE PRODUCTS!



Design and specifications can change without prior notice for product improvement