



MODELS

KGV-MR-(2, 3, 4, 5, 6)-R

**HIGH VOLUME GRAB-N-GO CASE
FOR REMOTE CONDENSING UNIT**

CASE HOLDS 33°F TO 40°F • FORCED AIR REFRIGERATION
FRONT & REAR LOADING • LED LIGHTING IN CANOPY AND UNDER SHELVES
CASES CAN BE MULTIPLEXED



AUTODESK®
REVIT®

SELF CONTAINED	Model	Number of Doors	O.A. Length (inches)	Volume FT ³	Total Amps	BTUS	Weight lbs		Crate Size (inches)		
							No Crate	With Crate	L"	W"	H"
	KGV-MR-2-R	2 x 23-1/2	51.5	37.63	2.61	3345	639	847	54	39	85
	KGV-MR-3-R	3 x 23-1/2	75.4	56.37	3.45	4430	899	1166	78	39	85
	KGV-MR-4-R	4 x 23-1/2	99.4	75.26	5.22	6811	1278	1694	104	36	85
	KGV-MR-5-R	5 x 23-1/2	123.2	94	6.06	7795	1538	2013	126	36	85
	KGV-MR-6-R	6 x 23-1/2	147	112.73	6.9	9397	1798	2332	150	36	85

* Note for other lengths please contact MVP

STANDARD FEATURES

- Silver colored PVC coated steel front panel
- CFC free injected foam insulation
- PVC coated steel gray interior
- Black steel kick plate
- Foamed polystyrene black end panels
- Height adjustable shelves can be tilted
- Back doors for rear loading
- Product stops on all shelves
- Temperature and defrost regulated by a digital controller
- Levelling feet

OPTIONAL FEATURES

- Other colors available
- Stainless steel exterior and / or interior
- Additional shelves
- Price tag molding
- Product dividers
- Joining Kit
- Partition

WARRANTY

One year parts and labor with an additional four years on the compressor (part only)

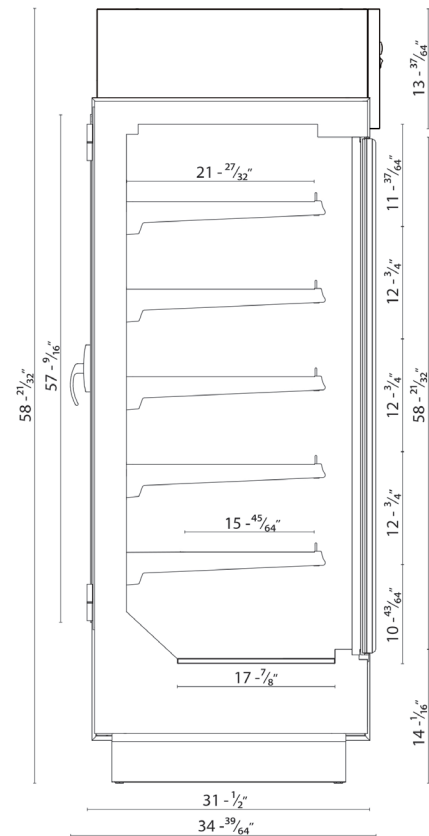

NOTE

These cases are engineered to operate in locations not exceeding 75°F and 55% R.H. These cases are designed to operate using R404a refrigerant. Alternate refrigerants available by special order. O.A. length includes (2) ends at 1-7/8" each. Ventilation grills at front and back cannot be blocked. B.T.U.'s are calculated at 14°F (evaporator) and 90°F (ambient). Floor drain must be provided. Remote cases are provided with an expansion valve and a liquid solenoid for pump down cycle. Cases must be hard wired – no plugs.



MODELS

KGV-MO-(2, 3, 4, 5, 6)-R

**HIGH VOLUME GRAB-N-GO CASE
FOR REMOTE CONDENSING UNIT**

CASE HOLDS 33°F TO 40°F • FORCED AIR REFRIGERATION
LED LIGHTING IN CANOPY AND UNDER SHELVES
CASES CAN BE MULTIPLEXED



Intertek



Intertek



AUTODESK[®]
REVIT[®]

SELF CONTAINED	Model	Number of Doors	O.A. Length (inches)	Volume FT ³	Total Amps	BTUS	Weight lbs		Crate Size (inches)		
							No Crate	With Crate	L"	W"	H"
	KGV-MO-2-R	2 x 23-1/2	51-1/2	35.66	1.4	10458	456	661	54	36	85
	KGV-MO-3-R	3 x 23-1/2	75-3/8	53.41	2	15542	632	902	78	36	85
	KGV-MO-4-R	4 x 23-1/2	99-3/8	71.31	2.8	18436	912	1332	104	36	85
	KGV-MO-5-R	5 x 23-1/2	123-1/8	89.07	3.4	22861	1088	1563	126	36	85
	KGV-MO-6-R	6 x 23-1/2	147	106.82	4	27287	1264	1804	150	36	85

* Note for other lengths please contact MVP

STANDARD FEATURES

- Silver colored PVC coated steel front panel
- CFC free injected foam insulation
- PVC coated steel gray interior
- Black steel kick plate
- Foamed polystyrene black end panels
- Height adjustable shelves can be tilted
- Product stops on all shelves
- Temperature and defrost regulated by a digital controller
- Levelling feet

OPTIONAL FEATURES

- Other colors available
- Stainless steel exterior and / or interior
- Additional shelves
- Price tag molding
- Product dividers
- Joining Kit
- Partition

WARRANTY

One year parts and labor with an additional four years on the compressor (part only)

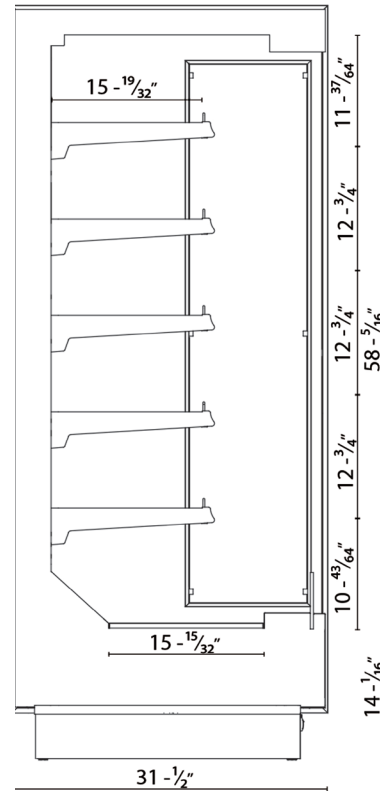

NOTE

These cases are engineered to operate in locations not exceeding 75°F and 55% R.H. These cases are designed to operate using R404a refrigerant. Alternate refrigerants available by special order. O.A. length includes (2) ends at 1-7/8" each. Ventilation grills at front and back cannot be blocked. B.T.U.'s are calculated at 14°F (evaporator) and 90°F (ambient). Floor drain must be provided. Remote cases are provided with an expansion valve and a liquid solenoid for pump down cycle. Cases must be hard wired – no plugs.



MODELS

KGV-MD-(2, 3, 4, 5, 6)-R

**HIGH VOLUME GRAB-N-GO CASE
FOR REMOTE CONDENSING UNIT**

CASE HOLDS 33°F TO 40°F • FORCED AIR REFRIGERATION • FRONT LOADING
LED LIGHTING IN CANOPY AND UNDER SHELVES
CASES CAN BE MULTIPLEXED



AUTODESK®
REVIT®

REMOTE	Model	Number of Doors	O.A. Length (inches)	Volume FT ³	Total Amps	BTUS	Weight lbs		Crate Size (inches)		
							No Crate	With Crate	L"	W"	H"
	KGV-MD-2-R	2 x 23-1/2	51.5	37.63	1.43	3345	555	763	54	37	85
	KGV-MD-3-R	3 x 23-1/2	75.4	56.37	2.19	4430	773	1040	78	36	85
	KGV-MD-4-R	4 x 23-1/2	99.4	75.26	2.86	6811	1110	1526	104	36	85
	KGV-MD-5-R	5 x 23-1/2	123.2	94	3.62	7795	1328	1803	126	36	85
	KGV-MD-6-R	6 x 23-1/2	147	112.73	4.38	9397	1546	3052	150	36	85

* Note for other lengths please contact MVP

STANDARD FEATURES

- Silver colored PVC coated steel front panel
- CFC free injected foam insulation
- PVC coated steel gray interior
- Black steel kick plate
- Foamed polystyrene black end panels
- Height adjustable shelves can be tilted
- Product stops on all shelves
- Temperature and defrost regulated by a digital controller
- Levelling feet

OPTIONAL FEATURES

- Other colors available
- Stainless steel exterior and / or interior
- Additional shelves
- Price tag molding
- Product dividers
- Joining Kit
- Partition

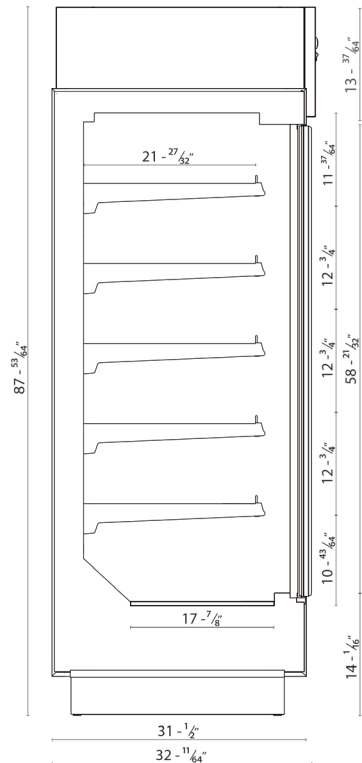

WARRANTY

One year parts and labor with an additional four years on the compressor (part only)

NOTE

These cases are engineered to operate in locations not exceeding 75°F and 55% R.H. These cases are designed to operate using R404a refrigerant. Alternate refrigerants available by special order. O.A. length includes (2) ends at 1-7/8" each. Ventilation grills at front and back cannot be blocked. B.T.U.'s are calculated at 14°F (evaporator) and 90°F (ambient). Floor drain must be provided with an expansion valve and a liquid solenoid for pump down cycle. Cases must be hard wired – no plugs.



Tel: 786.600.4687 / Toll Free: 844.218.8477

Fax: 786.661.4100



Tel: 514.737.9701 / Toll Free: 888.275.4538

Fax: 514.342.3854 / toll free: 877.453.8832

sales@mvpgroupcorp.com / mvpgroupcorp.com



MODELS

KGV-MR-(2, 3, 4, 5, 6)-S

**HIGH VOLUME
GRAB-N-GO CASE**

CASE HOLDS 33°F TO 40°F • FORCED AIR REFRIGERATION • SELF-CONTAINED
FRONT & REAR LOADING • LED LIGHTING IN CANOPY AND UNDER SHELVES
CASES CAN BE MULTIPLEXED



AUTODESK®
REVIT®

SELF CONTAINED	Model	Number of doors	O.A. Length (inches)	Volume FT ³	Electrical 115 Volts				Weight lbs		Crate Size (inches)			
					Front	Compressor		LIGHTS Fans HTRS	Total Amps	No Crate	With Crate	L"	W"	H"
						H.P	F.L.A							
	KGV-MR-2-S	2 x 23-1/2	51.5	37.63	5/8	8.9	3.51	12.41	704	864	54	37	95	
	KGV-MR-3-S	3 x 23-1/2	75.4	56.37	5/8	8.9	4.35	13.25	964	1204	78	37	95	
	KGV-MR-4-S	4 x 23-1/2	99.4	75.26	2 x 5/8	2 x 8.9	3.5 + 3.5	12.4 + 12.4	1408	1724	104	36	95	
	KGV-MR-5-S	5 x 23-1/2	123.2	94	2 x 5/8	2 x 8.9	3.5 + 4.4	12.4 + 13.3	1668	2008	126	36	95	
	KGV-MR-6-S	6 x 23-1/2	147	112.73	2 x 5/8	2 x 8.9	4.4 + 4.4	13.3 + 13.3	1928	2408	150	36	95	

* Note for other lengths, please contact MVP

STANDARD FEATURES

- Back doors for rear loading
- Silver colored PVC coated steel front panel
- CFC free injected foam insulation
- PVC coated steel gray interior
- Black steel kick plate
- Foamed polystyrene black end panels
- Height adjustable shelves can be tilted
- Product stops on all shelves
- Temperature and defrost regulated by a digital controller
- Levelling feet

OPTIONAL FEATURES

- Other colors available
- Stainless steel exterior and / or interior
- Additional shelves
- Price tag molding
- Product dividers
- Joining Kit
- Partition

WARRANTY

One year parts and labor with an additional four years on the compressor (part only)

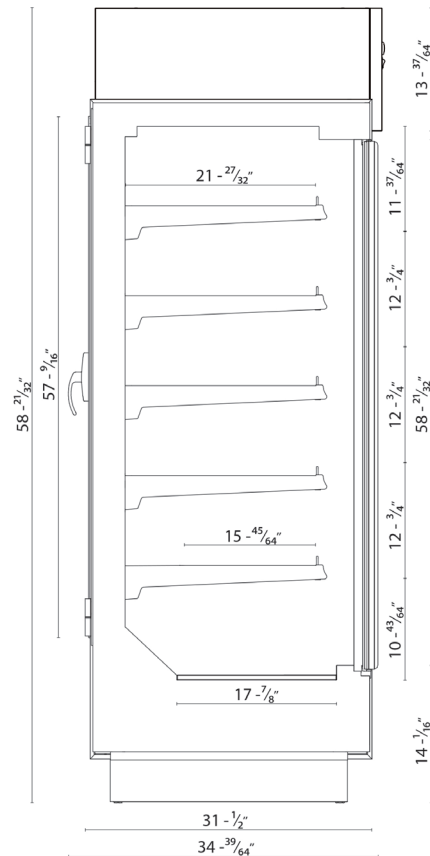

NOTE

These cases are engineered to operate in locations not exceeding 75°F and 55% R.H. These cases are designed to operate using R404a refrigerant. Alternate refrigerants available by special order. O.A. length includes (2) ends at 1-7/8" each. Ventilation grills at front and back cannot be blocked. Floor drain must be provided. Cases must be hard wired – no plugs.



MODELS

KGV-MD-(2, 3, 4, 5, 6)-S

**HIGH VOLUME
GRAB-N-GO CASE**

CASE HOLDS 33°F TO 40°F • FORCED AIR REFRIGERATION • SELF CONTAINED
FRONT LOADING • LED LIGHTING IN CANOPY AND UNDER SHELVES
CASES CAN BE MULTIPLEXED



AUTODESK®
REVIT®

SELF CONTAINED	Model	Number of Doors	O.A. Length (inches)	Volume FT ³	Electrical 115 Volts				Weight lbs		Crate Size (inches)			
					Front	Compressor		LIGHTS Fans HTRS	Total Amps	No Crate	With Crate	L"	W"	H"
						H.P	F.L.A							
	KGV-MD-2-S	2 x 23-1/2	51.5	37.63	5/8	8.9	2.3	11.23	622	780	54	36	95	
	KGV-MD-3-S	3 x 23-1/2	75.4	56.37	5/8	8.9	3.1	12	840	1080	78	36	95	
	KGV-MD-4-S	4 x 23-1/2	99.4	75.26	2 x 5/8	2 x 8.9	2.3 + 2.3	11.3 + 11.3	1244	560	104	36	95	
	KGV-MD-5-S	5 x 23-1/2	123.2	94	2 x 5/8	2 x 8.9	2.3 + 3.1	11.3 + 12	1462	1860	126	36	95	
	KGV-MD-6-S	6 x 23-1/2	147	112.73	2 x 5/8	2 x 8.9	3.1 + 3.1	12 + 12	1680	2160	150	36	95	

*Note for other lengths, please contact MVP

STANDARD FEATURES

- Silver colored PVC coated steel front panel
- CFC free injected foam insulation
- PVC coated steel gray interior
- Black steel kick plate
- Foamed polystyrene black end panels
- Height adjustable shelves can be tilted
- Product stops on all shelves
- Temperature and defrost regulated by a digital controller
- Levelling feet

OPTIONAL FEATURES

- Other colors available
- Stainless steel exterior and / or interior
- Additional shelves
- Price tag molding
- Product dividers
- Joining Kit
- Partition

WARRANTY

One year parts and labor with an additional four years on the compressor (part only)

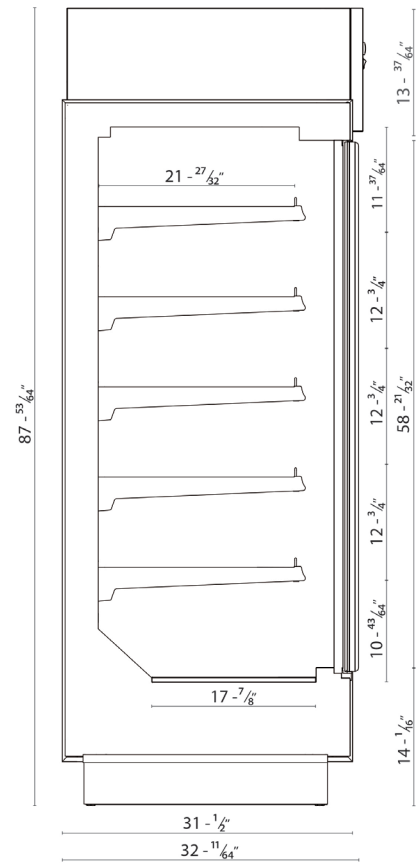

NOTE

These cases are engineered to operate in locations not exceeding 75°F and 55% R.H. These cases are designed to operate using R404a refrigerant. Alternate refrigerants available by special order. O.A. length includes (2) ends at 1-7/8" each. Ventilation grills at front and back cannot be blocked. Floor drain must be provided. Cases must be hard-wired-no plugs.