

**Trio Ventless Oven**

**MODEL: RPO3**



**FEATURES & BENEFITS**

- Fast Even Baking of Pizzas, Wings, and more
- Stainless Steel Constructed
- Programmable Touchscreen Control
- Full View Glass Door
- Fully Illuminated
- Easy Open & Close Drop Down Door
- Stackable
- Capacity—(3) 18" (457 mm) Pizzas
- Fast Recovery
- Ventless Convection Baking, Hood Not Required
- Jet Air Exclusive Reversing Fan System
- Temperature up to 600°F (316°C)
- Direct Baking on Nickel Coated Perforated Decks (Helps with Heat Retention)
- Designed for Fresh or Par-Baked Doughs
- 19" Bake Area on Each Nickel Plated Deck

**ELECTRICAL**

- 208-240V - 50/60 Hertz - 1 Ph - 26 Amps - 5.4 kW - NEMA 6-30P

**FINISH**

Stainless Steel

**STANDARD PRODUCT WARRANTY**

One Year Labor and Two Year Parts

**CAPACITY**

(3) Half Size Sheet Pans (13" x 18" - 330mm x 457mm)  
Shelf Spacing: 4" (102 mm)

(3) 18" Pizzas (Directly on Nickel Deck)  
Shelf Spacing: 4" (102 mm)

**OPTIONS**

- Stainless Steel Stand on Swivel Casters (2-Locking & Non-Locking) (RPOT)

**DIMENSIONS & SHIPPING WEIGHT**

27 1/2"W X 34"D X 28 1/2"H  
(699 mm X 864 mm X 724 mm)  
400 lb (182 kg)

**INTERIOR DIMENSIONS**

22"W X 21"D X 14"H  
(559 mm X 533 mm X 356 mm)

**DOOR OPENING**

22"W X 14"D  
(559 mm X 356 mm)

**SHORT SPECIFICATION**

Convection Oven, Electric, Designed for Pizzas & More, Rotating Nickel Plated Decks (3), Capacity up to (3) 18" Pizzas, Programmable Touchscreen Control, Stainless Steel Construction, Ventless (No Hood Required) Stackable, Single Handle Drop Down Style Door, Fully Illuminated, One Year Labor & Two Year Parts Warranty

## DRAWINGS

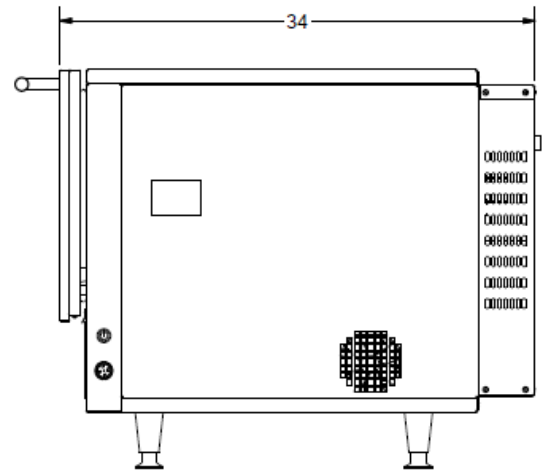
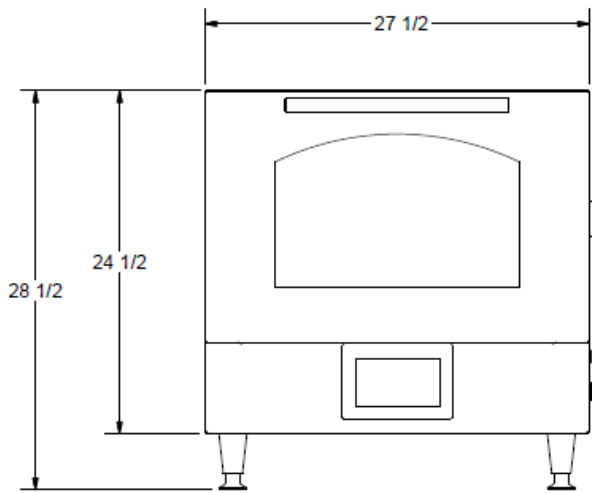

## PRODUCTION CAPACITY

Product	State	Bake Time	Bake Temp (°F)	Bake Temp (°C)	Quantity Produced
6" Traditional Pizza	Fresh	5	500	260	90
9" Traditional Pizza	Fresh	5	500	260	60
12" Traditional Pizza	Par-Baked	4	500	260	36
14" Deep Dish Pizza	Fresh	7	480	249	24
Italian Sub, 6"	Pre-Baked Bread	3	480	249	150
Mexican Platter	Heated	2	425	218	81
Nachos, 3 oz of Chips	Fresh	2	500	260	81
Biscuits	Refrigerated (6/Pan)	6 1/2	400	204	168
Chicken Breast, 6 oz	Boneless, Refrigerated	6 1/2	450	232	144
Chicken Quarters, Pre-Cooked	Refrigerated	9	480	249	54
Chicken Wings	Fresh	15	400	204	216



5600 13th Street  
Menominee, MI 49858  
sales@nu-vu.com  
(800) 338-9886 Toll Free  
(906) 843-4401 Phone  
(906) 863-5889 Fax  
www.doyon.qc.ca

**SPECIFICATIONS SUBJECT TO CHANGE WITHOUT NOTICE  
KCL & REVIT DRAWINGS UPON REQUEST**

REF: FIN SPEC1

Rev 8—3/1/2019