

robot *coupe*®



POWER MIXERS



RESTAURANTS - CATERERS - DELICATESSENS

COMPACT

"All Robot Coupe Power Mixers
have One Year "No Hassle"
Replacement Warranty"

MINI

Mini MP

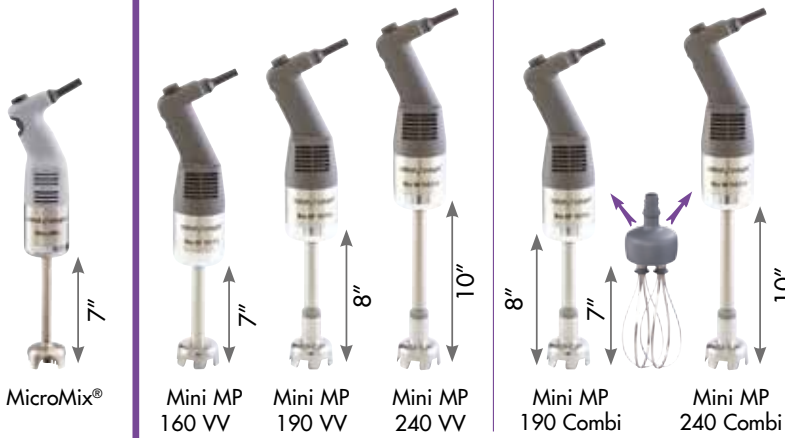

MicroMix®

Mini MP
160 VV

Mini MP
190 VV

Mini MP
240 VV

Mini MP
190 Combi

Mini MP
240 Combi

Ideal for smaller quantities

CMP



CMP 250 VV

CMP 400 VV

CMP 250 Combi

15 L

73 L

15 L

Restaurants

▶ Special for emulsions

▶ For handling small quantities

▶ Special for restaurants
Up to 73 Liters

▶ Intended for institutional and commercial caterers. Intensive use.

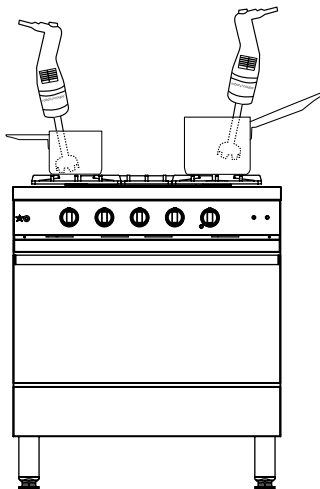

MicroMix®

Mini MP

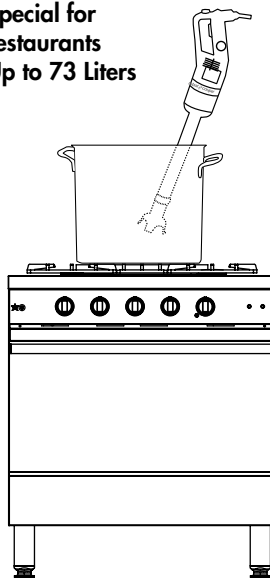

CMP

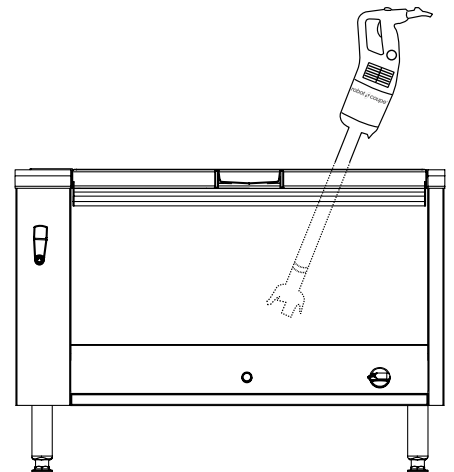

▶ **COMPACT Range**



▶ **Mixer**



▶ **Beat**

SPECIALLY DESIGNED FOR THE CATERING SECTOR

COMBI



CMP 250 V.V.



CMP 400 V.V.



CMP 250 Combi

5,000 to 10,000 rpm

Mixer: 2,300 to 10,000 rpm
Whisk: 500 to 1,800 rpm

▶ COMPACT Range

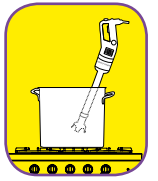

SPECIAL CATERING MODELS UP TO 100 Liters

ERGONOMIC



Compact, lightweight appliance that is easy to handle

COMFORT



Variable speed function providing the greater flexibility required for sophisticated preparations.

POWER



More powerful motor: + 15% for even more efficient machine.

SANITATION



Removable stainless steel blade and bell for easy cleaning and maintenance.

PERFORMANCE



The CMP Combi models (mixer+whisk) also boast a new 100% stainless-steel bell



Optimum blending quality giving the finished product a fine texture within a minimum of time.



CMP Combi

STURDINESS

- **Whisk housing with all-metal interior for greater resilience.**
- **Overmoulded whisks ensuring perfect sanitation.**

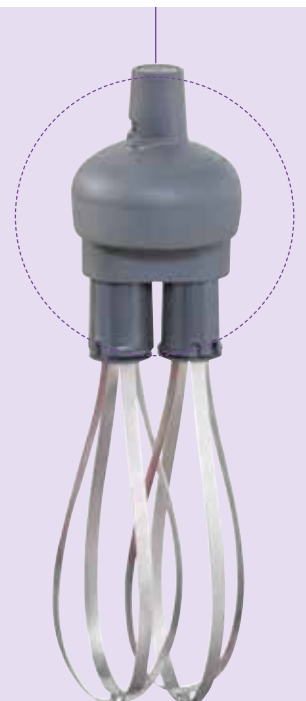

COMPACT RANGE - VARIABLE SPEED MIXERS

CMP 250 V.V. - CMP 400 V.V.

- Automatic speed regulating system
- Delivered with 1 stainless steel wall support and blade disassembly tool.
- ETL electrical and sanitation listed/cETL (Canada)**
- Nema #: 5-15P**

SELF REGULATING SPEED

CMP 250 V.V. VARIABLE SPEED

Power	310 Watts
Voltage	Single phase
Variable speed	from 5000 to 10000 rpm
Blade, foot and shaft	10" length - all stainless steel
Removable bell	a Robot Coupe exclusive
Dimensions L x W	26" x 3 9/16" - Cube: .68
Approx. shipping weight	10 lbs
Approx. carton size (WxDxH)	27.25" x 9" x 4.5" - Cube: 0.64

CMP 400 V.V. VARIABLE SPEED

Power	420 Watts
Voltage	Single phase
Variable speed	from 5000 to 10000 rpm
Blade, foot and shaft	16" length - all stainless steel
Removable bell	a Robot Coupe exclusive
Dimensions L x W	30" x 3 9/16"
Approx. shipping weight	11 lbs
Approx. carton size (WxDxH)	36.75" x 11" x 6" - Cube: 1.40



COMPACT RANGE - COMBI MIXER/WHISK

CMP 250 Combi

Power	310 Watts
Voltage	Single phase
Variable speed	2300 to 10000 rpm (Mixer attachment) from 500 to 1800 rpm (whisk attachment)
Whisk	8" length
Blade, foot and shaft	10" length - all stainless steel
Removable shaft and bell	a Robot Coupe exclusive
Dimensions L x W	29 15/16" - 3 9/16"
Approx. shipping weight	13 lbs
Approx. carton size (WxDxH)	22" x 13.5" x 5" - Cube: 0.86

