

iMIX-5 Black

32.8" x 24.0" x 19.3"
(83.3cm x 61.0cm x 49.0cm)



- 7gal (26.5L) hot water tank to meet peak serving times
- Alphanumeric display communicates advertising messages, machine status and technical support contact information
- Auger motors with RPM feedback monitoring assure consistent flavors and profits by controlling powder dosing
- Capacity: Five 8lb (3.6kg) hoppers
- Cup clearance at 7.25" (18.4cm) to accommodate popular cup sizes [adjustable to 8.12" (20.6cm)]
- Front of machine access to tank drain, dump valves, auger and whipper motors and control board for easy service set up and calibration
- High speed heavy-duty whipper for complete product mixing
- Low product detection system alerts audibly and with message on display when hoppers are low
- High efficiency LED lighted front graphics for merchandising
- Night mode to prevent pilferage
- Spring-loaded, all metal auger drive system for easy hopper installation

Agency:



Specifications

Product #: 37000.0000

Dispense: Push Button

Water Access: Plumbed

Finish: Black

Hoppers: Five

Door: Side Hinge

Additional Features

BUNNLINK Compatible

Hot Water Button

Electrical & Capacity

Volts	Amps	Watts	Cord Attached	Plug Type	8oz cups/hr 236ml cups/hr	Input H ₂ O Temp.	Phase	# Wires plus Ground	Hertz
120	15	1800	Yes	NEMA 5-15P	72	60°F (15.5°C)	1	2	60

Plumbing Requirements

PSI	kPa	Fitting Supplied	Water Flow Required (GPM)
20-100	138-689	1/4" Male Flare Fitting	-

CAD Drawings

2D	Revit	KLC
●	●	●



BUNN® reserves the right to change specifications and product design without notice. Such revisions do not entitle the buyer to corresponding changes, improvements, additions or replacements for previously purchased equipment. For most current specifications and other info visit bunn.com.

Created on:
01/03/2019

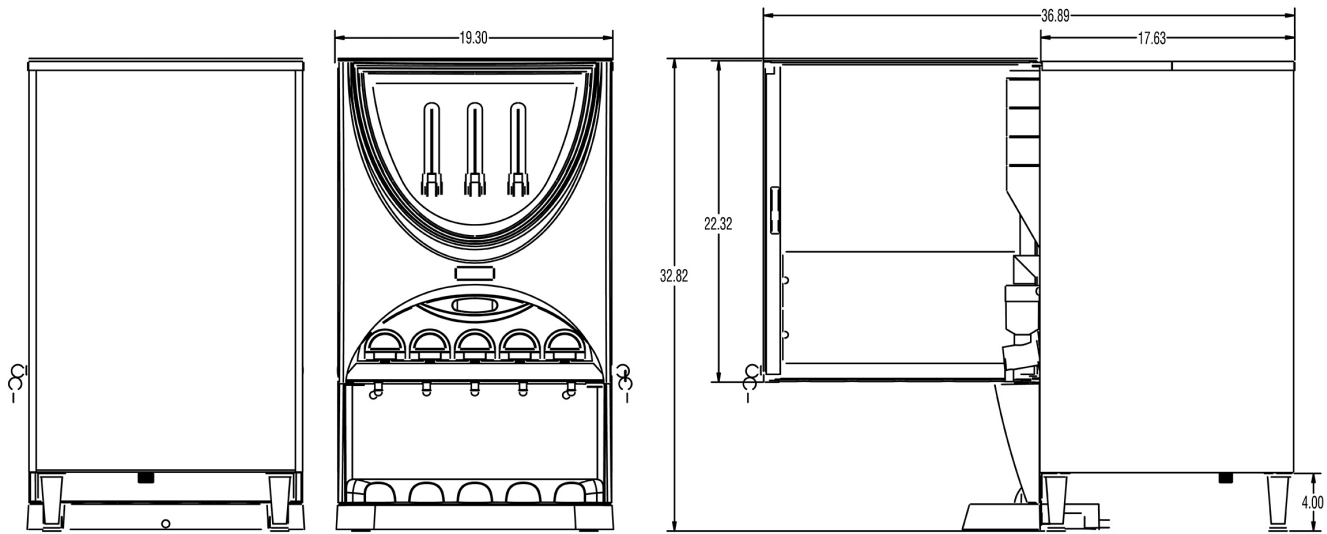

side hinged model
side views

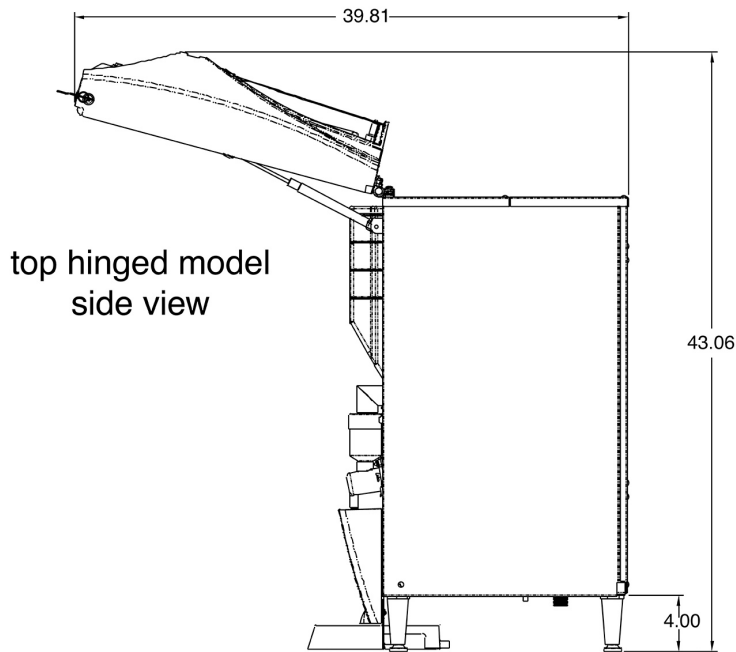

top hinged model
side view

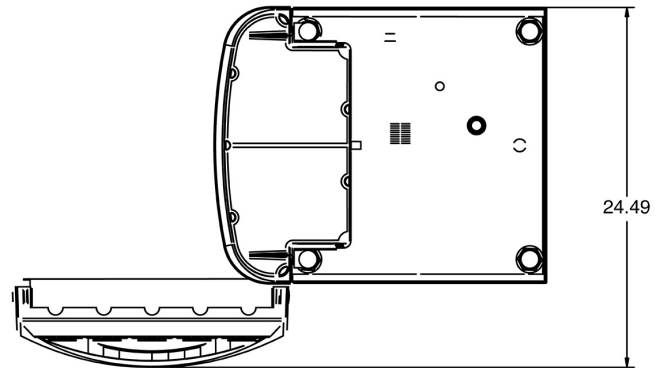

	Unit			Shipping				
	Width	Height	Depth	Width	Height	Depth	Weight	Volume
English	19.3 in.	32.8 in.	24.0 in.	-	-	-	133.450 lbs	-
Metric	49.0 cm	83.3 cm	61.0 cm	-	-	-	60.533 kgs	-



BUNN® reserves the right to change specifications and product design without notice. Such revisions do not entitle the buyer to corresponding changes, improvements, additions or replacements for previously purchased equipment. For most current specifications and other info visit bunn.com.

Created on:
01/03/2019

Related Products & Accessories:iMIX-5 Black(37000.0000)

DISPLAY, GRAPHICS
(iMIX-4/5)

Product #: 36768.0000

DISPLAY,GRAPHICS
ICED CAP

Product #: 36768.0005



WATER FILTER,
EQHP-10L

Product #: 39000.0001



WATER FILTER,
EQHP-10

Product #: 39000.0004



BUNN® reserves the right to change specifications and product design without notice. Such revisions do not entitle the buyer to corresponding changes, improvements, additions or replacements for previously purchased equipment. For most current specifications and other info visit bunn.com.

Created on:
01/03/2019

Serving & Holding Options: iMIX-5 Black(37000.0000)

Serving and Holding selections are currently unavailable. Please contact your sales representative to find out more information.



BUNN® reserves the right to change specifications and product design without notice. Such revisions do not entitle the buyer to corresponding changes, improvements, additions or replacements for previously purchased equipment. For most current specifications and other info visit bunn.com.

Created on:
01/03/2019

iMIX-5 Black, Top Hinge Door

32.8" x 24.0" x 19.3"
(83.3cm x 61.0cm x 49.0cm)



- 7gal (26.5L) hot water tank to meet peak serving times
- Alphanumeric display communicates advertising messages, machine status and technical support contact information
- Auger motors with RPM feedback monitoring assure consistent flavors and profits by controlling powder dosing
- Capacity: Five 8lb (3.6kg) hoppers
- Cup clearance at 7.25" (18.4cm) to accommodate popular cup sizes [adjustable to 8.12" (20.6cm)]
- Front of machine access to tank drain, dump valves, auger and whipper motors and control board for easy service set up and calibration
- High speed heavy-duty whipper for complete product mixing
- Low product detection system alerts audibly and with message on display when hoppers are low
- High efficiency LED lighted front graphics for merchandising
- Night mode to prevent pilferage
- Spring-loaded, all metal auger drive system for easy hopper installation

Agency:



Specifications

Product #: 37000.0020

Dispense: Push Button

Water Access: Plumbed

Finish: Stainless

Hoppers: Five

Door: Top Hinge

Additional Features

BUNNLINK Compatible

Electrical & Capacity

Volts	Amps	Watts	Cord Attached	Plug Type	8oz cups/hr 236ml cups/hr	Input H ₂ O Temp.	Phase	# Wires plus Ground	Hertz
120	15	1800	Yes	NEMA 5-15P	72	60°F (15.5°C)	1	2	60

Plumbing Requirements

PSI	kPa	Fitting Supplied	Water Flow Required (GPM)
20-100	138-689	1/4" Male Flare Fitting	-

CAD Drawings

2D	Revit	KLC
●	●	●



BUNN® reserves the right to change specifications and product design without notice. Such revisions do not entitle the buyer to corresponding changes, improvements, additions or replacements for previously purchased equipment. For most current specifications and other info visit bunn.com.

Created on:
01/03/2019

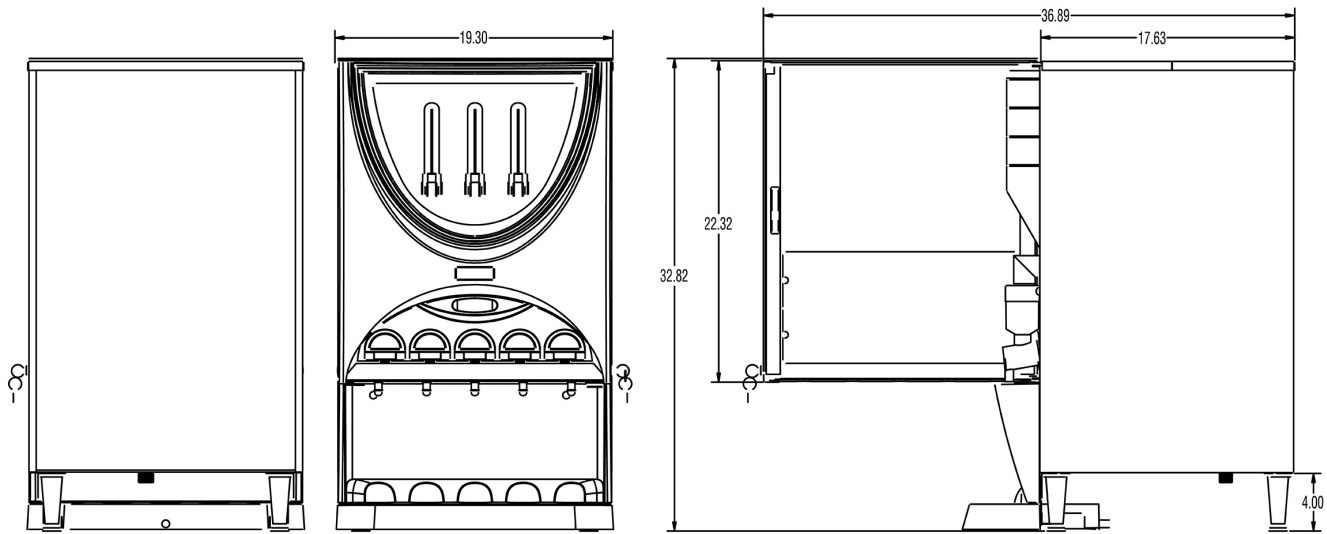

side hinged model
side views

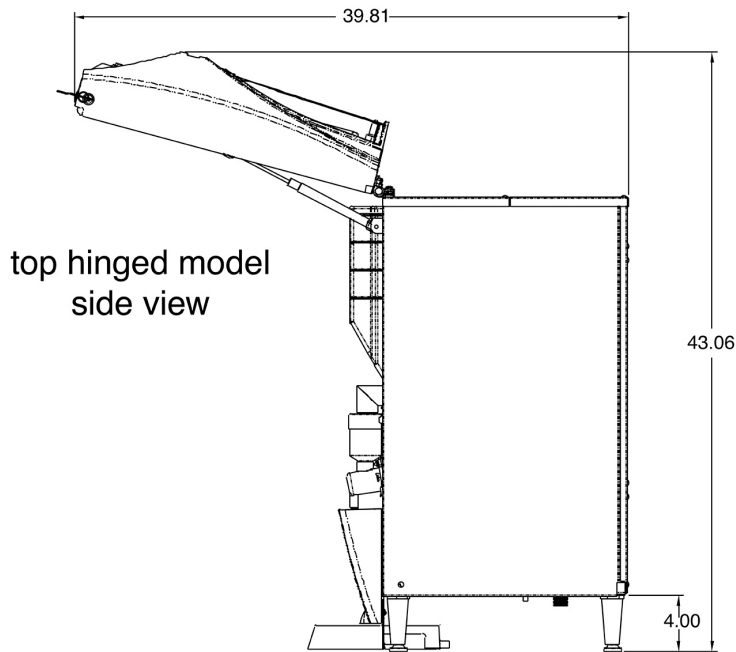

top hinged model
side view

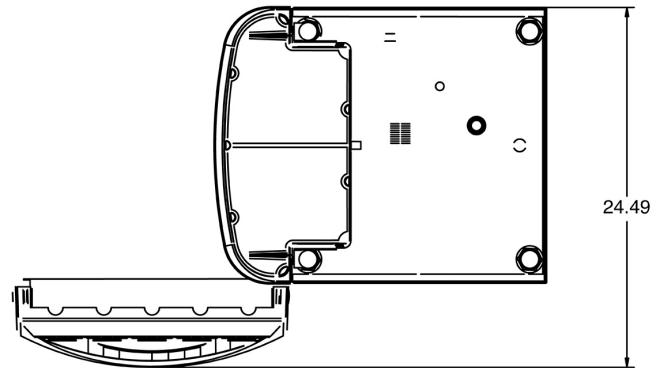

	Unit			Shipping				
	Width	Height	Depth	Width	Height	Depth	Weight	Volume
English	19.3 in.	32.8 in.	24.0 in.	-	-	-	135.050 lbs	-
Metric	49.0 cm	83.3 cm	61.0 cm	-	-	-	61.259 kgs	-



BUNN® reserves the right to change specifications and product design without notice. Such revisions do not entitle the buyer to corresponding changes, improvements, additions or replacements for previously purchased equipment. For most current specifications and other info visit bunn.com.

Created on:
01/03/2019

Related Products & Accessories:iMIX-5 Black, Top Hinge Door(37000.0020)

DISPLAY, GRAPHICS
(iMIX-4/5)

Product #: 36768.0000

DISPLAY,GRAPHICS
ICED CAP

Product #: 36768.0005



WATER FILTER,
EQHP-10L

Product #: 39000.0001



WATER FILTER,
EQHP-10

Product #: 39000.0004



BUNN® reserves the right to change specifications and product design without notice. Such revisions do not entitle the buyer to corresponding changes, improvements, additions or replacements for previously purchased equipment. For most current specifications and other info visit bunn.com.

Created on:
01/03/2019

Serving & Holding Options: iMIX-5 Black, Top Hinge Door(37000.0020)

Serving and Holding selections are currently unavailable. Please contact your sales representative to find out more information.



BUNN® reserves the right to change specifications and product design without notice. Such revisions do not entitle the buyer to corresponding changes, improvements, additions or replacements for previously purchased equipment. For most current specifications and other info visit bunn.com.

Created on:
01/03/2019

iMIX-5S+

32.8" x 24.0" x 19.3"
(83.3cm x 61.0cm x 49.0cm)



- 7gal (26.5L) hot water tank to meet peak serving times
- Alphanumeric display allows adjustments and service operational testing from front of machine. Also communicates advertising messages, machine status and technical support contact information
- Can be set as push and hold or single size portion control
- Capacity: Five 8lb (3.6kg) hoppers
- Cup clearance at 7.25" (18.4cm) to accommodate popular cup sizes [adjustable to 8.12" (20.6cm)]
- Easily removable side panels for complete access to service components
- Front of machine access to tank drain, dump valves, auger and whipper motors and control board for easy service set up and calibration
- High speed heavy-duty whipper for complete product mixing
- High efficiency LED lighted front graphics for merchandising
- Spring-loaded, all metal auger drive system for easy hopper installation
- Variable speed motors allow control of product consistency in mixing chamber (.75 to 6.6 grams of powder per second)

Agency:



Specifications

Product #: 38100.0003

Water Access: Plumbed

Finish: Black

Hoppers: Five

Door: Lit

Door: Side Hinge

Dispense: Portion Control

Dispense: Push Button

Additional Features

Electrical & Capacity

Volts	Amps	Watts	Cord Attached	Plug Type	8oz cups/hr 236ml cups/hr	Input H ² O Temp.	Phase	# Wires plus Ground	Hertz
120	15	1800	Yes	NEMA 5-15P	72	60°F (15.5°C)	1	2	50/60

Plumbing Requirements

PSI	kPa	Fitting Supplied	Water Flow Required (GPM)
20-100	138-689	1/4" Male Flare Fitting	-

CAD Drawings

2D	Revit	KLC
●	●	●



BUNN® reserves the right to change specifications and product design without notice. Such revisions do not entitle the buyer to corresponding changes, improvements, additions or replacements for previously purchased equipment. For most current specifications and other info visit bunn.com.

Created on:
01/03/2019

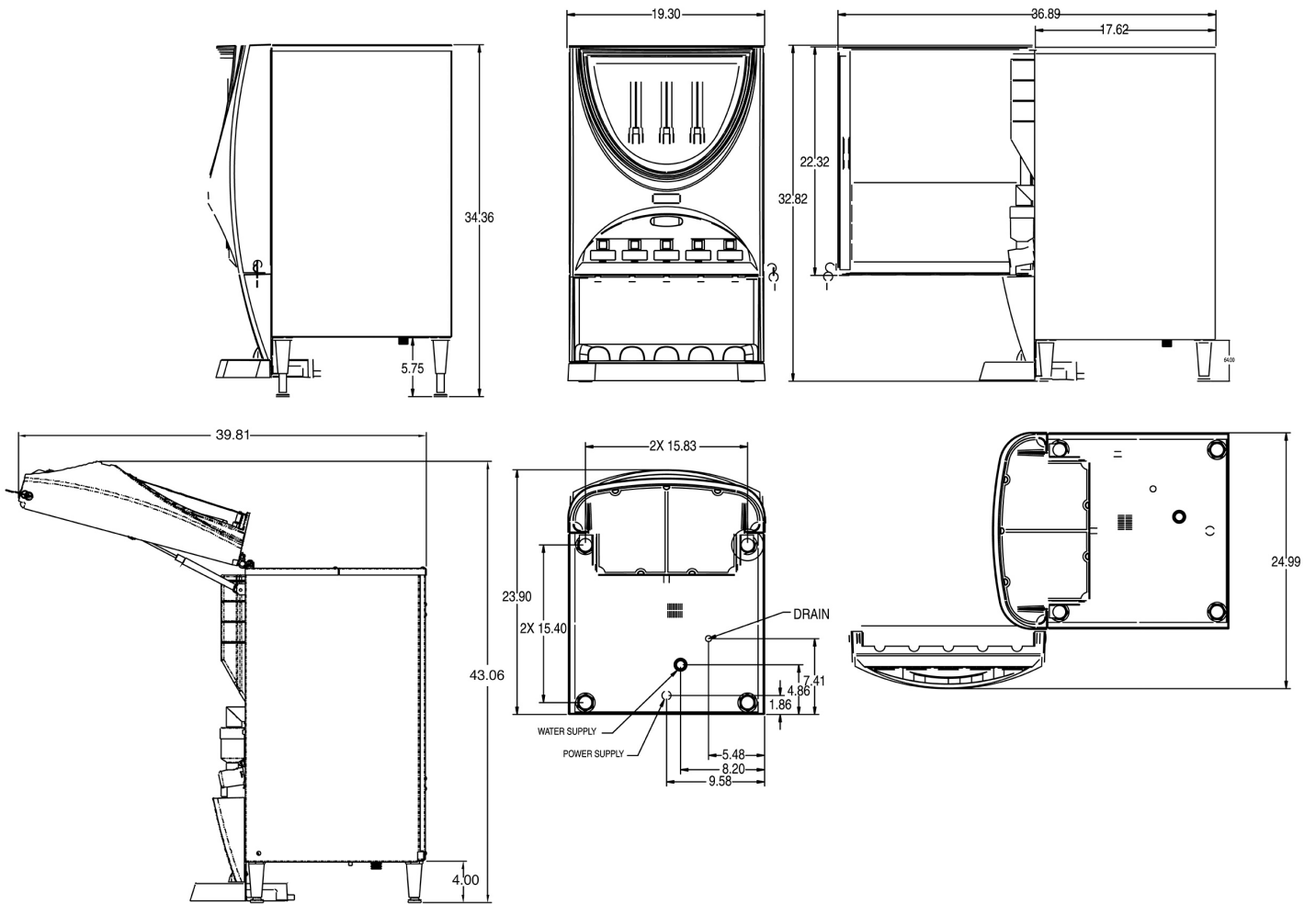

Unit			Shipping					
	Width	Height	Depth	Width	Height	Depth	Weight	Volume
English	19.3 in.	32.8 in.	24.0 in.	-	-	-	130.600 lbs	-
Metric	49.0 cm	83.3 cm	61.0 cm	-	-	-	59.240 kgs	-



BUNN® reserves the right to change specifications and product design without notice. Such revisions do not entitle the buyer to corresponding changes, improvements, additions or replacements for previously purchased equipment. For most current specifications and other info visit bunn.com.

Created on:
01/03/2019

Related Products & Accessories:iMIX-5S+(38100.0003)

DISPLAY, GRAPHICS
(iMIX-4/5)

Product #: 36768.0000

DISPLAY,GRAPHICS
ICED CAP

Product #: 36768.0005



WATER FILTER,
EQHP-10L

Product #: 39000.0001



WATER FILTER,
EQHP-10

Product #: 39000.0004



BUNN® reserves the right to change specifications and product design without notice. Such revisions do not entitle the buyer to corresponding changes, improvements, additions or replacements for previously purchased equipment. For most current specifications and other info visit bunn.com.

Created on:
01/03/2019

Serving & Holding Options: iMIX-5S+(38100.0003)

Serving and Holding selections are currently unavailable. Please contact your sales representative to find out more information.



BUNN® reserves the right to change specifications and product design without notice. Such revisions do not entitle the buyer to corresponding changes, improvements, additions or replacements for previously purchased equipment. For most current specifications and other info visit bunn.com.

Created on:
01/03/2019