

# iMIX-3 Black

32.8" x 24.1" x 12.6"  
(83.3cm x 61.2cm x 32.0cm)



- 4.4gal (16.7L) hot water tank to meet peak serving times
- Alphanumeric display communicates advertising messages, machine status and technical support contact information
- Auger motors with RPM feedback monitoring assure consistent flavors and profits by controlling powder dosing
- Capacity: Three 8lb (3.6kg) hoppers
- Cup clearance at 7.25" (18.4cm) to accommodate popular cup sizes [adjustable to 8.12" (20.6cm)]
- Front of machine access to tank drain, dump valves, auger and whipper motors and control board for easy service set up and calibration
- High speed heavy-duty whipper for complete product mixing
- Low product detection system alerts audibly and with message on display when hoppers are low
- High efficiency LED lighted front graphics for merchandising
- Night mode to prevent pilferage
- Spring-loaded, all metal auger drive system for easy hopper installation

Agency:



## Specifications

**Product #:** 36900.0000

**Dispense:** Push Button

**Water Access:** Plumbed

**Finish:** Black

**Hoppers:** Three

**Door:** Side Hinge

## Additional Features

BUNNLINK Compatible

## Electrical & Capacity

Volts	Amps	Watts	Cord Attached	Plug Type	8oz cups/hr 236ml cups/hr	Input H <sub>2</sub> O Temp.	Phase	# Wires plus Ground	Hertz
120	15	1800	Yes	NEMA 5-15P	72	60°F (15.5°C)	1	2	50/60

## Plumbing Requirements

PSI	kPa	Fitting Supplied	Water Flow Required (GPM)
20-100	138-689	1/4" Male Flare Fitting	-

## CAD Drawings

2D	Revit	KLC
●	●	●



BUNN® reserves the right to change specifications and product design without notice. Such revisions do not entitle the buyer to corresponding changes, improvements, additions or replacements for previously purchased equipment. For most current specifications and other info visit [bunn.com](http://bunn.com).

Created on:  
01/03/2019

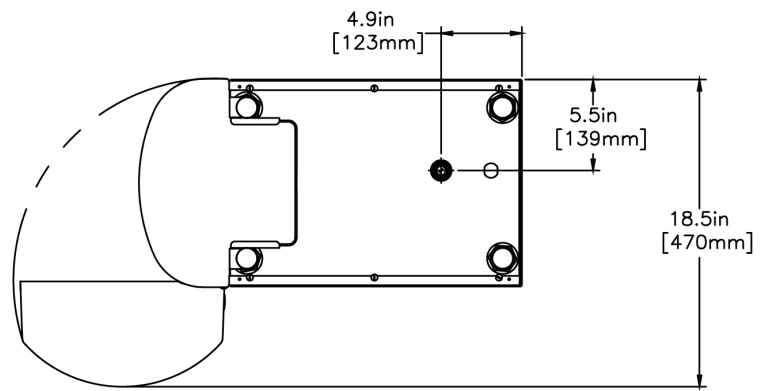
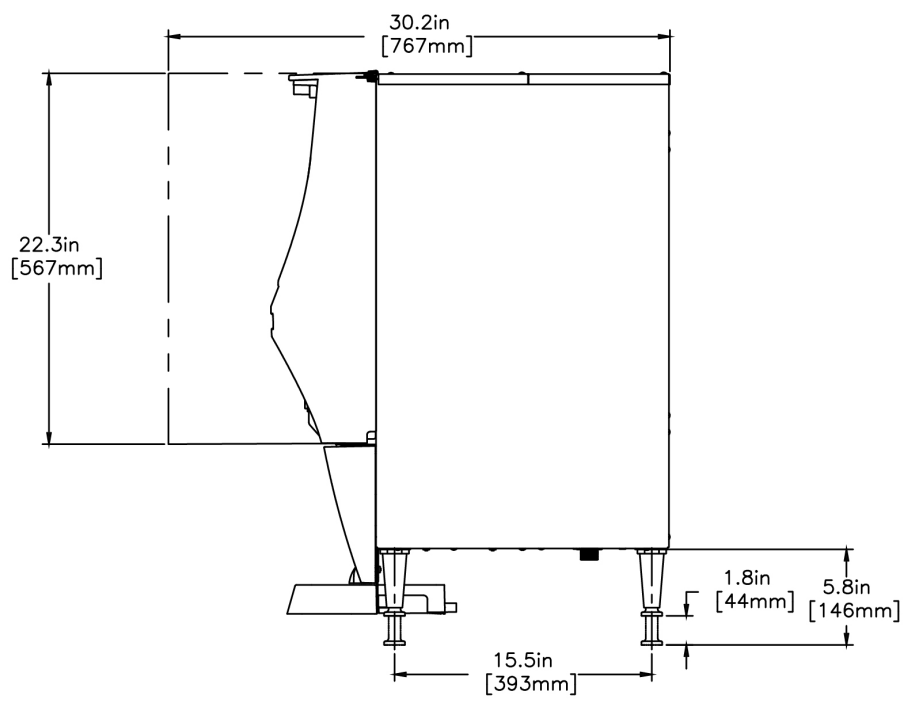
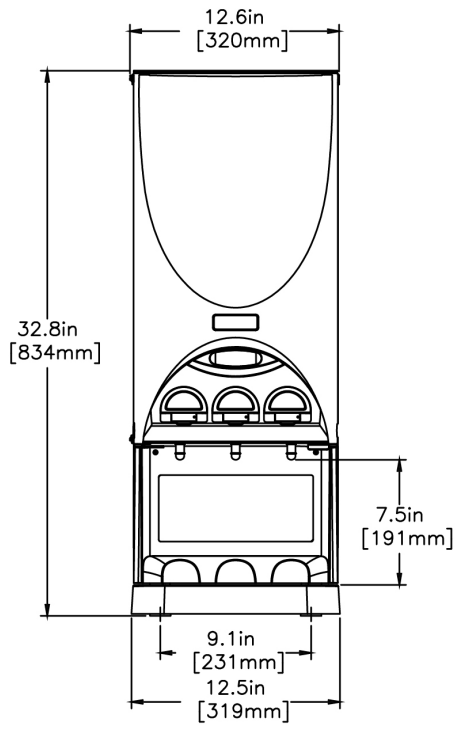

	Unit			Shipping				
	Width	Height	Depth	Width	Height	Depth	Weight	Volume
English	12.6 in.	32.8 in.	24.1 in.	-	-	-	101.810 lbs	-
Metric	32.0 cm	83.3 cm	61.2 cm	-	-	-	46.181 kgs	-



BUNN® reserves the right to change specifications and product design without notice. Such revisions do not entitle the buyer to corresponding changes, improvements, additions or replacements for previously purchased equipment. For most current specifications and other info visit [bunn.com](http://bunn.com).

Created on:  
01/03/2019

## Related Products & Accessories:iMIX-3 Black(36900.0000)



DISPLAY GRAPHICS  
IMIX-3

Product #: 37457.0000



DISPLAY, GRAPHICS  
CHAI TEA

Product #: 37457.0001



DISPLAY, GRAPHICS  
HOT CHOC

Product #: 37457.0002



DISPLAY, GRAPHICS  
STEAMERS

Product #: 37457.0003



DISPLAY, GRAPHICS  
ICED CAP

Product #: 37457.0006



WATER FILTER,  
EQHP-10L

Product #: 39000.0001



WATER FILTER,  
EQHP-10

Product #: 39000.0004



BUNN® reserves the right to change specifications and product design without notice. Such revisions do not entitle the buyer to corresponding changes, improvements, additions or replacements for previously purchased equipment. For most current specifications and other info visit [bunn.com](http://bunn.com).

Created on:  
01/03/2019

## Serving & Holding Options: iMIX-3 Black(36900.0000)

\*Serving and Holding selections are currently unavailable. Please contact your sales representative to find out more information.\*



BUNN® reserves the right to change specifications and product design without notice. Such revisions do not entitle the buyer to corresponding changes, improvements, additions or replacements for previously purchased equipment. For most current specifications and other info visit [bunn.com](http://bunn.com).

Created on:  
01/03/2019

# iMIX-3S+

32.8" x 24.1" x 12.6"  
(83.3cm x 61.2cm x 32.0cm)



- 4.3gal (16.3L) hot water tank to meet peak serving times
- High efficiency LED lighted front graphics for merchandising
- Alphanumeric display allows adjustments and service operational testing from front of machine. Also communicates advertising messages, machine status and technical support contact information
- Can be set as push and hold or single size portion control
- Capacity: Three 8lb (3.6kg) hoppers
- Cup clearance at 7.25" (18.4cm) to accommodate popular cup sizes [adjustable to 8.12" (20.6cm)]
- Easily removable side panels for complete access to service components
- Front of machine access to tank drain, dump valves, auger and whipper motors and control board for easy service set up and calibration
- High speed heavy-duty whipper for complete product mixing
- Spring-loaded, all metal auger drive system for easy hopper installation
- Variable speed motors allow control of product consistency in mixing chamber (.75 to 6.6 grams of powder per second)

Agency:



## Specifications

**Product #:** 38600.0001

**Water Access:** Plumbed

**Finish:** Black

**Hoppers:** Three

**Door:** Side Hinge

**Dispense:** Portion Control

**Dispense:** Push Button

## Additional Features

## Electrical & Capacity

Volts	Amps	Watts	Cord Attached	Plug Type	8oz cups/hr 236ml cups/hr	Input H <sup>2</sup> O Temp.	Phase	# Wires plus Ground	Hertz
120	15	1800	Yes	NEMA 5-15P	72	60°F (15.5°C)	1	2	50/60

## Plumbing Requirements

PSI	kPa	Fitting Supplied	Water Flow Required (GPM)
20-100	138-689	1/4" Male Flare Fitting	-

## CAD Drawings

2D	Revit	KLC
●	●	●



BUNN® reserves the right to change specifications and product design without notice. Such revisions do not entitle the buyer to corresponding changes, improvements, additions or replacements for previously purchased equipment. For most current specifications and other info visit [bunn.com](http://bunn.com).

Created on:  
01/03/2019

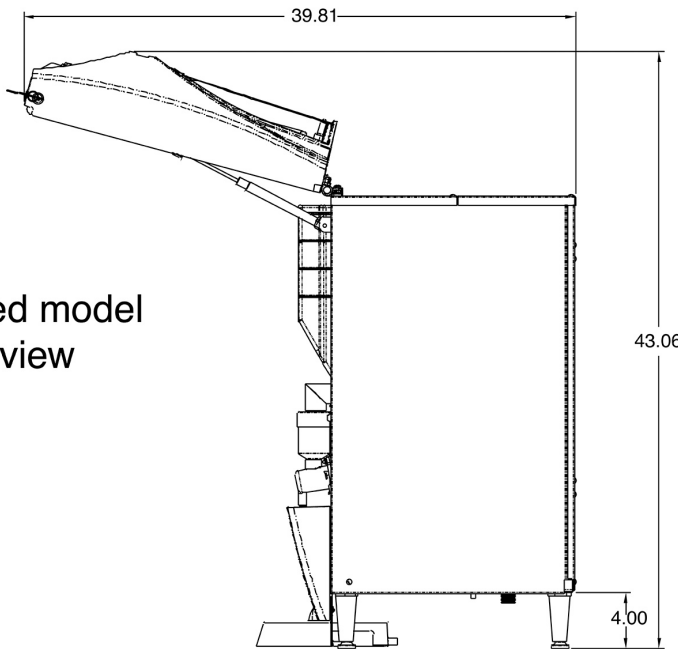
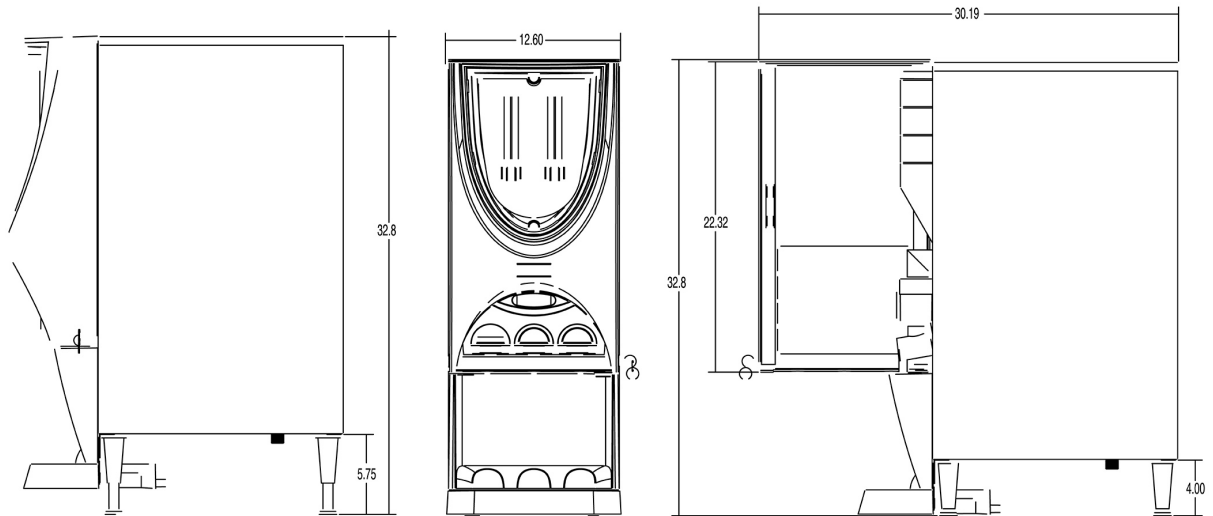

top hinged model  
side view

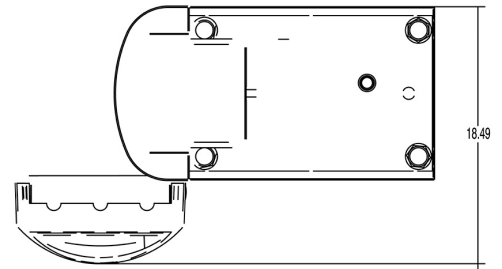

side hinged model  
side views

	Unit			Shipping				
	Width	Height	Depth	Width	Height	Depth	Weight	Volume
English	12.6 in.	32.8 in.	24.1 in.	-	-	-	100.500 lbs	-
Metric	32.0 cm	83.3 cm	61.2 cm	-	-	-	45.587 kgs	-



BUNN® reserves the right to change specifications and product design without notice. Such revisions do not entitle the buyer to corresponding changes, improvements, additions or replacements for previously purchased equipment. For most current specifications and other info visit [bunn.com](http://bunn.com).

Created on:  
01/03/2019

## Related Products & Accessories:iMIX-3S+(38600.0001)



DISPLAY GRAPHICS  
IMIX-3

Product #: 37457.0000



DISPLAY, GRAPHICS  
CHAI TEA

Product #: 37457.0001



DISPLAY, GRAPHICS  
HOT CHOC

Product #: 37457.0002



DISPLAY, GRAPHICS  
STEAMERS

Product #: 37457.0003



DISPLAY, GRAPHICS  
ICED CAP

Product #: 37457.0006



WATER FILTER,  
EQHP-10L

Product #: 39000.0001



WATER FILTER,  
EQHP-10

Product #: 39000.0004



BUNN® reserves the right to change specifications and product design without notice. Such revisions do not entitle the buyer to corresponding changes, improvements, additions or replacements for previously purchased equipment. For most current specifications and other info visit [bunn.com](http://bunn.com).

Created on:  
01/03/2019

# Serving & Holding Options: iMIX-3S+(38600.0001)

\*Serving and Holding selections are currently unavailable. Please contact your sales representative to find out more information.\*



BUNN® reserves the right to change specifications and product design without notice. Such revisions do not entitle the buyer to corresponding changes, improvements, additions or replacements for previously purchased equipment. For most current specifications and other info visit [bunn.com](http://bunn.com).

Created on:  
01/03/2019