



efi sales Ltd.
Equipment for the Foodservice Industry

Project Name: _____
Product Number: _____
Quantity: _____

VERSA-CHILL WORKTOP FREEZERS WITH DOORS

GENERAL

Using steel construction, these undercounter freezers are available in 3 sizes to meet your needs.

Cabinet Construction

The exterior sides and front are covered in 24 Gauge, type 430 Stainless Steel.

The interior walls and doors are covered in 22 Gauge, type 430 Stainless Steel and the floors are covered in 24 Gauge, type 304 Stainless Steel.

The inside corners are rounded for easy cleaning.

The units come equipped with adjustable PVC coated shelves.

These units come equipped with a backsplash to prevent items falling behind.

The entire unit is built using a high density Polyurethane insulation that is applied in place.

Doors

Recessed handles for smoother front and reduced space requirements.

The gasket is magnetized to provide easy removal for cleaning.

Self-closing doors equipped with "stay open" feature when opened past 90 degrees.

Refrigeration

Oversized factory balanced system designed to hold -8 to -1 degrees Fahrenheit.

The refrigeration system uses R134A and R404A that is CFC and HCFC free.

Condensor unit is easily accessible for routine cleaning and maintenance.

Electrical

Units come factory wired and ready to connect with 115/60/1 phase, 15 amp dedicated plug and cord.



FWDR1-27VC



FWDR2-48VC



FWDR2-60VC

FRONT ELEVATIONS

MODEL	FWDR1-27VC	FWDR2-48VC	FWDR2-60VC
EXTERNAL DIMENSIONS			
Overall Width inches / mm	27.5 / 698	48.2 / 1224	60.2 / 1529
Overall Depth inches / mm	30 / 762	30 / 762	30 / 762
Overall Height inches / mm	40.1 / 1019	40.1 / 1019	40.1 / 1019
Number of Doors	1	2	2
INTERNAL DIMENSIONS			
Capacity Cubic ft. / litres	6.5 / 184.1	12 / 339.8	17.9 / 506.9
Internal Width inches / mm	23.9 / 608	44.7 / 1135	60.2 / 1529
Internal Depth inches / mm	23.6 / 600	23.9 / 608	23.9 / 608
Internal Height inches / mm	26.7 / 678	26.7 / 678	26.7 / 678
Number of shelves	1	2	2
ELECTRICAL			
Full Load Amperes 115/60/1	4.4	6.5	6.5
Cord Length Feet / Meters	8.5 / 2.6	8.5 / 2.6	8.5 / 2.6
Plug type	NEMA 5-15P	NEMA 5-15P	NEMA 5-15P
REFRIGERATION DATA			
Refrigerant	R134A	R404A	R404A
Horsepower	1/4	1/2	1/2
WEIGHT			
Gross Weight lbs / kg	209 / 94.8	267 / 121.1	320 / 145.1

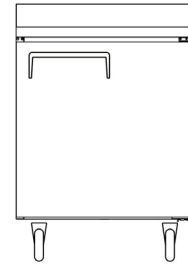

FWDR1-27VC

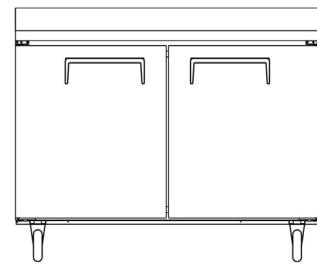

FWDR2-48VC

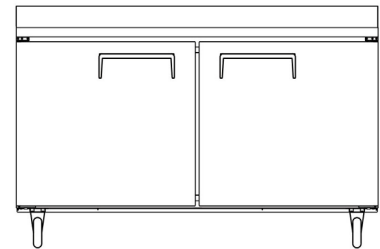

FWDR2-60VC

SIDE ELEVATION

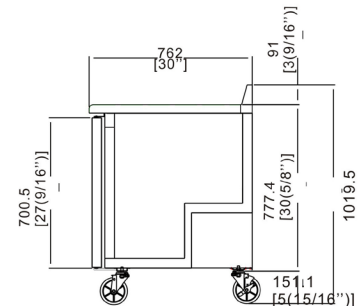

5-15P

WARRANTY INFORMATION

One year parts and labour.
Five years on compressor.



EFI Sales Ltd.
Corporate Office
26895 Gloucester Way
Langley, BC V4W 3Y3

(604) 607-8850
(888) 565-9920 Toll Free
(604) 607-8820 Fax
info@efifoodequip.com

Distribution Facilities:
Toronto, ON
Langley, BC