

Sunfire SCO Series Gas Convection Oven

Project _____
 Item _____
 Quantity _____
 CSI Section 11400
 Approved _____
 Date _____

Models

- SCO-GS-10S
- SCO-GS-10ESS (Energy Star)
- SCO-GS-20S
- SCO-GS-20ESS (Energy Star)



SCO-GS-10S

Standard Features

- SUNFIRE Series Solid State control with digital timer
- Direct spark ignition with 100% safety shutoff
- Single speed fan control with 0.6 HP fan motor
- Total of 53,000 BTU (15.53 kW) loading per oven cavity
- Natural gas only.
- Stainless steel front, sides, top, and legs
- 60/40 dependent solid door design
- Porcelain enameled oven interior with coved corners
- Five (5) chrome plated ovens racks on 13-position rack guides
- Double deck models available.

Warranty

- One year limited parts and labor warranty (USA and Canada only)
- Three year limited door warranty (USA and Canada only)

Options & Accessories

- Two speed fan
- Two speed fan windows in left door and interior oven lights.
- Extra oven racks
- Swivel casters, (4) w/ front brakes
- Low profile casters, (4) w/ front brakes (double ovens only)
- Open base with rack guides and shelf (stainless steel)
- Direct connect vent
- Gas flex hose w/quick disconnect & restraining device
- Back enclosure (stainless steel)
- Maximum security options available.
- Removable stainless steel drip pan.

Specifications

- SUNFIRE Full-Size Standard Depth gas convection oven.
- 53,000 BTU/hr (15.53)/cavity, 0.6 HP single-speed fan motor.
- Direct spark ignition. Natural gas. Solid State Control with digital timer. 115 volt single phase, 60 Hz.
- Porcelain enameled oven interior with coved corners, five (5) oven racks and 13 position rack guides.
- All model interiors are 29" (736mm) wide by 24" (610mm) deep. Stainless steel front, sides, top and legs. 60/40 dependent solid door design.
- Models with the suffix -20S are double deck units.
- Energy Star approved (Suffix -ESS)
- UL, CUL Gas-Fired and NSF listed.

Note: Ovens supplied with casters must be installed with an approved restraining device.



Sunfire SCO Series Gas Convection Oven

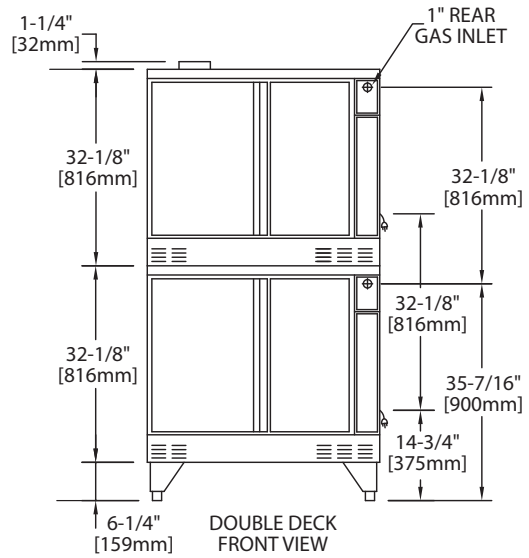
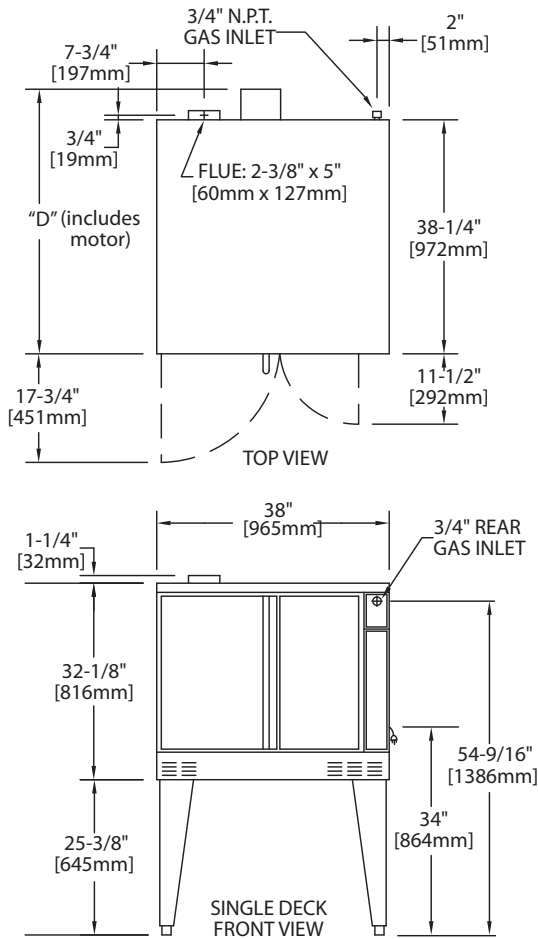

Gas Input Ratings shown here are for installations up to 3,000 ft. (915m) above sea level. Specify altitudes over 3,000 ft.

Notes:

Standard electrical specifications include motor requirements.

(120V units) 115V, .6 HP, 1670 rpm; 2-speed motor option, 1430 and 1670 rpm, 60Hz.

A 6 ft. line cord is provided for each 120V deck with a (NEMA #5-15P) plug.

It is recommended a separate 15 AMP circuit for each 120V unit.

Models	Int. Dimensions : In (mm)			Ext. Dimensions: In (mm)			Ship Wt Lbs/kg	Ship Dim. Cubic Ft.
	W	H	D	W	H	D (w/motor)		
Single Deck	29 (736)	24 (610)	24 (610)	38 (965)	57-1/2 (1461)	41-1/4 (1048)	515/230	64
Double Deck	29(736)	24(610)	24(610)	38(965)	70-1/2 (1791)**	41-1/4 (1048)	1030/465	128

** Height with or without with standard casters. Height with low profile casters (double deck) is 68-1/2" (1740mm).

Models	Input Ratings, Natural Gas			Operating Pressure	Electrical Specifications
	BTU/hr	kW Equiv.	Gas Inlet		
Single Deck	53,000	15.53	(1) @ 3/4" NPT	4.1" WC	(1)@9.8A
Double Deck	106,000	31.06	(1) @1" NPT		(2)@9.8A

*Maximum Pressure 13.8" WC @ 70°F (21°C)

Many local codes exist and it is the responsibility of the owner and installer to comply with those codes. These appliances are intended for commercial use by professionally trained personnel.

Installation Notes:			
Combustible & Non-Combustible Wall Clearances:		Entry Clearances In (mm)	
Sides	Rear	Crated	Uncrated
*1" (25mm)	3" (76mm)	47" (1194mm)	32-1/2" (826mm)

*Note: Installations beside units with high heat sources it is recommended to leave 6" (152mm) on the right side of oven. Refer to the installation manual for more detail

Welbilt reserves the right to make changes to the design or specifications without prior notice.