

PRODIGY[®] ELITE

MC0722 - 700lb Cube Ice Machine

Prodigy ELITE[®] Modular Cube Ice Machine

ENHANCED RELIABILITY

Integrated ICELINQ[®] App

Provides real-time diagnostics, access to settings and guided cleanings. The app also contains specific information for convenient maintenance.

Upgraded Sensors

Ice thickness and water sensor design enhances cleanability and amplifies durability.

Preservation Mode

Maximizes uptime and notifies users of potential issues.

EASE OF USE

AutoAlert[™] Panel

The AutoAlert[™] panel displays relevant machine status that is visible across the room. Now featuring an external bin full indicator light and easier to read 16-segment display.

SANITARY DESIGN

Removable, External Air Filters

Speeds up cleaning process and reduces unit footprint.

WaterSense Adaptive Purge

Optimizes water consumption, keeping the machine cleaner and operating more efficiently.



Compatible with ICELINQ[®]



The ICELINQ[®] app simplifies interaction with machine via Bluetooth[®] connection



Intelligent sensor technology maximizes efficiency and lowers operating costs



24 Hour Volume Production

Air Cooled

70°F/21°C 50°F/10°C	Air Water	90°F/32°C 70°F/21°C
758/345 lb/kg		566/257 lb/kg



Modular Bin Options



MC0722 on ID150

Model Number*	Dimensions W" x D" x H"	Bin Application		Ship Weight lb/kg
		Capacity lb/kg	Finish	
B842S	42 x 34 x 44	778/353	Metallic	190/86
B948S	48 x 34 x 44	893/406	Metallic	209/95
ID150	22 x 30 x 35.63	150/68	Metallic	150/68

* Contact Scotsman for bin top requirements.



Cube Ice

Common ice form, ideal for mixed drinks.



Small Cube
7/8" x 7/8" x 3/8"
(2.22 x 2.22 x .95 cm)



Medium Cube
7/8" x 7/8" x 7/8"
(2.22 x 2.22 x 2.22 cm)



Certification



Warranty

- 3 Years parts and labor on all components.
- 5 Years parts and labor on the evaporator.
- 5 Years parts on the compressor and condenser.
- Warranty valid in North, South & Central America for commercial installations.
- Contact factory for warranty in other regions.
- Residential Applications: 1 year parts and labor

Scotsman[®]

101 Corporate Woods Parkway, Vernon Hills, IL 60061

1-800-SCOTSMAN | Fax: 847-913-9844 | www.scotsman-ice.com | customer.relations@scotsman-ice.com

MC0722 - 700lb Cube Ice Machine

MC0722 - 700lb Cube Ice Machine

Prodigy ELITE® Modular Cube Ice Machine

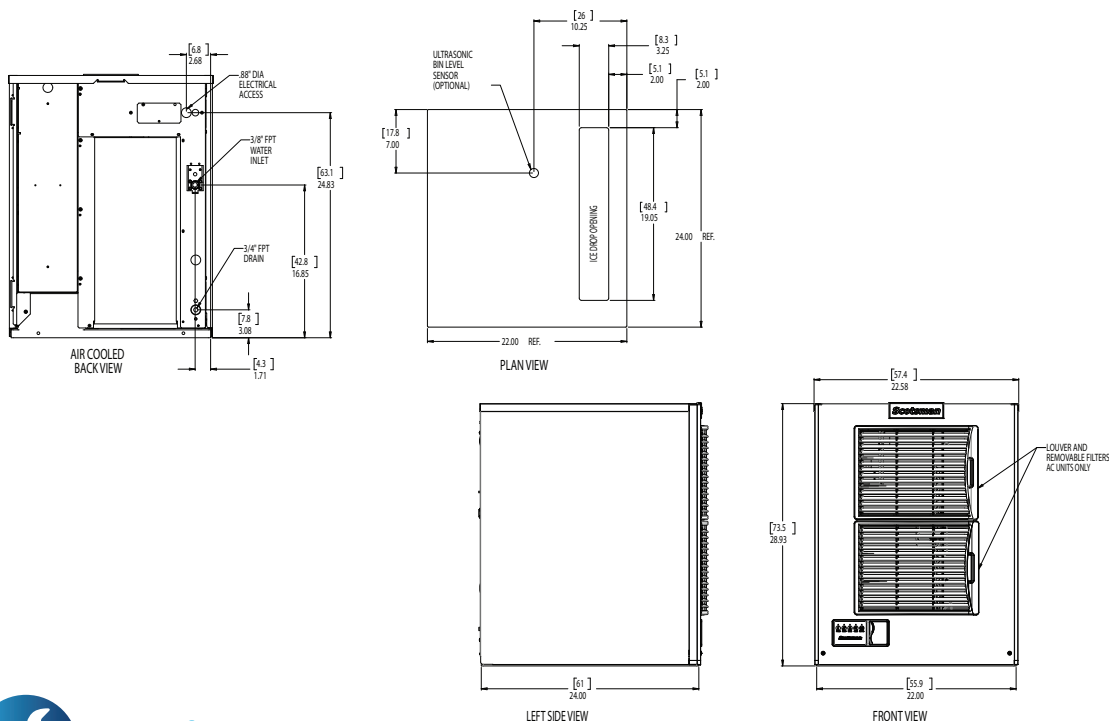

Specifications

Model Number	Condenser Unit	Basic Electrical Volts/Hz/Phase	Max. Fuse Size or HACR Circuit Breaker (amps)	Circuit Wires	Min. Circuit Ampacity	Energy Consumption kWh/100 lb (45.4 kg) 90°F(32°C)/70°F(21°C)	Water Usage Gallons/100 lb (liters/45.4 kg)	
							Potable 90°F(32°C)/70°F(21°C)	Condenser 90°F(32°C)/70°F(21°C)
— MC0722MA-32	Air	208-230/60/1	15	2	11.0	5.26	18.0/68.1	-
— MC0722SA-32	Air	208-230/60/1	15	2	11.0	5.26	18.0/68.1	-



All Models

Dimensions (W x D x H):

Unit: 22" x 24" x 29" (55.9 x 61.0 x 73.7 cm)

Shipping Carton: 26" x 28" x 35" (66 x 71.1 x 88.9 cm)

Shipping Weight: 189 lb / 86 kg BTUs per hour: 12,750

Refrigerant: R-404A



Accessories

Model Number	Description
KVS	Vari-Smart™ Ice Level Control - Precisely control ice levels using ultrasonic technology.
KBILC	Basic Ice Level Control - Thermistor technology, ideal for dispenser applications.
KSBU	Smart-Board™ Advanced Control - Use additional operational data for fast diagnosis.
KSBU-N	Smart-Board™ Advanced Control with Network - Network capable.
KPAS	Prodigy Advanced Sustainability Kit - Includes KVS and KSBU - N
XR-30	XSafe® Sanitation System for Modular Cube - Continuous operation, field-installed.

Scotsman recommends all ice machines have water filtration. See Scotsman water filter specification sheet for details.



Operating Requirements

	Minimum	Maximum
Air Temperatures	50°F (10°C)	100°F (38°C)
Water Temperatures	40°F (4.4°C)	100°F (38°C)
Remote Cond. Temps	-20°F (-29°C)	120°F (49°C)
Potable Water Pressure	20 PSIG (1.4 bar)	80 PSIG (5.5 bar)
Cond. Water Pressure	20 PSIG (1.4 bar)	230 PSIG (16.1 bar)
Electrical Voltage	-5%	+10%

Specifications and design are subject to change without notice.