



Simply Engineered Better

SW

Pass Through Fully Automatic Glasswashing Machine



SW600

SW400

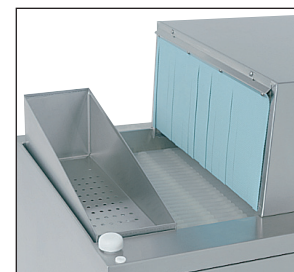

SW47

SPECIFIER STATEMENT

Specified unit will be Moyer Diebel model SW400 or SW600 pass-through conveyor type glasswasher.

Features include detergent, sanitizer and rinse aid pump, upper & lower wash/rinse arms, cold water final rinse, polypropylene conveyor, two splash curtains, processes 2,000 glasses/hr. Warranty: 1 year parts, 90 day labor.



Project _____
 Item No. _____
 Quantity _____

SW GLASSWASHING MACHINE

STANDARD FEATURES

- New three pump injection system:
 - Injector system allows the use of separate sanitizer and rinse aid resulting in real savings.
 - Precisely calibrated pumps inject just the right amount of chemical each time – no guesswork –no waste.
- Upper and lower wash and rinse arms produce sparkling clean glasses every time
- Cool final rinse water provides a fresh, cool glass ready for immediate use
- Available in either 4 foot or 6 foot models
- Two splash curtains
- Processes approximately 2000, 2-1/2" glasses/hr.
- Available in either right-to-left or left-to-right operation
- Polypropylene conveyor virtually eliminates chipping of fine stemware.

OPTIONS & ACCESSORIES

- | | |
|--|-------------|
| <input type="checkbox"/> SW46C – Waste Sink | P/N 0708453 |
| <input type="checkbox"/> SW47 – Drain Tray & Waste Collector | P/N 0706204 |
| <input type="checkbox"/> SW12 – S/S splash guards for SW400 | P/N 0702877 |
| <input type="checkbox"/> SW24 – S/S splash guards for SW600 | P/N 0702878 |
| <input type="checkbox"/> SW48 – S/S back panel for SW400 | P/N 0702882 |
| <input type="checkbox"/> SW72 – S/S back panel for SW600 | P/N 0702886 |
| <input type="checkbox"/> Kit 264 – Washdown hose | P/N 0701956 |
| <input type="checkbox"/> Kit 332 – Casters; set of 4,
2 locking, 2 stationary | P/N 0701962 |
| <input type="checkbox"/> Site Glass kit | P/N 0712993 |

MD007 Printed in U.S.A.

Moyer Diebel –Canada

2674 North Service Rd., Jordan Station, Ontario, Canada L0R 1S0 Tel: 905/562-4195 Fax: 905/562-4618
 800/263-5798 sales@moyerdiebellimited.com





Simply Engineered Better

SW

Pass Through Fully Automatic
Glasswashing Machine

Dimensions shown in inches and [millimeters]

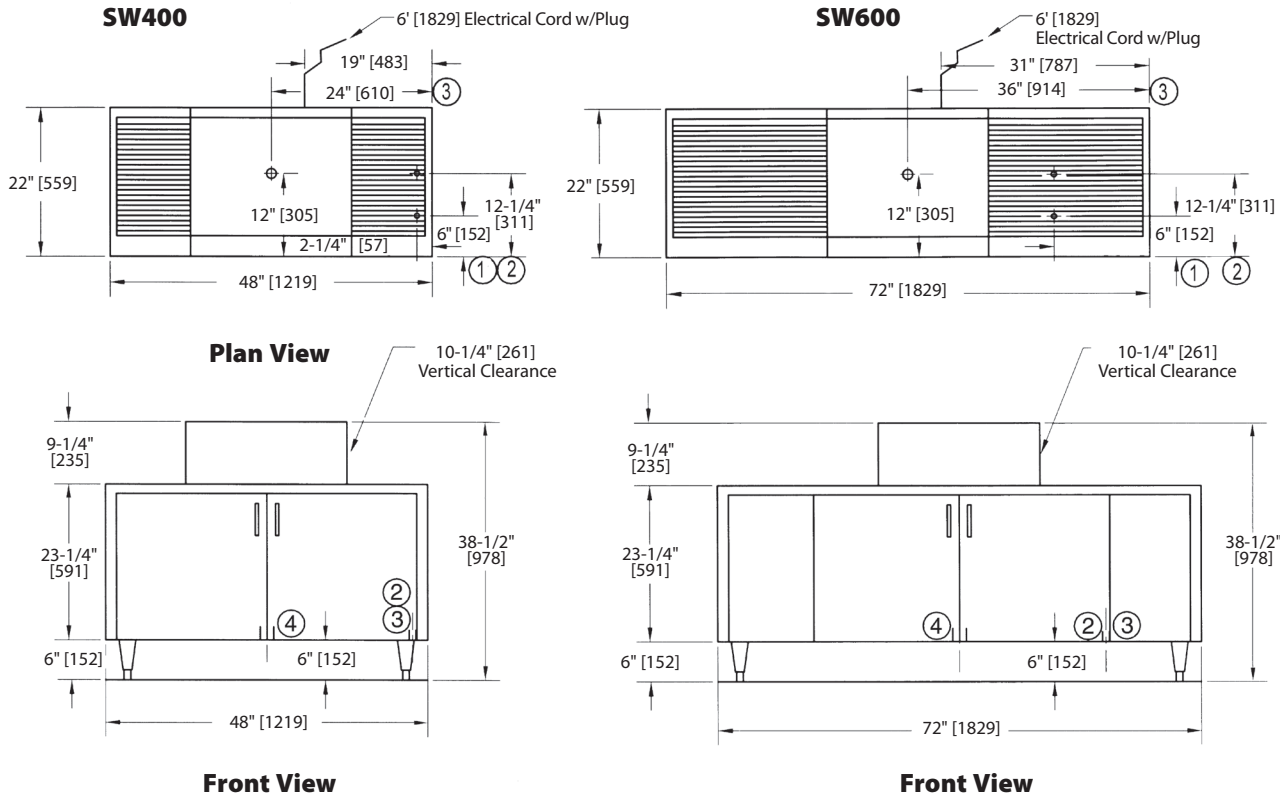

NOTE: Both Doors: 21-1/2" [546] High
22" [559] Wide

Utilities	
1 Electrical	208 - 230/60/1, 15 amp (Supplied with 4ft. [1219] plug-in cord NEMA6-15P)
2 Hot Water Connection	1/2" IPS. Flow pressure 25-95 psi (173-656 kPa)
3 Cold Water Connection	1/2" IPS. Flow pressure 25-95 psi (173-656 kPa)
4 Drain Connection	1/2" IPS. Flow pressure 25-95 psi (173-656 kPa) 1-1/2" tailpiece. Connect to drain size according to local plumbing code.

	Uncrated		Crated	
	SW400	SW600	SW400	SW600
Height*	38-1/2" [978]	38-1/2" [978]	49" [1244]	49" [1244]
Width	48" [1219]	72" [1882]	53" [1346]	76-1/2" [1942]
Depth	22" [559]	22" [559]	27-1/2" [698]	27-1/2" [698]
Ship Wt. lbs/kg	225/102	285/129	255/115	325/147

* Adjustable foot height - 1-1/4" [32]

SPECIFICATIONS

Capacity	2-1/2" glasses/hr.	2000
Water Consumption	Cold water	2.8 US gpm 10.6 liters/min 2.24 imp. gpm
	Hot water (initial fill)	3 US gallons 11.35 liters
	(Max. use-approx. 10 US gph/8.3 imp gph)	2.4 imp. gallons
Temperatures °F/C	Inlet water (hot)	140-160/60-71
	Inlet water (cold)	75/24
Heating	Tank heat, electric (kW)	3
Conveyor	Speed inches/millimeters per min.	14/356

Warning: Plumbing and electrical connections should be made by qualified personnel who will observe all the applicable plumbing, sanitary and safety codes.