

**Project:**

**Item Number:**

**Quantity:**

**FROZEN UNCARBONATED BEVERAGE DISPENSERS**



**DESCRIPTION**

Stoelting's Frozen Uncarbonated Beverage Dispensers mix and serve a variety of frozen beverages including margaritas, granitas, slushes, coffee drinks, and dairy-based products. They are the ideal choice for bars and restaurants looking for flexibility, capacity and simple operation in a compact footprint.

**ITEMS**

**Standard Capacity**

- A118-37
- A118-37-AF
- A118-37-L
- A118-38
- A118-38-L
- A118-17
- A118-17-L
- A118-18
- A118-18-L

**High Capacity**

- D118-37
- D118-37-L
- D118-38
- D118-38-AF
- D118-38-L
- D118-38-L-AF
- D118-17
- D118-17-L
- D118-18
- D118-18-L
- D118-18-L-AF

**FEATURES**

- Push/Pull self-closing handle for easy, single hand operation
- Extremely quiet, lowest dbA in industry
- Base tray accommodates full-size, 32 oz. pitcher
- Large capacity, high volume drink production
- Can be configured to serve a variety of drinks
- Compact design requires zero clearance at the back, sits flush to the wall to allow for optimal countertop usage
- Customizable illuminated billboard space
- LED illuminated clear window showcases drinks
- Available in air-cooled or water-cooled
- Mix level indicator
- Single switch for simple operation and cleaning
- Integrated hopper cover prevents accidental spills in the hopper
- Torque cutoff prevents freeze-up
- 6 ft. (182.9 cm) cord with plug



Every machine includes Stoelting's White Glove Service. One call does it all – customer service, technical service, parts or warranty information, installation, startup, sales, on-site service dispatch and much more. Available 24 hours a day, seven days a week year-round.

**WARRANTY:** Five years on major components; One year on labor and non-wear parts.

Continuous research leads to ongoing product improvements; therefore, these specifications are subject to change without notice and should not be used as installation specifications.

Approvals	Date

# FROZEN UNCARBONATED BEVERAGE DISPENSERS

## DIMENSIONS (shown in inches (cm))

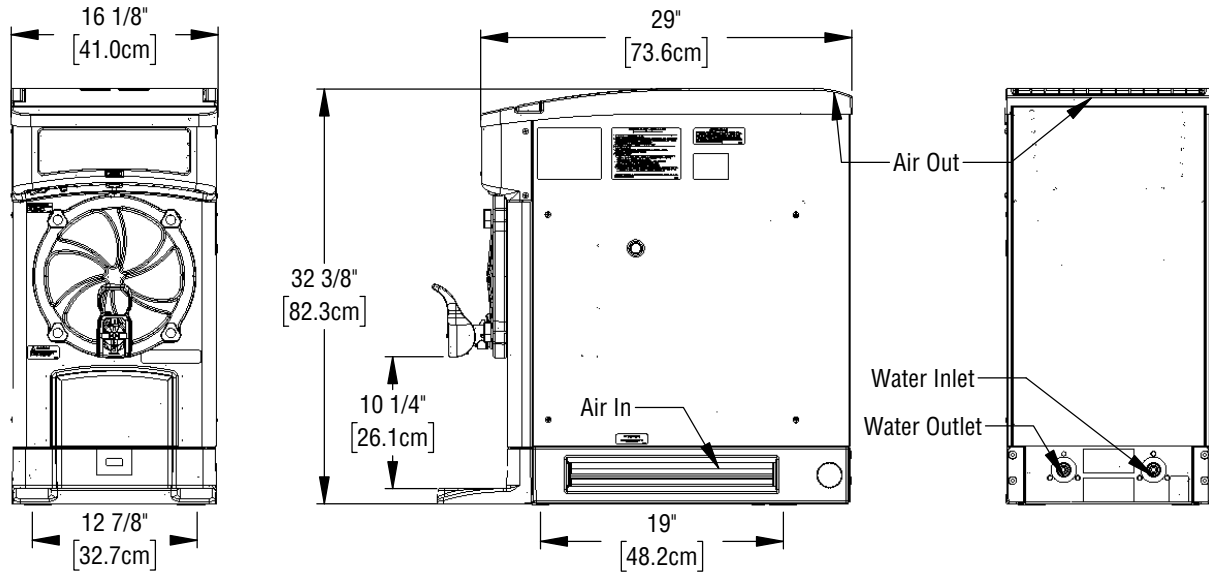

## GENERAL SPECIFICATIONS

Item No.	Capacity			Compressor (Btu/hr)	Weight Lb (Kg)	Crated Weight Lb (Kg)	Dimension in (cm)		
	Hopper Gal (L)	Freezing Cylinder Gal (L)	Number of 32 Oz. Pitchers (per hour)				Width	Height	Depth
A118	5	2	32	4,250	210	240	16 1/8	32 3/8	29
D118	(18.9)	(7.6)	60	8,250	(95.3)	(108.8)	(41.0)	(82.2)	(73.7)

Air cooled models are zero clearance at back, but require 3" (7.6 cm) clearance at the sides.

Water cooled machines are zero clearance at back and sides. They require 1/2" N.P.T. water and drain fittings.

## ITEM NUMBER SPECIFICATIONS

Item No.	Cooling	Volts	Hz	Phase	Running Amps	Plug	Lighted Door	Auto Fill
A118-37	Air	115	60	1	10.2	NEMA 5-20P	—	—
A118-37-AF							—	✓
A118-37-L							✓	—
A118-38	Air	208-240	60	1	4.7	NEMA 6-20P	—	—
A118-38-L							✓	—
A118-17	Water	115	60	1	10.2	NEMA 5-20P	—	—
A118-17-L							✓	—
A118-18	Water	208-240	60	1	4.7	NEMA 6-20P	—	—
A118-18-L							✓	—
D118-37	Air	115	60	1	13.6	NEMA L5-30P	—	—
D118-37-L							✓	—
D118-38	Air	208-240	60	1	8.6	NEMA 6-20P	—	—
D118-38-AF							—	✓
D118-38-L							✓	—
D118-38-L-AF							—	✓
D118-17	Water	115	60	1	13.6	NEMA L5-30P	—	—
D118-17-L							✓	—
D118-18	Water	208-240	60	1	8.6	NEMA 6-20P	—	—
D118-18-L-AF							✓	✓
D118-18-L							✓	—



**Main Phone**  
 800-319-9549 (U.S. Toll Free)  
 920-894-2293 (Outside the U.S.)  
 www.stoeltingfoodservice.com  
 www.vollrath.com