



Job _____ Item No. _____

Notes: _____

Tabletop Planetary Mixer

Model Number: SM200

Planetary Mixer

SPECIFICATIONS



FEATURES

- Includes 20 QT Stainless Steel Bowl, Dough Hook, Wire Whip, Ingredient Chute, and Flat Beater
- 3 Speeds: Low (107 RPM), Medium (198 RPM), High (361 RPM)
- 60 Minute Countdown Timer
- Thermal Overload Protection for Motor
- #12 Hub for Attachments
- Manual Bowl Lift
- Easy to Clean White Powder Coating
- Emergency Stop

DESCRIPTION

The SM200 Planetary Mixer is designed as a solution to fill a bakers needs. Compact, heavy duty, and versatile. It sets itself as a perfect mixer for doughs, pastries, meringues and more. Simple to operate controls and has a capacity of up to 20 Quarts.

SHORT FORM SPECIFICATIONS

Mixer, Planetary, Electric, General Purpose, 20 Quart, Three adjustable speeds, 60 minute countdown timer, Manual bowl lift, Thermal overload production for motor, Comes standard with 20 Quart bowl/beater/whip, #12 hub included (attachments sold separately), Wire guard for bowl featuring motor cutoff switch, On year labor and two year parts warranty

WARRANTY

The SM200 comes with a one year warranty for parts and two year warranty for labor.

OPTIONS AND ACCESSORIES

- SM100HV: Meat Grinder Attachment
- SM100CL: Vegetable & Pepperoni Slicer with 3 Cheese Shredding Plates
- Equipment Stand (SM200T)

CERTIFICATIONS

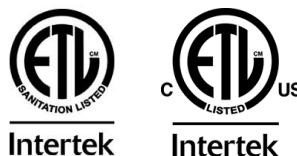

Doyon/NU-VU

5600 13th Street, Menominee, MI 49858

Phone 800.338.9886 • Fax 906.863.5889

www.doyon.qc.ca

Follow Us



SPECIFICATIONS

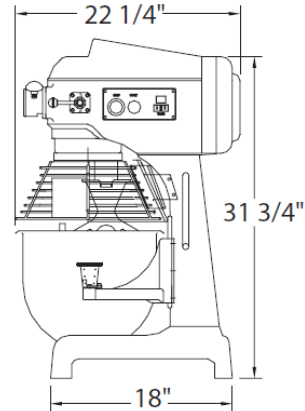
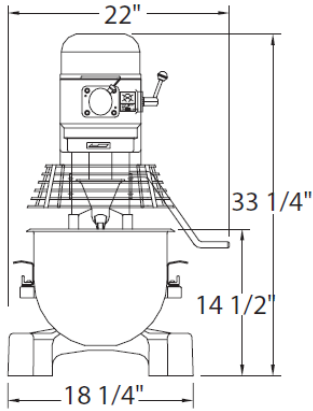

CLEARANCES

The top and bottom of the mixer must remain open and unobstructed. A clearance of at least 6" (152mm) must be maintained around sides .

ELECTRICAL DATA

Single electrical connection,
120V, 1440 watts, 12A, 60Hz,
single phase, NEMA 5-15P plug.



Model	Speeds (RPM)			Dough Capacity (50% AR)	HUB	Motor (HP)	Height [A]		Depth [B]		Width [C]		Weight	
	1st	2nd	3rd				in	mm	in	mm	in	mm	lbs	kg
SM200	107	198	361	10 lb (4.5 kg)	Yes	1/2	22	559	22 1/4	565	33 1/4	845	250	114

Due to periodic changes in designs, methods, procedures, policies and regulations, the specifications contained in this sheet are subject to change without notice. While Doyon/NU-VU exercises good faith efforts to provide information that is accurate, we are not responsible for errors or omissions in information provided or conclusions reached as a result of using these specifications. By using the information provided, the user assumes all risks in connection with such use.

Doyon/NU-VU

5600 13th Street, Menominee, MI 49858

Phone 800.338.9886 • Fax 906.863.5889

www.doyon.qc.ca



Printed in the USA • SM200 • Rev. B • 3.2021
Specifications are subject to change without notice
and are not intended for installation purposes.