

# SF28M

## Froze Space Merchandiser™

Project Name: \_\_\_\_\_

Item #: \_\_\_\_\_ Quantity: \_\_\_\_\_



Width*	Depth**	Height***	Shelves	Cold Space™	Ship Weight	Ship Cube	Cooling Capacity	Electrical
30 1/2" 775 mm	31" 788 mm	78" 1982 mm	3	28	342 lbs 155 kg	49 cu. ft 1.39 m <sup>3</sup>	3/4 HP	115V/10 Amp/60 Hz - Single Phase - NEMA 5-15P, Dedicated Circuit

\*\* Add 1 1/2" (39mm) for Handle. \*\*\* Add 3/8" (10mm) for Threaded-In Levelers. Millimeters rounded up.

Shipped less Graphics. Custom Graphics Optional.

### Premium Features



ProductTemp™



Digitally Controlled

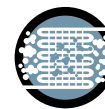

Lint Tolerant Condenser Coil



LED Lighting System

 Automatic Stainless Steel  
Condensate Control System

Priority Air-Flow

## SF28M: Designed to optimize merchandising experience to the highest standards of quality and performance.

### Refrigeration:

- Traditional non-removable, split forced-air refrigeration system employs R-404a refrigerant within a sealed capillary tube system.
- Condensing unit is bottom-mounted and can be accessed from the front for ease of maintenance.
- Priority, directed air flow provides optimum cooling and energy efficiency through front of unit for optimized heat exchange ventilation.
- Lint-Tolerant Design with wide spaced fins, maximizes airflow over the compressor and minimizes build-up of dust and lint.
- Corrosion resistant coated evaporator coil.
- Automatic, stainless steel condensate control system.
- Equipped with Energy Efficient Digital Controller featuring visual/audible product protection alarm. Freezers factory preset for -23.3°C (-10°F).
- Technologically advanced ProcuTemp™ provides exterior product temperature display. Displays to a resolution within 1°.
- Energy-Saving, Time-Initiated, Temperature-Terminated Defrost System with Evaporator Fan Motor Delay during Defrost and Fan Motor Interrupt on Door Opening. Features Manual Defrost Override.
- Low Energy Cabinet Mullion Heater prevents frosting.
- Quality, self-lubricating and sealed motors with streamlined air-flow provide quieter yet robust refrigeration.
- Equipped with Digital Thermometer.

### Cabinet:

- Exterior – durable appliance white.
- Interior – NSF approved white aluminum liner with stainless steel floor.
- Ergonomic raised interior floor.
- Insulation – cabinet is foamed-in-place with eco-conscious, polyurethane insulation.
- Heavy duty thread-in leveler legs.

### Doors:

- Self-Closing Swing Doors feature hold-open position, and spring-back protection.
- Magnetic gaskets are single piece bead-mount construction easily removable for cleaning.
- Low energy, heated and insulated safety glass with black extruded frame, prevents frost.
- Durable, external door handle(s).

### Lighting:

- Energy Efficient LED Lighting System for crisp Illuminated Signage and Interior Display, on Switch.

### Storage:

- Six (6) white coated shelves 26 1/4"W x 22"D (667mm x 559mm), are NSF approved.
- Heavy duty aluminum shelving pilasters will not peel or chip adjustment of 1/2" (13mm) increments.

### Electrical:

- Factory power cord installed for connection to a sole-use (dedicated) 115V/60Hz/1-Phase, 15 Amp circuit.

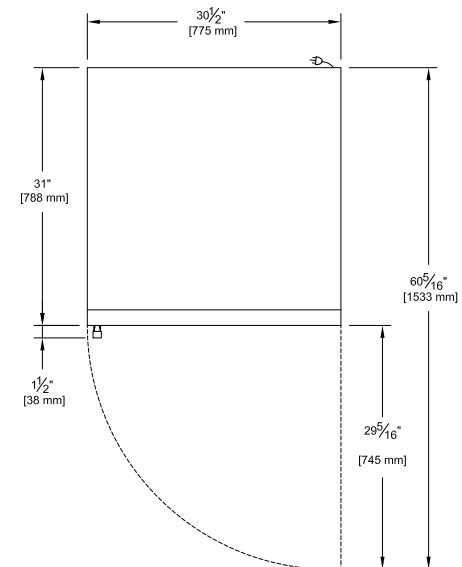
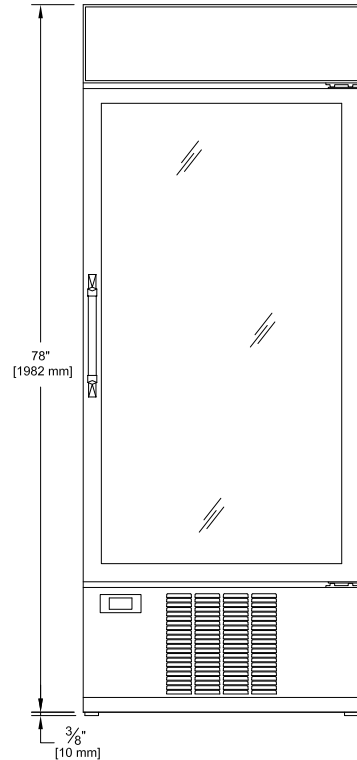

<p><b>Special Inspection by CSA International</b></p>			
---	--	--	--

HABCO MANUFACTURING INC. 501 GORDON BAKER ROAD, TORONTO, ONTARIO, CANADA, M2H 2S6  
 Toll Free CAN: 1-800-387-5398 USA: 1-800-448-0244 Fax: 416-491-6982 www.habcomfg.com