

SF24HCSX

Stainless Xterior™ Freezer

Project Name: _____

Item #: _____ Quantity: _____



Width*	Depth**	Height***	Shelves	Cold Space™	Ship Weight	Ship Cube	Cooling Capacity	Electrical
23 7/8" 607 mm	31" 788 mm	78" 1982 mm	3	24	275 lbs 125 kg	41 cu. ft 1.16 m ³	1/3 HP	115V/6.8 Amp/60 Hz - Single Phase - NEMA 5-15P, Dedicated Circuit

*** Add 3/8" (10mm) for Threaded-In Levelers. Millimeters rounded up.

Premium Features



ProductTemp™



Digitally Controlled



LED Lighting System



Finless Free&Clear™
Condenser Coil



Automatic Stainless Steel
Condensate Control System



Priority Air-Flow

SF24HCSX: Designed to enhance the refrigerated storage or display experience to the highest standards of quality and performance.

Refrigeration:

- Advanced variable speed compressor for extended operational life and improved energy efficiency.
- Split forced-air refrigeration system employs R290 refrigerant within a sealed capillary tube system.
- Condensing unit is bottom-mounted and can be accessed from the front for ease of maintenance.
- Priority, directed air flow provides optimum cooling and energy efficiency through front of unit for optimized heat exchange ventilation.
- Finless, Free&Clear Condenser Coil maximizes air-flow over compressor, reduces energy consumption and is non-clogging.
- Corrosion resistant coated evaporator coil.
- Automatic, stainless steel condensate control system.
- Equipped with Energy Efficient Digital Controller featuring visual/audible product protection alarm. Freezers factory preset for -23.3°C (-10°F).
- Technologically advanced ProducTemp™ provides exterior product temperature display. Displays to a resolution within 1°.
- Energy-Saving, Time-Initiated, Temperature-Terminated Defrost System with Evaporator Fan Motor Delay during Defrost and Fan Motor Interrupt on Door Opening. Features Manual Defrost Override.
- Quality, self-lubricating and sealed motors with streamlined air-flow provide quieter yet robust refrigeration.
- Equipped with Digital Thermometer.

Cabinet:

- Exterior – stainless steel front and sides.
- Interior – NSF approved white aluminum liner with stainless steel covered corner floor.
- Ergonomic raised interior floor.
- Insulation – cabinet is foamed-in-place with eco-conscious, polyurethane insulation.
- Heavy duty thread-in leveler legs.

Doors:

- Self-Closing Swing Doors feature hold-open position, and spring-back protection.
- Magnetic gaskets are single piece bead-mount construction easily removable for cleaning.
- Stainless steel front with white aluminum interior liner and large grip, recessed handle(s)

Lighting:

- Energy efficient LED lighting system for sparkling Illuminated Interior Display, on Switch.

Storage:

- Five (5) white coated shelves 18 1/2"W x 22 3/4"D (470mm x 578mm) are NSF approved.
- Heavy duty aluminum shelving pilasters will not peel or chip adjustment of 1/2" (13mm) increments.

Electrical:

- Factory power cord installed for connection to a sole-use (dedicated) 115V/60Hz/1-Phase, 15 Amp circuit.

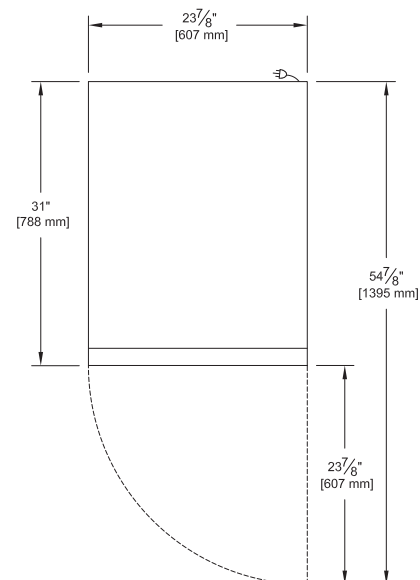
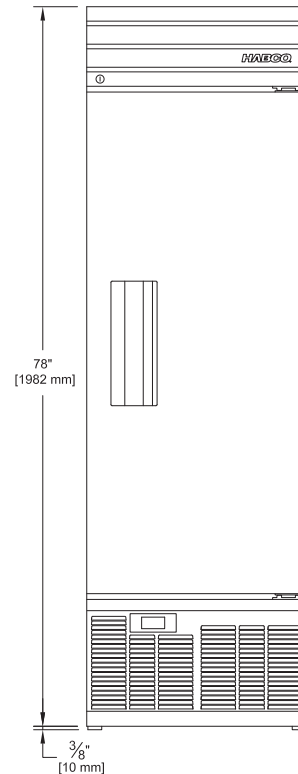

HABCO MANUFACTURING INC. 501 GORDON BAKER ROAD, TORONTO, ONTARIO, CANADA, M2H 2S6
 Toll Free CAN: 1-800-387-5398 USA: 1-800-448-0244 Fax: 416-491-6982 www.habcomfg.com

HABCO Manufacturing Inc. HABCO is a registered trade mark of HABCO Manufacturing Inc. in Canada, USA, U.K. and Germany. HABCO logo design, Built to Perform. Crafted to Last. and CASSETTE are registered trademarks of HABCO Manufacturing Inc. in Canada and U.S.A. Additional trade marks may be employed by HABCO and have been duly noted with respective registration mark or trade mark symbol. DOMESTIC AND INTERNATIONAL PATENTS.