



REFRIGERATION

SERVING THE FOOD INDUSTRY SINCE 1951

OPEN REFRIGERATED FLOOR DISPLAY CASE - 250L

Item: 25825

Model: RS-CN-0250



FEATURES:

- LED lighting
- Digital temperature controls
- Pull down curtain
- Adjustable shelf positions
- Casters

TECHNICAL DRAWING & DIMENSIONS

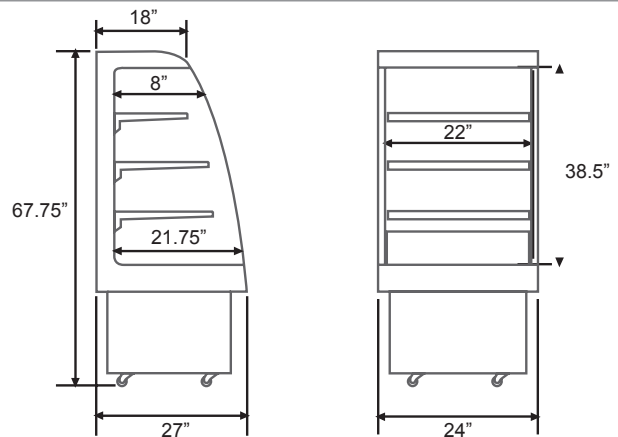

TECHICAL SPECIFICATION

ITEM NUMBER	25825	BLOWING GAS	XPS
MODEL	RS-CN-0250	TYPE OF CLIMATE	6
RATED INPUT POWER	650W	RATED CURRENT (A)	10
ELECTRICAL HEATING ELEMENT	400W	WEIGHT	282 lbs.
CAPACITY (L / CU. FT.)	252 L / 8.9 cu. ft.	PACKAGING WEIGHT	298 lbs.
ELECTRICAL	110V/60/1	DIMENSIONS (WDH)	27" x 24" x 67.75"
LAMP POWER (W)	1.44*4 (LED)	INNER DIMENSIONS	21.75" x 22" x 38.5"
TEMPERATURE RANGE	2 - 10°C	SHELF SIZE	15" x 21.75" (2pc.) 12" x 21.75" (1pc.)
REFRIGERANT & INJECTION	R134a (600g)	PACKAGING DIMENSIONS	30" x 28" x 70"

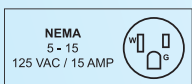

OMCAN INC.

Telephone: 1-800-465-0234

Fax: (905) 607-0234

E-mail: sales@omcan.com

Website: www.omcan.com



Follow us to keep up to date with the latest news and offers



2015.E.O.E