

efi sales Ltd.

Equipment for the Foodservice Industry
value + quality + service

Convection Oven

RCTCV-1



RCTCV-1

Features

Features:

- Linked stainless steel door, double tempered glass window, built-in light.
- Five nickel plated grab-and-go oven racks with thirteen rack positions.
- Porcelain enamel on steel oven interior with four circular arc corners, easy to clean.
- Computer version of the automatic ignition module, automatic temperature control with energy saving and environmental protection.
- Timed reminders
- Two-speed circulation heating way with even temperature in the oven to ensure food color.

- Two-stage wind speed control fire, easy to operate.
- Oven cooling switch for quick cooling.

Warranty:

- one year parts and labour;
- Specifications subject to change without notice.



RCTCV-1

Specifications

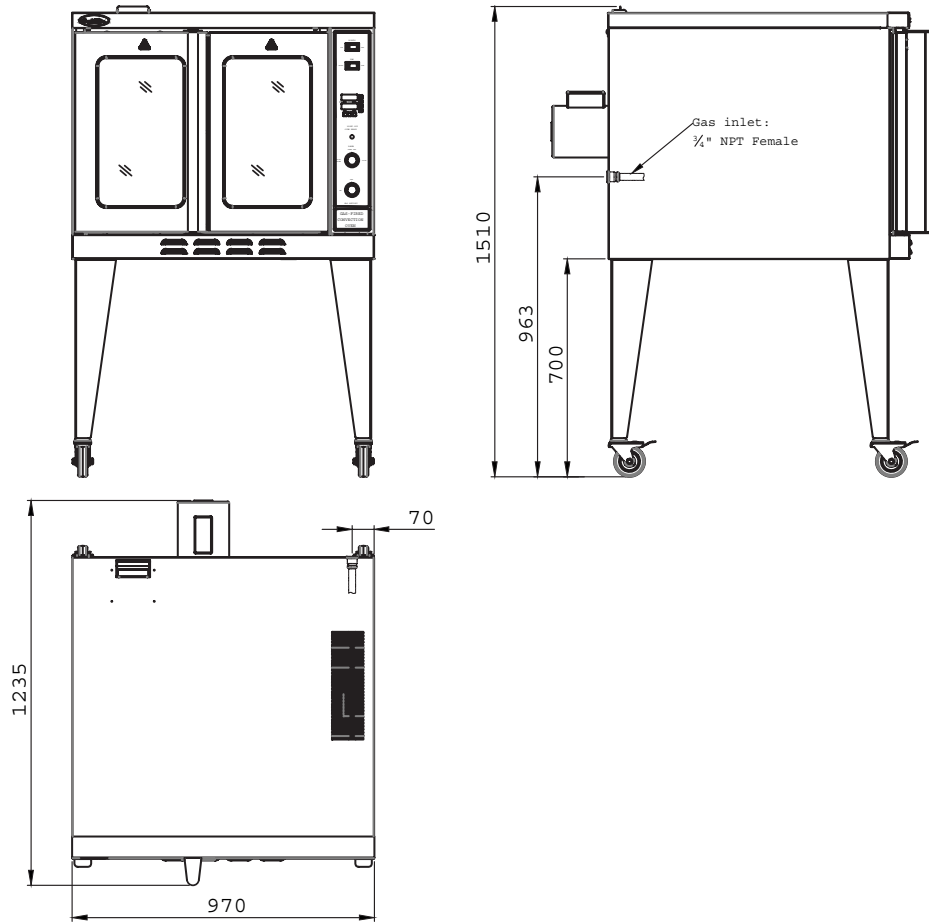

Model	Size	GAS PRESSURE	VOLTS	HZ.	AMPS	PH.	AT INLET	AT MANIFOLD	PER BURNER	PER OVEN	INJECTOR
RCTCV-1N	970×1235×1510 mm	NATURAL GAS	115	60	8.5	1	13.84 in.W.C./3.45kPa	3.5 in.W.C./0.87kPa	23,000 BTU/HR	46,000 BTU/HR	43# (φ2.26mm)
RCTCV-1P		PROPANE GAS						10 in.W.C./2.49kPa			54# (φ1.40mm)