

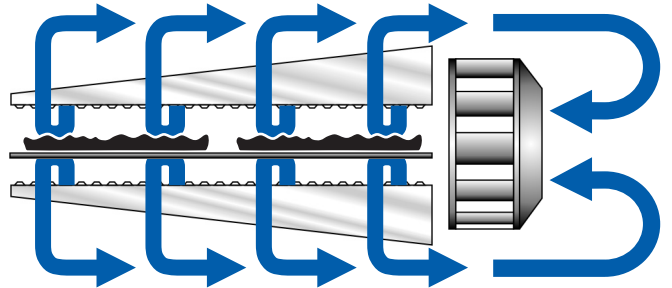

PATENTS PENDING

Principle

The Middleby Marshall WOW!2 conveyor series oven utilizes advanced VAF impingement technology that allows the user full control of the air flow on the top and bottom of the baking chamber, resulting in optimal results in cooking product. Air flow is modified through the main control, allowing instant results and full control of air movement, time, and temperature settings. The exterior of the oven is cool to the touch, safely giving users cooler working conditions in the immediate area. The WOW!2 oven is designed to cook an endless amount of food products including pizza, chicken, seafood, sandwiches and more.



Standard Features

- **Impingement PLUS!** low oven profile and dual air return
- **Patented EMS energy Management System** reduces gas consumption and increases cooking efficiency
- 38" (1029mm) long cooking chamber
- 25"(635mm) wide, 65 1/4"(1656mm) long conveyor

belt **Speed**

- Advanced technology air delivery system bakes up to 30% faster than standard conveyor ovens

Energy Management System

The PS638WOW!™ oven features an Energy Management System (EMS) that significantly reduces gas consumption. Touch Screen Control can be programmed in one energy saving mode. Automatic "energy eye" puts oven in "sleep mode" when no food is in the oven, automatically saving energy.

Optional Features

- Split belt - two 12" (305mm) belts with individually adjustable speed settings

Cleanability

PS638 Ovens are designed for easy cleaning. Removable parts include: crumb pans, end panels, air fingers, and a folding conveyor belt assembly.

Easily Serviced

Control compartment is designed for quick and easy access.

Warranty

All PS638 models have a one year parts and labor warranty. Oven start-up is included at no additional charge (USA Only). Factory demo available at additional charge

Ventilation

For installation under a ventilation hood only.

*Patent Pending



PS638G Rev 2 2/18

PS638-1

TOP VIEW

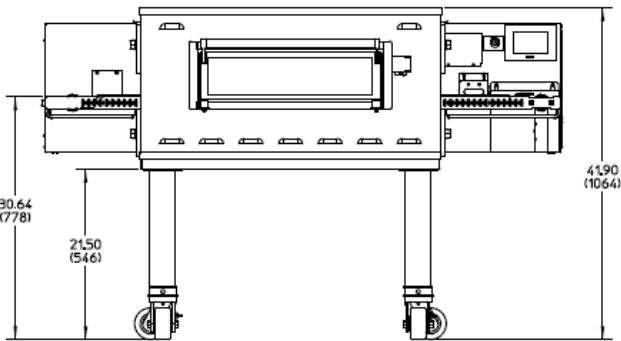
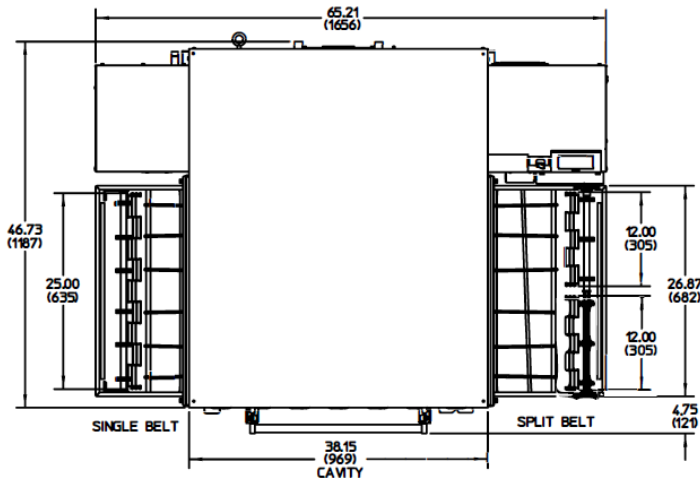

FRONT VIEW

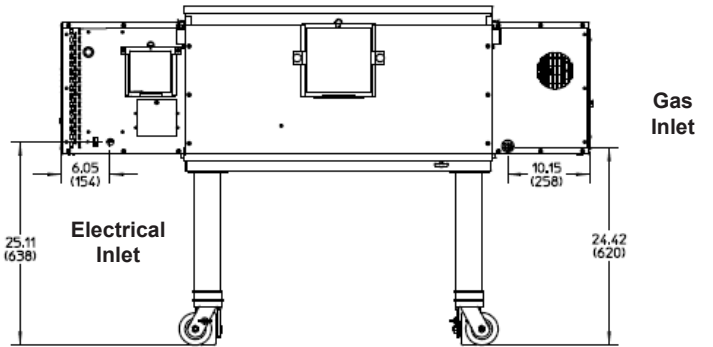

BACK VIEW

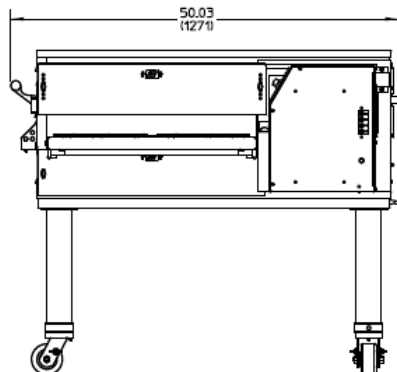

SIDE VIEW

**PS638 Series
Direct Gas Fired Conveyor Oven**

NOTE: Drawings show ovens equipped with casters.

PS638-2

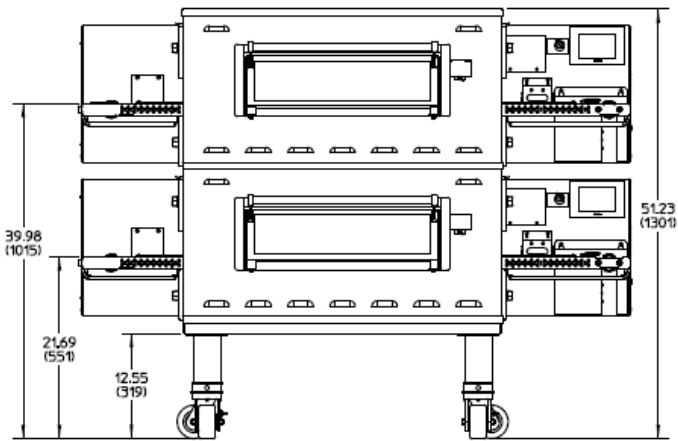

FRONT VIEW

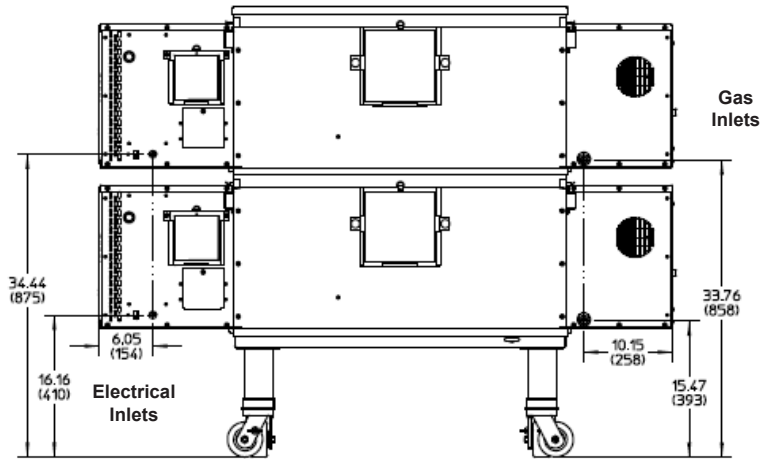

BACK VIEW

PS638-3

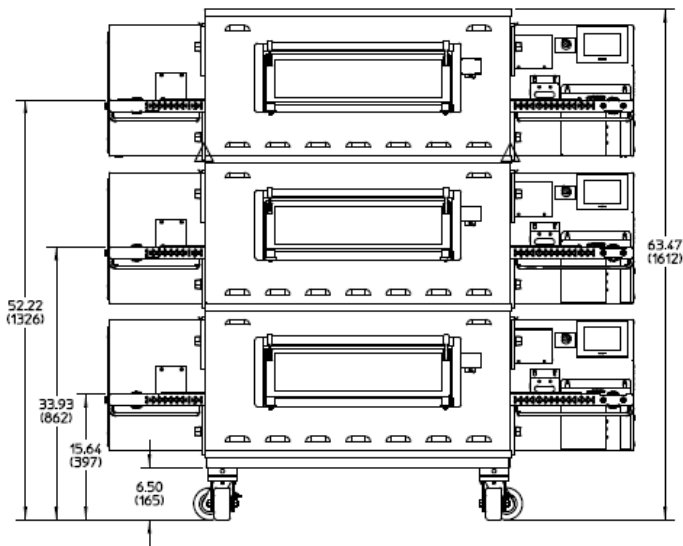

FRONT VIEW

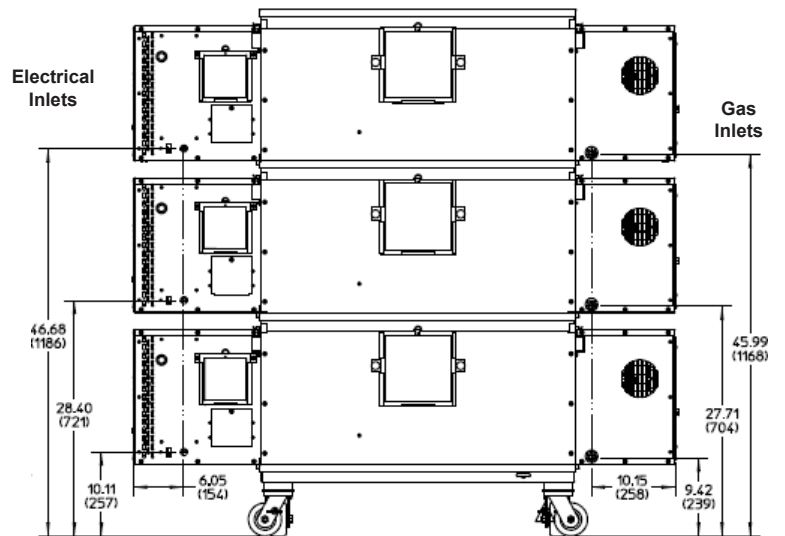

BACK VIEW

RECOMMENDED MINIMUM CLEARANCES

Rear of Oven to Wall	Control end of conveyor to wall	Non-control end of conveyor to wall
0"	0"	0"

GENERAL SPECIFICATIONS

	Heating Zone	Baking Area	Belt Length	Belt Width	Length	Height	Depth	Maximum Operating Temp	Bake Time Range	Ship Wt	Ship Cube
PS638-1	38" 969mm	7.1sq.ft. ² 0.66m ²	65-1/4" 1656mm	25" (635mm) or 2x12" (305mm)	65-1/4" 1656mm	42" 1064mm	50" 1270mm	600°F 315°C	2:00 - 30:00	820lbs. 372kg	115ft ³ 3.24m ³
PS638-2	76" 1938mm	14.2sq.ft. ² .1.32m ²	65-1/4" 1656mm	25" (635mm) or 2x12" (305mm)	65-1/4" 1656mm	51-1/4" 1301mm	50" 1270mm	600°F 315°C	2:00 - 30:00	1,640lbs. 744kg	230ft ³ 6.5m ³
PS638-3	114" 2907mm	21.3sq.ft. ² 1.98m ²	65-1/4" 1656mm	25" (635mm) or 2x12" (305mm)	65-1/4" 1656mm	63-1/2" 1612mm	50" 1270mm	600°F 315°C	2:00 - 30:00	2,460 lbs. 1116kg	345ft ³ 9.8m ³

ELECTRICAL SPECIFICATIONS

Version	Voltage	Phase	Freq	Current Draw	Supply	Breakers
USA & std export	208-240v	1	50/60Hz	4.5 Amp-Run 10 Amp-Start	3 wire (2 hot, 1 ground)	As per local codes
Europe (CE)	220-230v	1	50/60Hz	4.5 Amp-Run 10 Amp-Start	3 wire (2 hot, 1 ground)	As per local codes

* The current draw rating shown above are maximum values for normal operation, amperage draw will be less than the listed value.
NOTE: Each oven includes a 6' cord with NEMA# L6-20P plug. Customer to provide NEMA# L6-20R receptacle

GAS SUPPLY SPECIFICATIONS

Version	Gas Type	Supply (inlet) Pressure	Regulated Pressure	Rated Heat Input
Domestic & std export	Natural Gas	6-8" W.C. (14.9-19.9mbar) *	3.5" W.C. (8.7mbar)	89,000 BTU (26.1 kW)
Domestic & std export	Propane Gas	11-14"W.C. (27.4-34.9mbar) *	6" W.C. (14.9mbar)	89,000 BTU (26.1 kW)

* The required gas supply pressures of other locations are dependent on the local gas type and on all applicable local codes.

Minimum Gas Pipe Sizes:

* Natural Gas - 1 1/2" (50.8 mm) main supply line. One 3/4" (19mm) NP branch per oven cavity with individual full-flow shutoff valve.

* Propane Gas - 1 1/2" (31.8 mm) main supply line. One 3/4" (19mm) NP branch per oven cavity with individual full-flow shutoff valve

NOTE: Each oven includes (1) 3/4"(19mm)NPT x 48"(1219mm) flexible, vinyl coated stainless steel braided gas hose.

ALL SPECIFICATIONS SUBJECT TO CHANGE WITHOUT NOTICE.