



# REFRIGERATION

SERVING THE FOOD INDUSTRY SINCE 1951

## 47-INCH UNDER COUNTER FREEZER

Item: 50055 Model: FR-CN-1219-HC

*The perfect solution to add cold storage space for frozen products and ingredients conveniently within reach*



### FEATURES

- Stainless steel interior and exterior
- Refrigeration system keeps food at safe temperatures between -8°F and 0°F / -22°C to -18°C
- Self-closing doors with 90 degree stay-open feature
- Adjustable heavy-duty PVC coated shelves
- Digital control system makes it easy to adjust temperature set point and defrost frequency
- This unit uses HYDRO-CARBON R290 refrigerant, which is environmentally friendly and more efficient



### WARRANTY

2 YEARS PARTS & LABOR  
5 YEARS ONLY ON COMPRESSOR

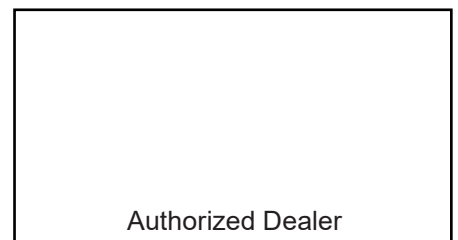
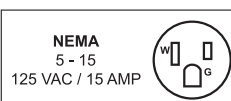

Authorized Dealer

# REFRIGERATION

47-INCH UNDER COUNTER FREEZER *FR-CN-1219-HC*



## TECHNICAL DRAWINGS AND DIMENSIONS

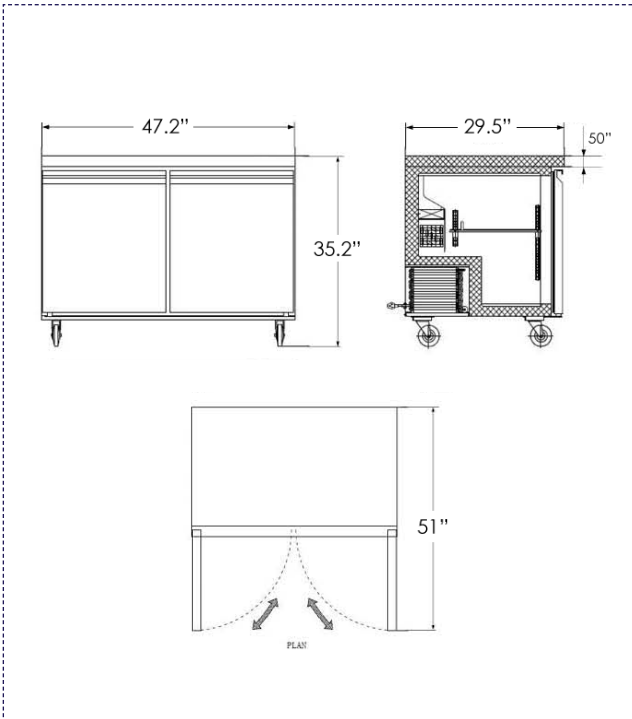

## PRODUCT SPECIFICATIONS

ITEM NUMBER	<b>50055</b>
MODEL	FR-CN-1219-HC
DESCRIPTION	47-inch Undercounter Freezer
TEMPERATURE RANGE	-8°F - 0°F / -22°C - -18°C
POWER	1/4+ HP
REFRIGERANT	R290
ISOLATION MATERIAL	Cyclopentane
COOLING SYSTEM	Ventilated
DEFROSTING	Automatic
TYPE OF CONTROLLER	Digital
SELF-CLOSING DOORS	Yes
AMPS	4.5
NUMBER OF DOORS	2
NUMBER OF SHELVES	2
SHELF MATERIAL	Coated steel
SHELF LOADING (KG/PC)	18 kg. / 39.6 lbs.
ELECTRICAL	115V / 60Hz / 1Ph
INTERIOR DIMENSIONS (WDH)	42.5" x 22.8" x 23.5" 1080 x 580 x 597 mm
OVERALL DIMENSIONS (WDH)	47.2" x 29.5" x 35.2" 1200 x 750 x 895 mm
PACKAGING DIMENSIONS	50 3/8" x 32 5/8" x 38 5/8" 1280 x 830 x 980 mm
NET VOLUME (CU. FT.)	12 cu. ft. / 338 L
WEIGHT	114 kg. / 251 lbs.
PACKAGING WEIGHT	142 kg. / 312 lbs.



## OMCAN INC.

Telephone: 1-800-465-0234  
 Fax: (905) 607-0234  
 Email: sales@omcan.com  
 Website: www.omcan.com



Follow us to keep up to date with the latest news and offers

