



COOKING EQUIPMENT

SERVING THE FOOD INDUSTRY SINCE 1951

24-INCH COMMERCIAL OVEN NATURAL GAS RANGE

Item: 46024 Model: CE-CN-0609-R



Features

- Stainless steel front and galvanized sides
- Cast iron open burner, each 30,000 BTU/hr
- Thermostat 250°F - 550°F controlled
- Welded frame structure for best stability
- Adjustable heavy-duty legs
- U-shape oven burner with 31,000 BTU/hr
- Pull-out crumb tray with angled handle at the front
- Anti-clogging pilot cover under the grate
- 12" x 12" cast iron grate



WARRANTY

PARTS AND LABOR



SHIPPED ON PALLET



Authorized Dealer

COOKING EQUIPMENT

24-INCH COMMERCIAL OVEN NATURAL GAS RANGE



TECHNICAL SPECIFICATIONS

ITEM NUMBER	46024
MODEL	CE-CN-0609-R
OVEN DIMENSIONS	20.5" x 25.8" x 13.9" / 520.7 x 655.32 x 353.06 mm
NUMBER OF BURNERS	4 top burner + 1 oven burner
POWER	4 x 30,000 BTU + 31,000 BTU
TOTAL INPUT BTU PER HR	151,000 BTU
OVEN TEMPERATURE	121°C - 288°C / 250°F - 550°F
DIMENSIONS (WDH)	24" x 32.6" x 59.8" / 609 x 827 x 1520 mm
GROSS DIMENSIONS	28.34" x 40.15" x 43.3" / 720 x 1020 x 1100 mm
WEIGHT	291.01 lbs. / 132 kg.
GROSS WEIGHT	357.14 lbs. / 162 kg.

TECHNICAL DRAWINGS AND DIMENSIONS

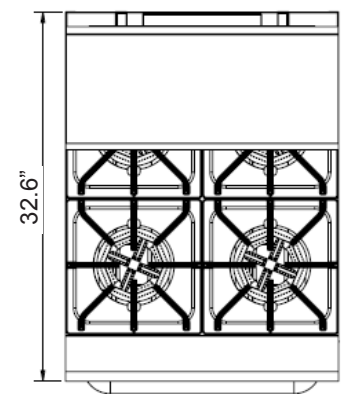
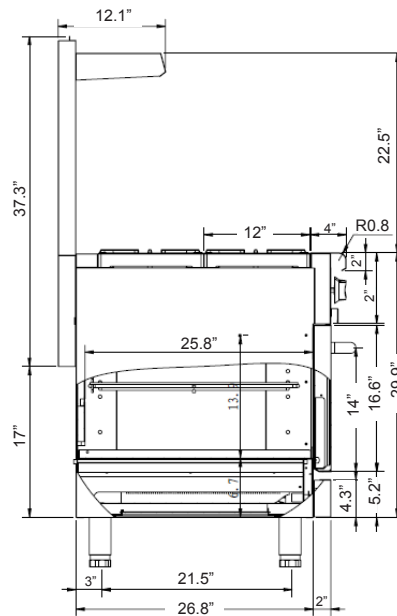
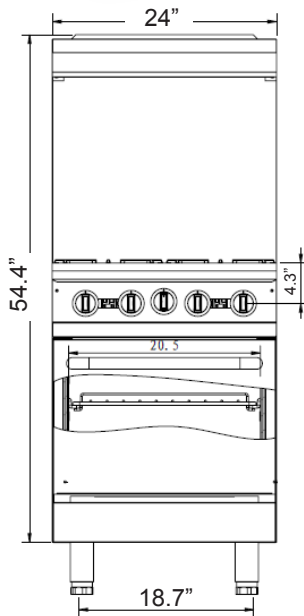

OMCAN INC.

Telephone: 1-800-465-0234
 Fax: (905) 607-0234
 Email: sales@omcan.com
 Website: www.omcan.com



Follow us to keep up to date with the latest news and offers





COOKING EQUIPMENT

SERVING THE FOOD INDUSTRY SINCE 1951

24-INCH COMMERCIAL GAS RANGE - LIQUID PROPANE

Item: 46124 Model: CE-CN-0609-L



Features

- Stainless steel front and galvanized sides
- Cast iron open burner, each 30,000 BTU/hr
- Thermostat 250°F - 550°F controlled
- Welded frame structure for best stability
- Adjustable heavy-duty legs
- U-shape oven burner with 31,000 BTU/hr
- Pull-out crumb tray with angled handle at the front
- Anti-clogging pilot cover under the grate
- 12" x 12" cast iron grate



WARRANTY

PARTS AND LABOR



SHIPPED ON PALLET



Authorized Dealer

COOKING EQUIPMENT

24-INCH COMMERCIAL GAS RANGE - LIQUID PROPANE



TECHNICAL SPECIFICATIONS

ITEM NUMBER	46124
MODEL	CE-CN-0609-L
OVEN DIMENSIONS	20.5" x 25.8" x 13.9" / 520.7 x 655.32 x 353.06 mm
NUMBER OF BURNERS	4 top burner + 1 oven burner
POWER	4 x 30,000 BTU + 31,000 BTU
TOTAL INPUT BTU PER HR	151,000 BTU
OVEN TEMPERATURE	121°C - 288°C / 250°F - 550°F
DIMENSIONS (WDH)	24" x 32.6" x 59.8" / 609 x 827 x 1520 mm
GROSS DIMENSIONS	28.34" x 40.15" x 43.3" / 720 x 1020 x 1100 mm
WEIGHT	291.01 lbs. / 132 kg.
GROSS WEIGHT	357.14 lbs. / 162 kg.

TECHNICAL DRAWINGS AND DIMENSIONS

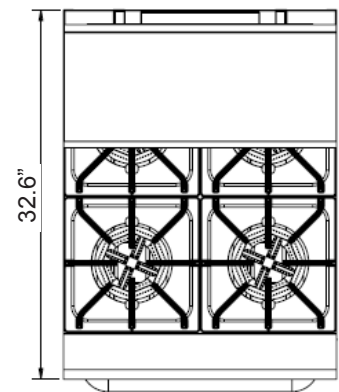
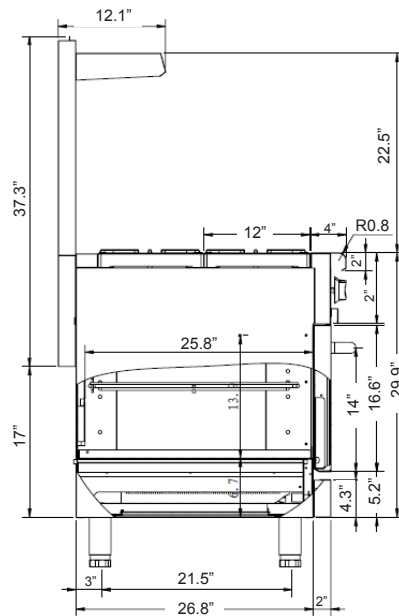
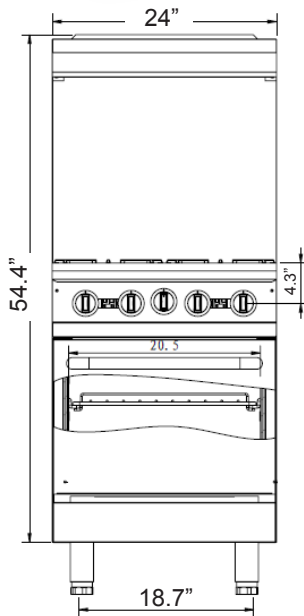

OMCAN INC.

Telephone: 1-800-465-0234
 Fax: (905) 607-0234
 Email: sales@omcan.com
 Website: www.omcan.com



Follow us to keep up to date with the latest news and offers

