

NOM-40-HT

GRAB 'N GO HEATED OPEN MERCHANDISERS

Ideal for restaurants, cafés, convenience stores and supermarkets



FEATURES



Standard pull-down night curtain



Black-brushed stainless steel exterior

Temperature of each shelf is independently controlled

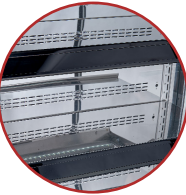

Price tag channels

Digital temperature control & light switches



Warm LED lighting on the top of unit and under each shelf

4 heavy duty casters and 2 front legs

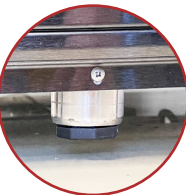

SPECIFICATIONS

Capacity (Cubic Feet)	13.7	
Capacity (Litres)	388	
Exterior Unit Dimensions (in)	39.5" (w) x 29" (d) x 78.75" (h)	
Interior Dimensions (in)	36" (w) x 22.5" (d) x 49" (h)	
Net/Gross Weight (lb)	425 / 606	
Night Curtain	Yes	
Swivel Casters	4 casters	
Front Support Legs	2	
Shelves	3 + base	
Shelf Dimensions (in)	33.25" (w) x 15" (d) / per shelf + base 35.75" (w) x 18.5" (d)	
Shelf Capacity (lb)	80	
Temperature	65-71°C	
Voltage (V)	208/60Hz/1PH	240/60Hz/1PH
Input Power (Watts)	3500	4800
Amperage (A)	17.12	20
Plug Type	Plug not supplied (power cord only)	

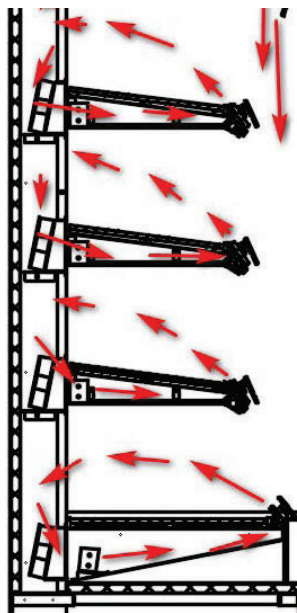

AIR CIRCULATION:
Hot air circulates around each shelf surface keeping products warm. These units are designed to hold pre-cooked foods at 65°C to 71°C (149°F to 160°F)

SIDE & INTERIOR VIEW

FRONT VIEW

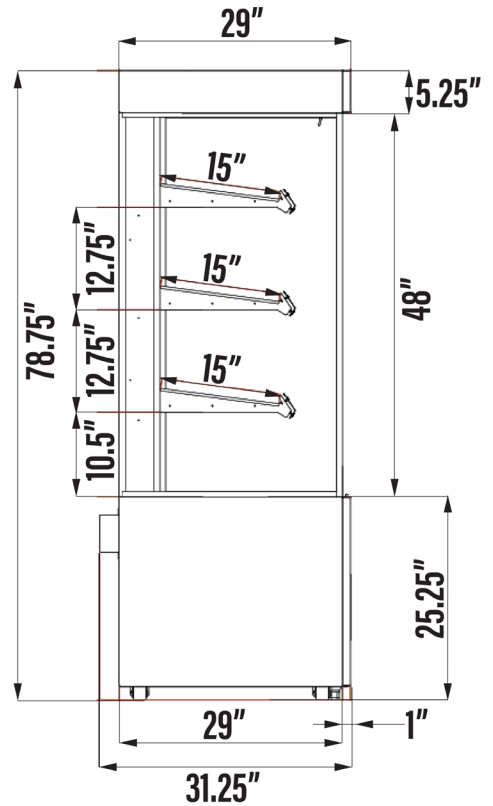
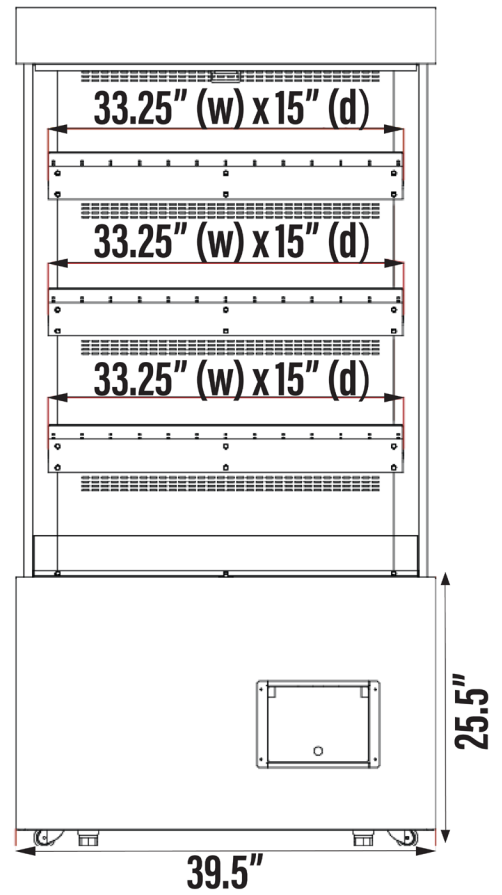

CUSTOMER SUPPORT



We're on social media!
1.800.567.3620



www.newairrefrigeration.ca

MORE PRODUCTS!



Design and specifications can change without prior notice for product improvement