



**MX50**

**HEAVY-DUTY MEAT MIXERS**

- Machine conforms to CE requirements
- Manufactured from AISI 304 stainless steel
- Transparent tank cover
- The tank can be tilted 90° for easy unloading
- Push button for temporary reverse rotation

**SPECIFICATIONS**

<b>Model</b>	<b>MX50</b>
<b>Horsepower</b>	1.5
<b>Working Capacity</b>	110.2 lbs.
<b>Electrical</b>	220V/60/1
<b>Weight</b>	165 lbs.
<b>Packaging Weight</b>	185 lbs.
<b>Dimensions (DWH)</b>	31.5" x 18" x 42"
<b>Packaging Dimensions</b>	40" x 24" x 50"
<b>Item #</b>	13159

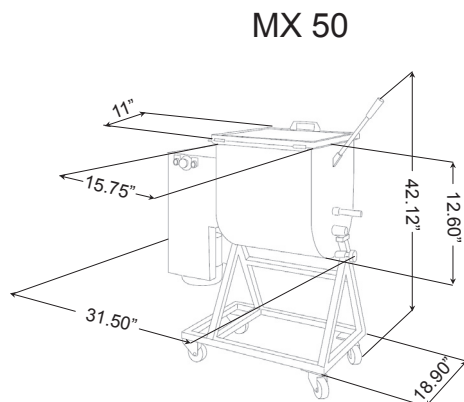

Mississauga, Ontario, Canada

Niagara Falls, New York, USA

Tel: (905) 828-0234 Toll-Free: 1-800-465-0234 Fax: (905) 607-0234 Email: sales@omcan.com

[www.omcan.com](http://www.omcan.com)